



user manual

Instrukcja obsługi | Руководство пользователя
Manuel de l'Utilisateur | Betriebsanweisung
Bruksanvisning | Manual del Usuario
Betjeningsvejledning | Gebruikershandleiding
Käyttöohjeet | Manual de utilizare | Bruksanvisning
Manuale d'uso | Příručka uživatele

Retain for future use
Zachować do przyszłego użytku
Сохраните для последующего
использования
A conserver pour une utilisation future
Für zukünftige Benutzung aufbewahren
Behold for senere bruk
Säilytä nämä käyttöohjeet tulevaa tarvetta marten
Opbevar manualen til fremtidig brug
Bewaren voor gebruik in de toekomst
Conservare il presente manuale a l'uso futuro
Păstrați acest manual pentru utilizare viitoare
Conservar para futuras consultas
Behall för framtida användning
Uchovejte pro další použití

Wood-Mizer[®] Sawmill

Safety, Setup, Operation & Maintenance Manual

LT70L DH

rev. A8.03



Safety is our #1 concern! Read and understand all safety information and instructions before operating, setting up or maintaining this machine.

June 2002

Form #1041

Table of Contents

Section-Page

SECTION 1	SAFETY	1-1
1.1	Safety Symbols.....	1-1
1.2	Safety Instructions.....	1-2
SECTION 2	SERVICING THE SAWMILL	2-1
2.1	If You Need To Order Parts	2-1
2.2	Customer and Sawmill Identification.....	2-2
2.3	If You Need Service	2-3
SECTION 3	SAWMILL SETUP	3-1
3.1	Sawmill Setup.....	3-1
3.2	Stationary Sawmill Setup	3-2
3.3	Portable Sawmill Setup	3-3
3.4	Middle Track Cover	3-6
3.5	Replacing The Blade	3-7
3.6	Tensioning The Blade.....	3-8
3.7	Tracking The Blade	3-9
3.8	Starting The Engine (or Motor).....	3-11
SECTION 4	SAWMILL OPERATION	4-1
4.1	Hydraulic Control Operation.....	4-1
4.2	Loading, Turning And Clamping Logs	4-3
4.3	Up/Down Operation	4-5
4.4	Blade Guide Arm Operation.....	4-6
4.5	Power Feed Operation	4-7
4.6	Cutting The Log	4-9
4.7	Edging.....	4-10
4.8	Optional Cutting Procedure.....	4-11
4.9	Blade Height Scale	4-11
4.10	Water Lube Operation.....	4-13
4.11	Preparing The Sawmill For Towing.....	4-14
SECTION 5	MAINTENANCE	5-1
5.1	Wear Life.....	5-1
5.2	Blade Guides	5-2
5.3	Sawdust Removal.....	5-4
5.4	Carriage Track, Wiper & Scrapers	5-4
5.5	Vertical Mast Rails.....	5-6
5.6	Drum Switches	5-6
5.7	Miscellaneous	5-6
5.8	Brake Adjustment.....	5-7
5.9	Drive Belt Adjustment.....	5-9
5.10	Up/Down System.....	5-10
5.11	Charging The Battery (DC Only).....	5-12
5.12	Hydraulic System	5-13
5.13	Power Feed	5-15

Table of Contents

Section-Page

SECTION 6	TROUBLESHOOTING GUIDE	6-1
6.1	Sawing Problems.....	6-1
6.2	Electrical Problems.....	6-3
6.3	Power Feed Problems.....	6-5
6.4	Power Feed Circuit Troubleshooting.....	6-7
6.5	Hydraulic Problems.....	6-10
6.6	Engine/Motor and Drive Pulleys Alignment.....	6-15
6.7	Power Feed Variable Feed Rate Switch Test.....	6-15
6.8	Power Feed Preliminary Test.....	6-15
6.9	Power Feed Mechanical Test.....	6-15
6.10	Fuse Terminal Extension Stud.....	6-17
6.11	Circuit Breaker Operation.....	6-19
SECTION 7	SAWMILL ALIGNMENT	7-1
7.1	Routine Alignment Procedure.....	7-1
7.2	Horizontal Adjustment of Side Supports.....	7-13
7.3	Vertical Adjustment of Side Supports.....	7-14
7.4	Complete Alignment Procedure.....	7-16
SECTION 8	SPECIFICATIONS	8-1
8.1	Log Capacity.....	8-1
8.2	Overall Dimensions.....	8-1
8.3	Engine/Motor Specifications.....	8-2
8.4	Chains.....	8-3
8.5	Hydraulic System.....	8-3
8.6	Belt Sizes.....	8-3
8.7	Hydraulic Blade Tensioner Schematic.....	8-4
8.8	Hydraulic Blade Tensioner Components.....	8-5
8.9	Sawdust Extractor Specifications.....	8-5
SECTION 9	HYDRAULIC INFORMATION	9-1
9.1	LT70LDH Hydraulic Schematic.....	9-1
9.2	LT70LDH Hydraulic Hoses.....	9-2

SECTION 1 SAFETY

1.1 Safety Symbols

The following symbols and signal words call your attention to instructions concerning your personal safety. Be sure to observe and follow these instructions.



DANGER! indicates an imminently hazardous situation which, if not avoided, will result in death or serious injury.



WARNING! suggests a potentially hazardous situation which, if not avoided, could result in death or serious injury.



CAUTION! refers to potentially hazardous situations which, if not avoided, may result in minor or moderate injury or damage to equipment.



IMPORTANT! indicates vital information.

NOTE: gives helpful information.



Warning stripes are placed on areas where a single decal would be insufficient. To avoid serious injury, keep out of the path of any equipment marked with warning stripes.

1.2 Safety Instructions

NOTE: ONLY safety instructions regarding personal injury are listed in this section. Caution statements regarding only equipment damage appear where applicable throughout the manual.

OBSERVE SAFETY INSTRUCTIONS



IMPORTANT! Read the entire Operator's Manual before operating the sawmill. Take notice of all safety warnings throughout this manual and those posted on the machine. Keep this manual with this machine at all times, regardless of ownership.

Also read any additional manufacturer's manuals and observe any applicable safety instructions including dangers, warnings, and cautions.

Only persons who have read and understood the entire operator's manual should operate the sawmill. The sawmill is not intended for use by or around children.

IMPORTANT! It is always the owner's responsibility to comply with all applicable federal, state and local laws, rules and regulations regarding the ownership, operation and towing of your Wood-Mizer sawmill. All Wood-Mizer mill owners are encouraged to become thoroughly familiar with these applicable laws and comply with them fully while using or towing the mill.



WEAR SAFETY CLOTHING

WARNING! Secure all loose clothing and jewelry before operating the sawmill. Failure to do so may result in serious injury or death.

WARNING! Always wear gloves and eye protection when handling bandsaw blades. Changing blades is safest when done by one person! Keep all other persons away from area when coiling, carrying or changing a blade. Failure to do so may result in serious injury.

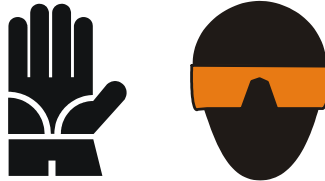

WARNING! Always wear eye, ear, respiration, safety clothing, and foot protection when operating or servicing the sawmill.

**KEEP SAWMILL AND AREA AROUND SAWMILL CLEAN**

DANGER! Maintain a clean and clear path for all necessary movement around the mill and lumber stacking areas. Failure to do so will result in serious injury.

HANDLE FUEL/LUBRICANTS SAFELY



DANGER! Due to the flammable nature of fuel and oil, never smoke, weld, grind or allow sparks near your engine or storage tanks, especially during times of fueling.

DANGER! Never allow fuel to spill on a hot engine during fueling operations or otherwise. The hot temperature of your engine could induce a fire or explosion.



WARNING! Store gasoline away from sawdust and other flammable materials. Failure to do so may result in serious injury.



WARNING! Use ONLY water with the water lube accessory. Never use flammable fuels or liquids. If these types of liquids are necessary to clean the blade, remove it and clean with a rag. Failure to do so may result in serious injury or death.

WARNING! Drum switch grease contains Petroleum Hydrocarbon Lubricant. Eye and skin irritant. If introduced into eyes, flush with water for at least 15 minutes. If film or irritation persists, seek medical attention. Wash skin with soap and water. If ingested, do not induce vomiting - contact a physician. KEEP OUT OF THE REACH OF CHILDREN.

CAUTION! The sawmill's work-stand should be equipped with a 4 kg or bigger dry powder extinguisher.

DISPOSE OF SAWING BY-PRODUCTS PROPERLY



IMPORTANT! Always properly dispose of all sawing by-products, including sawdust and other debris, coolant, oil, fuel, oil filters and fuel filters.

USE CAUTION WHEN WORKING WITH BATTERIES (GAS & DIESEL SAWMILLS ONLY)

DANGER! Batteries expel explosive gases. Keep sparks, flames, burning cigarettes, or other ignition sources away at all times. Always wear safety goggles and a face shield when working near batteries. Failure to do so will cause serious injury.¹



WARNING! Battery posts, terminals and related accessories contain lead and lead compounds, chemicals known to the State of California to cause cancer and reproductive harm. Wash hands after handling.



WARNING! Charge the battery in a well ventilated area. Do not attempt to charge a frozen battery.

Use extreme care to avoid spilling or splashing electrolyte (which is dilute sulfuric acid) as it can destroy clothing and burn the skin. If electrolyte is spilled or splashed on clothing or the body, it should be neutralized immediately and then rinsed with clean water. A solution of baking soda, or household ammonia, and water may be used as a neutralizer.

Electrolyte splashed into the eyes is extremely dangerous. If this should happen, force the eye open and flood it with cool, clean water for approximately fifteen minutes. A doctor should be called immediately when the accident occurs and “on-the-spot” medical attention given if possible. If a doctor cannot come to the scene of the accident immediately, follow his instructions concerning actions to take. Do not add eye drops or other medication unless advised to do so by the doctor. Do not place a battery or acid within the reach of children. If acid (electrolyte) is taken internally drink large quantities of water or milk. Follow with milk of magnesia, beaten egg or vegetable oil. Call a physician immediately.

If electrolyte is spilled or splashed on any surface of the machine, it should be neutralized and rinsed with clean water.



CAUTION! Do not overcharge the battery. Overcharging may reduce the overall service life of the battery.

CAUTION! Be sure the battery is fully charged before transporting the sawmill. If the battery is not fully charged, excessive vibration could reduce the overall service life of the battery.

¹Battery Council International, copyright 1987

CAUTIONS FOR SAWMILL SETUP



WARNING! Do not set up the mill on ground with more than a 10 degree incline. If setup on an incline is necessary, put blocks under one side of the mill or dig out areas for the outrigger legs to keep mill level. Setting up the mill on an incline could cause it to tip over, resulting in serious personal injury.

WARNING! Chock the trailer wheels to prevent movement before unhitching it from the towing vehicle. Failure to do so may result in serious injury or death.

WARNING! Put front outrigger down before moving saw head from the rest position. Failure to do so may result in serious injury.

WARNING! Always make sure the trailer is supporting the sawmill frame when operating a sawmill with adjustable outriggers. Failure to do so may result in serious injury or death. The adjustable outriggers are intended to support the saw frame with assistance from the trailer.

WARNING! Securely fasten the feet of a stationary sawmill to the floor before operating the sawmill. Failure to do so may result in serious injury or death.

CHECK SAWMILL BEFORE OPERATION



DANGER! Make sure all guards and covers are in place and secured before operating or towing the sawmill. Failure to do so may result in serious injury.

Be sure the blade housing and pulley covers are closed (i.e. the safety switches located on them are engaged).



KEEP PERSONS AWAY



DANGER! Stay clear of the area between the trailer axle and saw carriage. Failure to do so will result in serious injury.



DANGER! Keep all persons out of the path of moving equipment and logs

when operating sawmill or loading and turning logs. Failure to do so will result in serious injury.

DANGER! Always be sure that all persons are out of the path of the blade before starting the engine or motor. Failure to do so will result in serious injury.

KEEP HANDS AWAY



DANGER! Always shut off the sawmill engine before changing the blade. Failure to do so will result in serious injury.

DANGER! Engine components can become very hot during operation. Avoid contact with any part of a hot engine. The exhaust components of your engine are especially hot during and following operation. Contact with hot engine components can cause serious burns. Therefore, never touch or perform service functions on a hot engine. Allow the engine to cool sufficiently before beginning any service function.

DANGER! Always keep hands away from moving bandsaw blade. Failure to do so will result in serious injury.

DANGER! Always be aware of and take proper protective measures against rotating shafts, pulleys, fans, etc. Always stay a safe distance from rotating members and make sure that loose clothing or long hair does not engage rotating members resulting in possible injury.



WARNING! Do not for any reason adjust the engine drive belts or belt support bracket with the engine running. Doing so may result in serious injury.

CAUTIONS FOR GAS OR DIESEL ENGINE OPERATION



DANGER! Operate your engine/machine only in well ventilated areas. The exhaust gases of your engine can cause nausea, delirium and potentially death unless adequate ventilation is present.

DANGER! Never operate an engine with a fuel or oil leak. The leaking fuel or oil could potentially come in contact with hot surfaces and ignite into flames.

WARNING! Do not operate engine without proper and operational spark arrester/muffler. Sparks emitted from the engine exhaust could ignite surrounding materials, causing serious injury or death.

USE PROPER PROCEDURE WHEN CONDUCTING ELECTRICAL SAFETY CHECKS AND MAINTENANCE



DANGER! Make sure all electrical installation, service and/or maintenance work is performed by a qualified electrician and is in accordance with applicable electrical codes.

DANGER! Hazardous voltage inside the electric boxes and at the motor can cause shock, burns, or death. Disconnect and lock out power supply before servicing! Keep all electrical component covers closed and securely fastened during mill operation.



WARNING! Consider all electrical circuits energized and dangerous.

WARNING! Never assume or take the word of another person that the power is off; check it out and lock it out.

WARNING! Do not wear rings, watches, or other jewelry while working around an open electrical circuit.

WARNING! Before performing service near moving parts such as blades, pulleys, motors, belts and chains, first turn the key switch to the OFF (#0) position and remove the key. If the key is turned on and moving parts activated, serious injury may result.

WARNING! Remove the blade before performing any service to the engine or

sawmill. Failure to do so may result in serious injury.

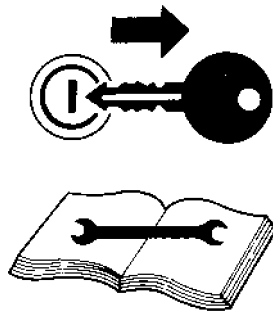

KEEP SAFETY LABELS IN GOOD CONDITION



IMPORTANT! Always be sure that all safety decals are clean and readable. Replace all damaged safety decals to prevent personal injury or damage to the equipment. Contact your local distributor, or call your Customer Service Representative to order more decals.



IMPORTANT! If replacing a component which has a safety decal affixed to it, make sure the new component also has the safety decal affixed.

USE CAUTION WHEN WORKING WITH HEAVY LOGS



WARNING! Always make sure log is clamped securely before sawing. Failure to do so may result in serious injury or death.

AUTOMATIC BOARD RETURN SAFETY



DANGER! Keep all persons out of the path of returning boards. Failure to do so will result in serious injury.



WARNING! The automatic board return is intended to assist a second operator in removing boards quickly. Do not use the board return when operating the sawmill alone. Serious injury, death or damage to the equipment may result.

WARNING! Never use the board return table as a platform to stand on. This table is designed and intended to assist in the removal of boards only. Standing on the table may result in serious injury.

POWER FEED SYSTEM SAFETY



DANGER! If leaving the blade engaged for maximum production rates, make sure the off-bearer stays out of the path of the blade. Failure to do so will result in serious injury or death.



WARNING! Be sure the power feed switch is in the neutral position before turning the key switch to the #1, #2 or #3 position. This prevents accidental carriage movement which may cause serious injury or death.

GENERAL TRAILER SAFETY



DANGER! Be sure that the hitch and the safety cable are secured before towing the sawmill. The safety cable automatically operates the trailer handbrake lever in case the hitch should become disengaged. Failure to do so may result in serious personal injury and/or severe machine damage.

DANGER! Make sure all light connections have been made and are working properly before towing the sawmill. Failure to do so may result in serious personal injury and/or severe machine damage.

See Table 1-1. Pictogram decals used to warn and inform the user about danger in the LT70.

TABLE 1-1



Decal View	W-M No.	Description
	096317	CAUTION! Read thoroughly the manual before operating the machine. Observe all safety instructions and rules when operating the sawmill.
	099220	CAUTION! Close all guards and covers before starting the machine.

TABLE 1-1

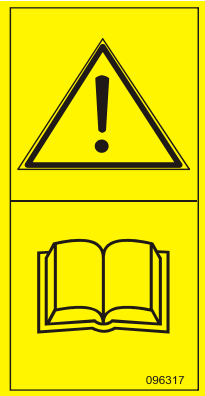

 <p>099221</p>	<p>099221</p>	<p>CAUTION! Keep all persons a safe distance away from work area when operating the machine.</p>
 <p>098176</p>	<p>098176</p>	<p>CAUTION! Keep away from debarker blade!</p>
 <p>096316</p>	<p>096316</p>	<p>CAUTION! Do not open or close the electric box when the switch is not in the "0" position.</p>
 <p>096319</p>	<p>096319</p>	<p>CAUTION! Disconnect power supply before opening the box.</p>

TABLE 1-1



 <p>085977B</p>	<p>085977B</p>	<p>No lift the machine grasping by the element!</p>
 <p>086099</p>	<p>086099</p>	<p>CAUTION! Keep away - hot parts!</p>
 <p>099222</p>	<p>099222</p>	<p>CAUTION! Sawdust outlet. Protect eyes!</p>
 <p>099542</p>	<p>099542</p>	<p>CAUTION! Trailer.</p>
 <p>096321</p>	<p>096321</p>	<p>Blade movement direction</p>

TABLE 1-1

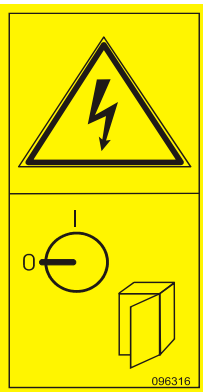
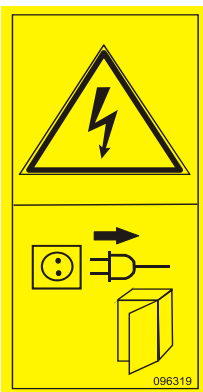

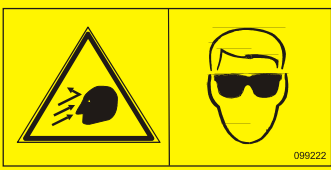
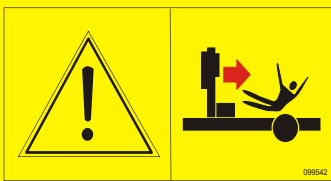
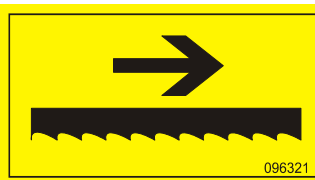

 <p>A blue circular icon with a white silhouette of a person wearing safety goggles. The text 'S12004G' is printed in the bottom right corner of the circle.</p>	<p>S12004G</p>	<p>CAUTION! Always wear safety goggles when operating the sawmill!</p>
 <p>A blue circular icon with a white silhouette of a person wearing protective ear muffs. The text 'S12005G' is printed in the bottom right corner of the circle.</p>	<p>S12005G</p>	<p>CAUTION! Always wear protective ear muffs when operating the sawmill!</p>
 <p>A diagram showing a saw blade with four arrows indicating alignment: two vertical arrows (up and down) and two circular arrows (clockwise and counter-clockwise). The text 'P11789/PL' is printed at the bottom.</p>	<p>P11789</p>	<p>Aligning the blade on the wheels</p>
 <p>The CE (Conformité Européenne) certification mark, consisting of the letters 'C' and 'E' in a stylized font.</p>	<p>P85070</p>	<p>CE safety certification</p>
 <p>The Russian certification mark, featuring the Cyrillic letters 'Р' and 'Г' inside a stylized 'G' shape, with 'АЯ04' below it. The text '099401' is printed in the bottom right corner.</p>	<p>099401</p>	<p>Russian safety certification</p>

TABLE 1-1

	S20097	Motor rotation direction
---	--------	--------------------------

SECTION 2 SERVICING THE SAWMILL

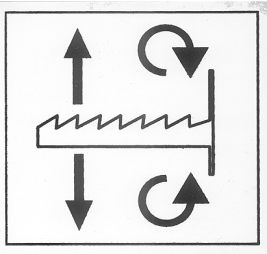
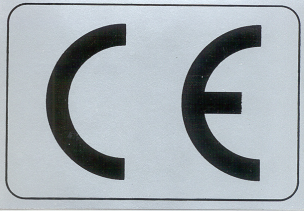
Wood-Mizer is committed to providing you with the latest technology, best quality and strongest customer service available on the market today. We continually evaluate our customers' needs to ensure we're meeting current wood-processing demands. Your comments and suggestions are welcome.

2.1 If You Need To Order Parts

From Europe call our European Headquarters and Manufacturing Facility in Kolo, Poland at **+48-63-2626000**. Please have the vehicle identification number and your customer number ready when you call. Wood-Mizer will accept these methods of payment:

- Visa, Mastercard, or Discover
- COD
- Prepayment
- Net 15 (with approved credit)

Be aware that shipping and handling charges may apply. Handling charges are based on size and quantity of order. In most cases, items will ship on the day they are ordered.

2.2 Customer and Sawmill Identification

Each Wood-Mizer sawmill has a model number and a 17-digit Vehicle Identification Number (VIN). In addition, when you pick up your mill, you will receive a customer number. These three numbers will help expedite our service to you. Please locate them now and write them below so you have quick, easy access to them. See the following figures for model number and V.I.N. descriptions and locations.

(To be filled in by purchaser)

Mill Model _____
 Mill VIN _____
 Customer No. _____

LT70

Basic Sawmill I.D.

E25

Engine/Motor Configuration

MODEL NUMBER DESCRIPTION

See below for a description of the V.I.N.

Company Identification Number 456=Wood-Mizer Indiana	Weight Class; A=Under 1300 kg B=1300 -1800kg C=1800-2200 kg D=2200kg-3000kg	Product No.: 1=LT15, 2=LT20, 4=LT40 Series, 7=LT70 Series	Length of the Trailer; 20=20 Ft., 24=24', 35=35'	Number of axles on the trailer	Check Digit Add all the numbers and divide by 11	Year of Manufacture; Y=2001, Z=2002, A=2003, B=2004, C=2005, D=2006	State of Manufacture N=Indiana, P=Poland	Month of Manufacture A=January, B=February, C=March, etc...	Revision Level	Sequence Number Ranging from 000-999	End of 17-Digit VIN	Revision Level (Repeated)	Two-Digit Minor Revision Level
456	A	7	24	1	X	S	N	A	F9	017		F9	.01

V.I.N. DESCRIPTION.

The model number and V.I.N. can be found in the following locations.



MODEL NUMBER AND V.I.N. LOCATIONS

2.3 If You Need Service

From Europe call our European Headquarters and Manufacturing Facility in Kolo, Poland at **+48-63-2626000**. From the continental U.S., call us toll-free at **1-800-525-8100**. Ask to speak with a Customer Service Representative. Please have your vehicle identification number and your customer number ready when you call. The Service Representative can help you with questions about alignment of your mill, blade sharpening, or cutting a particular species of wood. He also can schedule you for a service call.

Office Hours: All times are Eastern Standard Time. Please remember that Indiana does not go on Daylight Savings Time in the summer.

Country	Monday - Friday	Saturday	Sunday
U.S., Indiana	8 a.m. to 5 p.m.	8 a.m. to 4 p.m.	Closed
Poland	8 a.m. to 4:30 p.m.	8 a.m. to 1 p.m.	Closed

! **IMPORTANT!** Read the entire Operator's Manual before operating the sawmill. Take notice of all safety warnings throughout this manual and those posted on the machine. Keep this manual with this machine at all times, regardless of ownership.

SECTION 3 SAWMILL SETUP

3.1 Sawmill Setup



IMPORTANT! Before starting to use the sawmill you have to meet the following conditions:

- Set up the sawmill on firm and level ground.
- The sawmill can be operated with the sawdust collection system only.
- The sawmill can be operated under roof only.
- The sawmill can be operated in temperature range from 5° C to 40° C only.
- The sawmill operator's position is shown below.

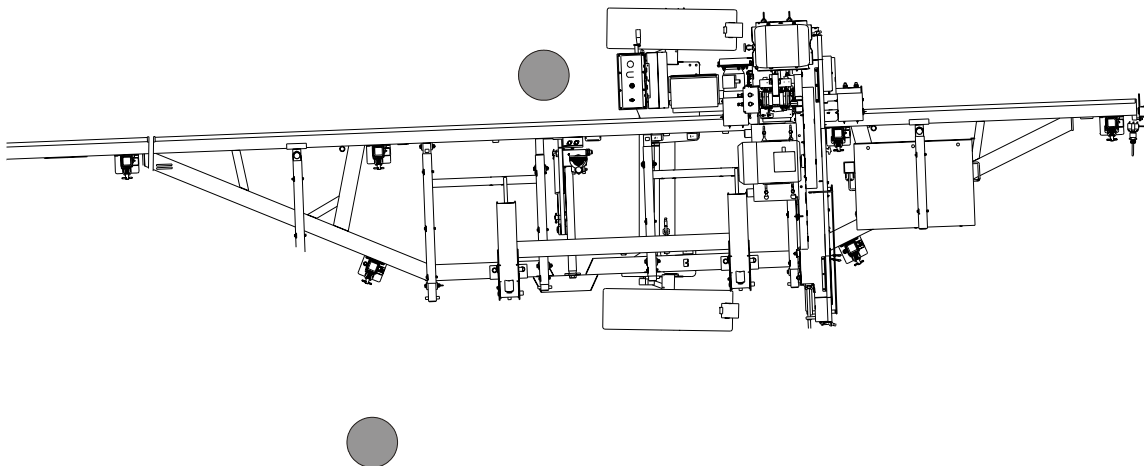

- Have a qualified electrician install the power supply (according to EN 60204 Standard). The power supply must meet the specifications given in the table below.

3-Phase Volts	Fuse disconnect	Suggested Wire Size
400 VAC	40 A	6 mm ² up to 15 m long

TABLE 3-0



IMPORTANT! When starting the machine for the first time, check that main motor rotation direction is as indicated by the arrow located on the motor body (fan guard). If the rotation direction is incorrect, invert the phases in the phase inverter in the power socket (electric box). Setting the phases in the phase inverter correctly will ensure correct rotation directions of all sawmill motors.

3.2 Stationary Sawmill Setup

Prepare a firm, level area where the sawmill can be anchored. There should be enough room around the sawmill for operators, sawdust removal, log loading and board removal. A cement pad with 5/8" (16 mm) diameter anchor bolts is recommended. The cement pad should be rated to support 6350 lbs./sq.ft. (31 T/m²) at each sawmill foot position.

NOTE: Make sure the unit is level before securing. It is possible to twist the mill frame by jacking one foot higher than the others.

 **WARNING!** Securely fasten the feet of a stationary sawmill to the floor before operating the sawmill. Failure to do so may result in serious injury or death.

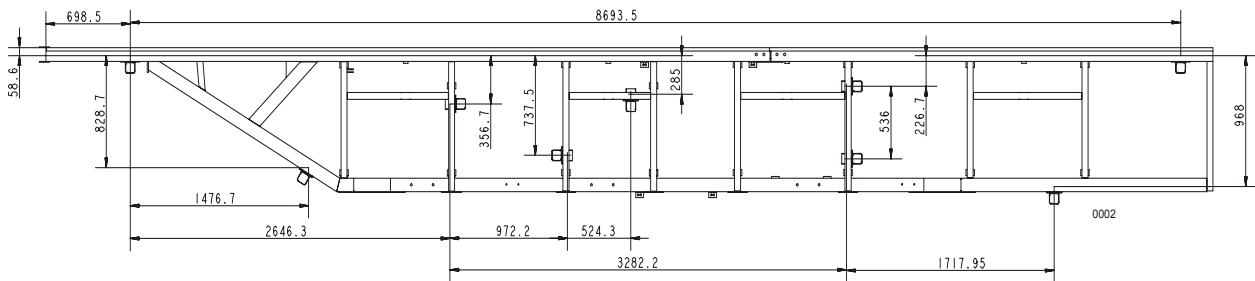

Stationary sawmill*

*all diameters in millimeters

1. Unhook the carriage safety chain, located at the bottom of the vertical mast.
2. Start the engine to enable the battery-operated accessories ([See Section 3.6](#)). Use the up/down switch on the control panel to raise the cutting head from the carriage rest pin. Remove the locking pin and swing the rest pin down below bed level.



 **CAUTION!** Always make sure the engine is running before operating the sawmill controls. Operating the controls without the engine running will result in power drainage from the battery.

3. Use the carriage forward/reverse switch (left side of control box) to move the cutting head toward the front end of the mill.



Raise the two side supports that will prevent a log from falling off the side of the mill when loaded.

See Figure 3-1.

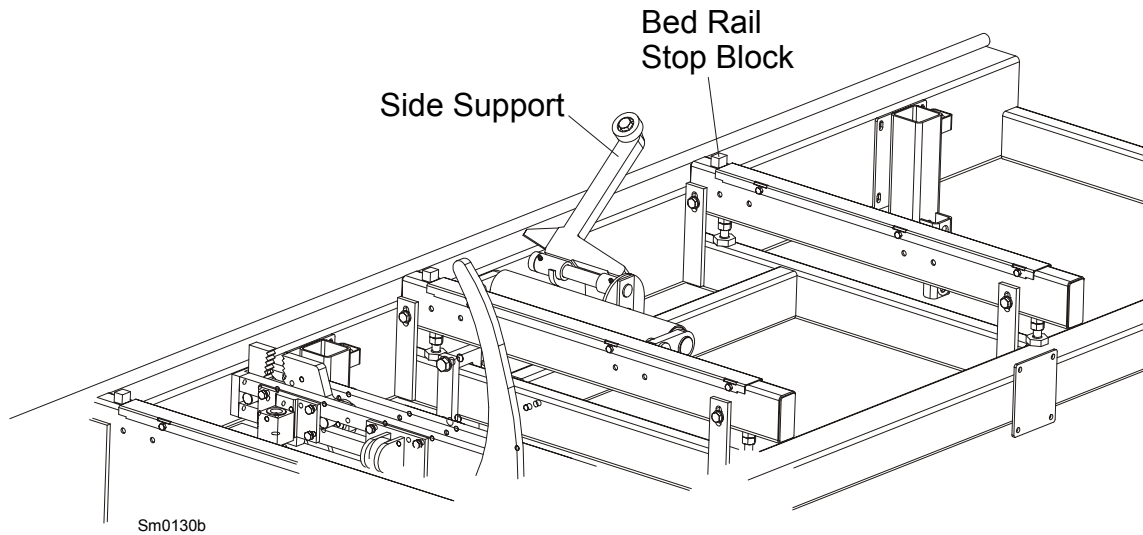

FIG. 3-1

3.3 Portable Sawmill Setup



WARNING! Do not set up the mill on ground with more than a 10 degree incline. If setup on an incline is necessary, put blocks under one side of the mill or dig out areas for outrigger legs to keep mill level. Setting up the mill on an incline could cause it to tip over, resulting in serious personal injury.

WARNING! Chock the trailer wheels to prevent movement before unhitching it from the towing vehicle. Failure to do so may result in serious injury or death.

WARNING! Always make sure the trailer is supporting the sawmill frame when operating a sawmill with adjustable outriggers. Failure to do so may result in serious injury or death. The adjustable outriggers are intended to support the saw frame with assistance from the trailer.

1. Unhitch the mill from the vehicle.
2. Lower and set the front outriggers. To lower the leg, pull the locking pin out of the outrigger hole. When the outrigger contacts the ground, release the pin. Place a 19 socket wrench on the outrigger adjustment bolt and turn the bolt until the locking pin enters the nearest outrigger hole.



WARNING! Put front outrigger down before moving cutting head from the rest position. Failure to do so may result in serious injury.

See Figure 3-2.

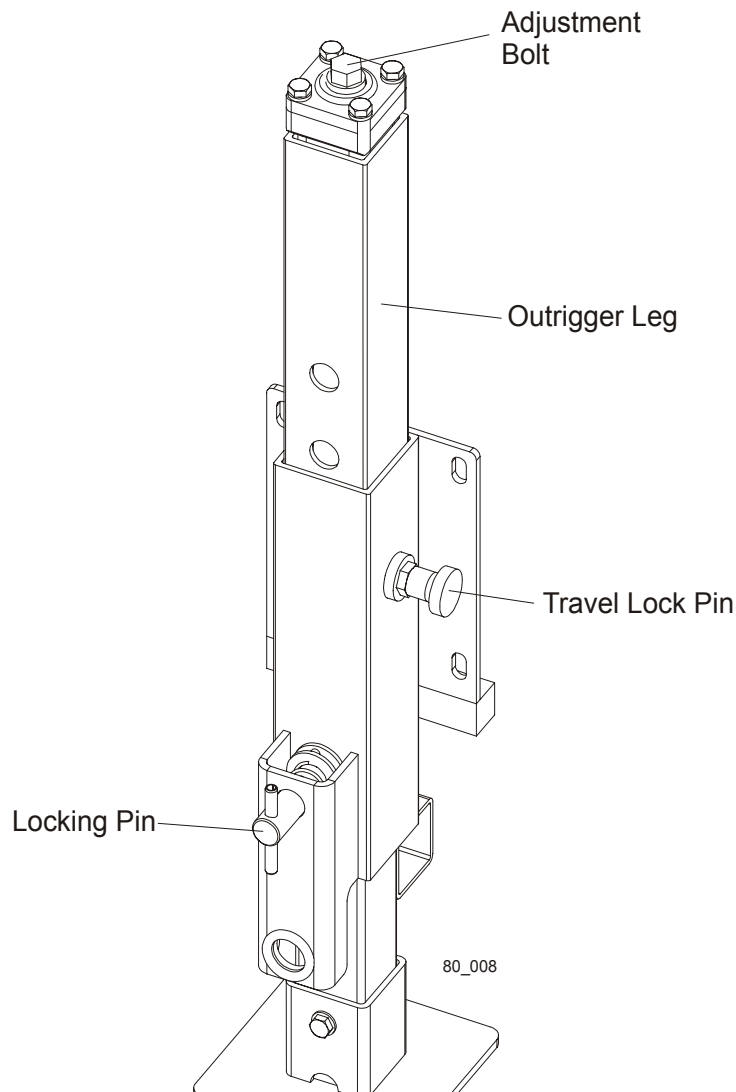

FIG. 3-2. OUTRIGGER ADJUSTMENT.



CAUTION! If setup sawmill on a boggy terrain (such as deep mud or sand) place the board or metal plate under each outrigger leg to prevent it from sinking.

1. Unhook the carriage safety chain, located at the bottom of the vertical mast.
2. Start the engine to enable the battery-operated accessories ([See Section 3.8](#)). Use the up/down switch on the control panel to raise the cutting head from the carriage rest pin. Remove the locking pin and swing the rest pin down below bed level.



CAUTION! Always make sure the engine is running before operating the sawmill controls. Operating the controls without the engine running will result in power drainage from the battery.

3. Remove the fenders by lifting them out of the slots.

CAUTION! To prevent fender damage, remove fenders before operating sawmill or loading logs.



4. Use the carriage forward/reverse switch (left side of control box) to move the cutting head toward the front end of the mill.



5. Lower and set the remaining rear outriggers. Level the sawmill by turning each outrigger adjustment bolt clockwise to raise a given sawmill end, or counterclockwise to lower it. Adjust all outriggers evenly to avoid twisting the mill frame by jacking one outrigger higher than the others.
6. Raise the side supports to prevent the log from falling off the side of the mill when loaded.

See Figure 3-3.

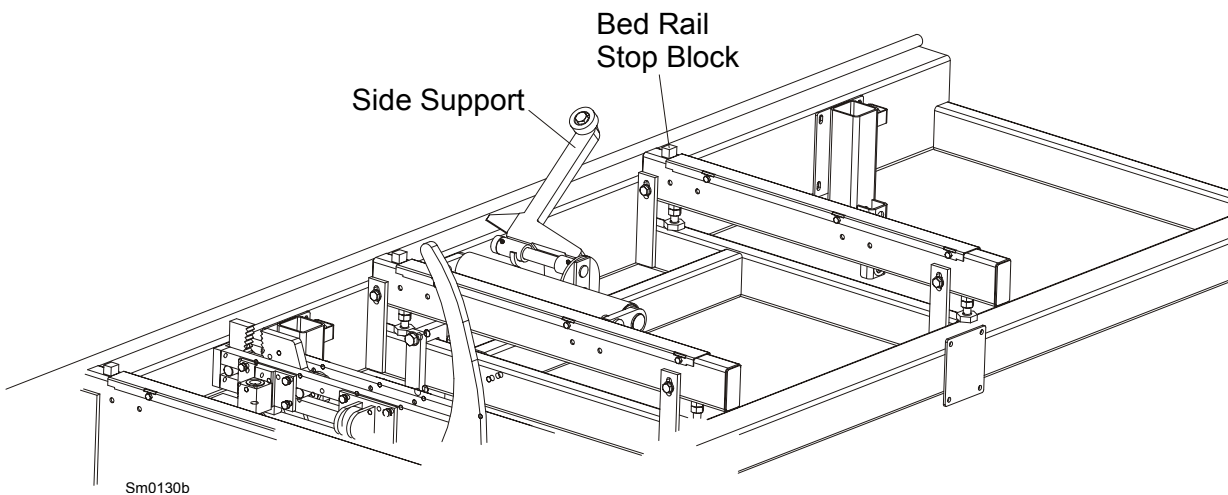

FIG. 3-3

3.4 Middle Track Cover

Before operating the sawmill do as follows:

1. Clean the upper and lower rails to remove any sawdust and rust preventives.
2. Unbolt and remove the middle track cover from its storage position.
3. Soak the felt wiper with Dexron III transmission fluid, 10W30 motor oil or 3-in-1 turbine oil.
4. Install the middle track cover so it fits against the rail and secure with two thumb screws.

See Figure 3-4.

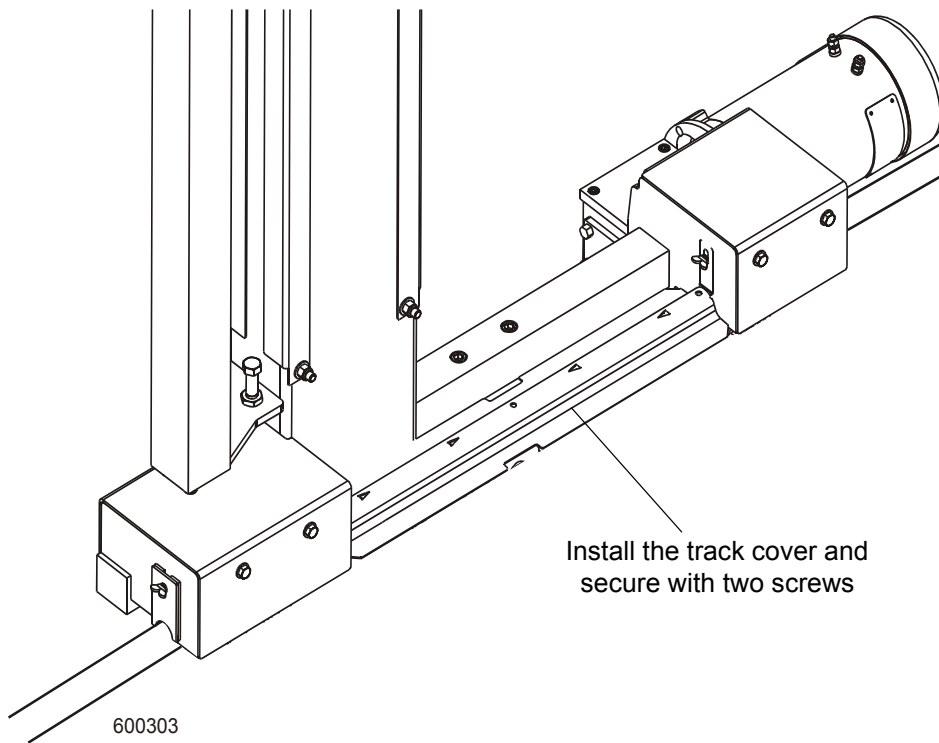



FIG. 3-4

 **CAUTION!** Install the track cover so that it lightly touches the track rail. If the wiper presses too firmly against the rail, it can cause the power feed to bind.

3.5 Replacing The Blade



DANGER! Always shut off the sawmill engine before changing the blade. Failure to do so will result in serious injury.



WARNING! Always wear gloves and eye protection when handling bandsaw blades. Changing blades is safest when done by one person! Keep all other persons away from area when coiling, carrying or changing a blade. Failure to do so may result in serious injury.

Adjust the blade guide arm all the way open.

Open the two blade housing covers that cover the blade wheels. Release the blade tension [See Section 3.6](#) until the wheel is pulled in and the blade is lying loose in the blade housing. Lift the blade out of the blade housing.

When installing a blade, make sure the teeth are pointing the correct direction. The teeth should be pointing toward the operator side of the mill when you are looking at the blade below the blade guides. Install the blade so it is lying around the wheels.



CAUTION! Be careful when placing the blade between the blade guide inserts. If the blade hits one of the inserts hard enough, it could damage the insert.

Position 1 1/4" wide blades on the wheels so the gullet is 1/8" (3.0 mm) out from the edge of the wheel. Position 1 1/2" wide blades on the wheels so the gullet is 3/16" (4.5 mm) out from the edge of the wheel.

Close the blade housing covers.

Next, turn the tension handle until the blade is tensioned correctly.

3.6 Tensioning The Blade

Before tensioning the blade, check the air pressure gauge to see that the air tension system is properly charged. The gauge should read 50 PSI, i.e. .34 MPa (yellow colour) with the blade tension completely released. To add air pressure, remove the air valve stem cover and attach an air pump to the air valve. Add air until the gauge reads 50 PSI. To release air, push in the valve stem. Replace the air valve stem cover when finished adjusting the air pressure

See Figure 3-5.

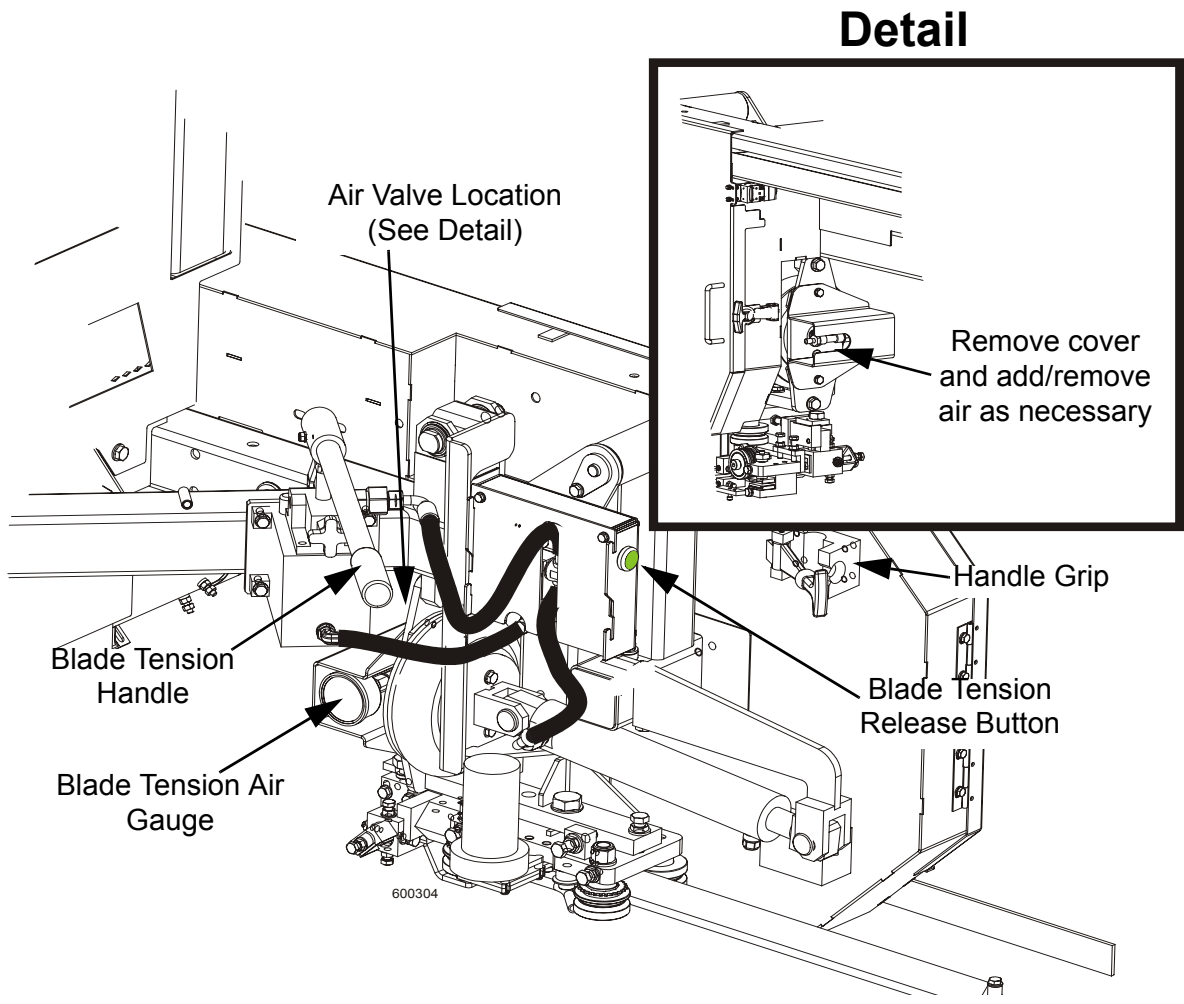

FIG. 3-5

To tension the blade use the tension handle. To release, press and hold the blade tension release button (see figure above). The blade tension handle should be placed in the handle grip when not use.

The tension gauge should be checked occasionally when adjusting the cant control or while cutting. Ambient temperature changes will cause tension to change. Adjust the tension handle as necessary to maintain the recommended tension level.

3.7 Tracking The Blade

1. Turn the key switch to #3 position.
2. Engage the blade switch.



3. Manually spin one of the blade wheels until the blade positions itself on the blade wheels.
4. Check that if the blade is properly positioned on the blade wheels.

See Figure 3-6. Position 1 1/4" wide blades so the gullet is 1/8" (3.0 mm) out from the edge of the blade wheel ($\pm 1/16$ [1.5 mm]). Position 1 1/2" blades so the gullet is 3/16" (4.5 mm) out from the edge of the blade wheel ($\pm 1/16$ [1.5 mm]).

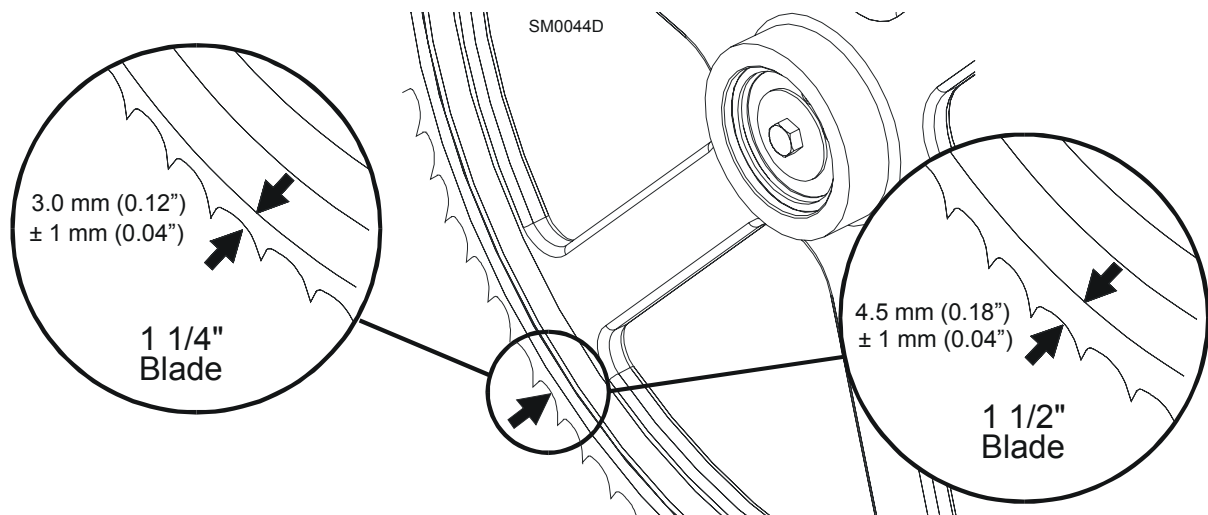

FIG. 3-6

5. Use the cant adjustment bolt to adjust where the blade travels on the blade wheels.

See Figure 3-1.

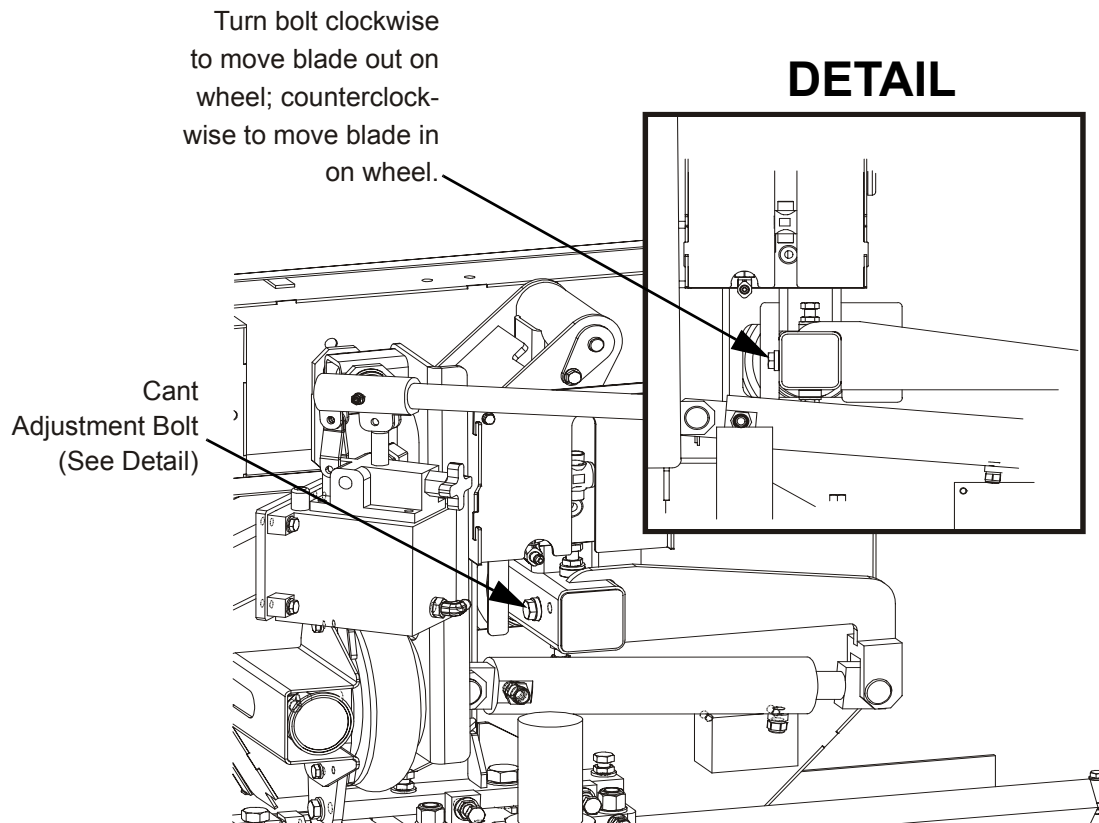

FIG. 3-1

To move the blade out on the blade wheel, turn the cant adjustment bolt clockwise. To move the blade in on the blade wheel, turn the bolt counterclockwise.

NOTE: Slight adjustments of the side bolts on the outer blade wheel are usually all that is necessary to track the blade properly. See Section 7.4 for complete blade wheel alignment instructions.

6. Adjust the blade tension if necessary to compensate for any changes that may have occurred while adjusting the cant control.
7. Spin the blade wheel by hand.
8. Check again the position of the blade on the blade wheels.
9. Repeat Steps 4 - 7 as necessary until the blade tracks on the blade wheels properly.
10. Turn the key switch to #0 position
11. Be sure to close the blade housing and pulley covers when the adjustment is complete.



DANGER! Make sure all guards and covers are in place and secured before operating or towing the sawmill. Failure to do so may result in

serious injury. Be sure the blade housing and pulley covers are closed (i.e. the safety switches located on them are engaged).



IMPORTANT! After aligning the blade on the wheels, always double-check the blade guide spacing and location. ([See Section 7](#) for more information.)

3.8 Starting The Engine (or Motor)

See the appropriate manual supplied with your specific engine/motor configuration for starting and operating instructions.



DANGER! Make sure all guards and covers are in place and secured before operating or towing the sawmill. Failure to do so may result in serious injury. Be sure the blade housing and pulley covers are closed (i.e. the safety switches located on them are engaged).

DANGER! Always be sure that all persons are out of the path of the blade before starting the engine or motor. Failure to do so will result in serious injury.



WARNING! Always wear eye, ear, respiration, safety clothing, and foot protection when operating the sawmill. Failure to do so may result in serious injury.

WARNING! Be sure the power feed switch is in the neutral position before turning the key switch to the #1 or #2 position. This prevents accidental carriage movement which may cause serious injury or death.

DANGER! Check the sawmill wiring every year. Make sure all electrical installation, service and/or maintenance work is performed by a qualified electrician.

WARNING! Hazardous voltage inside the electric box is dangerous. Turn the main switch to the OFF ("0") position and lock out power supply before opening the box door!

WARNING! The door of the electric box can be opened only when the main switch is in the "0" position. The door is closed when the switch is in the "1" position. Serious damage to the box may result while opening the door when the main switch is in the "1" position.



CAUTION! If at any time you need to immediately stop the blade motor, press the emergency stop button located on the control box.

3

Sawmill Setup

Starting The Engine (or Motor)

SECTION 4 SAWMILL OPERATION

4.1 Hydraulic Control Operation

The hydraulic control levers become operational when the contacts at the bottom of the carriage touch the power strip on the frame tube. The hydraulic control levers will only work when the cutting head is close enough to the front end of the mill to touch the power strip.

See Figure 4-1. Hydraulic units have seven control levers to load, clamp, turn and level logs.

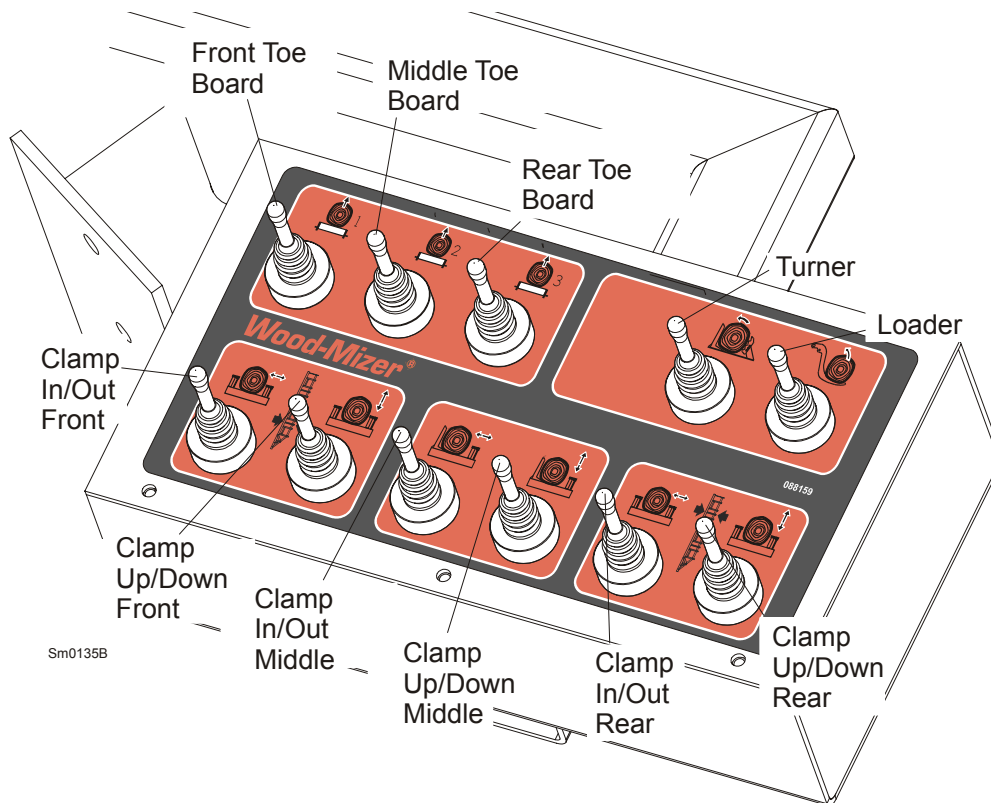

FIG. 4-1

Use the hydraulic control levers to get the mill ready to load a log.

! DANGER! Keep all persons out of the path of moving equipment and logs when operating sawmill or loading and turning logs. Failure to do so will result in serious injury.

! CAUTION! Always make sure the engine is running before operating the hydraulic controls. Operating the controls without the engine running will result in power drainage from the battery. Holding the hydraulic switches halfway up or down also will cause excessive drainage from the battery.

1. Move the clamp out and down so it will not get in the way of logs being loaded onto the bed.



Lower the clamp in/out lever to move the clamp out toward the loading side of the sawmill.



Lower the clamp up/down lever to lower the clamp below bed level.

2. Raise the log loader lever to extend the legs of the log loader out as far as they will go.



3. The chain securing the log loading arm to the bed frame will be tight. Manually push the log loader arm until there is slack in the chain.

4. Unchain the loading arm from the bed frame.

5. Lower the turner lever to completely lower the turner arm. Notice that after the turner arm is all the way down, the side support braces will begin to lower. Release the turner lever after the turner arm is lowered, but before the side supports begin to lower. This stops the log being loaded from damaging the turner and/or falling off the side of the sawmill.



6. When raising the turner lever, the side supports rise first. After reaching a fully vertical position, the turner arm will engage and start to rise.

7. Manually lower the log loader so it rests on the ground.



CAUTION! Be careful when manually lowering the log loader. Do not drop the loader onto the ground.

8. Lower the loader lever to lower the loading arm as far as it will go. Logs must be rolled onto the loading arms one at a time.



9. The front, middle and rear toe boards should be below bed level. Once a tapered log has been loaded, the front or rear end of the log may be lifted to parallel the heart of the log to the path of the blade.



The front toe board is raised by lifting the front toe board lever up. The middle toe board is raised by lifting the middle toe board lever up. The rear toe board is raised by lifting the rear toe board lever up. Once a flat has been made and the log is ready to be turned, push the appropriate toe board lever down to lower either toe board until it falls below the level of the bed.

4.2 Loading, Turning And Clamping Logs

To Load Logs

1. Move the saw carriage to the front end of the frame.



CAUTION! Before loading a log, be sure the cutting head is moved far enough forward so the log does not hit it. Failure to do so may result in machine damage.



CAUTION! Be sure the log clamp, turning arm and toe boards are adjusted out of the path of the log before loading a log onto the bed. Failure to do so may result in machine damage or cause misalignment.

2. Raise the side supports on the sawmill bed to prevent the log from falling off the side of the bed.
3. Use cant hooks or loading equipment to move the log to the foot of the loading arms.
4. Roll the log onto the loader so that it is approximately centered with the sawmill bed. The log turner will operate much easier if the log is centered on the sawmill bed.
5. Raise the loader lever to raise the log onto the sawmill bed. Simply let the loader rise until the log rolls onto the mill bed.



6. Raise the clamp up/down lever to raise the clamp up to prevent the log from rolling off the bed.



Lower the loading arm. You can leave it about halfway down while squaring the log. If you do so, you can use the loading arm to collect boards with bark being sawn on them.



WARNING! After loading the log onto the mill raise the log clamp up to prevent the log from rolling off the bed.

To Turn Logs

1. Raise the turner lever to engage the log turner arm. Let the arm rise until it touches the log and starts to turn it.



2. Spin the log against the side supports until it is turned the way you want it for the first cut. If you want to turn the log more, do the following steps.

3. Engage the clamp by raising the clamp in/out lever. Clamp the log against the side supports.



Lower the turner lever to lower the turner arm below the log.

5. Raise the turner arm to get a new bite on the log.
6. Disengage the clamp.

The log can be turned now. Repeat steps 4 through 7 until the log is turned as desired.

Turning small cants

If you are turning a small cant, use the middle log clamp to turn the cant, instead of the log turner.

1. Lower the clamp up/down lever to lower the clamp below bed level.
2. Use the clamp in/out lever to move the clamp in, beneath the edge of the cant.
3. Raise the clamp up/down lever to raise the clamp and flip the cant.

To Use The Middle Clamp

1. Raise the clamp up/down lever to raise the clamp.



2. Use the clamp in/out lever to clamp the log against the side supports.

3. Lower the turner lever until the turner arm falls below the bed.



Using the clamp in/out lever, back the clamp off slightly.

5. Lower the side supports so that they are positioned below the level of your first few cuts.
6. Using the clamp in/out lever, clamp the log firmly.

Depending on the length of the log being sawn, you can use either the middle log clamp together with the front clamp **and** the rear one (when the log length is minimum 3.5 m), or the middle clamp together with the front clamp **or** the rear clamp (log length below 3.5 m). As the front and rear clamps ensure that the log lies flat on the sawmill bed, they are essential to cut long logs with internal tension accurately.

1. Use the up/down lever of the front/rear clamp to raise the clamp up.
2. Push the in/out lever of the front/rear clamp to move the clamp jaws in.
3. Perform the procedure described above to clamp the log against the side supports.
4. Push the up/down lever of the front/rear clamp to lower the clamp until the log lies flat on the bed.

To Level A Tapered Log



Raise the appropriate lever to raise the front, middle or rear toe board until the heart of the log mea-

sures the same distance from the bed rails at each end of the log.

4.3 Up/Down Operation

This section describes operation of the up/down system with the standard controls. See the operation section of the Accuset or PLC-Network manual for operation of the up/down system using these options.

1. Install a blade, if needed, and check for correct blade tension. ([See Section 3.6](#)).
2. Set the cutting head to the desired height. (The blade height scale shows the height of the blade above the bed rails.)



See Figure 4-2. The up/down switch is located on the far right side of the control panel. Push the switch up to raise the cutting head; push the switch down to lower the cutting head. Hold the switch in position until the cutting head reaches the desired height, then release.

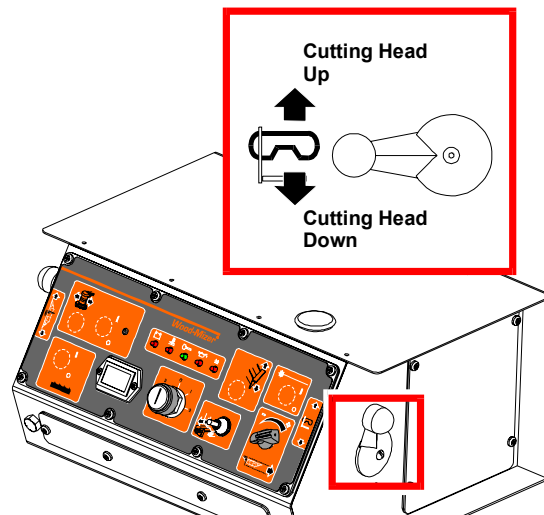

FIG. 4-2

The up/down switch is designed to return to the neutral or "off" position when released. If the switch remains engaged, manually move the switch to the neutral or "off" position. Repair the up/down drum switch.



CAUTION! Always make sure the up/down switch moves to the neutral or "off" position when released to ensure that the saw head stops moving. Failure to do so may result in machine damage.

CAUTION! DO NOT try to force the carriage above the 35" (88 cm) mark or below the 1" (2.54 cm) mark. Damage to the up/down system may result.

4.4 Blade Guide Arm Operation

1. Look down the length of the log to see its maximum width. The outer blade guide should be adjusted to clear the widest section of the log by less than 1" (25.4 mm).
2. Use the blade guide toggle switch on the control panel to adjust the outer blade guide as necessary. Push the switch to the left to move the arm in. Push the switch to the right to move the arm out.

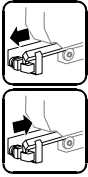

See Figure 4-3.

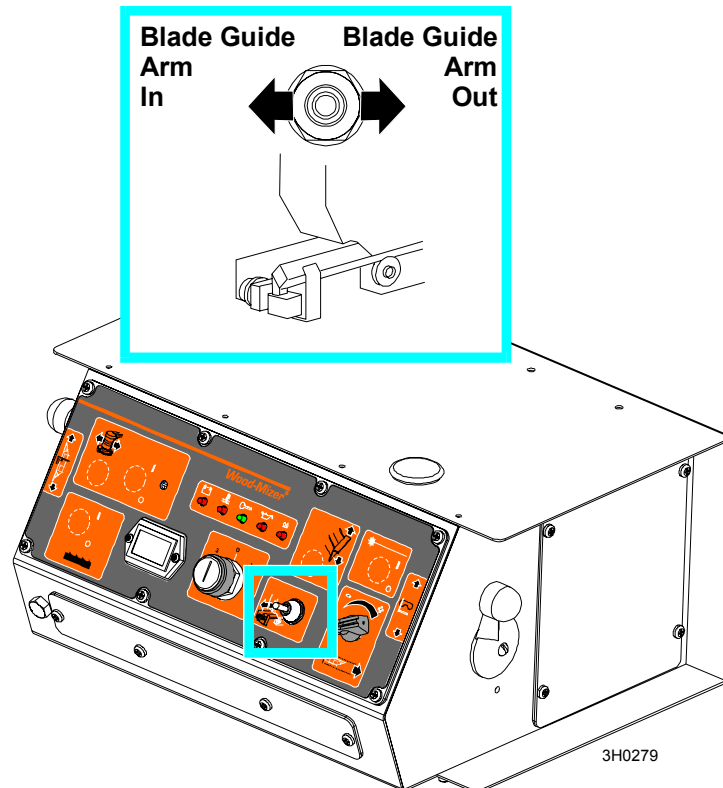

FIG. 4-3

3. Use the blade guide toggle switch to readjust the outer blade guide as you are cutting in order to keep the guide within 1" (2.5 cm) of the log. Be sure to adjust the arm back out before returning the carriage.

4.5 Power Feed Operation

See **Figure 4-4**. The power feed system moves the carriage forward and backward by using two switches on the control panel.

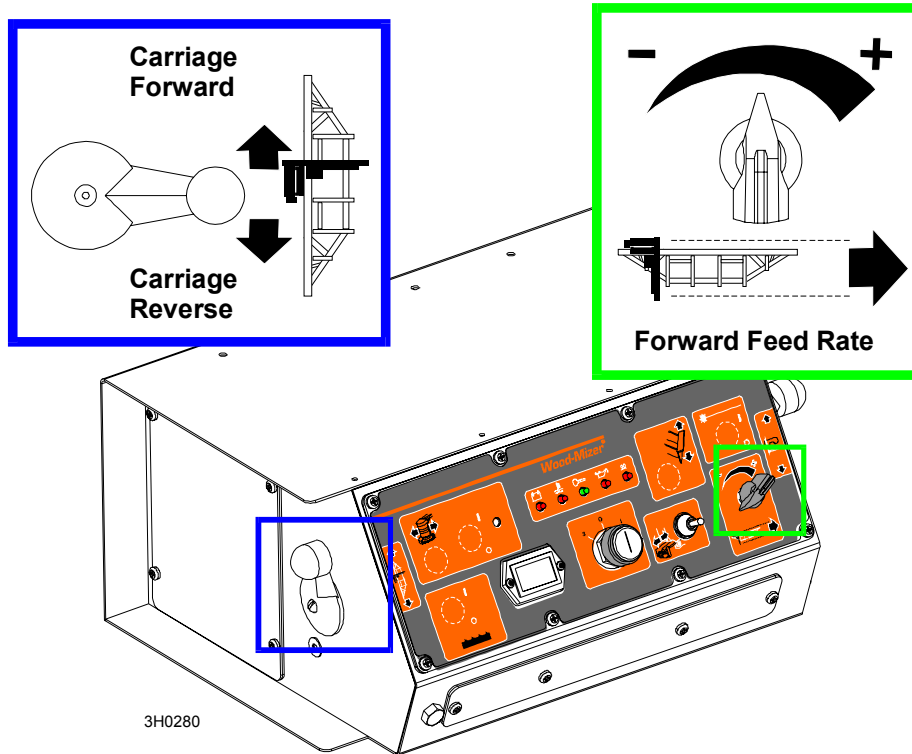

FIG. 4-4

Carriage Feed Rate



The carriage feed rate switch controls the speed at which the carriage travels forward. Turn the switch clockwise to increase speed. Turn it counterclockwise to reduce speed.

Carriage Forward and Reverse



The carriage forward/reverse switch controls the direction in which the carriage travels. Turn the forward/reverse switch upward to move the carriage forward. Turn the switch down to move the carriage backward.



The middle position (as shown) is the neutral position. The power feed switch is designed to return to the neutral or "off" position when released from operating in the reverse position. If the switch remains engaged, manually move the switch to the neutral or "off" position. Repair the drum switch ([See Section 5.5](#)).



WARNING! Be sure the power feed switch is in the neutral position before turning the key switch to the on (#1) or accessory (#2) position. This prevents accidental carriage movement which may cause serious injury or death.

Using The Power Feed

1. To move the carriage forward, push the drum switch handle forward and turn the feed rate switch clockwise.



HINT: To get a straight cut in the first part of the board, feed the blade into the log at a slow speed. This stops the blade from flexing and dipping up or down. Turn the carriage feed rate switch to a slow speed until the whole width of the blade has entered the cut. Then use the carriage feed rate switch to increase the feed rate as desired. Maximum feed rate varies with width and hardness of the wood. Over-feeding results in motor and blade wear, and also produces a wavy cut.



2. Stop the carriage at the end of the cut by turning the carriage feed rate switch counterclockwise until the carriage stops moving. Turn the key switch to the off (#0) position to stop the blade. Remove the board from the top of the log. **Always disengage the blade before returning the carriage for the next cut.**



CAUTION! Be sure to stop the blade when returning the carriage. This will not only prevent the blade from being pulled off and ruined by a wood sliver, but also will increase the life of the blade.

3. Make sure that the blade does not catch on the end of the log. Raise the carriage slightly to make sure the blade clears the log when returned.
4. Return the carriage to the front of the mill by pushing the drum switch handle down. The power feed motor will bypass the carriage feed rate switch and the carriage will automatically return at the fastest speed available.

HINT: Try to stop the blade while the heel of the blade is still on the log. Then bring the carriage back without adjusting the blade up. This lets you keep the blade at the current height setting so you can make the next blade height adjustment more quickly.



DANGER! Stay clear of the area between the trailer axle and saw carriage. Failure to do so will result in serious injury.

4.6 Cutting The Log

The following steps guide you through normal operation of the Wood-Mizer sawmill.

1. Once the log is placed where you want it and clamped firmly, turn the key switch to the #1 position.
2. Use the blade height scale to determine where to make your first cut ([See Section 4.9](#)). The blade height scale will help you to do this. Set the blade to the desired height with the up/down switch. Make sure that the blade will clear all side supports and the clamp. Adjust the outer blade guide to clear the widest section of the log by moving the blade guide toggle switch.



NOTE: An optional laser sight is available to help determine where the blade will travel through the log. See the laser sight manual for detailed operating instructions.

3. Make sure all covers and guards are in place. Push the START button to start the blade spinning.



Start the water lube if necessary to prevent sap buildup on the blade. [See Section 4.10](#).

5. Feed the blade into the log slowly ([See Section 4.5](#)). Once the blade completely enters the log, increase the feed rate as desired. Always try to cut at the fastest speed you can while keeping an accurate cut. Cutting too slowly will waste blade life and lower production!



6. As you get to the end of the log, slow down the feed rate. When the teeth exit the end of the log, turn the feed rate all the way down. Push the STOP button to stop the motor. Remove the slab that you have just cut from the log.



7. Use the carriage forward/reverse switch to return the carriage to the front of the mill. Always disengage the blade before returning the carriage for the next cut.



8. Repeat until the first side of the log is cut as desired. Set aside the usable flitches (boards with bark on one or both sides). You can edge them on the mill later.



9. Lower the toe boards, if they were used. Use the hydraulic levers to release the clamp and engage the log turner. Turn the log 90 or 180 degrees. Make sure the flat on the log is placed flat against side supports if turned 90 degrees. Make sure it is placed on bed rails if turned 180 degrees. If the log was turned 90 degrees and you are using toe boards to compensate for taper in the log, raise the front, middle or rear toe board again on the second side of the log until the heart is parallel with the bed.

10. Repeat the steps used to cut the first side of the log until the log is square. Cut boards from the remaining cant by adjusting the blade height for the thickness of boards that you want.

Example: Remember that the blade cuts a 1/16 - 1/8" (1.6-3.2 mm) wide kerf. If you want 1" (25.4 mm) thick boards, lower the carriage 1 1/16 - 1 1/8" (27-28.6 mm) for each board.

4.7 Edging

The following steps guide you through edging boards on the Wood-Mizer sawmill.

1. Raise the side supports to 1/2 the height of the flitches, or the boards that need to be edged.
2. Stack the flitches on edge against the side supports.
3. Clamp the flitches against the side supports halfway up the flitch height. (Wider flitches should be placed to the clamp side. When they are edged, flip them over to edge the second side without disturbing the other flitches or without having to pull them from the middle of the stack).
4. Adjust the blade height to edge a few of the widest boards.
5. Loosen the clamp and turn the edged boards over to edge the other side.
6. Repeat steps 2-4.
7. Loosen the clamp and remove the boards that have good clean edges on both sides. Clamp the remaining flitches and repeat steps 2-5.

4.8 Optional Cutting Procedure

In order to achieve maximum production rates, it may be desirable to leave the blade engaged when returning the carriage. (Normal operation procedures recommend disengaging the blade before returning the carriage for maximum blade life and fuel economy.)

DANGER! If leaving the blade engaged for maximum production rates, make sure the off-bearer stays out of the path of the blade. Failure to do so will result in serious injury or death.

CAUTION! If you choose to leave the blade engaged; raise the blade to clear the log before returning the carriage. Failure to do so may cause damage to the blade and/or sawmill.

4.9 Blade Height Scale

See Figure 4-5. The blade height scale is attached to the carriage head frame. It includes:

- a blade height indicator
- an inch scale
- a quarter scale

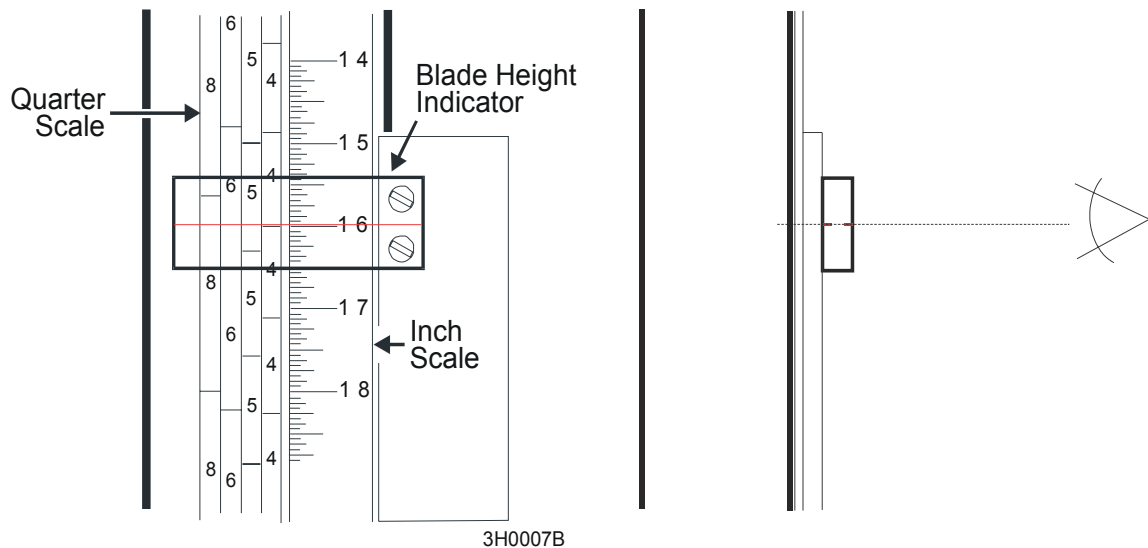

FIG. 4-5

The scales are attached to the frame and move up and down with the carriage head. The blade indicator, used to read the inch and quarter scales, remains stationary.

Blade Height Indicator

The blade height indicator has two horizontal, red lines on both sides. Readings should be taken with eyes level with the indicator, when the two red lines are in line. This will allow to avoid the parallax error (different scale readings depending on the angle of vision).

The Inch Scale

The horizontal red line on the blade height indicator shows how many inches the bottom of the blade is above the bed of the mill. If you know the height of your blade at each cut, you can determine the thickness of lumber you are sawing.

Example: You want to cut 1" (25 mm) random width boards from a log. Position the blade for the first cut. Move the carriage to an even measurement on the inch scale. Make a trim cut. Return the carriage for the second cut and lower it 1 1/8" (29 mm) below the original measurement. (The extra 1/8" (3 mm) allows for saw kerf and shrinkage of the lumber.)

The yellow area on the scale identifies where the blade could encounter a side support or log clamp. Check that these items are below the blade level before sawing.

The Quarter Scale

See Table 4-1. Two quarter scales are provided with four sets of marks. Each set represents a specific lumber thickness. Saw kerf and shrinkage allowance are included, but actual board thickness will vary slightly depending on blade thickness and tooth set.

To choose which scale to use, determine what finished thickness you want to end up with. The Grade Hardwood Quarter Scale provides thicker finished boards usually required by commercial buyers. The Standard Quarter Scale allows for kerf and shrinkage of finished boards suitable for most custom applications. Always check with your customer before you saw to determine what actual finished thickness is required.

Standard Quarter Scale		Grade Hardwood Quarter Scale	
Scale	Actual Board Thickness	Scale	Actual Board Thickness
4/4	1" (25 mm)	4/4	1 1/8" (29 mm)
5/4	1 1/4" (32 mm)	5/4	1 3/8" (35 mm)
6/4	1 1/2" (38 mm)	6/4	1 5/8" (41 mm)
8/4	2" (51 mm)	8/4	2 1/8" (54 mm)

TABLE 4-1

To use the quarter scale, look at the blade height indicator. Line up the horizontal red line on the indicator with the nearest mark on the scale you want to use. Make a trim cut. When you return the carriage for a second cut, lower the carriage to the next mark on the scale. This mark shows where the blade should be positioned to cut a certain thickness of lumber, without having to measure on the inch scale.

Example: You want to cut 1" (25 mm) (4/4) random width boards from a log. Position the blade for the first cut. Adjust the quarter scale so a 4/4 mark is aligned with the red line on the indicator. Make a trim cut. Return the carriage for the second cut. Now, instead of having to measure down 1 1/8" (29 mm) on the inch scale, you can simply lower the blade so the indicator is aligned with the next 4/4 mark on the quarter scale. Turn the log 90 degrees and repeat.

4.10 Water Lube Operation

The Water Lube System keeps the blade clean. Water flows from a 5-gallon (18.9 liter) bottle through a hose to the blade guide where the blade enters the log. A valve in the bottle cap controls the amount of water flow.

See Figure 4-6.

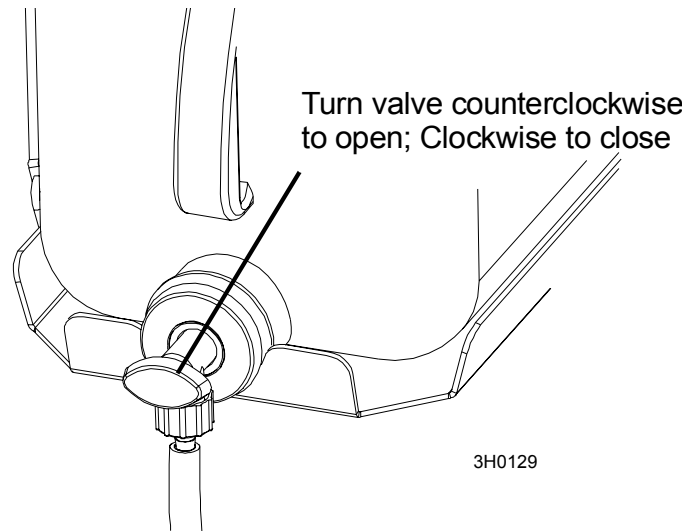

FIG. 4-6

A solenoid valve will automatically start the water flow when the power feed is activated in the forward direction. The solenoid will stop the water flow when the feed switch is returned to the neutral position.

Not all types of wood require the use of the Water Lube System. When it is needed, use just enough water to keep the blade clean. This saves water, and lowers the risk of staining the boards with water. Usual flow will be 1-2 gallons (3.8-7.6 liters) per hour.

Before removing the blade, engage the blade. Let the blade spin with water running on it for about 15 seconds. This will clean the blade of sap buildup. Wipe the blade dry with a rag before storing or sharpening.

For further lubrication benefits, add one 12oz. bottle of Wood-Mizer Lube Additive to 5 gallons of water. Wood-Mizer Lube Additive enables some previously impossible timbers to be cut by significantly reducing resin buildup on the blade. It helps to reduce heat buildup, wavy cuts, and blade noise. This biodegradable and environmentally friendly pre-mix includes a water softener additive, so it works with hard water.



WARNING! Use ONLY water and Wood-Mizer Lube Additive with the water lube accessory. Never use flammable fuels or liquids such as diesel fuel. If these types of liquids are necessary to clean the blade, remove it and clean with a rag. Failure to do so can damage the equipment and may result in serious injury or death.

If you are sawing in freezing temperatures, remove the water lube bottle from the sawmill when done sawing and store it in a warm place. Blow any remaining water from the water lube hose.

See the separate LubeMizer System manual for operation instructions.

4.11 Preparing The Sawmill For Towing

The Wood-Mizer trailer package makes transporting your sawmill easy and convenient. To get your sawmill ready for towing, follow these instructions.

1. Move the saw carriage to the front end of the sawmill. Raise the rear outriggers.

See Figure 4-7. Secure outrigger with both Locking Pin and Travel Lock Pin.

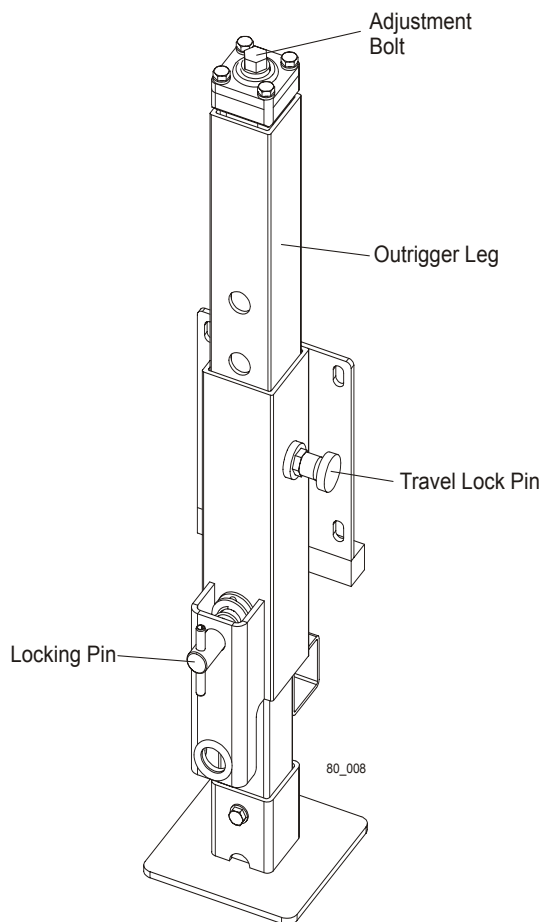



FIG. 4-7. ADJUSTABLE OUTRIGGER.



CAUTION! Be sure the outrigger base is adjusted properly before securing in travel position with the lock pin.

 **CAUTION!** Do not adjust the outrigger base height while there is weight on it. Damage to the outrigger may result.

2. Move the clamp all the way in toward the main bed frame tube.

 **CAUTION!** Move the hydraulic clamp and turner to provide maximum ground clearance before towing. Failure to do so may result in damage to the sawmill.

3. Move the carriage forward to the travel position over the rear bed rail. Position the hole in the saw head over the travel rest pin.
4. Move the rest pin to its travel position. Secure the rest pin using locking pin.

See Figure 4-8.

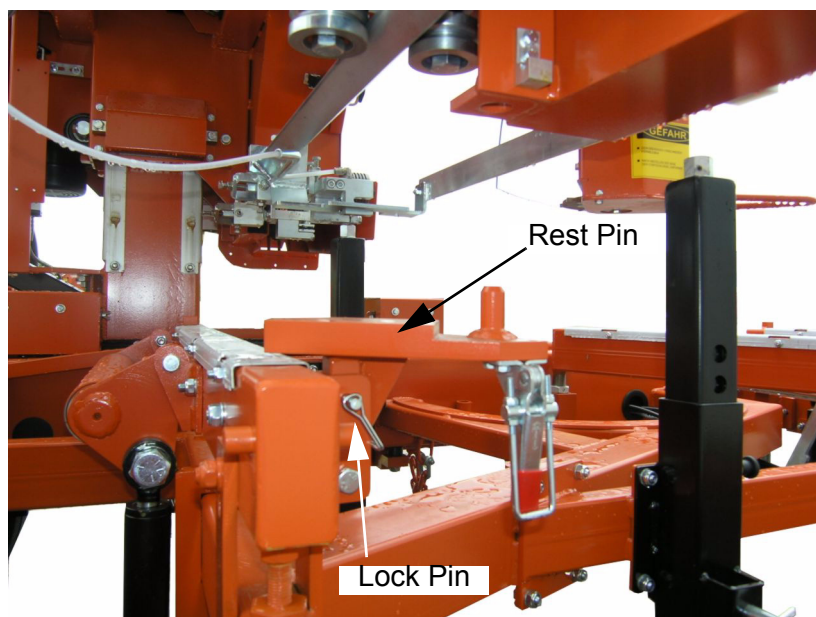

FIG. 4-8

5. Lower the saw head until it contacts the stop blocks on the mast rails. Secure the saw head with locking clamp.

See Figure 4-9.

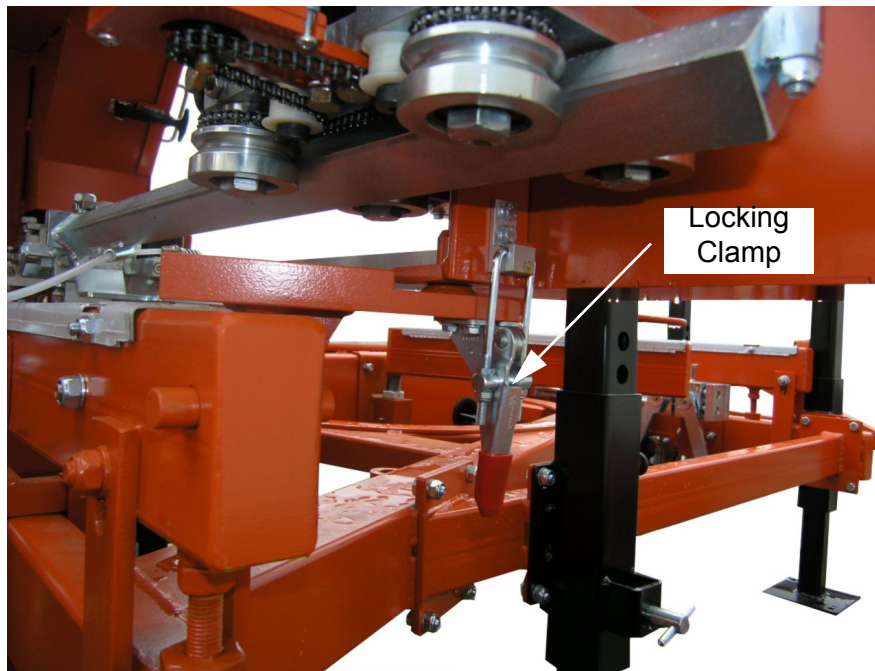

FIG. 4-9



CAUTION! It is important that the lower stop bolts are properly adjusted to secure the carriage on the track rail. Failure to properly adjust the stop bolts can cause saw head damage, especially during mill transportation.

6. If necessary, adjust the stop located at the bottom of the mast so the saw head contacts them after it is lowered 3/4" (19mm) past where it contacts the rest pin.

See Figure 4-10.

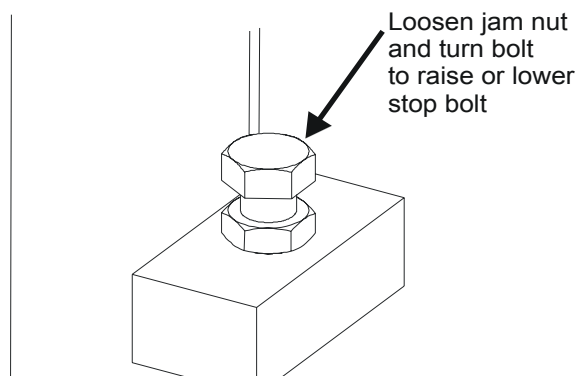

FIG. 4-10

7. Use the hydraulic controls to raise the log turner and loader as high as they will go. Manually lift the loader and hook the loader chains to the sawmill frame. Use the hydraulic loader lever to lower the loader until the chains are tight. Push the loader lever down to bring the loader feet up to the loader arms.

8. Hook the carriage safety chain located at the bottom of the carriage to the bracket at the bottom of the mast.

See Figure 4-11.

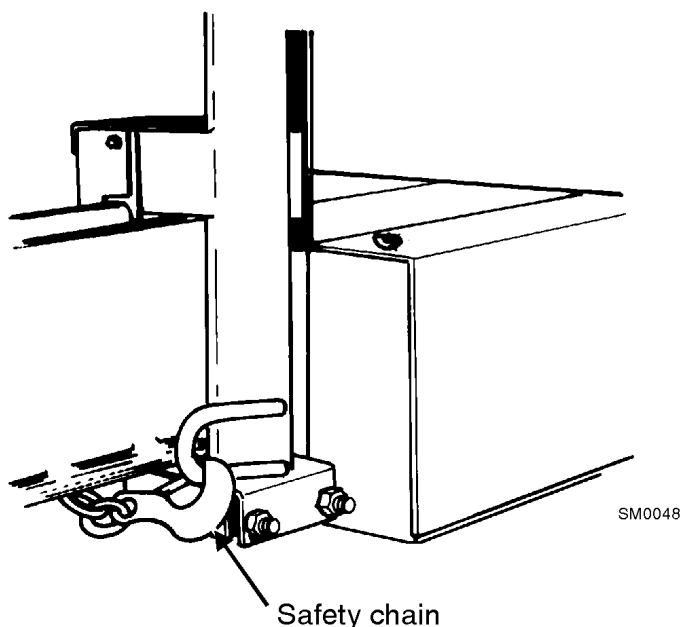

FIG. 4-11



CAUTION! Check to be sure the saw head safety chain is secured before towing the sawmill. Failure to properly secure the saw head can result in severe machine damage. Be sure the blade housing and pulley covers are in place and secure. Use the safety retainer pin and cable to fasten blade housing covers.

9. Remove all loose objects from the bed of the mill.
10. Place both fenders in the slots located behind the trailer tires. Raise and secure all but the very front outrigger.

See the trailer operator's manual for specific information regarding hitch operation and towing the sawmill.

SECTION 5 MAINTENANCE

This section lists the maintenance procedures that need to be performed.

See the [Maintenance Log](#) located after this section for a complete list of maintenance procedures and intervals. Keep track of machine maintenance by filling in the machine hours and the date you perform each procedure.

 **This symbol** identifies the interval (hours of operation) at which each maintenance procedure should be performed.

Be sure to refer to option and engine manuals for other maintenance procedures.

5.1 Wear Life

See Table 5-1. This chart lists estimated life expectancy of common replacement parts if proper maintenance and operation procedures are followed. Due to the many variables which exist during sawmill operation, actual part life may vary significantly. This information is provided so that you may plan ahead in ordering replacement parts.

Part Description	Estimated Life
Up/Down Motor Brushes	1000 hours
Up/Down Motor	2000 hours
Hydraulic Pump Solenoid	750 hours
Power Feed Motor Brushes	750 hours
Up/Down Drum Switch	1000 hours
Hydraulic Pump Motor Brushes	750 hours
Power Feed Drum Switch	1200 hours
Drive Belt	1250 hours
Power Feed Motor	1500 hours
Up/Down Belt	2000 hours

TABLE 5-1

5.2 Blade Guides

1. Check the rollers for performance and wear every blade change. Make sure the rollers are clean and spinning freely. If not, rebuild them. Replace any rollers which have worn smooth or have become cone shaped.

Steel Guide Blocks

2. Inspect the blocks at every blade change for damage or wear.

As the blocks wear, the front inside corner will wear more than the body of the block. When the corner wears far enough, sawing performance will be affected even if the body of the block is adjusted properly to the blade. At this point, the block should be replaced. If you have access to the appropriate equipment, you can grind or mill the blocks to a new flat surface and reuse them. It is recommended you develop a routine schedule for replacing the blade guide blocks based on your sawing conditions and experience.

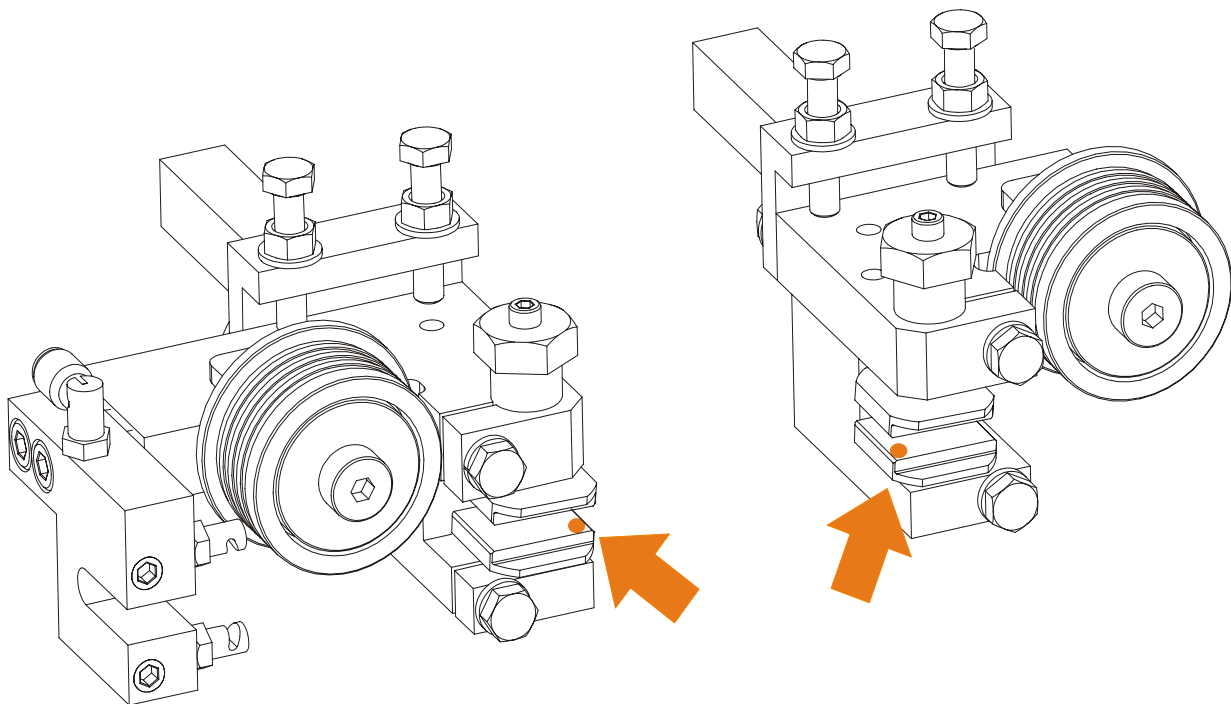

RYS. 5-0

3. Check the ceramic inserts are properly spaced from the bottom of the blade every 25 hours of operation. As the rollers wear, the gap between the blade and inserts will become larger. Use the provided shim or a feeler gauge to check the inserts are adjusted 0,3-0,5 mm from the blade.

25

See Figure 5-1. To adjust the disks up, loosen the bottom guide disk mounting bolt and clamp bolt. Use the provided adjustment tool. to raise bottom disk Retighten the bottom disk mounting bolt and clamp bolt. See Section: "[See Section](#)."



IMPORTANT! The ceramic inserts should be parallel to the blade. Check the space between the insert and the blade at each side of the insert to insure it is parallel. Use the appropriate outer adjustment bolt

to tilt the insert mounting plate so the insert is parallel to the blade.

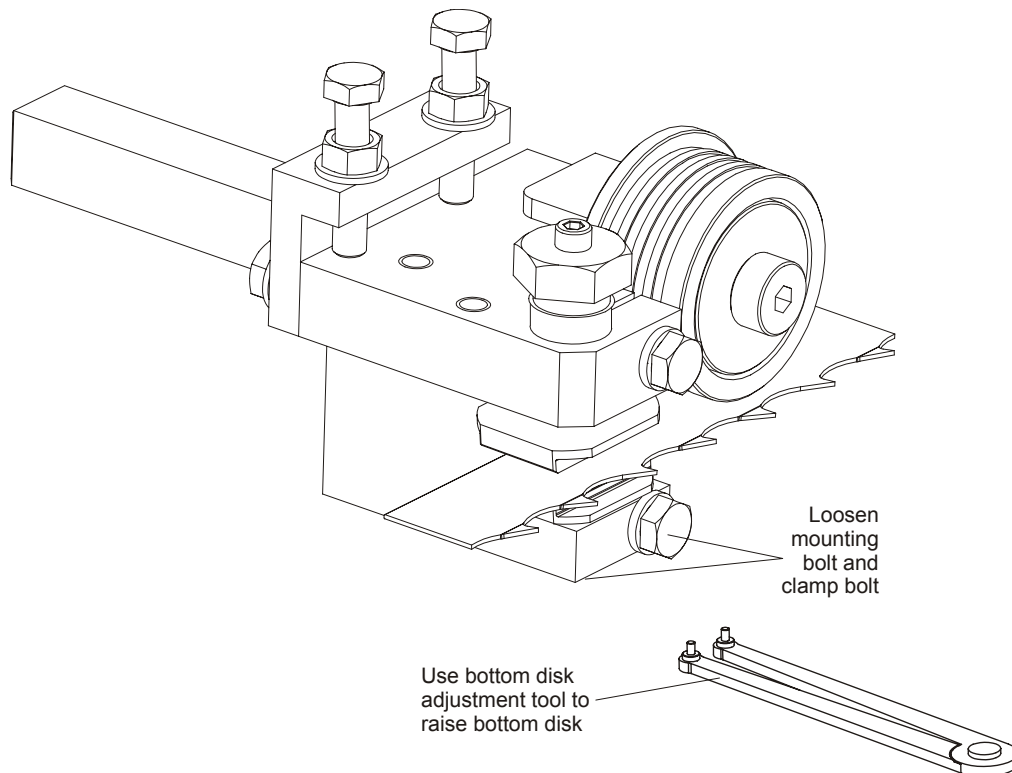

FIG. 5-1

After adjusting the drive side blade guide block insert up, check the deflector. If necessary, loosen the two deflector mounting screws and adjust the deflector so it does not touch the blade.

A/R Inspect the blade guide assemblies for proper alignment everytime you change the blade. [See Section 8.1](#) for blade guide adjustment instructions.

WARNING! Blade guide alignment is essential for optimal cutting performance, blade life and safety. Failure to check and maintain proper blade guide alignment will result in stress cracks forming in the blade. These cracks will lead to premature blade breakage. If the blade breaks during operation and the blade has multiple stress cracks, the blade could shatter into several pieces and escape from the protective guards of the sawmill. Small blade pieces projected into the area around the sawmill creates a safety hazard for the operator and any bystanders surrounding the mill.

WARNING! DO NOT use blades with stress cracks. Blades with stress cracks can shatter causing bodily injury and/or machine damage.

Preventing sap buildup on the blade is critical when using the high-performance blade guide system. If the wood you are sawing leaves sap buildup using plain water in the blade lube system, use Wood-Mizer lube additive (part no. 033439).

Throat Screw

Make sure the blade screw in the top center of the C-frame is 1/16" (1.5 mm) away from the blade. If not, loosen the nut and adjust the screw as necessary. Check the screw every blade change. Failing to maintain this adjustment will lead to early blade breakage.

See Figure 5-2.

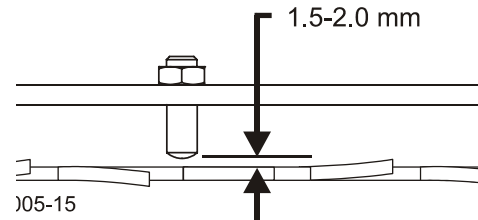

FIG. 5-2

5.3 Sawdust Removal

1. Remove the excess sawdust from the blade wheel housings and sawdust chute every blade change. AR
2. Remove all sawdust and debris from around the velocity fuse valves every 8 hours of operation. The valves are located at the bottom of the log loader cylinders. 8
3. Remove sawdust buildup as necessary from the battery box lid and top rail cover.
4. Remove sawdust buildup from the track rail cover.



CAUTION! Failure to remove sawdust buildup from the battery box lid and/or track rail cover could result in damage to these parts when the saw head is lowered to its lowest position.

5.4 Carriage Track, Wiper & Scrapers

Properly maintaining the sawmill carriage track is critical in preventing corrosion that can cause pitting and scaling on the rail surfaces. Pitted and scaled surfaces can, in turn, cause rough cuts or jerky power feed movement.

See Figure 5-3.

1. Clean track rails to remove any sawdust and sap buildup every eight hours of operation. 8

Use a light-grade sandpaper or emery cloth to sand off any rust or other adhering particles from the rails.



CAUTION! Keep track rails free of rust. Formation of rust on the track rail in the areas where the cam bearings roll can cause rapid deterioration of the track rail's surface.

Lubricate the rails by wiping them with Dexron III ATF transmission fluid, 10W30 motor oil, or 3-in-1 turbine oil. Oil lubrication will help protect the rails from corrosive elements such as acid rain and/or moisture from nearby bodies of saltwater (if applicable). This lubrication is essential to maintain the integrity of the track rails and track rollers and to achieve long service life.

- 2.** Remove sawdust from the track roller housings and lubricate the felt track wiper every twenty-five hours of operation.

Remove the track roller housing covers and brush any sawdust buildup from the housings.

- 3.** Check the track scrapers as needed. Make sure the scrapers fit firmly against the rail. If a track scraper needs to be adjusted, loosen the screw, push the scraper downward until it fits firmly against the rail, and retighten the thumb screw.

Clean and lubricate the upper track wiper every twenty-five hours of operation. Unbolt the wiper, remove it from the sawmill, and remove any sawdust buildup. Soak the felt wiper with Dexron III transmission fluid, 10W30 motor oil or 3-in-1 turbine oil.



CAUTION! Reinstall the track wiper so that it lightly touches the track rail. If the wiper presses too firmly against the rail, it can cause the power feed to bind.

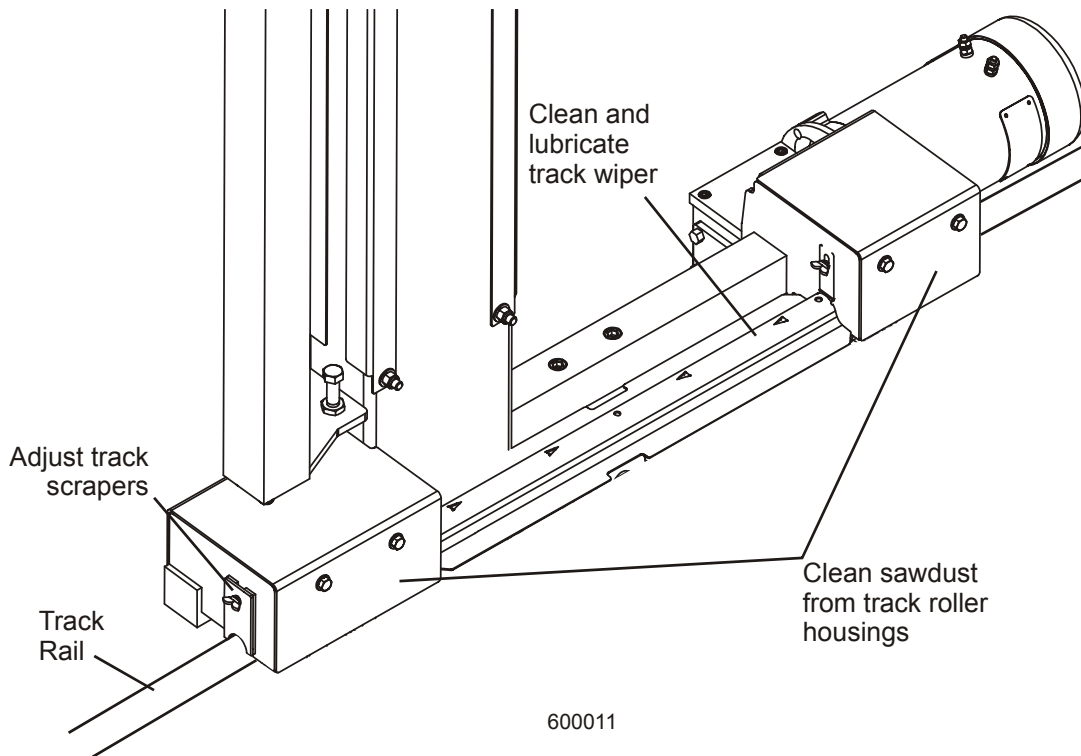

FIG. 5-3

5.5 Vertical Mast Rails

- 50 Clean and lubricate the vertical mast rails every 50 hours of operation. Clean with solvent and remove any rust with a light-grade sand paper or emery cloth. Lubricate the mast with motor oil or automatic transmission fluid (ATF).



CAUTION! Never use grease on the mast rails as it will collect sawdust.

5.6 Drum Switches

- 50 Lubricate the up/down and power feed drum switch contacts inside the control panel every fifty hours of operation. Use only contact grease supplied by Wood-Mizer. Remove the control panel cover. Use a cotton swab to apply grease to the switch contact ends.



WARNING! Drum switch grease contains Petroleum Hydrocarbon Lubricant. Eye and skin irritant. If introduced into eyes, flush with water for at least 15 minutes. If film or irritation persists, seek medical attention. Wash skin with soap and water. If ingested, do not induce vomiting - contact a physician. KEEP OUT OF THE REACH OF CHILDREN.

5.7 Miscellaneous

- 50 1. Oil all chains with Dexron III ATF every fifty hours of operation.



CAUTION! Do not use chain lube. It causes sawdust buildup in chain links.

- 50 2. Apply a thin film of a NLGI No. 2 grade lithium grease to the blade guide arm every fifty hours of operation to help prevent it from rusting.

- AR 3. Adjust the blade guide arm drive chain as necessary. To adjust the chain, loosen the blade guide arm motor mounting plate bolts and slide the motor to take slack out of the chain.

- 50 4. Grease the clamp mechanism, loading arms and side supports with a NLGI No. 2 grade lithium grease every fifty hours of operation.

5. Check the mill alignment every setup ([See Section SECTION 7](#)).

6. Make sure all safety warning decals are readable. Remove sawdust and dirt. Replace any damaged or unreadable decals immediately. Order decals from your Customer Service Representative.

- 150 7. Lubricate the actuator arm, bracket and braking lever axis every 150 hours of operation with a NLGI

No. 2 grade lithium grease. Apply grease to the grease fitting shown below.

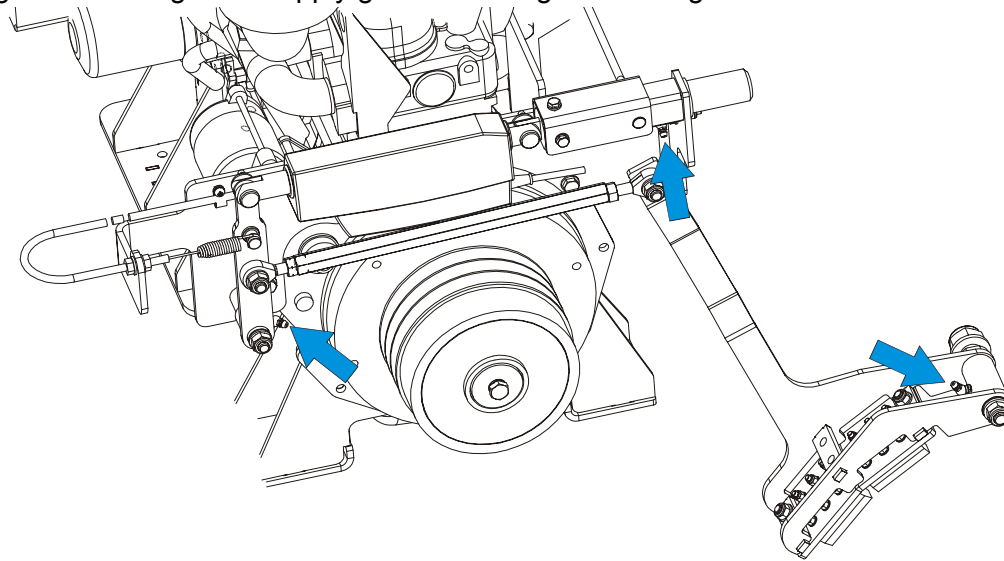

5.8 Brake Adjustment

1. The engine RPM should be 1150 when idling and 3000 when running.
2. The throttle cable mounting bolt should be placed in the middle hole of the acceleration lever located on the engine.

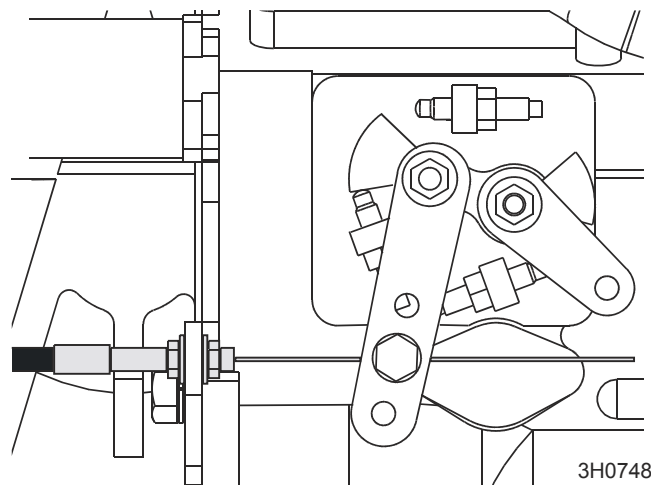

3. Adjust the brake using turnbuckle so that, the braking time is about 5 seconds and the brake blocks

are not touching the blade wheel with the linear actuator fully closed (minimum actuator length).

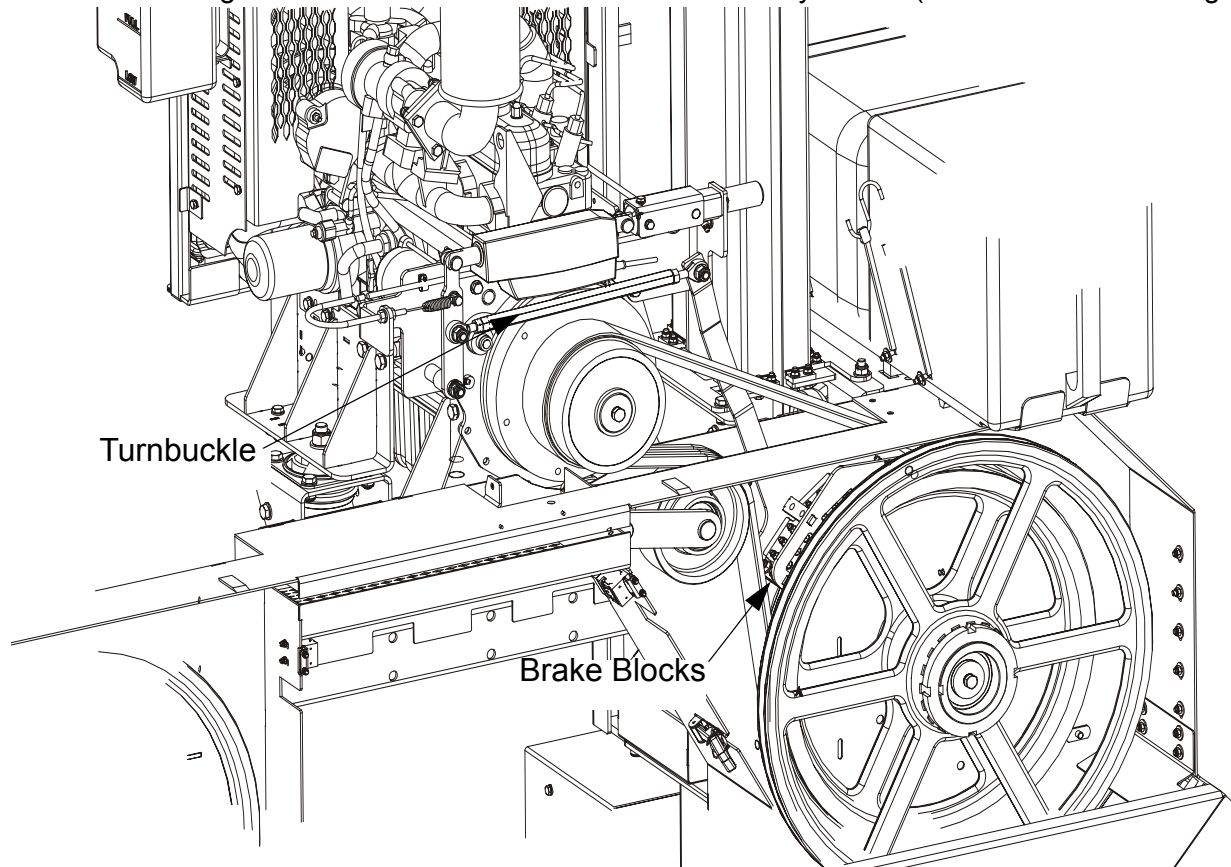

4. With the actuator fully opened (maximum actuator length) during braking, the spring supporting the actuator should be deflected as well as the spring guard along with the actuator mount block with shaft should slide.
5. Never increase the engine RPM by moving manually the acceleration lever on the engine. Increasing the engine RPM when the brake is engaged will result in quick clutch damage.
6. The throttle cable should move smoothly and easily in the housing.

5.9 Drive Belt Adjustment

 **DANGER!** Never adjust the drive belts and the drive belt bracket while the motor is running. Failure to do so may result in serious injury.

 Periodically check the drive belt for wear. Replace any damaged or worn belts as needed.

See Figure 5-4. Adjust proper drive belt tension using the bolt located between the drive side wheel covers. To tighten drive belt turn the bolt clockwise. To loosen drive belt turn the bolt counter-clockwise.

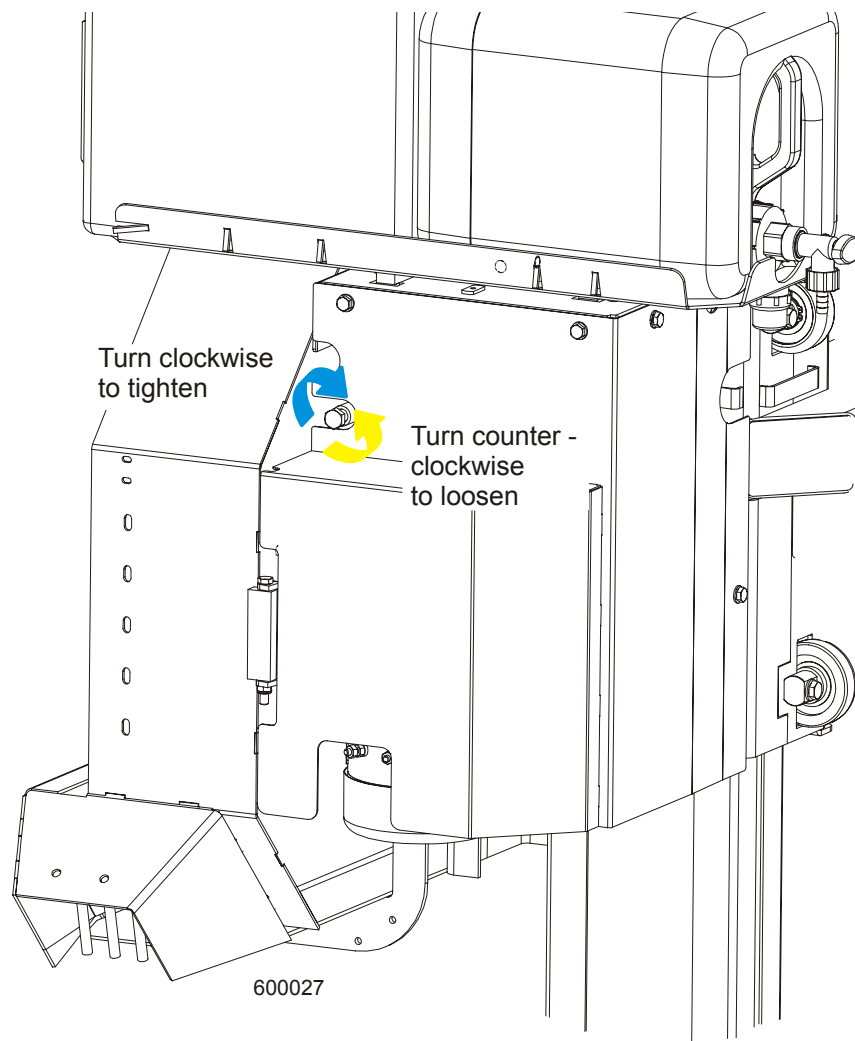

FIG. 5-4

5.10 Up/Down System

750

Adjust the up/down chain tension as needed. Measure chain tension with the head all the way to the top of the vertical mast. Find the chain adjusting bolt at the bottom of the mast. Use the adjustment nut to adjust the bolt until the center of the chain can be deflected 3/4" (1.9cm) with a 5 lb. (2.3 KG) deflection force.



CAUTION! Do not over-tension the chain. Over-tensioning the chain may lead to early failure of the gear reducer.

1. Adjust the motor belt tension as needed. To do this, loosen the motor mounting bolts and turn adjust-

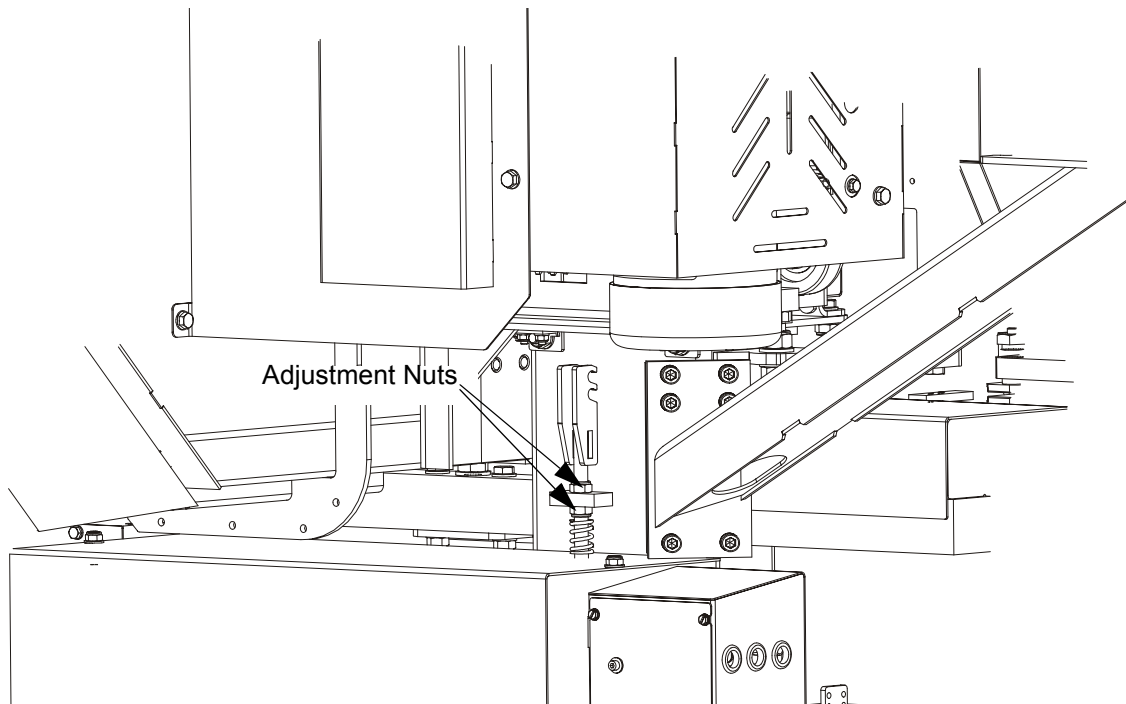

FIG. 5-4

ment bolts clockwise or counterclockwise evenly, until the belt is properly tensioned. Tighten the motor mounting bolts.

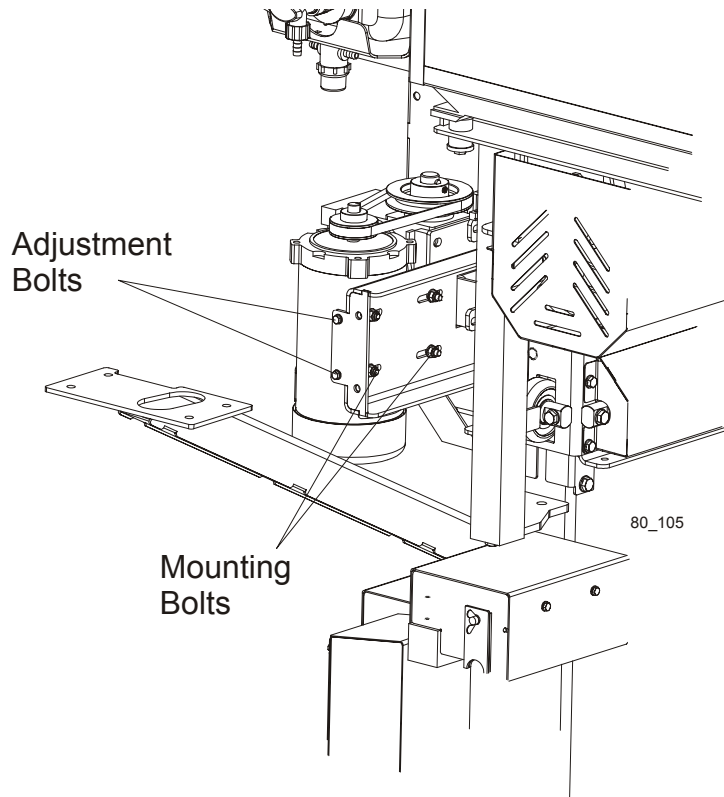

FIG. 5-4

AR Periodically check the belt for wear. Replace any damaged or worn belts as needed.

2. When oil leaks from the gear reducer please contact Customer Service.
3. Check the up/down gearbox oil level. Add a synthetic gear oil such as Mobil SHC 634 as needed.

Drain and refill the gearbox with 25 ounces of oil after every 5000 hours of sawmill operation or once a year, whichever comes first.

Wood-Mizer offers replacement gear oil in 8 ounce bottles.

4. 750 Inspect the up/down motor brushes every 750 hours of operation. Remove brush dust and replace the brushes if they worn to a length of 5/8" or shorter.



CAUTION! Do not operate the up/down system if the motor brushes are worn shorter than 5/8". Damage to the up/down motor may result.

5.11 Charging The Battery (DC Only)



DANGER! Batteries expel explosive gases. Keep sparks, flames, burning cigarettes, or other ignition sources away at all times. Always wear safety goggles and a face shield when working near batteries. Failure to do so will cause serious injury.¹



WARNING! Battery posts, terminals and related accessories contain lead and lead compounds, chemicals known to the State of California to cause cancer and reproductive harm. Wash hands after handling.



WARNING! Charge the battery in a well ventilated area. Do not attempt to charge a frozen battery.

Use extreme care to avoid spilling or splashing electrolyte (which is dilute sulfuric acid) as it can destroy clothing and burn the skin. If electrolyte is spilled or splashed on clothing or the body, it should be neutralized immediately and then rinsed with clean water. A solution of baking soda, or household ammonia, and water may be used as a neutralizer.

Electrolyte splashed into the eyes is extremely dangerous. If this should happen, force the eye open and flood it with cool, clean water for approximately fifteen minutes. A doctor should be called immediately when the accident occurs and “on-the-spot” medical attention given if possible. If a doctor cannot come to the scene of the accident immediately, follow his instructions concerning actions to take. Do not add eye drops or other medication unless advised to do so by the doctor. Do not place a battery or acid within the reach of children. If acid (electrolyte) is taken internally drink large quantities of water or milk. Follow with milk of magnesia, beaten egg or vegetable oil. Call a physician immediately.

If electrolyte is spilled or splashed on any surface of the machine, it should be neutralized and rinsed with clean water.



CAUTION! Do not overcharge the battery. Overcharging may reduce the overall service life of the battery.

CAUTION! Be sure the battery is fully charged before transporting the sawmill. If the battery is not fully charged, excessive vibration could reduce the overall service life of the battery.

NOTE: A fuse terminal extension stud is provided in the fuse box. The extension may be used to temporarily connect a battery charger or jumper cables to raise the saw head from the towing position so the battery box lid can be removed. [See Section 6.8](#) for instructions con-

1. Battery Council International, copyright 1987

cerning the fuse terminal extension stud.

1. Raise the saw head to access the battery box.

IMPORTANT: Be careful not to overcharge the battery, especially when using a high-rate or “boost” charger (40 amps or higher). These are intended to quickly charge a good battery that is discharged. They are not intended for unattended or long-term charging.

2. After the battery is completely recharged, remove the negative charger/jumper cable from ground.
3. Remove the positive charger/jumper cable from the battery.
4. Replace the battery box lid and replace the flat washers and nuts.

5.12 Hydraulic System

1. Check the hydraulic fluid level every fifty hours of operation. Add fluid as necessary. The level in the hydraulic pump should be 3/4" (19mm) from the top with all cylinders collapsed.

If humidity is a problem or the mill is used outside in humid weather, drain and replace two quarts (.95 liters) of fluid every six months. This will drain any accumulated water and help prevent pump failure due to water ingestion. It also will prevent excessive fluid wear and allow the fluid to maintain its hot end performance. If humidity is not a problem, drain and replace one gallon (3.8 liters) of fluid every year to prevent fluid wear.

See Figure 5-5. If you are operating in temperatures -20° to 100° F (-29° to 38° C), use an all-weather hydraulic fluid such as Exxon Unavis J26. For alternate fluids and/or other temperature ranges, refer to the chart below. Operating above the recommended temperature range of a fluid could result in excessive pump wear. Operating below the recommended temperature range could result in reduced hydraulic cylinder speed. To change fluid types, replace one gallon of the current fluid with one gallon of the alternate fluid.

TEMPERATURE

F -30° -20° -10° 0° 10° 20° 30° 40° 50° 60° 70° 80° 90° 100° 110° 120°
 C -35° -29° -23° -18° -12° -7° -1° 5° 10° 16° 21° 27° 32° 38° 44° 49°

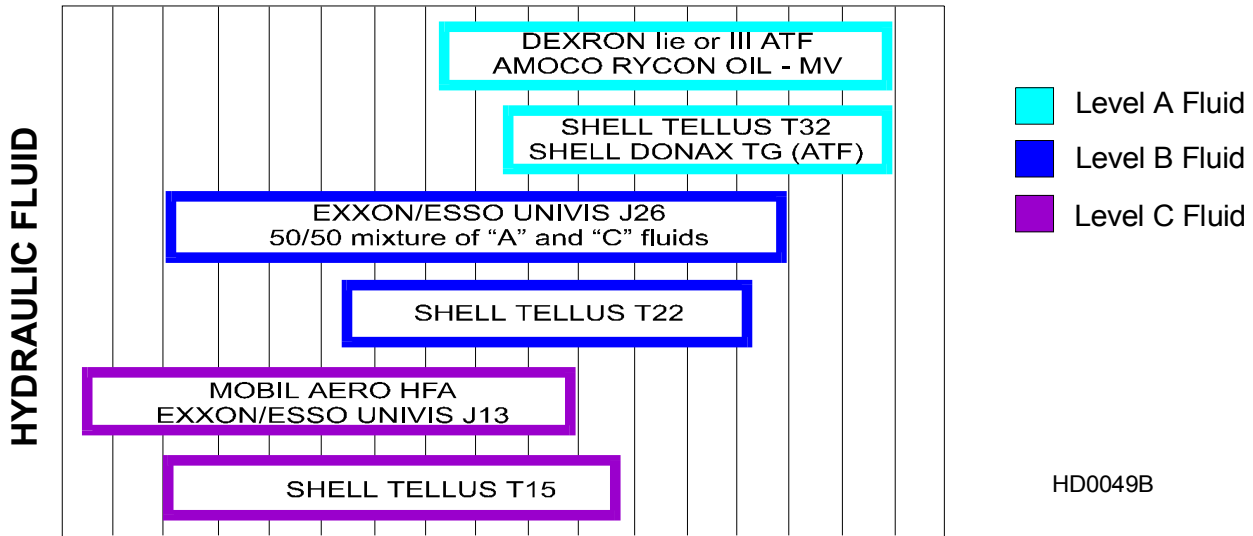

FIG. 5-5

2. Replace the hydraulic system cartridge filter every 500 hours of operation.
3. Inspect the hydraulic pump motor brushes every 750 hours of operation. Remove brush dust and replace the brushes if they worn to a length of 1/4" or shorter.



CAUTION! Do not operate the hydraulic system if the pump motor brushes are worn shorter than 1/4". Damage to the pump motor may result.

4. Periodically check all hydraulic lines and fitting as needed. Replace as necessary.

5.13 Power Feed

1. Adjust the power feed chain as needed. Measure the power feed chain tension with the saw head all the way toward the front of the mill. Use the adjustment nut on the feed tensioner at the front of the mill to tighten or loosen the power feed chain. Adjust the chain until it measures 7 to 8 inches (17.8 to 20.3 cm) from the top of the top rail at its lowest point.



CAUTION! Do not overtighten the feed chain. Damage to the gear reducer may result.

See Figure 5-6.

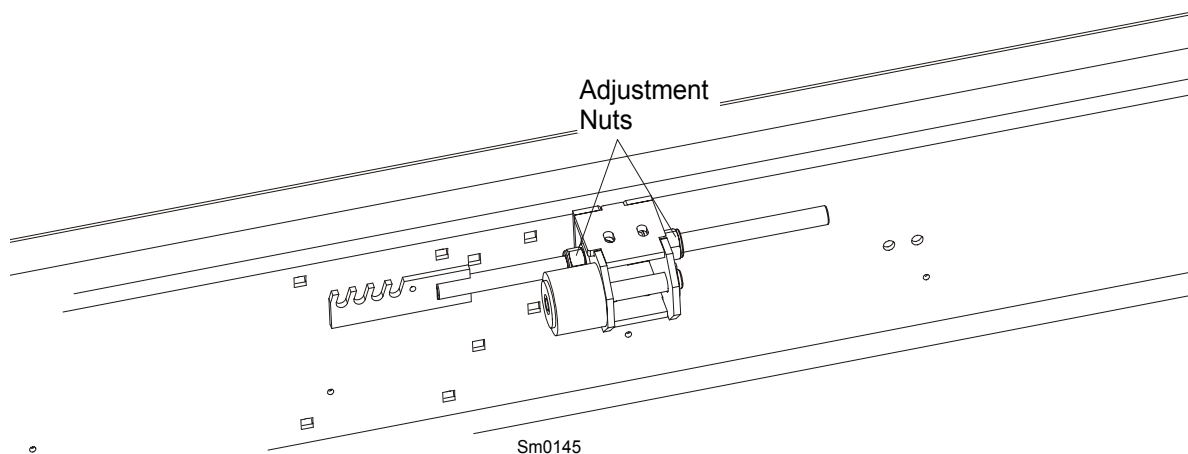

FIG. 5-6

2. Inspect the power feed motor brushes every 750 hours of operation. Remove brush dust and replace the brushes if they worn to a length of 5/8" or shorter.

750



CAUTION! Do not operate the power feed system if the feed motor brushes are worn shorter than 5/8". Damage to the feed motor may result.

3. Check the power feed gearbox oil level. Add a synthetic gear oil such as Mobil SHC 634 as needed.

Drain and refill the gearbox with 25 ounces of oil after every 5000 hours of sawmill operation or once a year, whichever comes first.

Wood-Mizer offers replacement gear oil in 8 ounce bottles.

MAINTENANCE LOG

(Check Engine And Option Manuals For Additional Maintenance Procedures)

Check Blade Screw	See Section 5.2	Daily - Every Blade Change	DAILY MAINTENANCE PROCEDURES
Check Blade Guide Performance	See Section 5.2	Daily - Every Blade Change	
Remove Excess Sawdust From Blade Wheel Housings And Sawdust Chute	See Section 5.3	Daily - Every Blade Change	
Clean Sawdust From Hydraulic Loader Fuses, Battery Box Lid & Track Cover	See Section 5.3	Daily - Every 8 Hours	
Clean And Lubricate Track	See Section 5.4	Daily - Every 8 Hours	
Remove Sawdust From Upper Track Roller Housings	See Section 5.4	Bi-Weekly - Every 25 Hours	
Clean And Lubricate Upper Track Wiper	See Section 5.4	Bi-Weekly - Every 25 Hours	

PROCEDURE	REFERENCE	TOTAL HOURS OF OPERATION FILL IN THE DATE AND THE MACHINE HOURS AS YOU PERFORM EACH PROCEDURE. A SHADED BOX INDICATES MAINTENANCE IS NOT NEEDED AT THIS TIME.									
		50 HRS	100 HRS	150 HRS	200 HRS	250 HRS	300 HRS	350 HRS	400 HRS	450 HRS	500 HRS
Lubricate drum switches	See Section 5.5										
Grease pivot points and bearings/Oil chains	See Section 5.6										
Lubricate blade tensioner screw	See Section 5.6										
Check brake strap tension	See Section 5.8										
Check belt tensions	See Section 5.9 See Section 5.11										
Check feed & up/down chain tensions	See Section 5.11 See Section 5.12										
Check up/down & power feed gear box fluid levels	See Section 5.11 See Section 5.12										
Inspect hydraulic lines & fittings	See Section 5.10										
Check hydraulic fluid level	See Section 5.10										
Replace hydraulic system filter	See Section 5.10										
Inspect hydraulic pump, power feed and up/down motor brushes	See Section 5.10 See Section 5.11 See Section 5.12										

MAINTENANCE LOG

PROCEDURE	REFERENCE	TOTAL HOURS OF OPERATION									
		FILL IN THE DATE AND THE MACHINE HOURS AS YOU PERFORM EACH PROCEDURE. A SHADED BOX INDICATES MAINTENANCE IS NOT NEEDED AT THIS TIME.									
		550 HRS	600 HRS	650 HRS	700 HRS	750 HRS	800 HRS	850 HRS	900 HRS	950 HRS	1000 HRS
Lubricate drum switches	See Section 5.5										
Grease pivot points and bearings/Oil chains	See Section 5.6										
Lubricate blade tensioner screw	See Section 5.6										
Check brake strap tension	See Section 5.8										
Check belt tensions	See Section 5.9 See Section 5.11										
Check feed & up/down chain tensions	See Section 5.11 See Section 5.12										
Check up/down & power feed gear box fluid levels	See Section 5.11 See Section 5.12										
Inspect hydraulic lines & fittings	See Section 5.10										
Check hydraulic fluid level	See Section 5.10										
Replace hydraulic system filter	See Section 5.10										
Inspect hydraulic pump, power feed and up/down motor brushes	See Section 5.10 See Section 5.11 See Section 5.12										

MAINTENANCE LOG

PROCEDURE	REFERENCE	TOTAL HOURS OF OPERATION									
		FILL IN THE DATE AND THE MACHINE HOURS AS YOU PERFORM EACH PROCEDURE. A SHADED BOX INDICATES MAINTENANCE IS NOT NEEDED AT THIS TIME.									
		1050 HRS	1100 HRS	1150 HRS	1200 HRS	1250 HRS	1300 HRS	1350 HRS	1400 HRS	1450 HRS	1500 HRS
Lubricate drum switches	See Section 5.5										
Grease pivot points and bearings/Oil chains	See Section 5.6										
Lubricate blade tensioner screw	See Section 5.6										
Check brake strap tension	See Section 5.8										
Check belt tensions	See Section 5.9 See Section 5.11										
Check feed & up/down chain tensions	See Section 5.11 See Section 5.12										
Check up/down & power feed gear box fluid levels	See Section 5.11 See Section 5.12										
Inspect hydraulic lines & fittings	See Section 5.10										
Check hydraulic fluid level	See Section 5.10										
Replace hydraulic system filter	See Section 5.10										
Inspect hydraulic pump, power feed and up/down motor brushes	See Section 5.10 See Section 5.11 See Section 5.12										

MAINTENANCE LOG

PROCEDURE	REFERENCE	TOTAL HOURS OF OPERATION									
		FILL IN THE DATE AND THE MACHINE HOURS AS YOU PERFORM EACH PROCEDURE. A SHADED BOX INDICATES MAINTENANCE IS NOT NEEDED AT THIS TIME.									
		1550 HRS	1600 HRS	1650 HRS	1700 HRS	1750 HRS	1800 HRS	1850 HRS	1900 HRS	1950 HRS	2000 HRS
Lubricate drum switches	See Section 5.5										
Grease pivot points and bearings/Oil chains	See Section 5.6										
Lubricate blade tensioner screw	See Section 5.6										
Check brake strap tension	See Section 5.8										
Check belt tensions	See Section 5.9 See Section 5.11										
Check feed & up/down chain tensions	See Section 5.11 See Section 5.12										
Check up/down & power feed gear box fluid levels	See Section 5.11 See Section 5.12										
Inspect hydraulic lines & fittings	See Section 5.10										
Check hydraulic fluid level	See Section 5.10										
Replace hydraulic system filter	See Section 5.10										
Inspect hydraulic pump, power feed and up/down motor brushes	See Section 5.10 See Section 5.11 See Section 5.12										

MAINTENANCE LOG

PROCEDURE	REFERENCE	TOTAL HOURS OF OPERATION									
		FILL IN THE DATE AND THE MACHINE HOURS AS YOU PERFORM EACH PROCEDURE. A SHADED BOX INDICATES MAINTENANCE IS NOT NEEDED AT THIS TIME.									
		2050 HRS	2100 HRS	2150 HRS	2200 HRS	2250 HRS	2300 HRS	2350 HRS	2400 HRS	2450 HRS	2500 HRS
Lubricate drum switches	See Section 5.5										
Grease pivot points and bearings/Oil chains	See Section 5.6										
Lubricate blade tensioner screw	See Section 5.6										
Check brake strap tension	See Section 5.8										
Check belt tensions	See Section 5.9 See Section 5.11										
Check feed & up/down chain tensions	See Section 5.11 See Section 5.12										
Check up/down & power feed gear box fluid levels	See Section 5.11 See Section 5.12										
Inspect hydraulic lines & fittings	See Section 5.10										
Check hydraulic fluid level	See Section 5.10										
Replace hydraulic system filter	See Section 5.10										
Inspect hydraulic pump, power feed and up/down motor brushes	See Section 5.10 See Section 5.11 See Section 5.12										

MAINTENANCE LOG

PROCEDURE	REFERENCE	TOTAL HOURS OF OPERATION									
		FILL IN THE DATE AND THE MACHINE HOURS AS YOU PERFORM EACH PROCEDURE. A SHADED BOX INDICATES MAINTENANCE IS NOT NEEDED AT THIS TIME.									
		2550 HRS	2600 HRS	2650 HRS	2700 HRS	2750 HRS	2800 HRS	2850 HRS	2900 HRS	2950 HRS	3000 HRS
Lubricate drum switches	See Section 5.5										
Grease pivot points and bearings/Oil chains	See Section 5.6										
Lubricate blade tensioner screw	See Section 5.6										
Check brake strap tension	See Section 5.8										
Check belt tensions	See Section 5.9 See Section 5.11										
Check feed & up/down chain tensions	See Section 5.11 See Section 5.12										
Check up/down & power feed gear box fluid levels	See Section 5.11 See Section 5.12										
Inspect hydraulic lines & fittings	See Section 5.10										
Check hydraulic fluid level	See Section 5.10										
Replace hydraulic system filter	See Section 5.10										
Inspect hydraulic pump, power feed and up/down motor brushes	See Section 5.10 See Section 5.11 See Section 5.12										

SECTION 6 TROUBLESHOOTING GUIDE

6.1 Sawing Problems

PROBLEM	CAUSE	SOLUTION
Blades Dull Quickly	Dirty logs	Clean or debark logs, especially on entry side of the cut
	When grinding teeth, heating too much and causing teeth to soften	Grind just enough metal to restore sharpness to the teeth. Use water/coolant while sharpening blade
	Poor sharpening techniques	Make sure the tip is being sharpened completely (See Sharpener Manual)
Blades Break Prematurely	Poor sharpening techniques	See Sharpener Manual
	Tension too tight	Tension blade to recommended specifications
Blade Does Not Track Right on Drive Wheel	Cant adjustment is incorrect	Readjust
Drive Belts Wear Prematurely or Jump	Engine/motor and drive pulleys out of alignment	Align pulleys See Section 7.6.

PROBLEM	CAUSE	SOLUTION
Boards Thick Or Thin On Ends Or Middle Of Board.	Stress in log which causes log to not lay flat on the bed.	After log has been squared, take equal cuts off opposing sides. Take a board off the top. Turn the log 180 degrees. Take a board off. Repeat, keeping the heart in the middle of the cant, and making it your last cut.
		Use front and rear log clamps. See Section 4.2
	Set in teeth.	Resharpener and reset blade.
	Bed rails misaligned.	Realign sawmill.
Height Adjustment Jumps or Stutters When Moving Up or Down.	Up/down chain improperly adjusted.	Adjust up/down chain.
	Up/down belt loose.	Replace belt.
Lumber Is Not Square	Vertical side supports not square to bed	Adjust side supports.
	Blade not parallel to bed rails	Adjust bed rails parallel to blade.
	Sawdust or bark between cant and bed rails	Remove particles
	Tooth set problems	Resharpener and reset blade
Sawdust Builds Up On Track	Excessive oiling	Do not oil track
	Track wipers worn	Adjust wipers to firmly contact track
	Track is sticky	Clean track with solvent and apply silicone spray
Wavy Cuts	Excessive feed	Slow feed rate
	Improperly sharpened blade (This will be the problem 99% of the time!)	Resharpener blade (See Sharpener Manual - read entire manual!)
	Blade guides improperly adjusted	Adjust blade guides.
	Sap buildup on blade	Use Water Lube.
	Tooth set problem	Resharpener and reset blade

6.2 Electrical Problems

PROBLEM	CAUSE	SOLUTION
Up/down Excessively Slow.	Up/down belt loose.	Adjust belt to be as loose as possible without slipping.
	Worn up/down motor or motor brushes.	Replace up/down motor or motor brushes.
Up/down Or Power Feed Motors Do Not Work.	Worn/dirty contacts in drum switch.	Replace switch or remove control panel cover and clean contacts.
	Bad key switch.	Replace key switch.
	Circuit breaker.	Reset breaker in control box (See Section 6.9).
Power Feed Motor Does Not Work.	Burned-out motor.	Replace motor.
	Bad connection on battery post or loose wire.	Check for loose wire or terminal connections.
Power Feed Motor Does Not Work.	Sawdust buildup in the power feed pulleys.	Sawdust buildup puts mechanical bind on power feed which causes automatic motor protection circuit to activate. Remove sawdust from pulleys and operate normally. If motor does not operate after sawdust removal, reset circuit breaker on the front of the control box.
Up/Down Or Power Feed Switches Remain Engaged When Switch Is Released.	Worn or dirty contacts in drum switch.	Manually move the power feed or up/down switch back to neutral or "off" position. Replace drum switch or remove control panel cover and clean and lubricate contacts NOTE: Use only contact grease supplied by Wood-Mizer.
	Drum switch spring broken.	Manually move the power feed or up/down switch back to neutral or "off" position. Replace drum switch spring.

PROBLEM	CAUSE	SOLUTION
Up/Down Or Power Feed Motors Overheat And Lose Power.	System overload or bind occurred.	Correct problem (See Section 6.3). Allow motor to cool before restarting.
	Normal operation factors exceeded (eg: up/down control jockeyed excessively).	Allow motor to cool before restarting.
Everything Works And Then Cuts Out - Works Again.	Bad battery, fuse, or ground connection.	Check and tighten connections.
Nothing Works Electrically.	Dead battery.	Check for short circuit or turn OFF key.
	Blown fuse.	Replace.
	Corrosion on battery post.	Remove connection and clean posts.
	Loose connections at LED circuit board or alternator.	Check and tighten connections.
Intermittent Or Permanent Loss Of Accessory Motor Functions Occurs (Up/down, Fwd/rev, Blade Guide Functions Do Not Work).	Bad connections at accessory solenoid or bad solenoid.	Check all connections at accessory solenoid. If connections are good, replace solenoid.

6.3 Power Feed Problems

NOTE: The power feed circuit board is equipped with LED lights to help determine if the circuit board or feed rate switch are the cause of any feed problems you may encounter. [See Section 6.4](#) for instructions.

PROBLEM	CAUSE	SOLUTION
Power Feed Is Jerky At Low Speeds Or Does Not Move Until Speed Is Above Halfway Mark.	Drum switch is dirty.	Clean drum switch and lubricate with contact grease supplied by Wood-Mizer.
	Drum switch contacts are bad	Check that contacts are in good condition and positively close circuit.
Power Feed Is Jerky When Shaft Of Feed Rate Dial Is Moved Back And Forth.	Components are loose or wires are broken.	Replace or repair PC board.
	Variable speed switch is bad - perform the variable speed switch test.	Replace variable speed switch.
Power Feed Is Jerky, But Power Feed Motor Runs Properly At All Speeds.	Problem is mechanical.	Refer to the Mechanical Test.

PROBLEM	CAUSE	SOLUTION
Power Feed Motor Overheats.	Middle track oiler is dragging.	Clean and lubricate the middle track oiler. Allow motor to cool before restarting.
	Ground is not level.	Level the sawmill. Allow motor to cool before restarting.
	Track roller bearing drag is excessive.	Replace the roller. Allow motor to cool before restarting.
	Chain is dragging.	Make sure chain is centered on idler; Clean and lubricate chain; Adjust chain tension. Allow motor to cool before restarting.
	Chain is improperly tensioned.	Adjust chain tension. Allow motor to cool before restarting.
	Operator Seat option load is excessive.	Check seat bearings for freedom of movement; Loosen clamping screw 1/4 turn. Allow motor to cool before restarting.
	Power feed is binding.	Adjust belt tension; Check condition of belt, pulleys, bearings, and sprocket; Check motor for ground fault. Allow motor to cool before restarting.
	Saw head load is excessive.	Avoid unnecessary modifications to saw heads that would give them extra weight. Allow motor to cool before restarting.
Blade is dull or improperly set.	Use proper blade maintenance procedures (See Sharpener or Toothsetter manual). Allow motor to cool before restarting.	

6.4 Power Feed Circuit Troubleshooting

LED lights are provided on the control module to help troubleshoot any feed problems you may encounter.

See Figure 6-1. The lights can be viewed by removing the rear control box panel.

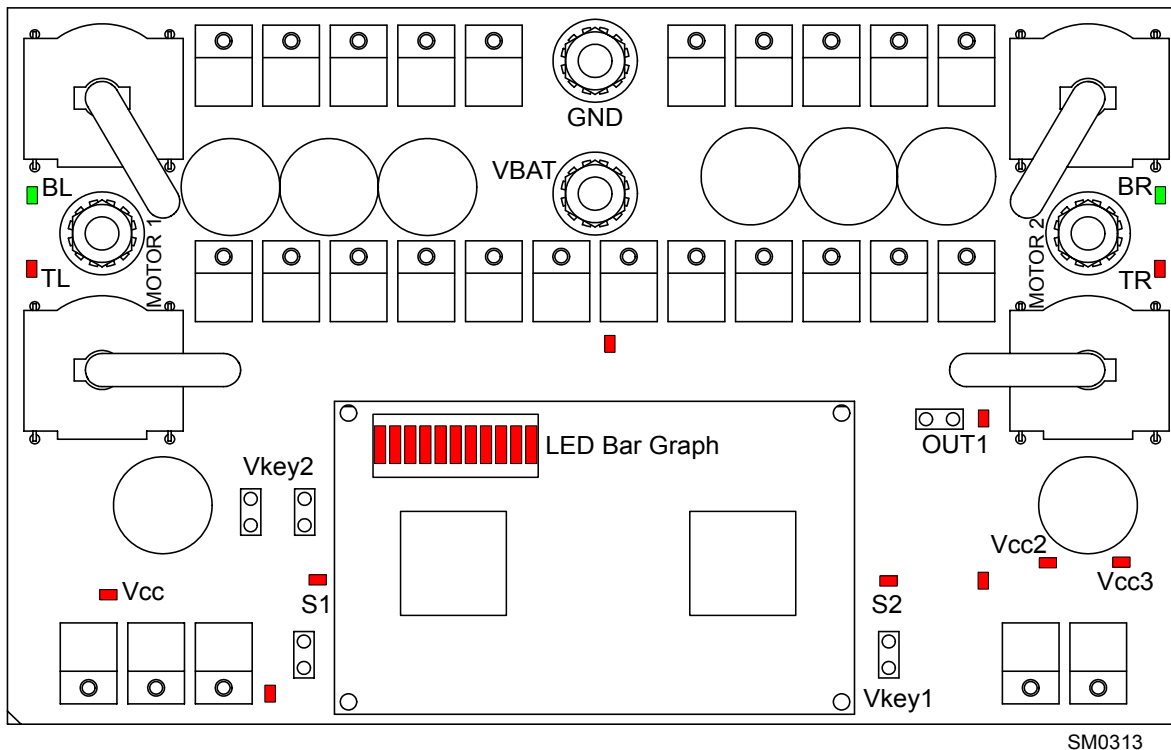

FIG. 6-1

If you have trouble determining the problem indicated by the lights, please note which lights are on and call customer service for assistance.

BL, TL, BR, TR - The two red and two green lights indicate different states of sawmill operation. Several different states of the lights in three positions of the power feed drum switch with the feed rate dial switch all the way up are shown below.

See Table 6-1. The drum switch positions and light states with the feed rate dial switch all the way up are shown below.

Power Feed Drum Switch Position	BL	TL	BR	TR
FORWARD	On	Off	Off	On
REVERSE	Off	On	On	Off
NEUTRAL	On	Off	On	Off

TABLE 6-1

Please contact Customer Service for assistance if necessary when troubleshooting the system using these lights.

S1, S2 - These two red lights indicate the position of the power feed drum switch. Three possible positions are shown in table below. If the lights are not on or off as shown, the power feed drum switch is probably miswired or defective.

See Table 6-2. The light states and drum switch positions are shown below.

Power Feed Drum Switch Position	S1	S2
FORWARD	On	Off
REVERSE	Off	On
NEUTRAL	On	On

TABLE 6-2

OUT1 - This red light is on when power is applied to the accessory solenoid. When the OUT1 is off, the accessory solenoid is not powered. Check the jumper cable connecting Vkey1 and Vkey2 Terminals. Reconnect if necessary. If the light is still off the accessory solenoid may be defective.

Vcc - The Vcc light is on when power is applied to the Vkey2 Terminal. If the light is off, check all connections to the key switch. Also check the fuse located between the Vkey2 terminal and the key switch. Check the 225 Amp fuse in the fuse box. Make sure the battery connections are correct.

Vcc2 - This red light indicates that power is applied at the control circuits from the key switch. The light is off when the Vcc light is off. Refer to the Vcc light problems when troubleshooting this light.

Vcc3 - This red light is on indicating the power feed control circuits. The light is off when the Vcc and Vcc2 are off. Refer to the Vcc light to solve potential problems.

The LED Bar Graph located on the power feed board can also be used to troubleshoot feed problems. Check below for different codes on the LED Bar Graph to find the problem.

See Figure 6-2. The operational codes of the LED Bar Graph are shown below.

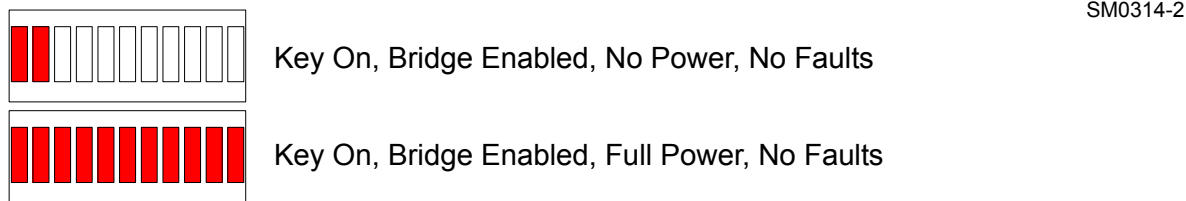

FIG. 6-2

See Figure 6-3. The LED Bar Graph problem codes are shown below.

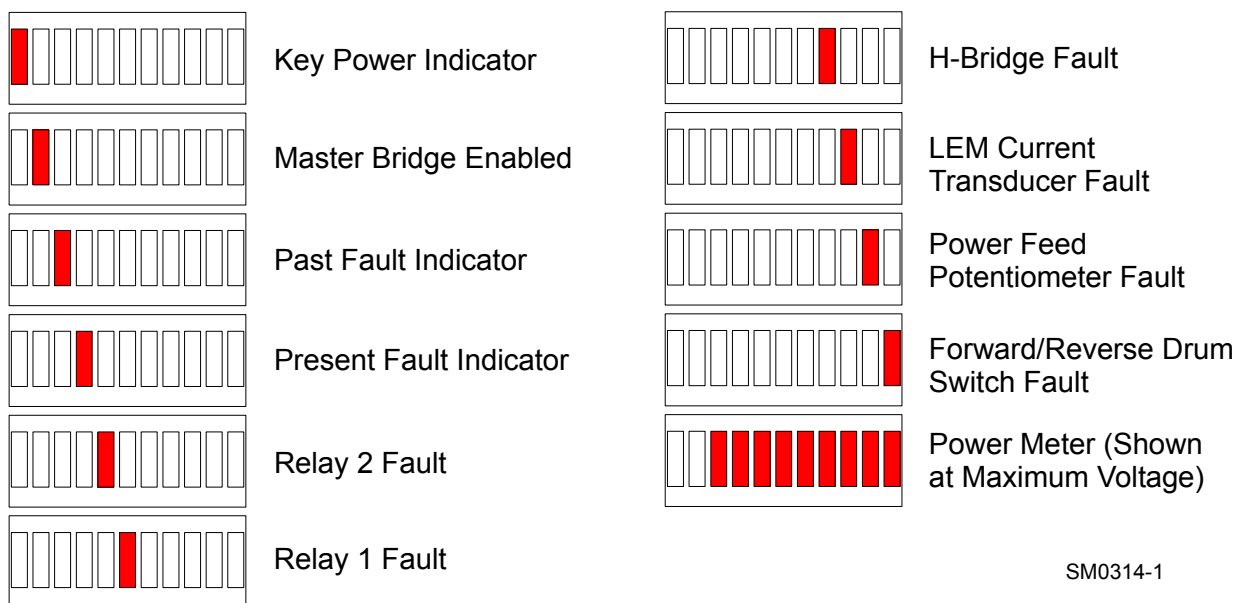

FIG. 6-3

When troubleshooting the system, please note which LED Bar Graph lights are on and contact Customer Service for assistance.

6.5 Hydraulic Problems

PROBLEM	CAUSE	SOLUTION
<p>You Can Actuate Any Hydraulic Handle, But Get No Response From The Pump.</p>	Carriage not positioned properly to provide power to the pump	Make sure carriage contact bracket is adjusted far enough forward for battery positive contact to touch 6ft. strip on main tube. Check contact and strip for tarnish or loose wires. Clean as necessary
	Poor ground connection	Check ground connection between pump and saw frame and between battery negative contact and lower rail. Check contact and rail for tarnish or loose wires. Clean as necessary
	Blown fuse	Replace
	Low or dead battery	Test battery amperage capability (such as low battery charge, low alternator output, defective voltage regulator, bad battery cell, battery age deterioration, etc.). Replace or recharge as necessary
	Defective pump motor	Remove motor from pump and inspect. Repair or replace as necessary
	Poor cable connection	Check cable connection and make sure that battery terminals are in good condition (not corroded)
	Defective solenoid (may be indicated by solenoid clicking) See Monarch manual for troubleshooting solenoid	After checking all other possibilities for low voltage to solenoid, check solenoid. Tapping on solenoid may fix temporarily. Replace solenoid if necessary. NOTE: The solenoid is not a standard automotive type. Order from Wood-Mizer only

PROBLEM	CAUSE	SOLUTION
You Can Get Response From the Pump By Actuating All But One or Two Handles	Valve assembly switch contacts are not properly adjusted	Locate the valve switch at the bottom of the valve assembly. Use a 3MM allen wrench to loosen the set screw on each of the five switch contacts. Press each contact to the valve block and tighten the contact set screw to secure in place. CAUTION! Do not overtighten! NOTE: Do not adjust the valve switch or switch spring; they have been preset at the factory.

PROBLEM	CAUSE	SOLUTION
Pump Motor Runs With Little Or No Response From The Cylinders	Low battery	Test battery. Recharge or replace as necessary
	Low fluid level	Check fluid level. Add an all-season hydraulic fluid such as Amoco Rycon Oil MV or Mobil Multipurpose ATF (automatic transmission fluid) until level is 4 - 4 1/2" from bottom of reservoir with all cylinders retracted
	Pressure relief valve moved from proper setting	Adjust pressure relief valve.
	Low air temperature causing fluid to thicken	Allow fluid to warm up. Synthetic fluids are available that allow for hydraulic operation in cold weather conditions (Mobil SHC 526)
Pump Motor Runs Continuously When Power Contact Is Made	Solenoid is stuck closed	Tapping the solenoid may solve this problem temporarily. Replace solenoid
Fluid Leaks From Around Cylinder Piston Ram	Worn seals	Replace seals in cylinder. Check piston ram for abrasive weld that may be causing premature seal failure
Fluid Leak Around Pump Box	Loose seal or fitting	Wipe pump off completely to locate cause of leak. You may have to unbolt the pump to wipe behind it. NOTE: Movement of the sawmill can cause fluid to slosh up into the foam filter in the reservoir cap, and subsequently spray out, giving the appearance that fluid is leaking from the pump

PROBLEM	CAUSE	SOLUTION
Hydraulic Side Supports Go Down Before Or At Same Time As Log Turner	Dirt in sequence valve	Remove sequence valves and clean thoroughly with kerosene. NOTE: Be sure to reassemble the valve and install it in its original position on the cylinder
	Retainer in sequence valve worn	Replace sequence valve
	Low air temperature causing fluid to thicken	Allow fluid to warm up. Synthetic fluids are available that allow for hydraulic operation in cold weather conditions (Mobil SHC 526)
Hydraulic Turner Goes Up Before Or At Same Time As Side Supports	Spring weakening in sequence valve	Locate sequence valve at top of turner cylinder. Turn heavy spring in about 1/4 turn
	Dirt in sequence valve	Remove sequence valves and clean thoroughly with kerosene. NOTE: Be sure to reassemble the valve and install it in its original position on the cylinder
	Retainer in sequence valve worn	Replace sequence valve
	Low air temperature causing fluid to thicken	Allow fluid to warm up. Synthetic fluids are available that allow for hydraulic operation in cold weather conditions. (Mobil SHC 526)
	Springs weakening in sequence valve.	Locate sequence valve at bottom of turner cylinder. Turn heavy spring in about 1/4 turn

Hydraulic Toe Boards or Clamp "Creep" DOWN without the valve control handles being operated OR do not raise or lower at all.

Can be a result of failing to lower completely the toe board/log clamp before loading the log and hitting the toe board/log clamp by the log being loaded (which can cause damage to the toe board/log clamp and the sawmill bed).

- Damaged hoses;
- Damaged cylinder seals or cylinder;
- Damaged valve.

INITIAL CHECK

To check, disconnect the toe board hydraulic hose from its current valve section and temporarily connect it to another valve section. Check to see if the hydraulics operate properly.

If hydraulics operate properly, hoses and cylinder seals are good. Perform further valve inspection, found below.

If down creep still occurs, check all hoses for possible pinholes causing leakage. Replace if applicable. Retest. **If down creep still occurs**, replace cylinder seals or cylinder and retest.

Be sure to reconnect the hose to the proper valve section when done.

FURTHER VALVE INSPECTION

If further inspection of the valve is required after initial check, remove the check valve shown below. Flush the check valve with an air hose or solvent to remove any dirt from the valve's seat. Reinstall and test again. Check to see if the hydraulics operate properly.

If down creep still occurs, replace the check valve with a new one. Retest. **If down creep still occurs**, replace the hydraulic valve section.

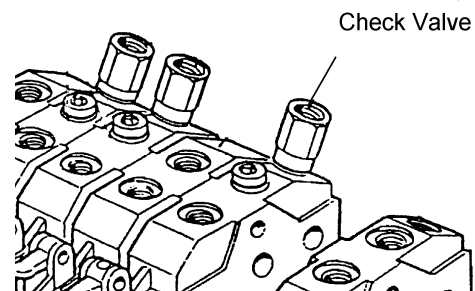

Bad check valve (results in one of the toe boards experiencing down-creep).

Replace the hydraulic valve section.

6.6 Engine/Motor and Drive Pulleys Alignment

1. Install the drive belt.
2. Use a straight edge to align the engine/motor pulley to the drive pulley. Also check that the engine pulley is within 1/8" square with the drive pulley. Loosen the engine mounting bolts and rotate the engine if necessary.
3. Check front-to-back movement of the engine does not exceed 1/4". Tighten the motor mount U-bolts if necessary.
4. Engage the clutch handle and adjust the drive belt tension to 7/16" deflection with 10 lb. of force.
5. Recheck the pulley alignment and engine squareness with the clutch handle engaged. Adjust if necessary.
6. Adjust the drive belt support to 1/4" ($\pm 1/32$) from the belt while engaged.

6.7 Power Feed Variable Feed Rate Switch Test

With the feed rate dial switch all the way down, move the shaft of the dial back and forth to see if there is a jerky response. Turn the dial and move the shaft back and forth again. Repeat several times. If the jerkiness occurs at the same location on the dial several times, you need to replace the variable speed switch.

6.8 Power Feed Preliminary Test

This test will determine if the problem is a mechanical or electrical.

1. Remove the drive belt from the power feed drive pulley.
2. Turn the key switch to the ACC position. Put the carriage forward/reverse switch into the forward position and turn the feed rate dial through all speeds. If the power feed motor runs properly at all speeds, the problem is a mechanical one instead of an electrical one.

6.9 Power Feed Mechanical Test

1. Remove the weight from the track rollers. They should turn smoothly and easily with very little play.
2. Make sure the middle track cover is not bent or touching the top rail.
3. Make sure the middle track oiler is free of sawdust buildup.
4. Make sure the power feed chain is not stiff from rust. Also make sure the chain is not too tight.
5. Check the power feed shaft. Visually inspect the bearings. The shaft should move neither in or out nor side to side.

6. Make sure there is no sap or rust on the rails.

6.10 Fuse Terminal Extension Stud

A fuse terminal extension stud is provided in the fuse box. The extension may be used to temporarily connect a battery charger or jumper cables to raise the saw head from the towing position so the battery box lid can be removed.



CAUTION! The fuse stud extension is designed to provide enough power to raise the saw head only. Do not attempt to start the engine or operate any other electrical function until direct battery charging can be performed. Do not attempt to move the saw head by attaching jumper cables from a secondary power source to the up/down motor terminals. Damage to the electrical system will result.

See Figure 6-4.

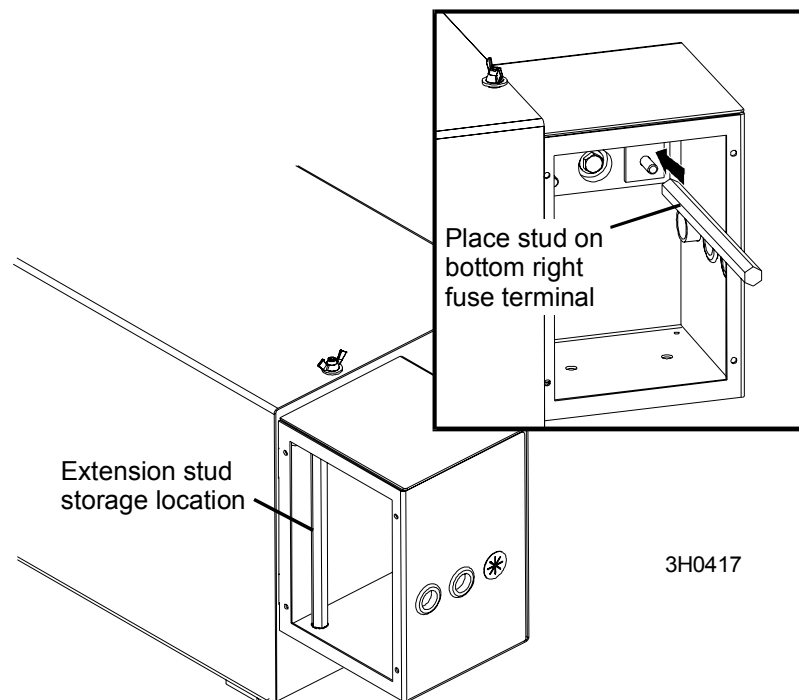

FIG. 6-4

1. Remove the fuse box cover and remove the stud from its storage position inside the fuse box.
2. Thread the extension stud on the bottom-right fuse terminal.
3. Attach the positive cable from a battery charger or jumper cables to the extension stud.

4. Connect the negative cable from the charger or jumper cables to a grounded metal surface. The mounting bolts on the bottom of the control box are an acceptable ground.
5. Charge or jump the battery until it can supply enough power to raise the saw head.
6. After the saw head is raised, remove the negative cable from ground.
7. Remove the positive cable from the extension stud.
8. Remove the extension stud from the fuse terminal and return it to its storage location.
9. Remove the battery box lid and connect the positive cable directly to the positive battery terminal.
10. Connect the negative cable to a grounded metal surface.
11. After the battery is completely recharged, remove the negative charger cable from ground. Remove the positive cable from the battery and replace the battery box lid.

6.11 Circuit Breaker Operation

Sawmill controls are equipped with manual reset circuit breakers to protect the electrical circuits.

See Figure 6-5. The power feed and up/down breakers are externally mounted at the front of the control box. The blade guide, accessory, ignition, start, and board return breakers are located inside the control box. Remove the circuit breaker panel from the control box to access the internal breakers.

NOTE: If the breaker is still hot, you may not be able to reset it immediately. Allow the breaker to cool for a few minutes before attempting to reset.

SECTION 7 SAWMILL ALIGNMENT

The Wood-Mizer sawmill is factory aligned. Two alignment procedures are available to realign the sawmill if necessary. The Routine Alignment instructions should be performed as necessary to solve sawing problems not related to blade performance. The Complete Alignment procedure should be performed approximately every 1500 hours of operation (sooner if you regularly transport the sawmill over rough terrain).

7.1 Routine Alignment Procedure

Blade Installation

1. Remove the blade and check the blade wheels. Remove any sawdust buildup from the surface of the wheels.
2. Install a clean blade and apply the appropriate tension ([See Section 3.4](#)).
3. Check the ceramic blade guide inserts and drive side deflector plate are properly adjusted ([See Section 5.2](#)).
4. Adjust the idle-side cant control to track the blade ([See Section 3.5](#)).
5. Close the blade housing covers and make sure all persons are clear of the saw head.
6. Turn the key switch to #3 position.
7. Engage the blade switch.
8. Manually spin one of the blade wheels until the blade positions itself on the blade wheels.



Saw Head Tilt

As the blade enters a wide log or cant, the outside of the saw head will drop down slightly. To compensate for the drop, the saw head is adjusted 1/26" (1 mm) higher at the outside.

1. Move the saw carriage so the blade is positioned over a bed rail. Adjust the blade guide arm to 1/2" (15 mm) from full open.
2. Raise the saw head so the bottom of the blade measures 14 3/4" (375 mm) from the top surface of the bed rail near the inner blade guide assembly.

See Figure 7-1.

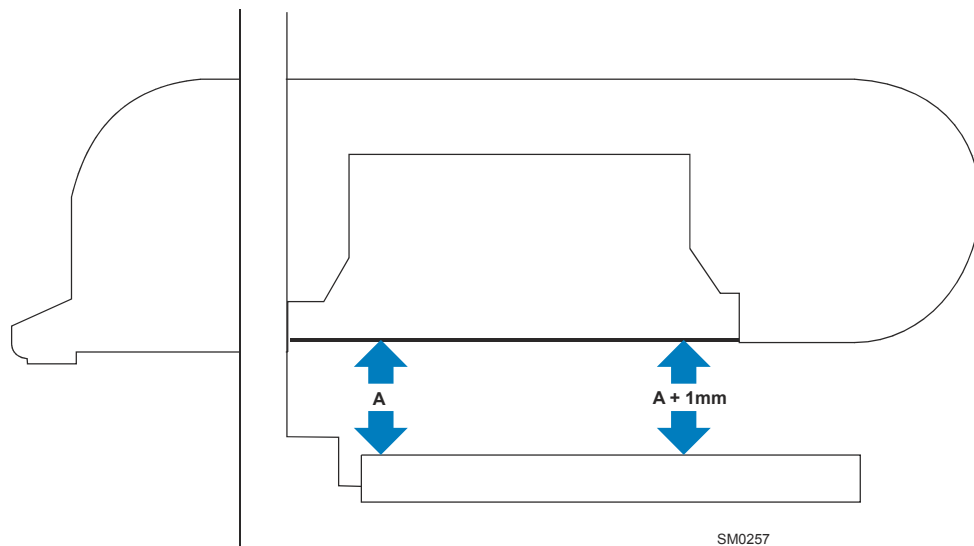

FIG. 7-1

3. Measure from the blade to the bed rail near the outer blade guide assembly. This measurement should be 1/26" (1 mm) higher than the inner measurement or 14 13/16" (376mm).

See Figure 7-2. To adjust the saw head tilt, use the bolts located at the bottom of the saw head mast. Loosen the three sets of four retaining plate bolts. To raise the outside of the saw head, back the stop bolts out, then tighten the adjustment bolts. To lower the outside of the saw head, loosen the adjustment bolts and tighten the stop bolts. Recheck the measurement from the blade to the bed rails and adjust the stop bolts and adjustment bolts until the outside of the saw head is 1/26" (1mm) higher than the inside. Retighten the retaining plate bolts.

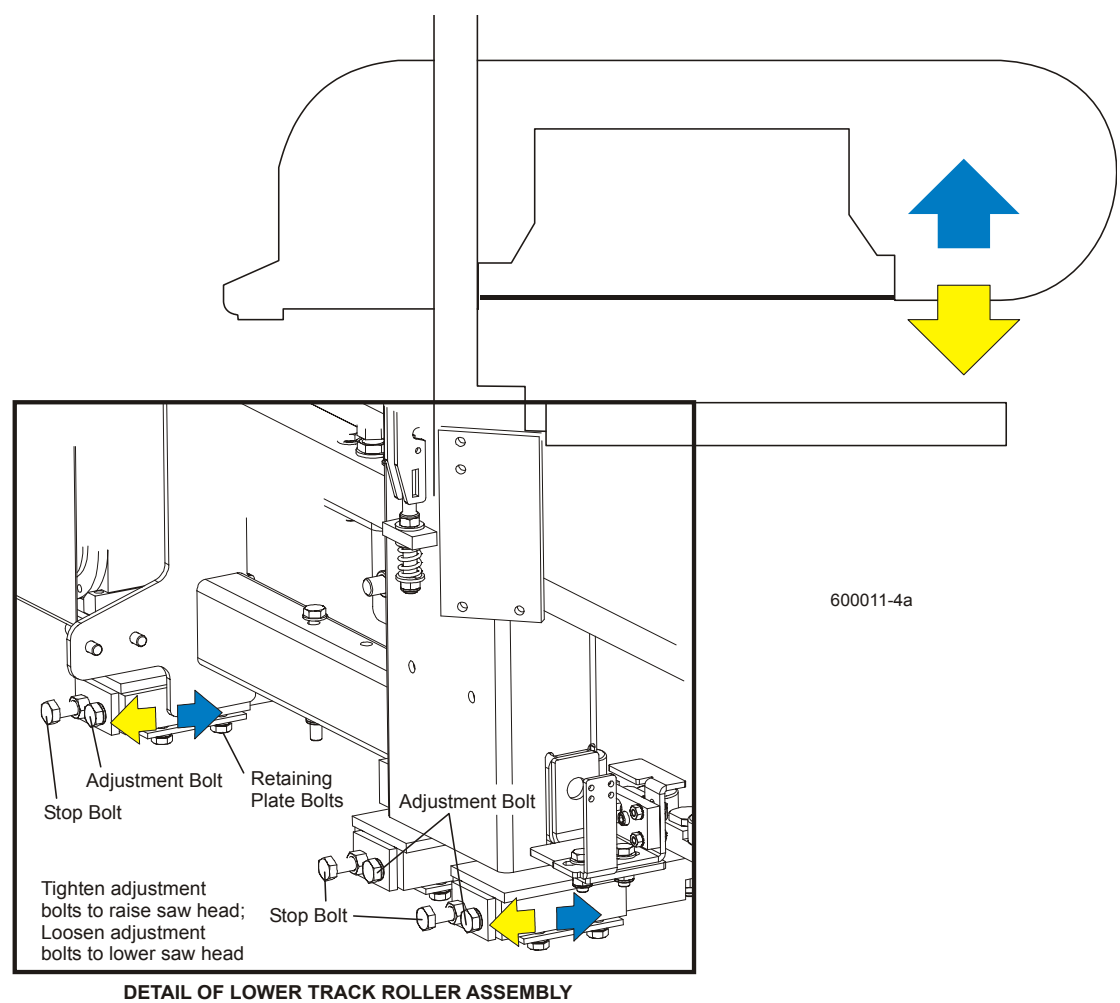

FIG. 7-2

Blade Guide Arm Alignment

The blade guide arm moves the outer blade guide in and out. If the arm becomes loose, the blade guide will not deflect the blade properly, causing inaccurate cuts. A loose blade guide arm can also cause blade vibration.

1. Adjust the blade guide arm in to 1/2" (15 mm) from fully closed.
2. Manually try to move the arm up and down. If you can move the arm by hand, you will need to tighten the arm rollers.

See Figure 7-3. Loosen the jam nuts and turn the adjustment bolts in to tighten the blade guide arm rollers. Retighten the jam nuts.

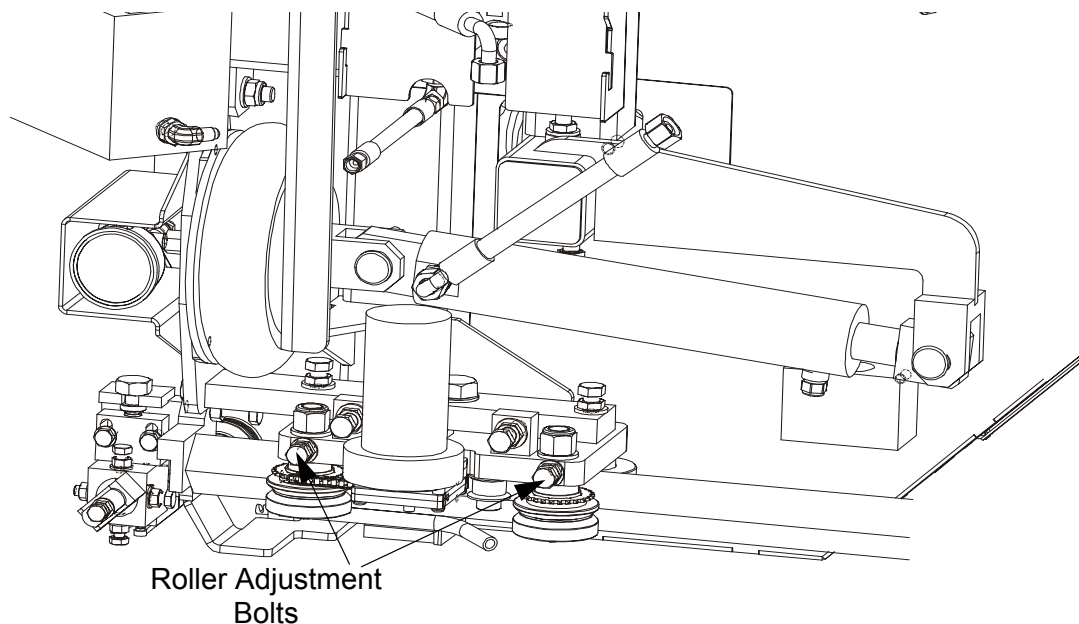

FIG. 7-3

After tightening the blade guide arm rollers, check that the arm is aligned properly.

Blade Guides

3. With the arm adjusted 1/2" (15 mm) from fully closed, measure the distance between the blade guide roller flange and the back of the blade. If the sawmill is equipped with optional all-ceramic guides, measure from the back of the blade to the back roller.

See Figure 7-4.

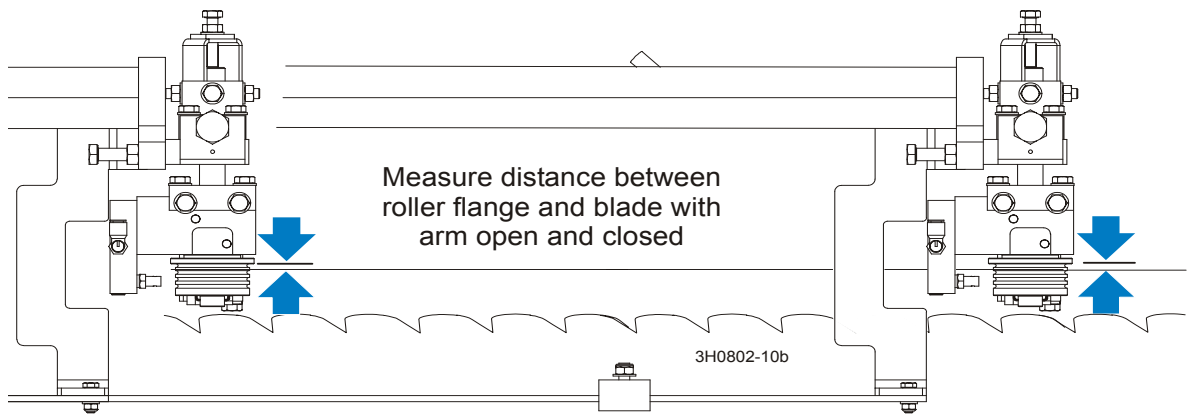

FIG. 7-4

- Adjust the blade guide arm to 1/2" (15 mm) from fully open and remeasure the distance from the roller flange to the back of the blade. The two measurements should be the same. If not, adjust the outer rollers in or out to tilt the arm horizontally.

See Figure 7-5. Loosen the horizontal adjustment bolt jam nuts. To tilt the arm in toward the blade, loosen the right bolt and tighten the left bolt. To tilt the arm out away from the blade, loosen the left bolt and tighten the right bolt. Retighten the jam nuts and recheck the blade guide arm horizontal tilt.

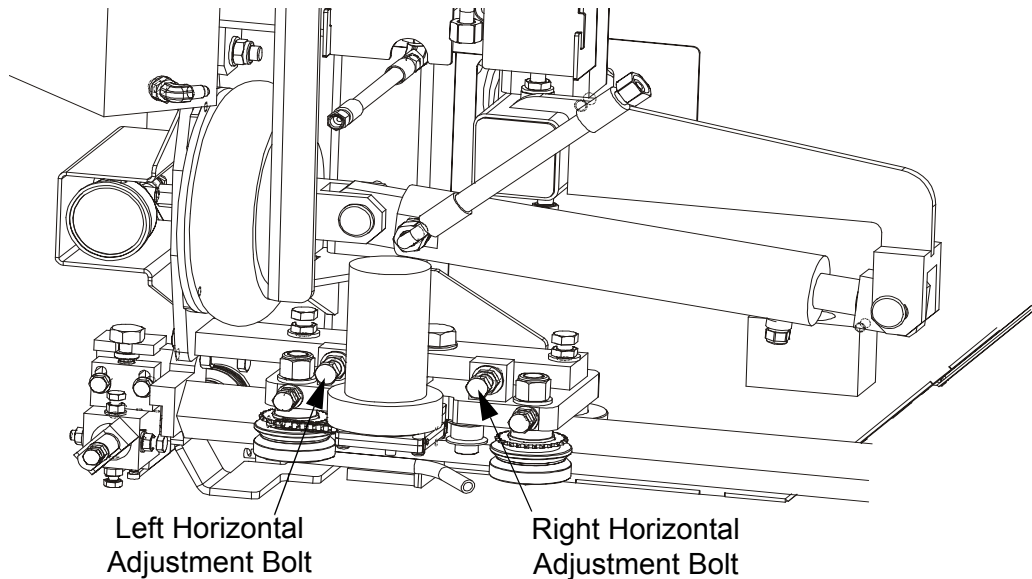

FIG. 7-5

- Now check the vertical tilt of the blade guide arm. Move the saw carriage so the blade guide arm is positioned over a bed rail.
- With the arm 1/2" (15 mm) from fully closed, raise or lower the saw head until the bottom of the blade guide block is 15" (375 mm) from the top of the bed rail.

See Figure 7-6.

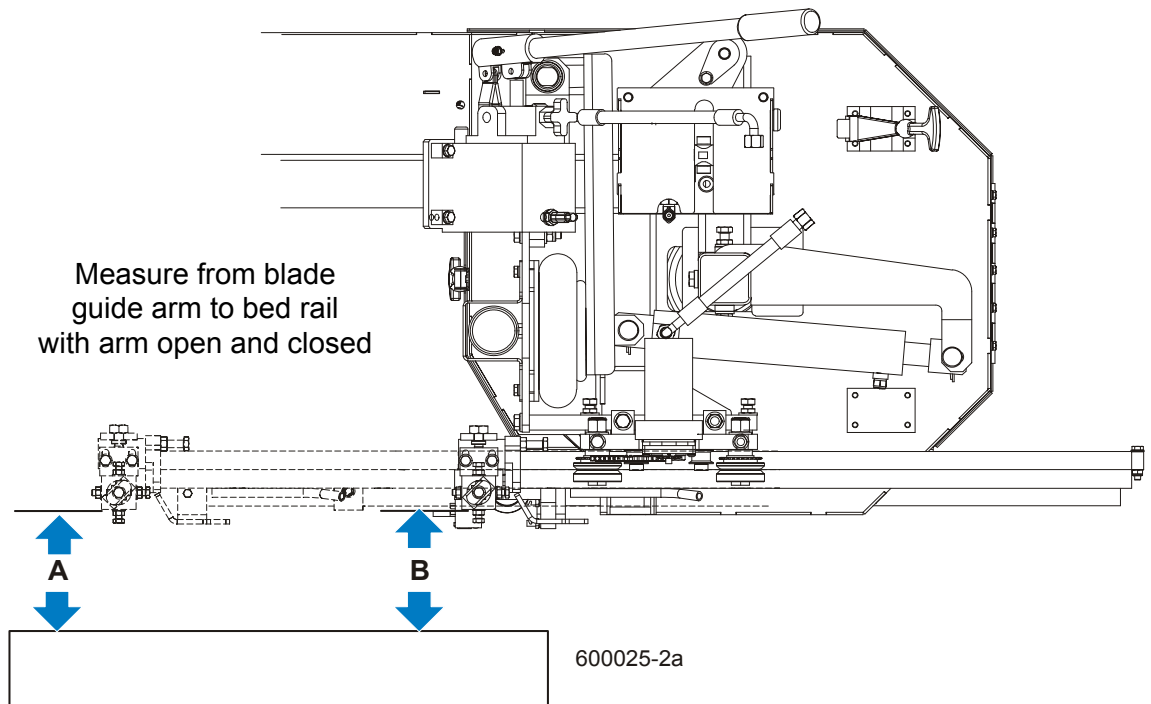

FIG. 7-6

7. Adjust the blade guide arm to 1/2" (15 mm) from fully open. Measure the distance from the bottom of the blade guide mounting block to the bed rail. This measurement should be 15" (375 mm) or slightly higher because the saw head is tilted up 1/26" (1 mm) on the outside ([See Saw Head Tilt](#)). If the blade guide is closer to the bed rail or more than 1/26" (1mm) higher with the arm open, adjust the blade guide arm vertically.

See Figure 7-7. Loosen the vertical adjustment bolt jam nuts. To tilt the blade guide arm down, loosen the right bolt and tighten the left bolt. To tilt the blade guide arm up, loosen the left bolt and tighten the right bolt. Retighten the jam nuts and recheck the blade guide arm vertical tilt.

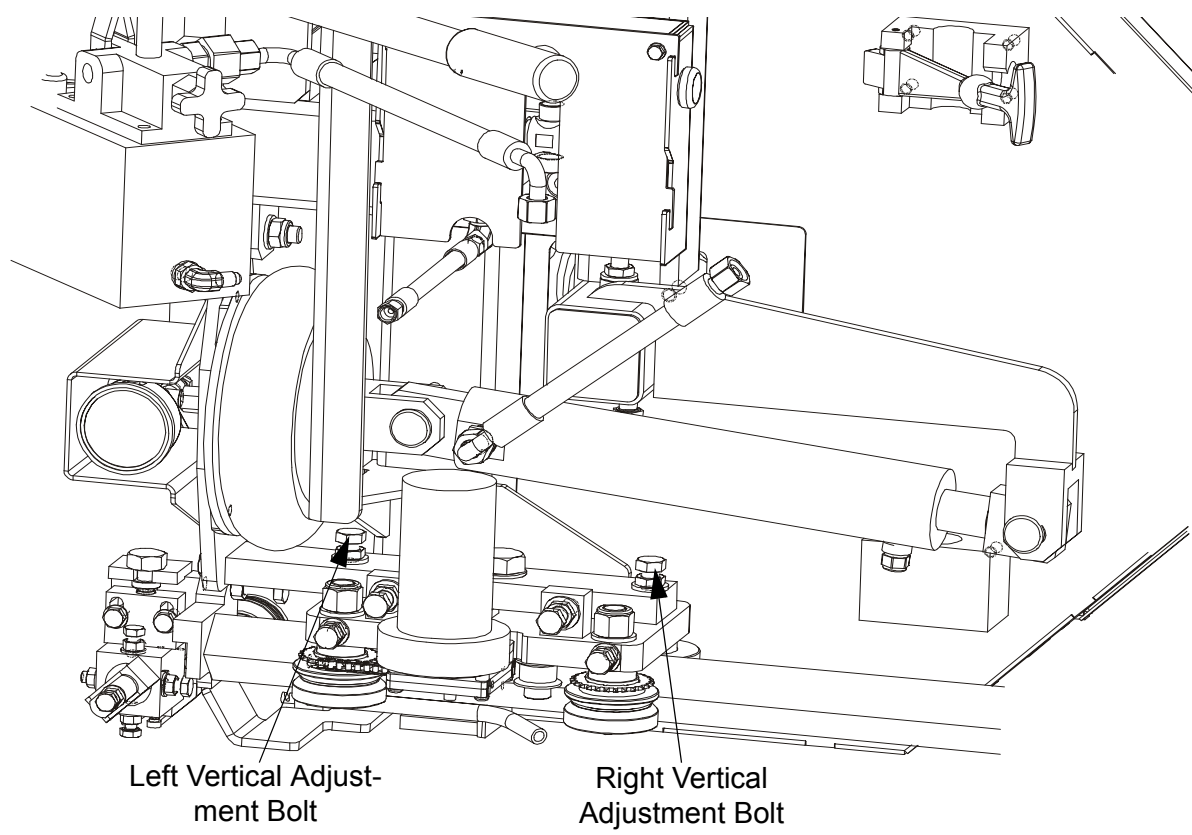

FIG. 7-7

Blade Guide Vertical Tilt Alignment

The blade guides should be adjusted properly in the vertical plane. If the blade guides are tilted vertically, the blade will try to travel in the tilted direction.

A Blade Guide Alignment Tool (BGAT) is provided to help you measure the vertical tilt of the blade.

1. Open the adjustable blade guide arm 1/2" (15 mm) from full open.
2. Clip the alignment tool on the blade. Position the tool close to the outer blade guide assembly. Be sure the tool does not rest on a tooth or burr, and is lying flat against the bottom of the blade.

See Figure 7-8.

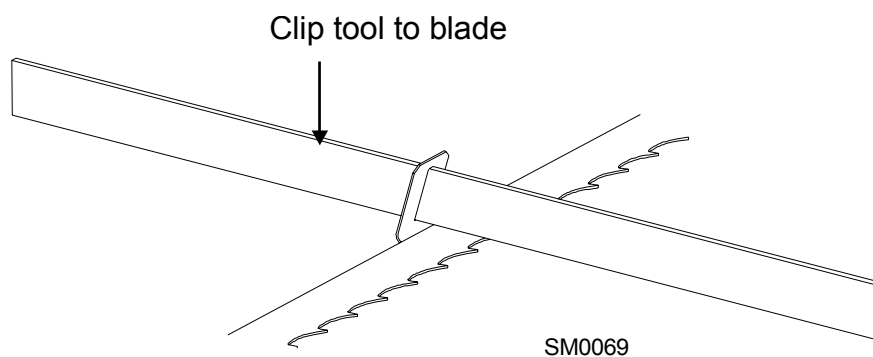

FIG. 7-8

3. Move the carriage so that the front end of the tool is positioned above the bed rail. Measure the distance from the bed rail to the bottom edge of the tool.
4. Move the carriage so that the back end of the tool is positioned above the bed rail. Measure the distance from the bed rail to the bottom edge of the tool.
5. If the measurement from the tool to the bed rail is not equal within 1/26" (1 mm), adjust the vertical tilt of the outer blade guide roller.

See Figure 7-9. Loosen the jam nuts on the top and bottom vertical tilt adjustment screws. To tilt the

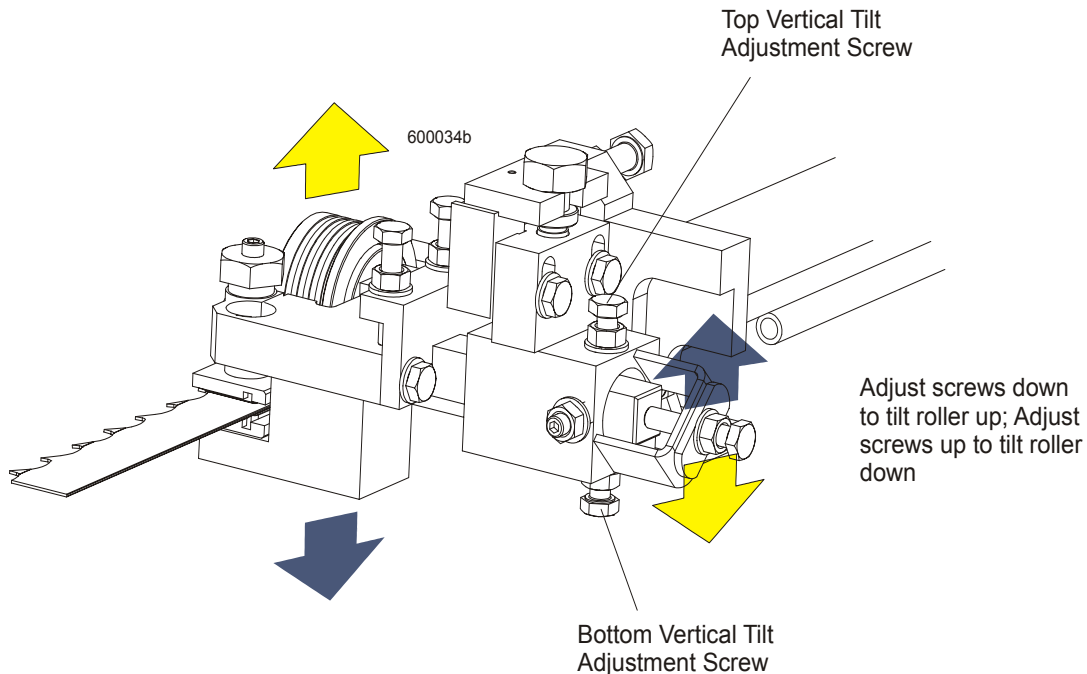

FIG. 7-9

roller up, loosen the bottom screw and tighten top screw. To tilt the roller down, loosen the top screw and tighten the bottom screw. Tighten the jam nuts and recheck the tilt of the blade.

6. Move the blade guide alignment tool close to the inner blade guide roller assembly and repeat the above steps. Adjust the vertical tilt of the inner blade guide if necessary.

Blade Guide Horizontal Tilt Adjustment

If the blade guides are tilted in the wrong direction horizontally, the back of the blade may contact the flange as the roller is spinning down, causing it to push the blade away from the guide roller.

1. Remove the blade guide alignment tool from the blade and adjust the blade guide arm halfway in.
2. Remove the clip from the blade guide alignment tool. Place the tool against the face of the outer blade guide roller.

See Figure 7-10.

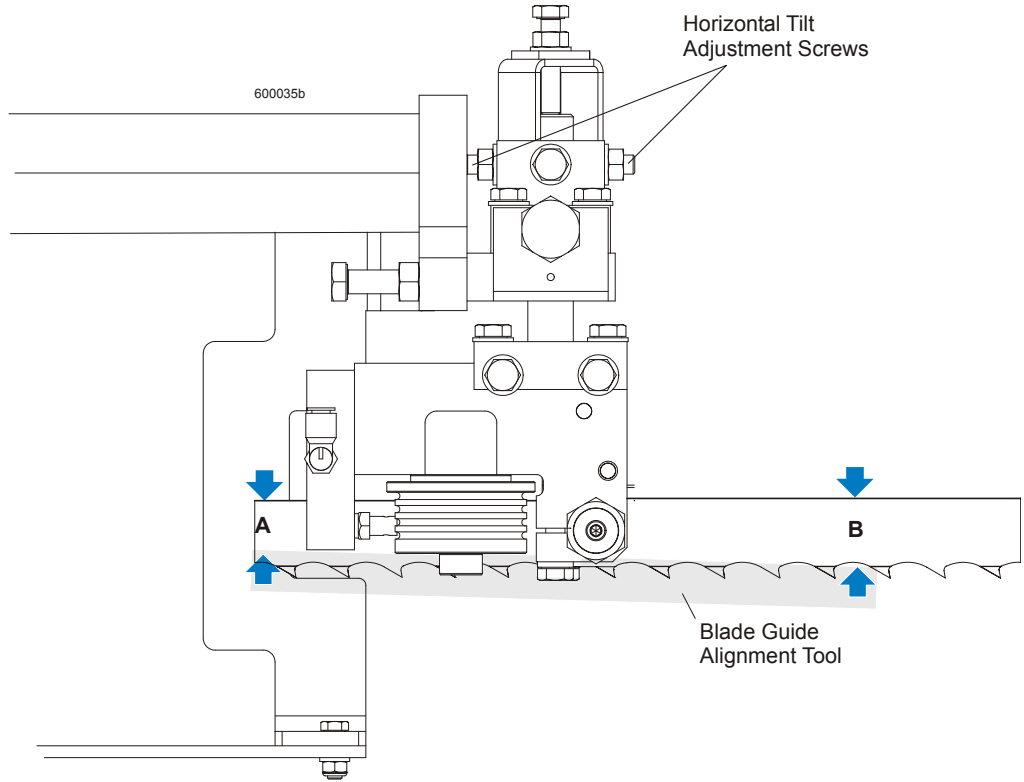

FIG. 7-10

3. Measure between the back edge of the blade and the tool at the end closest to the inner blade guide ("B").
4. Measure between the back edge of the blade and the other end of the tool ("A").

The roller should be tilted slightly to the left ('A' 1/8" [3 mm] less than 'B' ±1/8" [3 mm]).

See Figure 7-11. Loosen the jam nuts on the horizontal tilt adjustment screws. To tilt the roller left, loosen the right screw and tighten left screw. To tilt the roller right, loosen the left screw and tighten the right screw. Tighten the jam nuts and recheck the tilt of the blade.

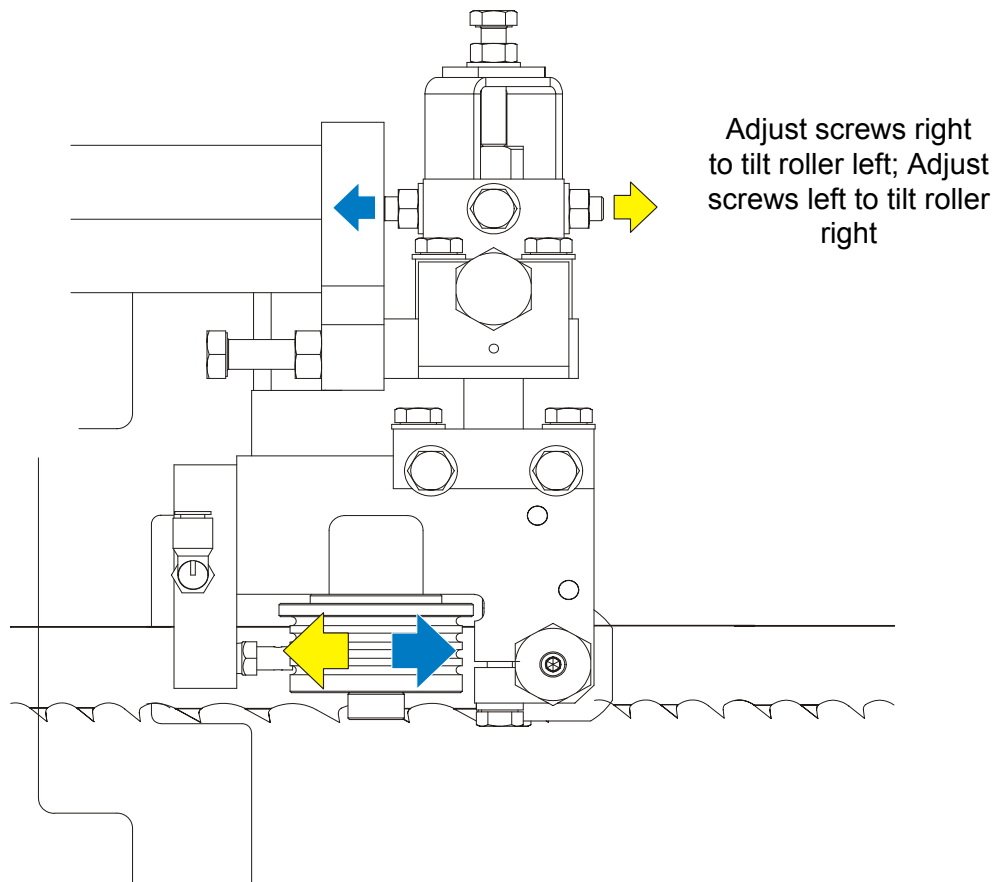

FIG. 7-11

5. Repeat the above steps for the inner blade guide roller assembly.

NOTE: Once the blade guides have been adjusted, any cutting variances are most likely caused by the blade. [See Blade Handbook, Form #600.](#)

Blade Guide Flange Spacing

Each blade guide must be adjusted so the roller flange is the correct distance from the back edge of the blade. If the flange is too close to or too far from the blade, the sawmill will not cut accurately.

HINT: When adjusting blade guide spacing, loosen the top set screw and one side set screw only. This will ensure horizontal and vertical tilt adjustments are maintained when the adjustment screws are retightened.

1. Measure the distance between the flange on the inner blade guide roller to the back edge of the blade. This distance should measure 3 mm. Adjust the roller back or forward if necessary.

See Figure 7-12. Loosen the top and one side screw shown and rear adjusting bolt if necessary. Tap the blade guide forward or backward until properly positioned. Retighten the screws and jam nuts.

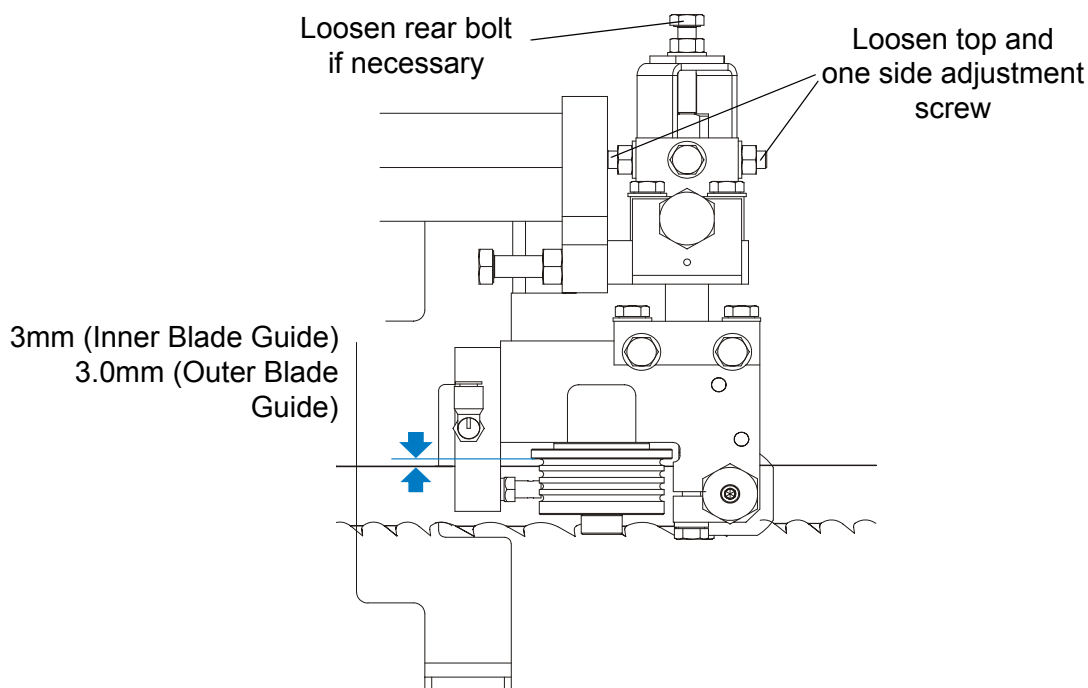

FIG. 7-12

2. Measure the distance between the flange on the outer blade guide roller to the back edge of the blade. This distance should measure 3.0 mm. Adjust the roller back or forward if necessary.

7.2 Horizontal Adjustment of Side Supports

Logs and boards are clamped against the side supports when sawing. The sides supports must be square to the bed to ensure square lumber.

1. Swing the side support down.
2. Measure between the face of the support and the main bed tube. Make measurements at both ends of the side support to make sure that it is parallel to the rail.

See Figure 7-13.

3. Use the two lower bolts to adjust the side support so $B=A$.
4. Repeat for remaining side supports.

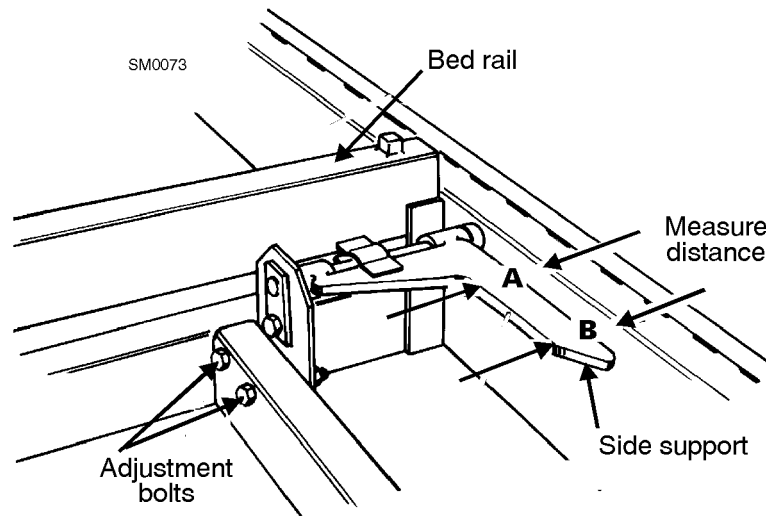

FIG. 7-13

7.3 Vertical Adjustment of Side Supports

1. Place a flat board across the bed rails.
2. Swing a side support up so that it is vertical.
3. Pull back at the top of the support to eliminate slack as if a log were being clamped against it.

See Figure 7-14.

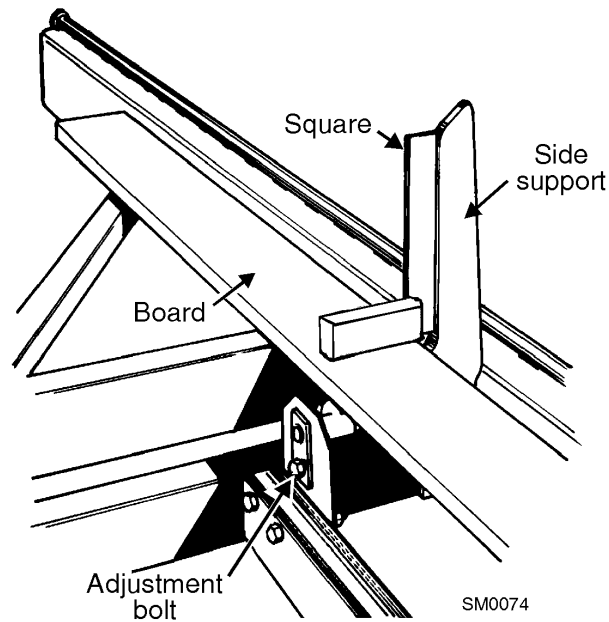

FIG. 7-14

4. Check the angle of each support with a square on the board.
5. The side support should be 90° to the bed rails. Loosen the top adjustment bolt, adjust the side support, and retighten the bolt.
6. Repeat for the remaining side supports.

Blade Height Scale Adjustment

After the entire sawmill has been aligned and all adjustments made, check that the blade height scale indicates the true distance from the blade to the bed rails.

1. Move the saw head so the blade is positioned directly above one of the bed rails. Measure from the bottom edge on a down-set tooth of the blade to the top of the bed rail, near the inner blade guide assembly.
2. View the blade height scale with eyes level with the indicator. The scale should indicate the actual distance from the blade to the bed rail. Adjust the indicator if necessary.

See Figure 7-15. Loosen the indicator bracket mounting bolts and adjust the bracket until the indicator is aligned with the correct mark on the scale. Retighten the bracket mounting nuts.

For example, if the measurement from the down-set tooth of the blade to the bed rail was 14 3/4" (375 mm), make sure the indicator reads 14 3/4" (375 mm) on the scale.

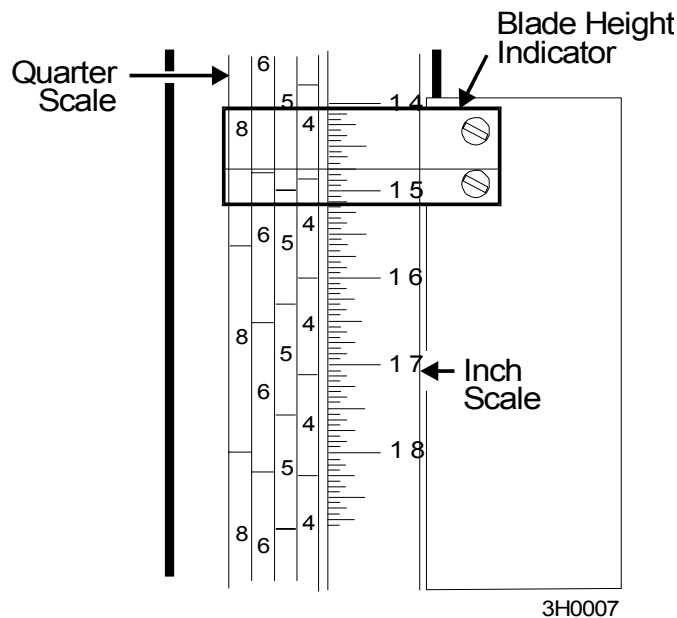

FIG. 7-15

7.4 Complete Alignment Procedure

Frame Setup

Before performing the following alignment procedures, setup the mill on firm, level ground.

If your sawmill is stationary, with no trailer axle, lower the feet so the weight of the sawmill is evenly supported.

If your sawmill has a trailer axle and adjustable outriggers, adjust the outriggers as follows:

LT70S: Adjust the two end outriggers on the main frame tube down just enough to lift weight from the trailer tire.

LT70M: Adjust the front and third outriggers on the main frame tube down just enough to lift weight from the trailer tire.

LT70L. Adjust front outriggers on the main frame tube down just enough to lift weight from the trailer tires.

All Portable Sawmills: Adjust the outer outriggers down just so they touch the ground but do not bear weight.

[See SECTION 3](#) for additional setup information.

Blade Installation

1. Remove the blade and replace the blade wheel belts. New blade wheel belts are required to perform the complete alignment procedure.
2. Blow sawdust off of the blade guide assemblies. Remove sawdust from the blade housings. Scrape any sawdust buildup from the blade wheel rims.
3. Remove the blade guide assemblies and the blade.

NOTE: To remove the blade guide assemblies and maintain the tilt adjustments, only loosen one side screw and the top screw. Leaving the other side screw and bottom screw in position will insure you will return the rollers to their original tilt adjustment.

4. Adjust the outer blade guide arm in or out until the outer blade guide is approximately 24” from the inner blade guide.
5. Install a new blade and apply the appropriate tension ([See Section 3.6](#)).
6. Close the blade housing covers and make sure all persons are clear of the saw head.
7. Turn the key switch to #3 position.
8. Engage the blade switch.



9. Manually spin one of the blade wheels until the blade positions itself on the blade wheels.

Blade Wheel Alignment

The blade wheels should be adjusted so they are level in the vertical and horizontal planes. If the blade wheels are tilted up or down, the blade will want to travel in the tilted direction. If the blade wheels are tilted horizontally, the blade will not track properly on the wheels.

1. Use the blade guide alignment tool to check the vertical alignment of each blade wheel. Attach the tool to the blade near the inner blade guide mount. Be sure the tool does not rest on a tooth or burr, and is lying flat against the bottom of the blade.

See Figure 7-16.

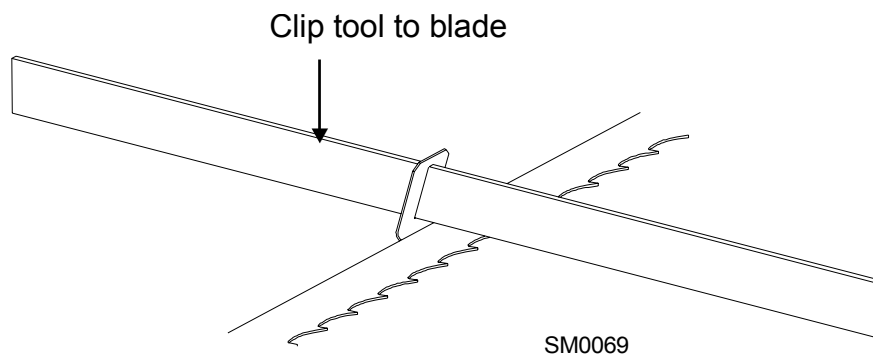

FIG. 7-16

2. Move the saw carriage so the front end of the tool is positioned over the first bed rail. Measure from the bottom of the tool to the top surface of the bed rail.
3. Move the saw carriage so the rear of the tool is positioned over the bed rail. Again, measure from the bottom of the tool to the bed rail.
4. If the two measurements differ by more than 1/16" (1.5 mm), adjust the vertical tilt of the drive-side blade wheel.

See Figure 7-17. Use the vertical adjustment screws to adjust the drive-side blade wheel. To tilt the wheel down, loosen the top adjustment screw one quarter turn. Loosen the jam nut on the bottom adjustment screw and tighten the screw. Tighten the top and bottom jam nuts.

To tilt the wheel up, loosen the bottom adjustment screw one quarter turn. Loosen the jam nut on the top adjustment screw and tighten the screw. Tighten the top and bottom jam nuts.

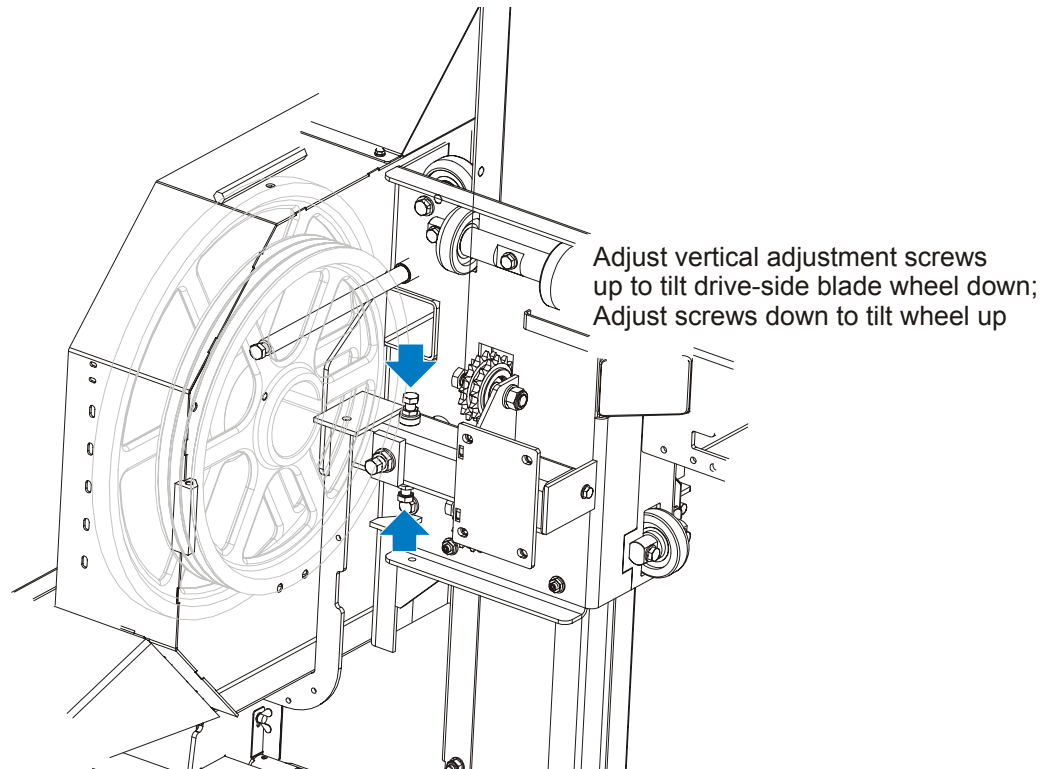

FIG. 7-17

5. Recheck the vertical tilt of the drive-side blade wheel with the blade guide alignment tool. Readjust the blade wheel as necessary until the front and rear of the tool are the same distance from the bed rail (within 1/16" [1.5 mm]).
6. Remove the tool from the blade and reattach it near the outer blade guide assembly.
7. Measure from the tool to the bed rail at both ends of the tool. If the measurements at the front and rear ends of the tool differ by more than 1/16" (1.5 mm), adjust the vertical tilt of the idle-side blade wheel.

See Figure 7-18. Use the vertical adjustment screws to adjust the idle-side blade wheel. To tilt the wheel up, loosen the bottom adjustment screw one quarter turn. Loosen the jam nut on the top adjustment screw and tighten the screw. Tighten the top and bottom jam nuts.

To tilt the wheel down, loosen the top adjustment screw one quarter turn. Loosen the jam nut on the bottom adjustment screw and tighten the screw. Tighten the top and bottom jam nuts.

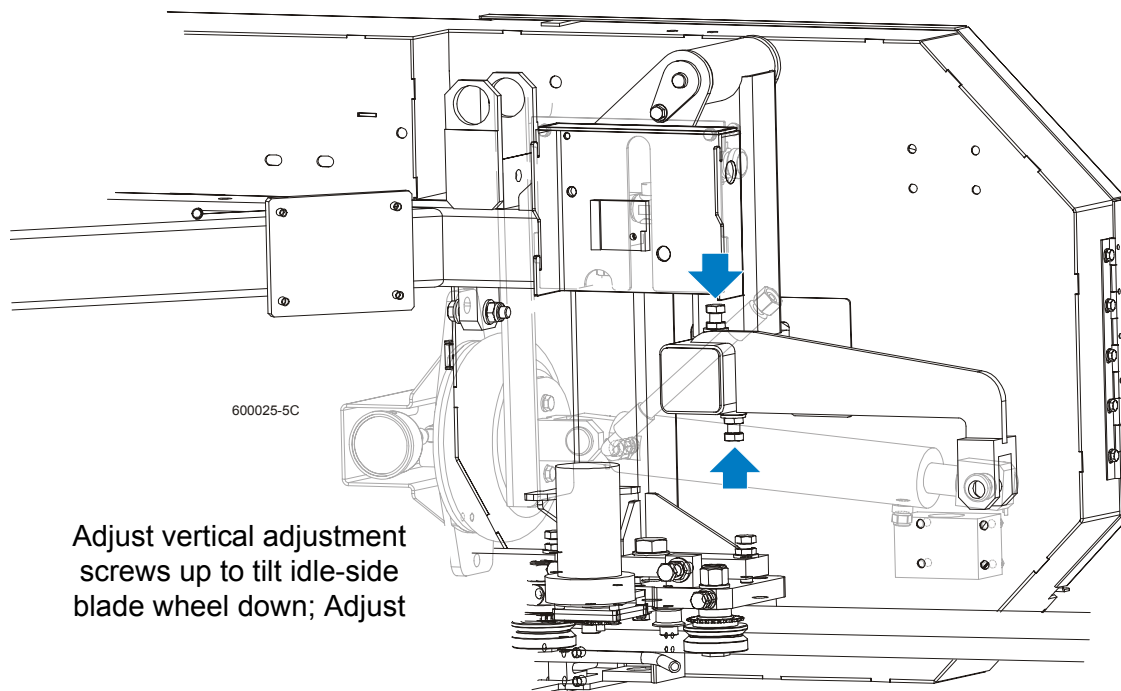

FIG. 7-18

8. Recheck the vertical tilt of the idle-side blade wheel with the blade guide alignment tool. Readjust the blade wheel as necessary until the front and rear of the tool are the same distance from the bed rail (within 1/16" [1.5 mm]).

9. Check the position of the blade on the idle-side blade wheel.

See Figure 7-19. The horizontal tilt of the blade wheel should be adjusted so that the gullet of a 1-1/4" blade is 1/8" (3 mm) out from the front edge of the wheel ($\pm 1/26$ [1mm]). The gullet of a 1-1/2" blade should be 3/16" (4.5 mm) out from the front edge of the wheel ($\pm 1/26$ [1 mm]). Do not let the teeth ride on the wheels.

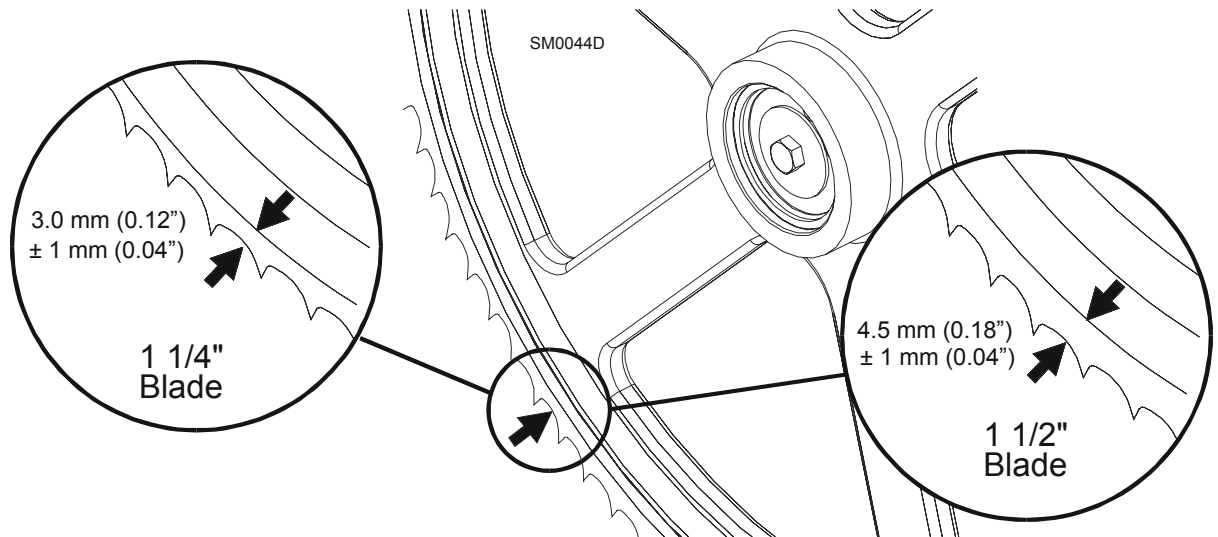

FIG. 7-19

See Figure 7-20. Use the cant control adjustment to adjust the idle-side blade wheel. If the blade is too far forward on the wheel, turn the cant control counterclockwise. If it is too far back on the wheel, turn the cant control clockwise.

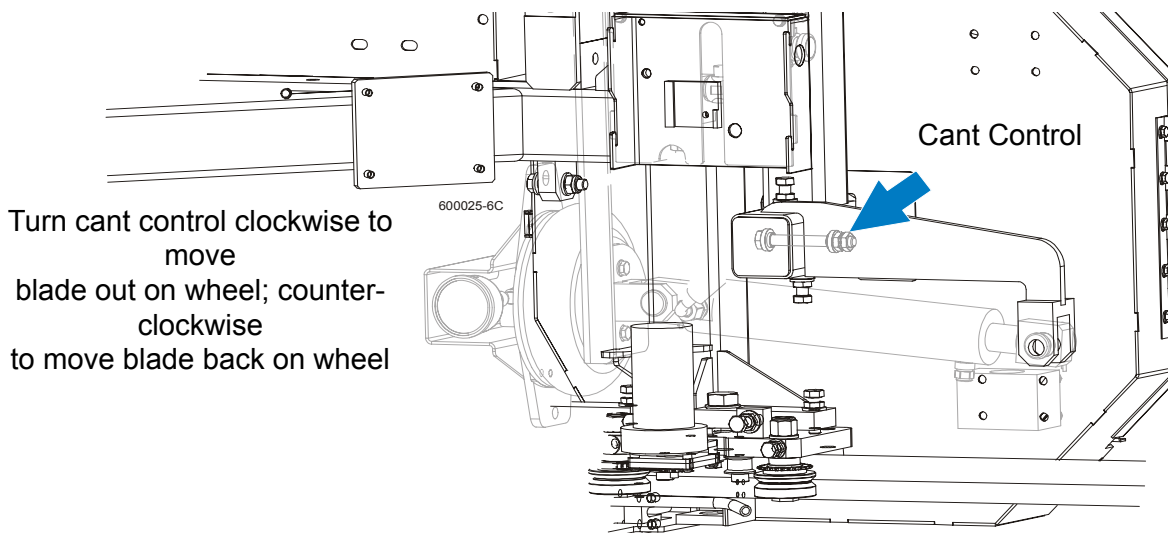

FIG. 7-20

10. Check the position of the blade on the drive-side blade wheel. The blade should be positioned on the wheel as described for the idle-side blade wheel. Adjust the drive-side blade wheel if necessary.

See Figure 7-21. Use the horizontal adjustment screw to adjust the drive-side blade wheel. To move the blade back on the wheel, loosen the jam nut on the adjustment screw and tighten the screw.

7 Sawmill Alignment

Complete Alignment Procedure

Tighten the jam nut.

To move the blade out on the wheel, loosen the jam nut on the adjustment screw and loosen the screw. Tighten the jam nut.

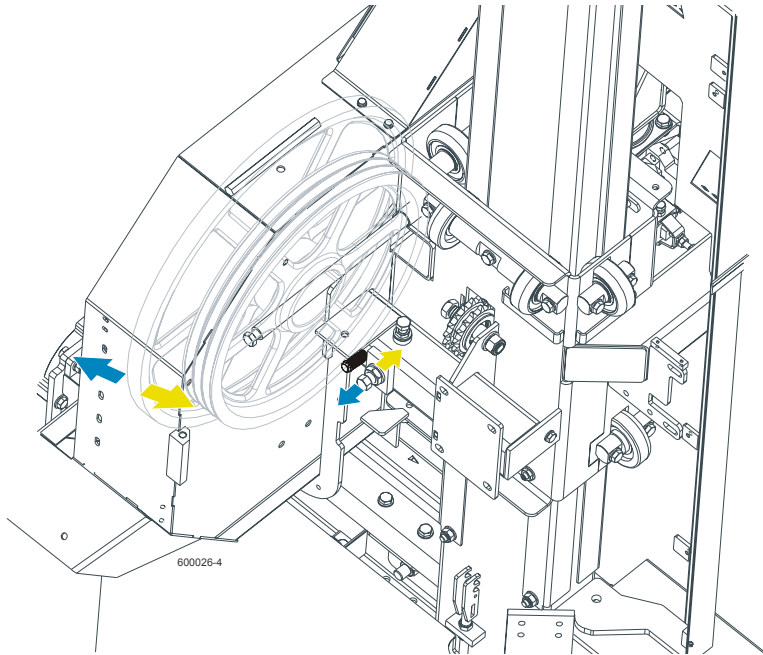

Loosen adjustment bolt to move blade out on wheel; Tighten adjustment bolt to move blade in on wheel

FIG. 7-21

Bed Rail Adjustment

1. Open the adjustable blade guide arm to within 1/2" (15 mm) of full open.
2. Move the carriage back to the front pivot bed rail. Raise the cutting head until the bottom of the blade is 17" (400 mm) above the outside of the pivot bed rail support by actual measurement with a tape or ruler.

See Figure 7-22.

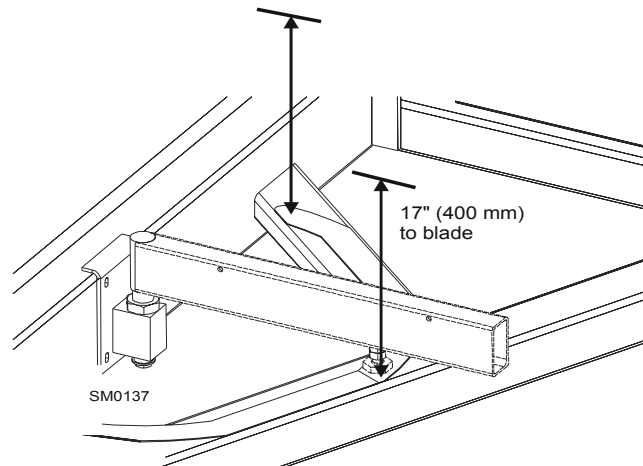

FIG. 7-22

3. Move the carriage forward to check the distance to the blade at the inside of the pivot bed rail support. All measurements should be equal.

See Figure 7-23. To adjust the saw head tilt, use the bolts located at the bottom of the saw head mast. Loosen the three sets of four retaining plate bolts. To raise the outside of the saw head, back the stop bolts out, then tighten the adjustment bolts. To lower the outside of the saw head, loosen the adjustment bolts and tighten the stop bolts. Recheck the saw head tilt and readjust the bolts as necessary. Retighten the retaining plate bolts.

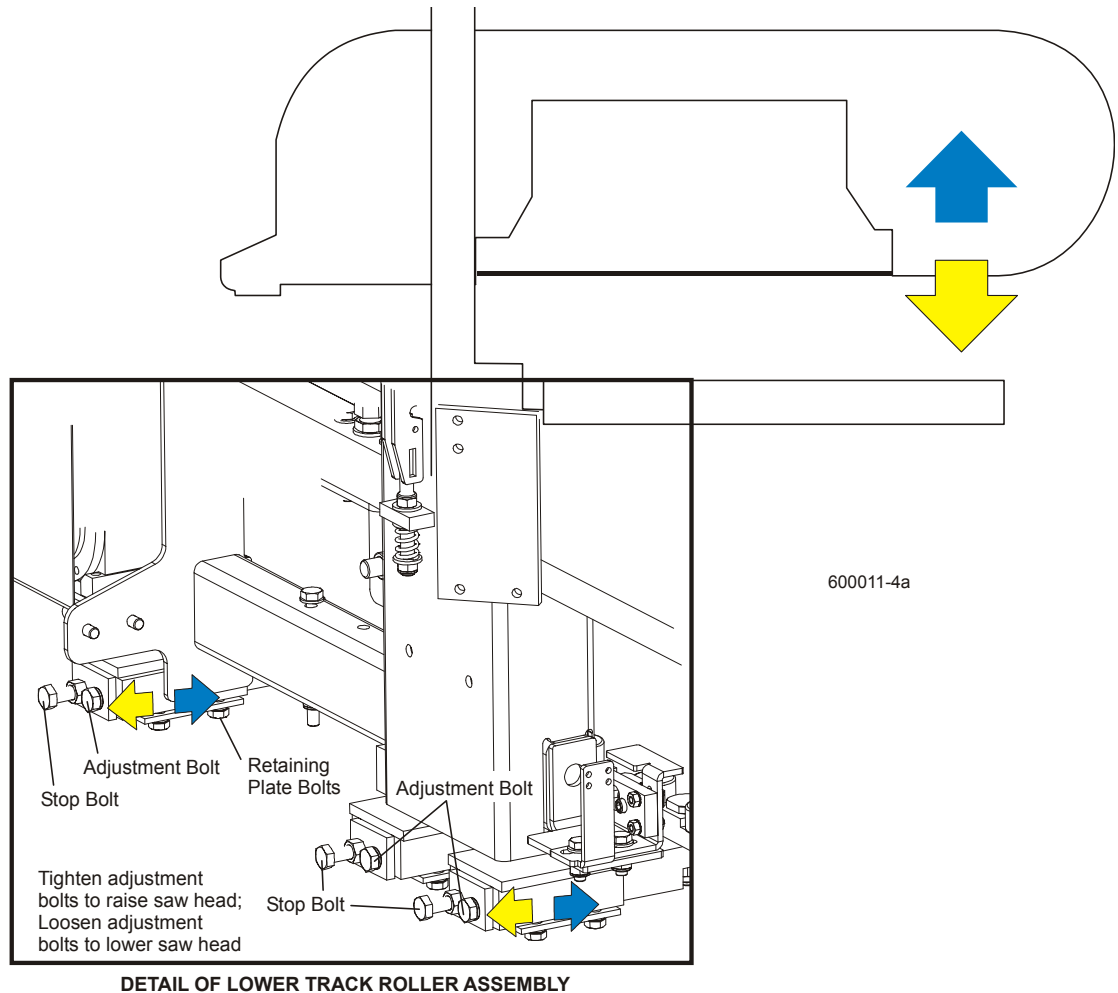

FIG. 7-23

4. Move the clamp so it is 10" from the clamp stop. Adjust the clamp down to its lowest position. Move the saw head forward until it is positioned over the clamp. Raise the saw head until the blade measures 15 5/16" (385 mm) from the clamp at its lowest position.
5. Adjust the front pivot rail 90° to the main bed tube.
6. Move the saw head to center the blade over the front pivot bed rail.

7. Measure the distance from the top of the pivot rail to the bottom of the blade. Make this measurement at each end of the pivot rail.
8. The two measurements should be 15" (375 mm).

See Figure 7-24. Loosen the locking set screws and turn the inner height adjustment nut to adjust the height of the inner end of the pivot rail. Loosen the jam nut and turn the outer adjustment bolt to adjust the height of the outer end of the pivot rail.

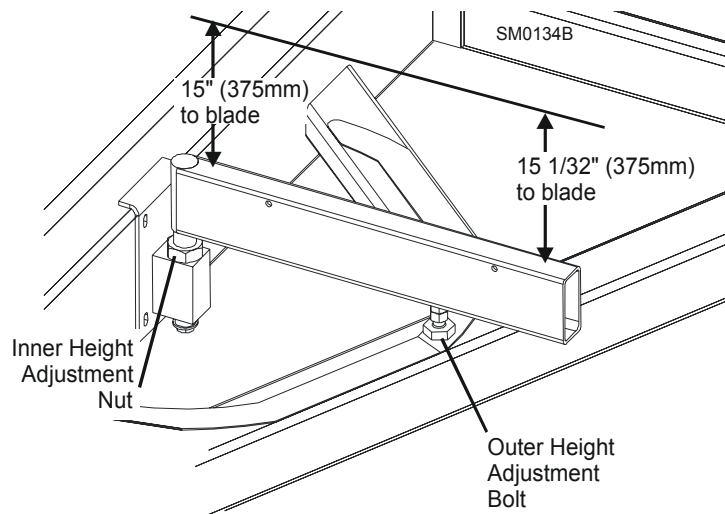

FIG. 7-24

9. Move the saw head so the blade is positioned over the center of the front main bed rail.
10. Measure the distance between the bottom of the blade and the bed rail at each end of the bed rail. The bed rail should measure 15" (375 mm) from the blade to the bed rail (+1mm at the outer side).

See **Figure 7-25**. Loosen the bed rail clamping bolts and turn the adjustment bolts to move the bed rails to the blade if necessary. Retighten the clamping bolts and adjustment bolt jam nuts.

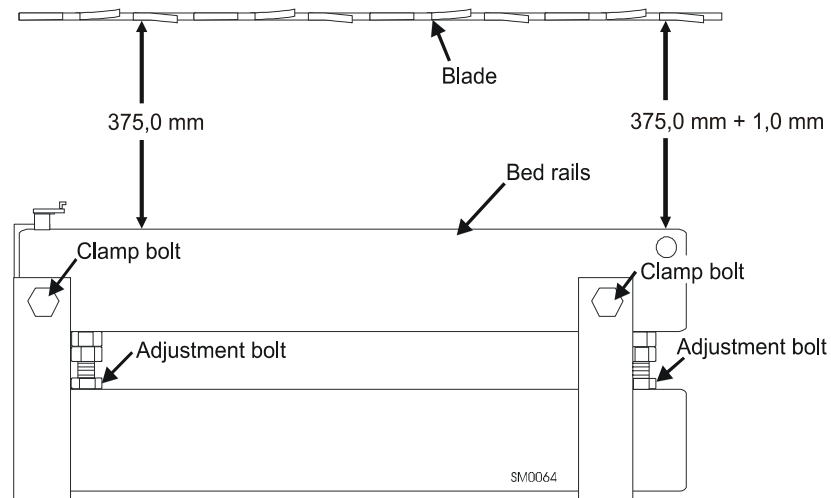

FIG. 7-25

11. Without adjusting the saw head height, check the three remaining main bed rails and the rear pivot rail. Adjust them so that all measure the same distance from the blade at both ends of the bed rail.

Blade Guide Installation

Each Wood-Mizer sawmill has two blade guide assemblies that help the blade maintain a straight cut. The two blade guide assemblies are positioned on the saw head to guide the blade on each side of the material being cut.

One blade guide assembly is mounted in a stationary position on the drive side of the saw head. This assembly is referred to as the "inner" blade guide assembly.

The other blade guide assembly is mounted on the idle side of the saw head. It is referred to as the "outer" assembly and is adjustable for various widths of materials to be processed.

NOTE: Before installing the blade guide assemblies, remove the blade guide adjusting screws and apply a lubricating oil such as 10W30 or Dexron III to each screw. This will prevent the screws and threaded holes from corroding and make screw adjustments easier.

1. Inspect the guide disks and repair or replace as necessary. Remove the blade from the sawmill.

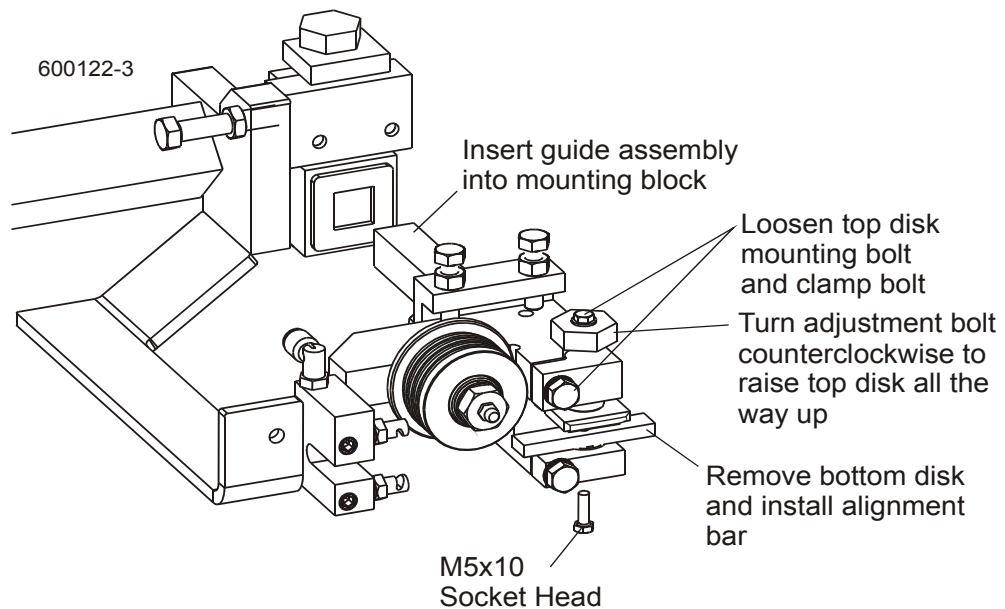

FIG. 7-25

2. Loosen the top disk clamp bolt and mounting bolt. Turn the adjustment bolt counterclockwise to raise the top disk all the way up. Remove the bottom guide disk from each blade guide assembly and install the provided alignment bar.
3. Install each blade guide assembly to the mounting blocks and push all the way back. Install, tension and track a new blade. Adjust the outer blade guide assembly so the roller flange is 3mm from the back of the blade. Adjust the inner blade guide assembly so the roller flange is 3mm from the blade.

See Figure 7-26.

7 Sawmill Alignment

Complete Alignment Procedure

Tighten the two previously-loosened tilt adjustment screws to secure the blade guide assembly. Turn the top adjustment bolt clockwise to raise the blade guide assembly so it does not touch the blade.

NOTE: Before adjusting the top bolt, unload pressure on the bolt by turning 1/2 turn in the opposite direction it was last adjusted.

With the roller flange positioned properly from the back of the blade, adjust the rear bolt so it touches the end of the blade guide mounting shaft.

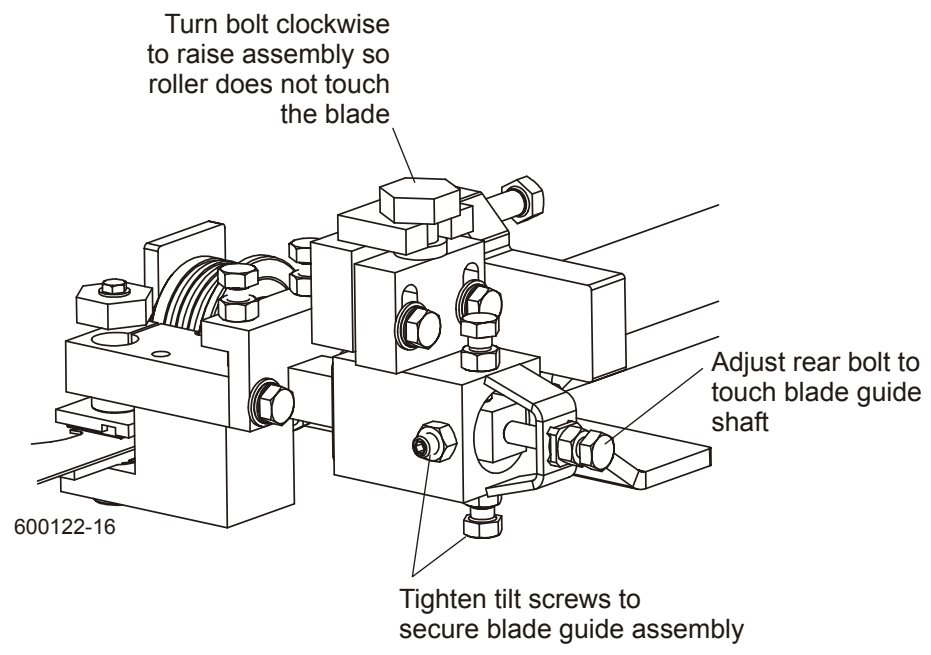

FIG. 7-26

Blade Guide Arm Alignment

The blade guide arm moves the outer blade guide in and out. If the arm becomes loose, the blade guide will not deflect the blade properly, causing inaccurate cuts. A loose blade guide arm can also cause blade vibration.

1. Adjust the blade guide arm in to 1/2" (15 mm) from fully closed.
2. Manually try to move the arm up and down. If you can move the arm by hand, you will need to tighten the arm rollers.

See Figure 7-27. Loosen the jam nuts and turn the adjustment bolts in to tighten the blade guide arm rollers. Retighten the jam nuts.

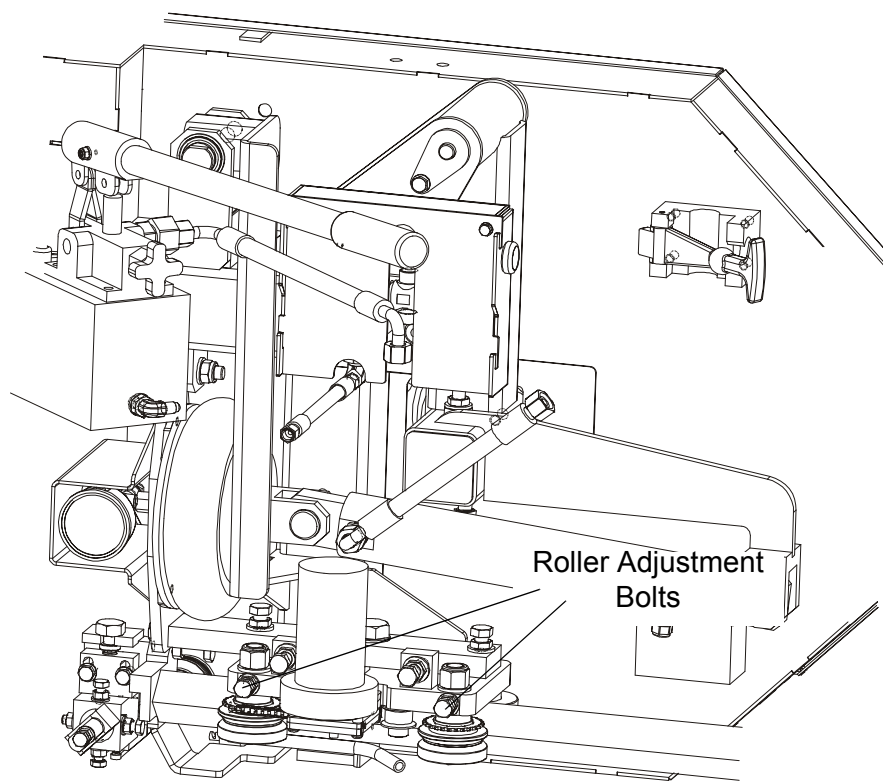

FIG. 7-27

After tightening the blade guide arm rollers, check that the arm is aligned properly.

3. With the arm adjusted 1/2" (15 mm) from fully closed, measure the distance between the rear blade guide roller and the back of the blade.

See Figure 7-28.

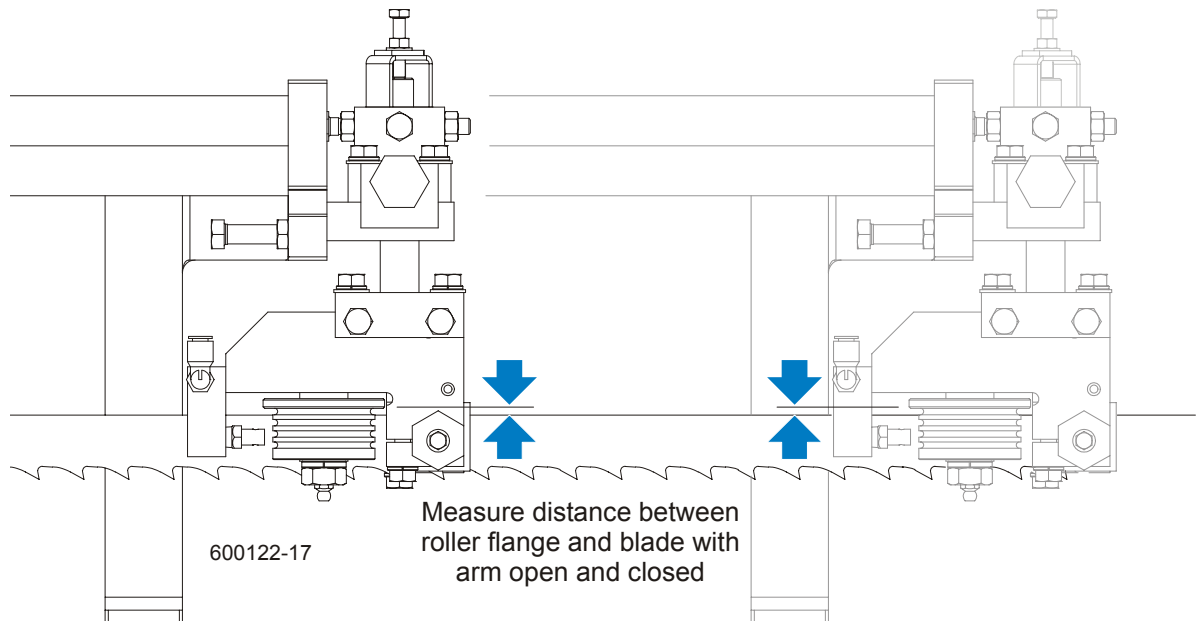

FIG. 7-28

4. Adjust the blade guide arm to 1/2" (15 mm) from fully open and remeasure the distance from the roller flange to the back of the blade. The two measurements should be the same. If not, adjust the outer rollers in or out to tilt the arm horizontally.

See Figure 7-29. Loosen the horizontal adjustment bolt jam nuts. To tilt the arm in toward the blade, loosen the rear bolt and tighten the front bolt. To tilt the arm out away from the blade, loosen the front bolt and tighten the rear bolt. Retighten the jam nuts and recheck the blade guide arm horizontal tilt.

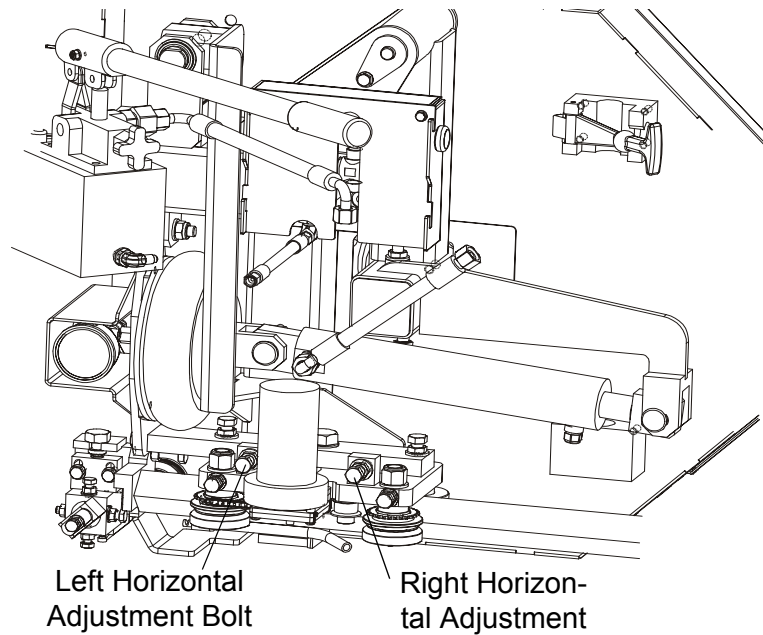

FIG. 7-29

5. Now check the vertical tilt of the blade guide arm. Move the saw carriage so the blade guide arm is positioned over a bed rail.
6. With the arm 1/2" (15 mm) from fully closed, raise or lower the saw head until the bottom of the blade guide block is 15" (375 mm) from the top of the bed rail.

See Figure 7-30. Adjust the blade guide arm to 1/2" (15 mm) from fully open. Measure the distance from the bottom of the blade guide mounting block to the bed rail. This measurement should be 15" (376 mm). If the measurements are not the same, adjust the blade guide arm vertically.

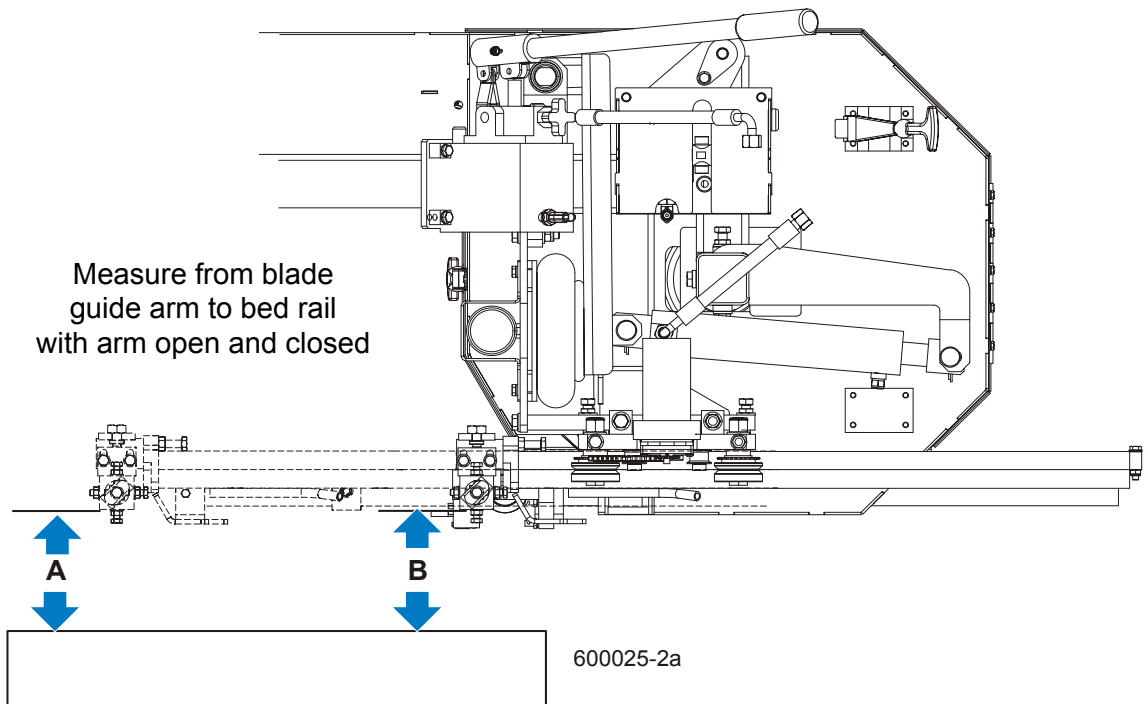

FIG. 7-30

See Figure 7-31. Loosen the vertical adjustment bolt jam nuts. To tilt the blade guide arm down, loosen the rear bolt and tighten the front bolt. To tilt the blade guide arm up, loosen the front bolt and tighten the rear bolt. Retighten the jam nuts and recheck the blade guide arm vertical tilt.

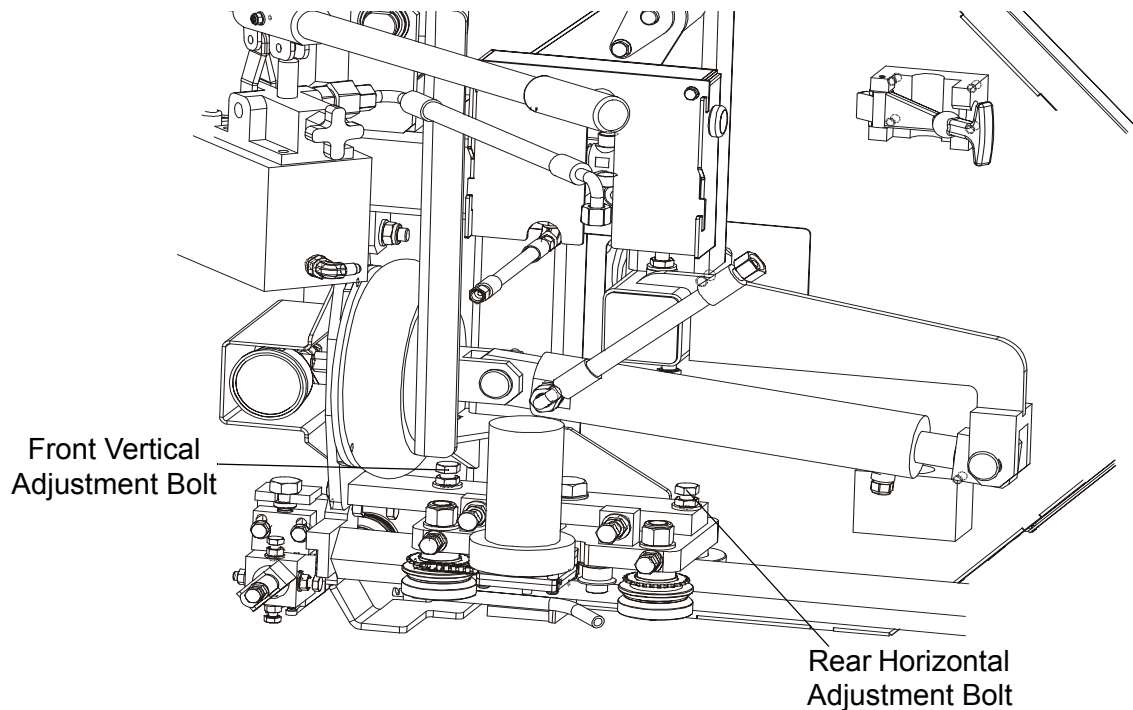

FIG. 7-31

Blade Guide Deflection

Perform the following steps to achieve proper blade deflection with the blade guides.

1. Raise the carriage until the blade is 375 mm above a bed rail. Measure the actual distance with a tape from the top of the rail to the bottom of the blade.

See Figure 7-32.

Loosen the clamp bolts. Turn the top adjustment bolt counterclockwise to lower the assembly until the blade guide roller deflects the blade down until the bottom of the blade measures 369 mm from

the bed rail. Tighten the clamp bolts.

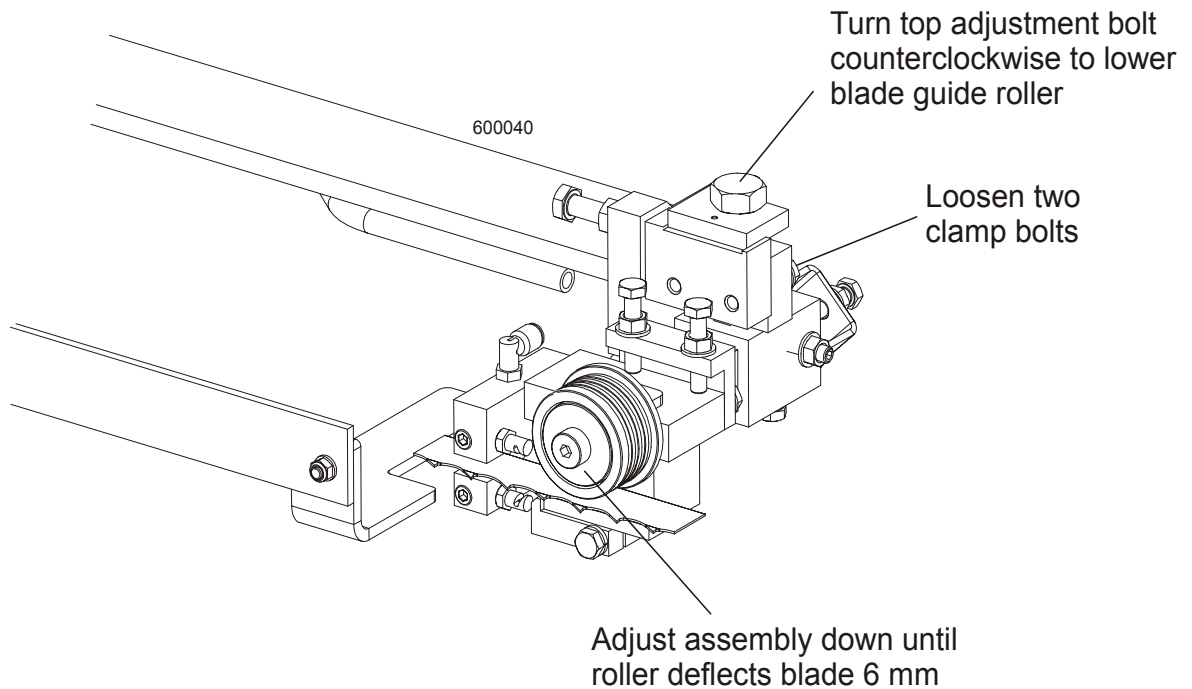

FIG. 7-32

2. Repeat for the other blade guide.

Blade Guide Vertical Tilt Alignment

The blade guides should be adjusted properly in the vertical plane. If the blade guides are tilted vertically, the blade will try to travel in the tilted direction.

A Blade Guide Alignment Tool (BGAT) is provided to help you measure the vertical tilt of the blade.

1. Open the adjustable blade guide arm 1/2" (15 mm) from full open.
2. Clip the alignment tool on the blade. Position the tool close to the outer blade guide roller. Be sure the tool does not rest on a tooth or burr, and is lying flat on the blade.

See Figure 7-33.

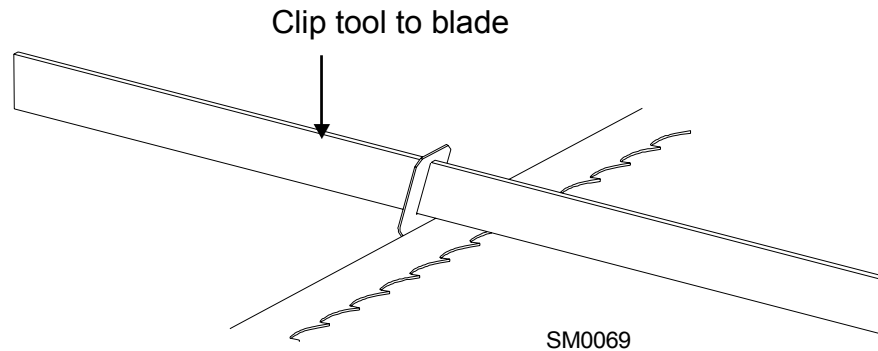

FIG. 7-33

3. Move the carriage so that the front end of the tool is positioned above the bed rail. Measure the distance from the bed rail to the bottom edge of the tool.
4. Move the carriage so that the back end of the tool is positioned above the bed rail. Measure the distance from the bed rail to the bottom edge of the tool.
5. If the measurement from the tool to the bed rail is not equal, adjust the vertical tilt of the outer blade guide roller.

See Figure 7-34. Loosen the jam nuts on the top and bottom vertical tilt adjustment screws. To tilt

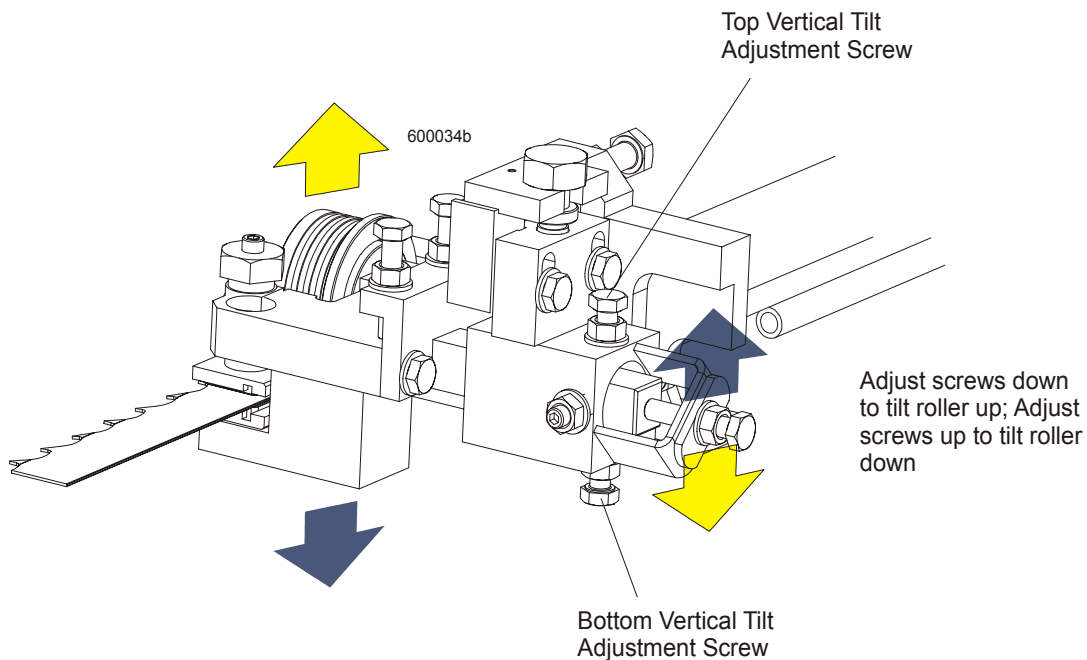

FIG. 7-34

the roller up, loosen the bottom screw and tighten top screw. To tilt the roller down, loosen the top

screw and tighten the bottom screw. Tighten the jam nuts and recheck the tilt of the blade.

6. Move the blade guide alignment tool close to the inner blade guide roller assembly and repeat the above steps. Adjust the vertical tilt of the inner blade guide if necessary.

Blade Guide Horizontal Tilt Adjustment

If the blade guides are tilted in the wrong direction horizontally, the back of the blade may contact the flange as the roller is spinning down, causing it to push the blade away from the guide roller.

1. Remove the blade guide alignment tool from the blade and adjust the blade guide arm halfway in.
2. Remove the clip from the blade guide alignment tool. Place the tool against the face of the outer blade guide roller.

See Figure 7-35.

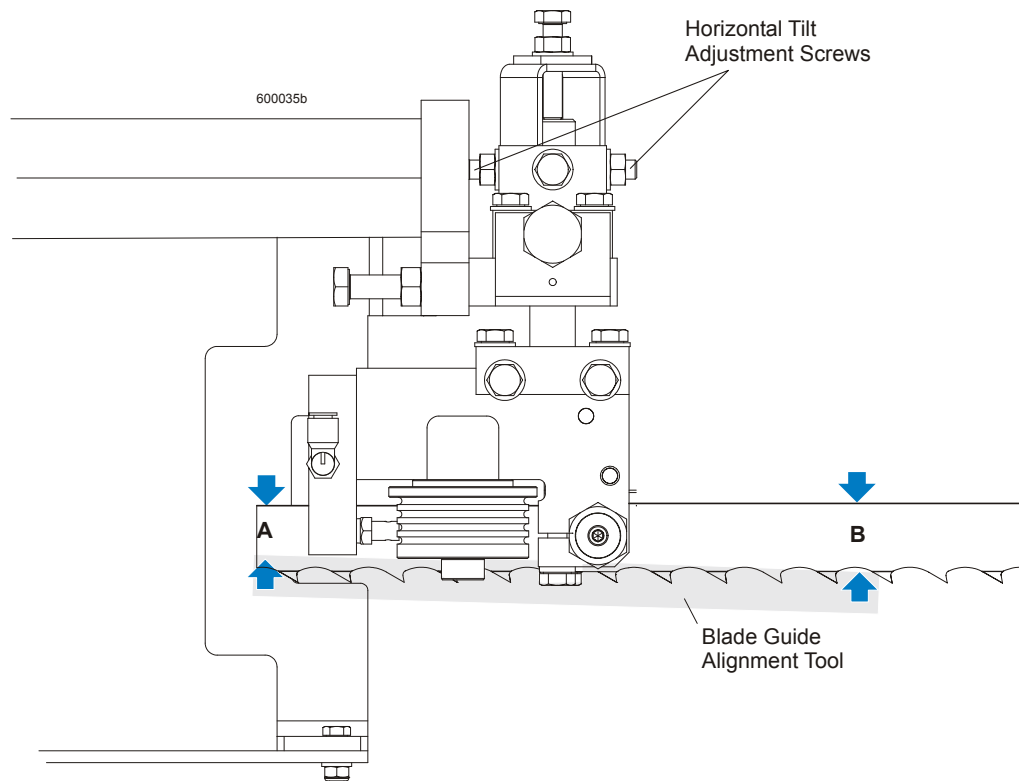

FIG. 7-35

3. Measure between the back edge of the blade and the tool at the end closest to the inner blade guide ("B").
4. Measure between the back edge of the blade and the other end of the tool ("A").

The roller should be tilted slightly to the left ('A' 1/8" [3 mm] less than 'B' ±1/8" [3 mm]).

See Figure 7-36. Loosen the jam nuts on the horizontal tilt adjustment screws. To tilt the roller left,

loosen the right screw and tighten left screw. To tilt the roller right, loosen the left screw and tighten the right screw. Tighten the jam nuts and recheck the tilt of the blade.

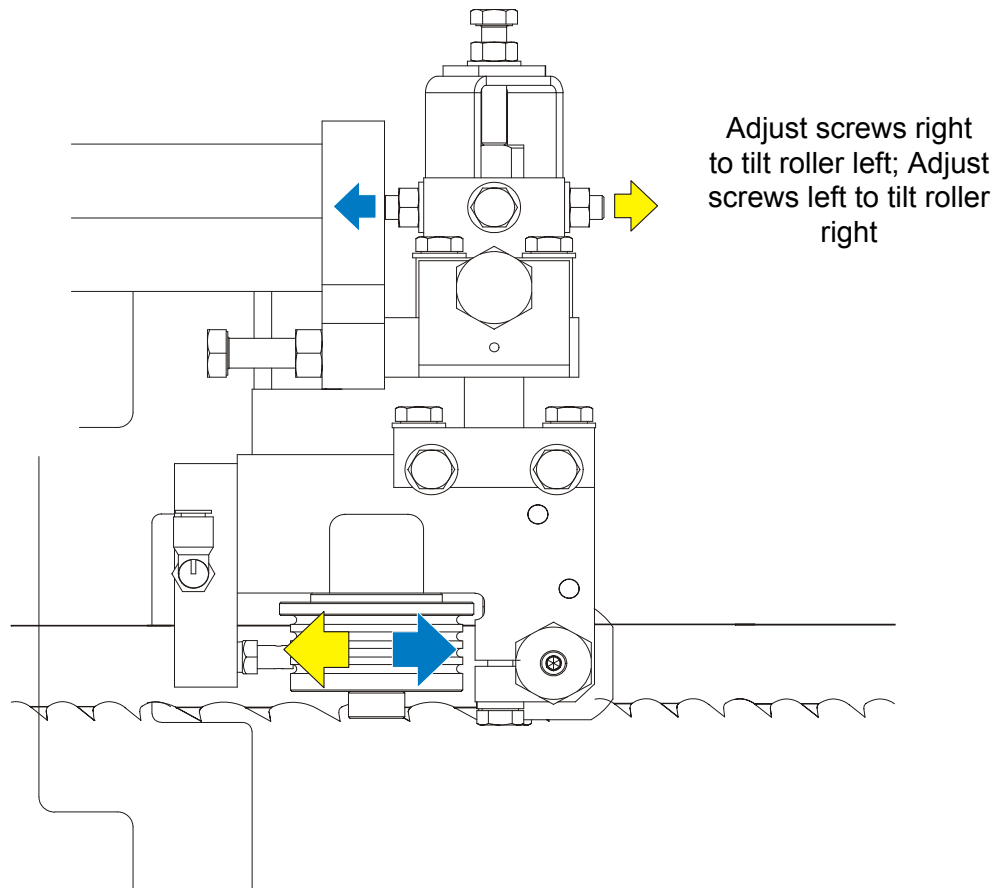

FIG. 7-36

5. Repeat the above steps for the inner blade guide roller assembly.

NOTE: Once the blade guides have been adjusted, any cutting variances are most likely caused by the blade. [See Blade Handbook Form #600.](#)

Blade Guide Flange Spacing

Each blade guide must be adjusted so the roller flange is the correct distance from the back edge of the blade. If the flange is too close to or too far from the blade, the sawmill will not cut accurately.

HINT: When adjusting blade guide spacing, loosen the top set screw and one side set screw only. This will ensure horizontal and vertical tilt adjustments are maintained when the adjustment screws are retightened.

1. Measure the distance between the flange on the inner blade guide roller to the back edge of the blade. This distance should measure 3 mm. Adjust the roller back or forward if necessary.

See Figure 7-37. Loosen the top and one side screw shown and rear adjusting bolt if necessary. Tap the blade guide forward or backward until properly positioned. Retighten the screws and jam nuts.

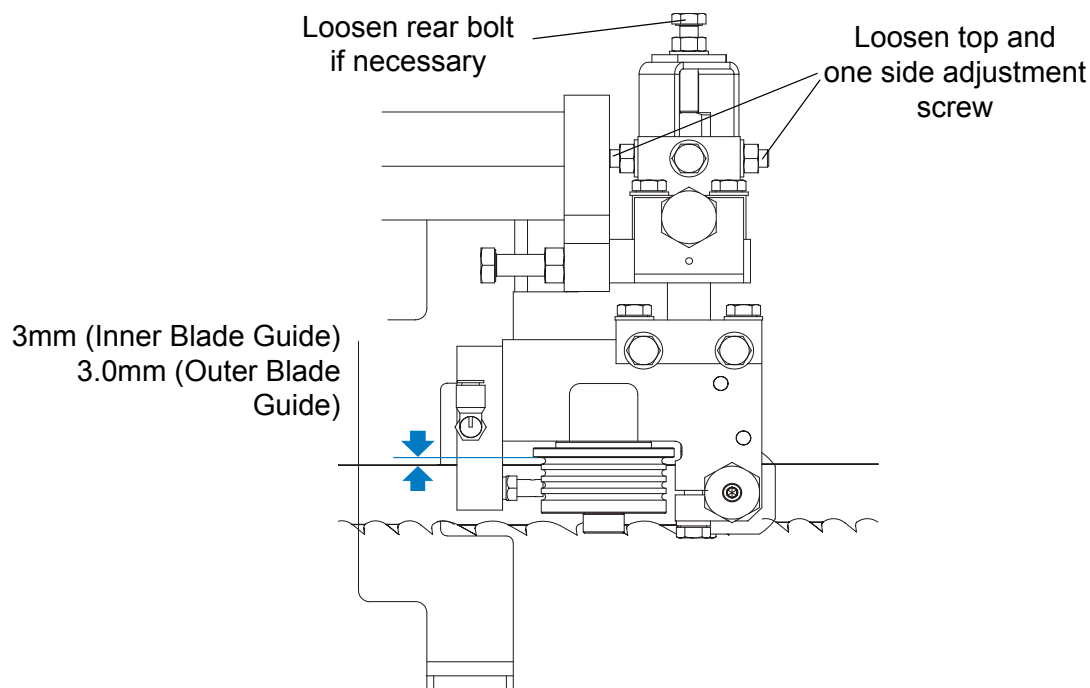

FIG. 7-37

2. Measure the distance between the flange on the outer blade guide roller to the back edge of the blade. This distance should measure 3.0 mm. Adjust the roller back or forward if necessary.

Blade Guide Level

Perform the following adjustments to make sure the blade guide assembly is parallel to the blade.

1. Loosen the alignment bar mounting bolt. Use the provided bottom disk adjustment tool to adjust the alignment bar up so the bar is close to, but not touching the bottom of the blade. Retighten the alignment bar mounting bolt
2. Check that the gap from the alignment bar to the blade is the same along entire length of the bar. Shine a flashlight behind the blade guide assembly to help you see the gap between the bar and the blade. To adjust, loosen the rear clamp bolts, but leave snug. Determine which outer bolt to use to tilt the blade guide assembly as desired. Loosen the jam nut and turn the bolt until the alignment bar is parallel to the blade. Retighten the jam nut and clamp bolts. Repeat for the second blade guide assembly.

See Figure 7-38.

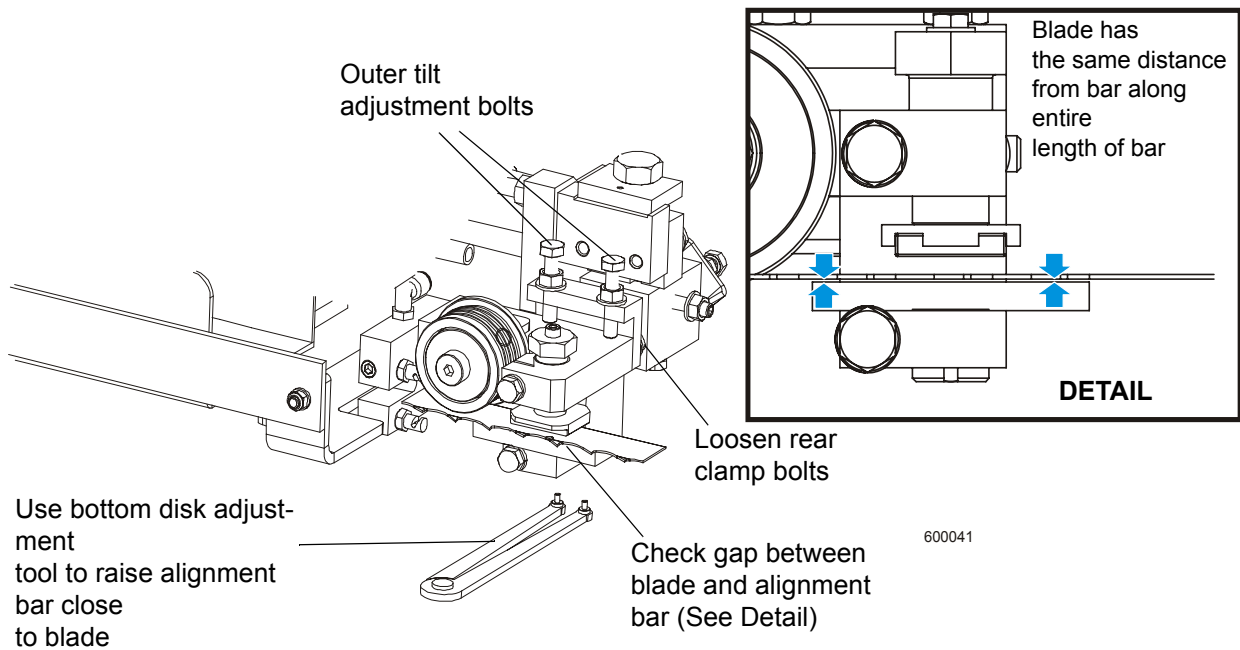

FIG. 7-38

Blade Disk Adjustment

1. Remove the blade and remove the alignment bars from the blade guide assemblies. Install new or reconditioned bottom guide disks to both blade guide assemblies (leave mounting bolts loose). Use the provided bottom disk adjustment tool to lower the bottom disk all the way down. Install, tension and track the blade.

See Figure 7-39.

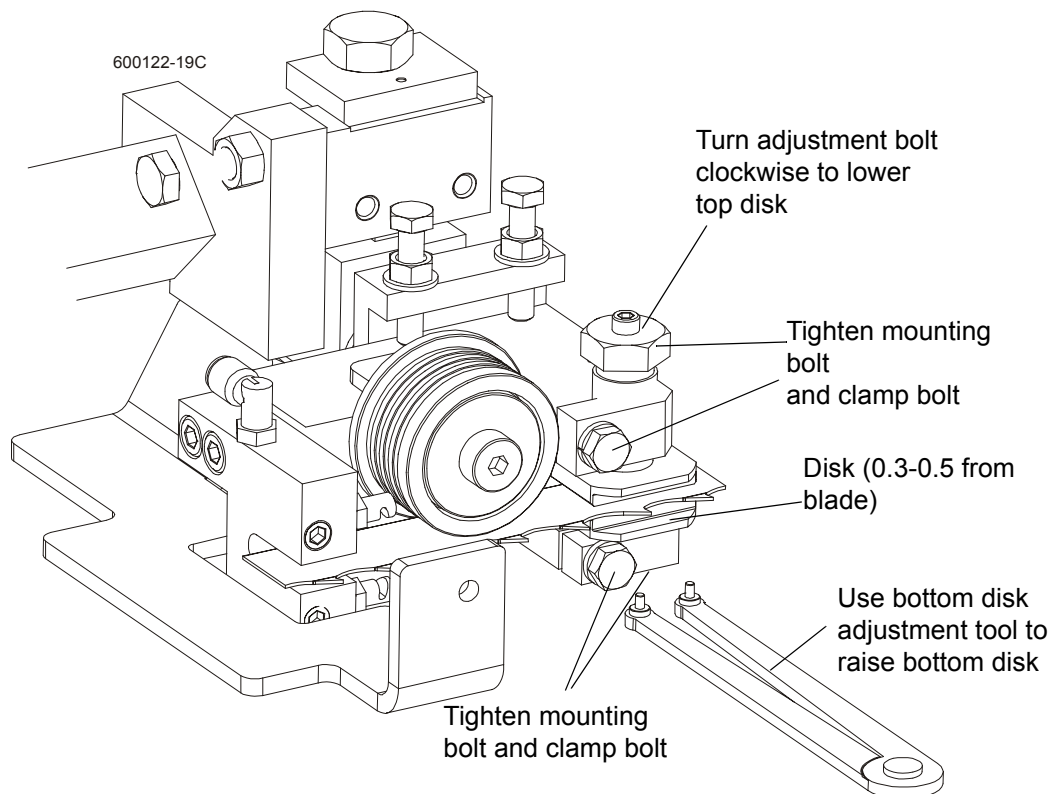

FIG. 7-39

2. Use the bottom disk adjustment tool to raise the bottom disk to 0.3- 0.5 mm from the blade. Use the provided shim to set the distance from the disk to the blade. Tighten the bottom disk mounting bolt and clamp bolt.
3. Turn the top disk adjustment bolt clockwise to lower the top disk to 0.3- 0.5mm from the blade (using the shim as a guide). Tighten the top disk mounting bolt and clamp bolt.
4. After tightening the clamp bolt, recheck the distance from the top disk to the blade and readjust if necessary.

Horizontal Alignment of Side Supports

Logs and boards are clamped against the side supports when sawing. The sides supports must be square to the bed to ensure square lumber.

1. Swing the side support down.
2. Measure between the face of the support and the main bed tube. Make measurements at both ends of the side support to make sure that it is parallel to the rail.

See Figure 7-40.

3. Use the two lower bolts to adjust the side support so $B=A$.
4. Repeat for remaining side supports.

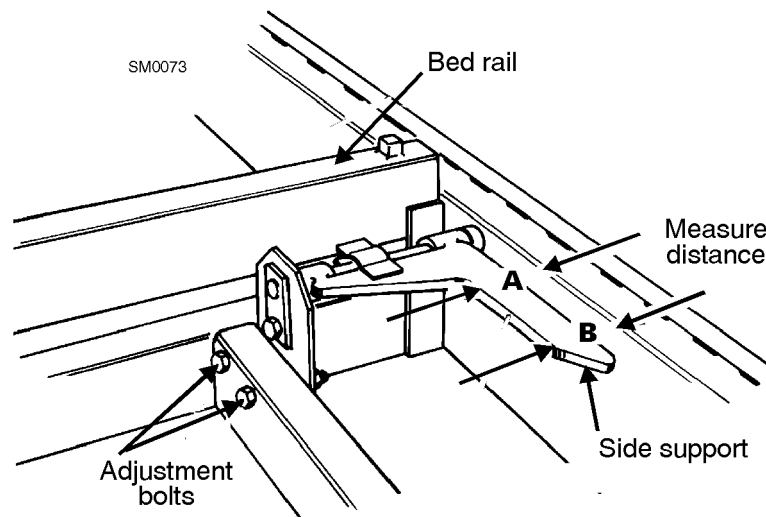

FIG. 7-40

Vertical Side Support Alignment

1. Place a flat board across the bed rails.
2. Swing a side support up so that it is vertical.
3. Pull back at the top of the support to eliminate slack as if a log were being clamped against it.

See Figure 7-41.

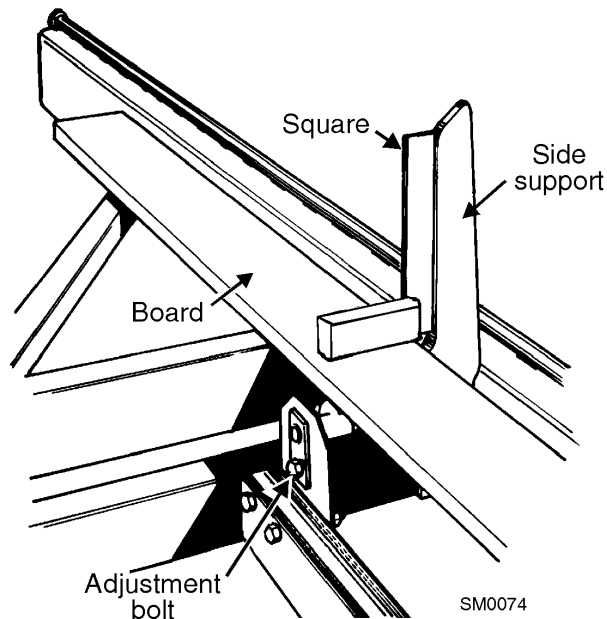

FIG. 7-41

4. Check the angle of each support with a square on the board.
5. The side support should be 90° to the bed rails. Loosen the top adjustment bolt, adjust the side support, and retighten the bolt.
6. Repeat for the remaining side supports.

Clamp Stop/Stop Bolt Adjustment

1. Once the side supports are aligned, pivot them down to their horizontal position.
2. Tie a string to the stop block at the first bed rail. Stretch the string toward the rear of the frame and tie to the stop block at the last bed rail.

See Figure 7-42. Loosen the clamp stop bolts and adjust the clamp stop until it touches the string.

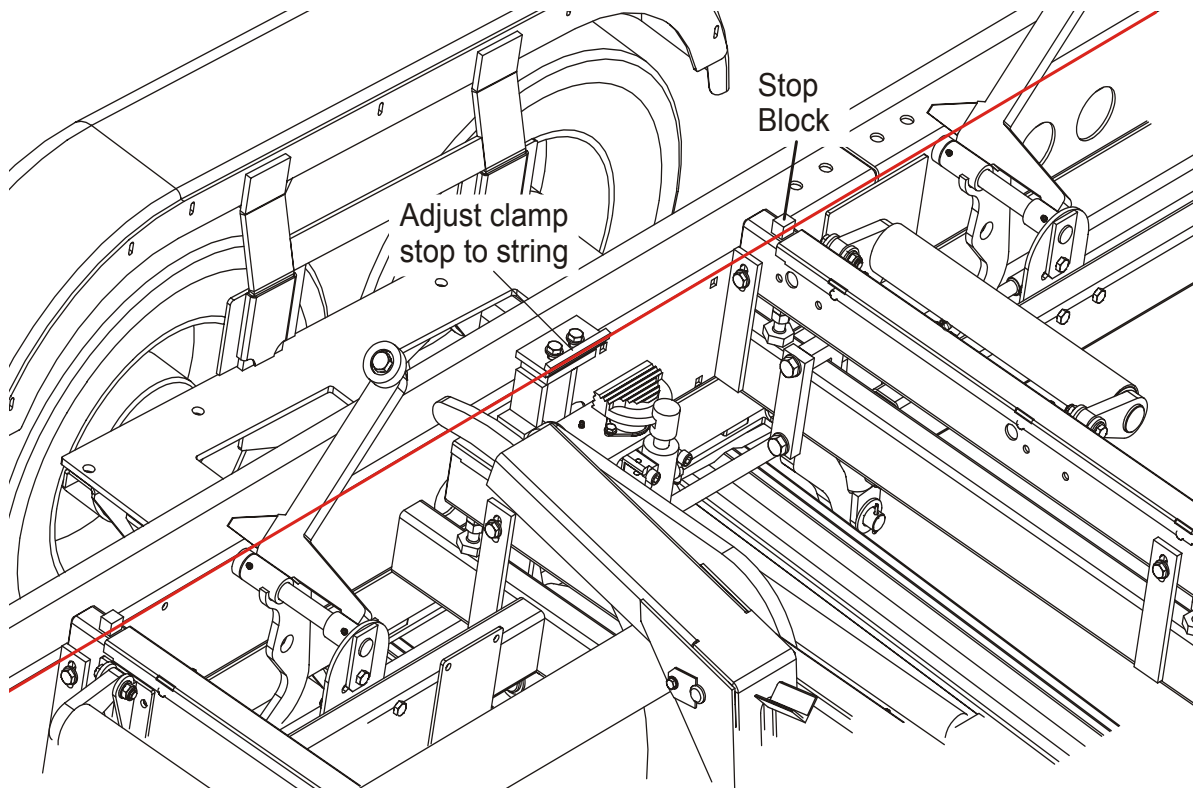

FIG. 7-42

Saw Head Tilt

As the blade enters a wide log or cant, the outside of the saw head will drop down slightly. To compensate for the drop, the saw head is adjusted 1/16" (1.5 mm) higher at the outside.

1. Move the saw carriage so the blade is positioned over a bed rail. Adjust the blade guide arm to 1/2" (15 mm) from full open. The saw head should still be adjusted so the blade is 14 3/4" (375 mm) above the bed rails.

See Figure 7-43.

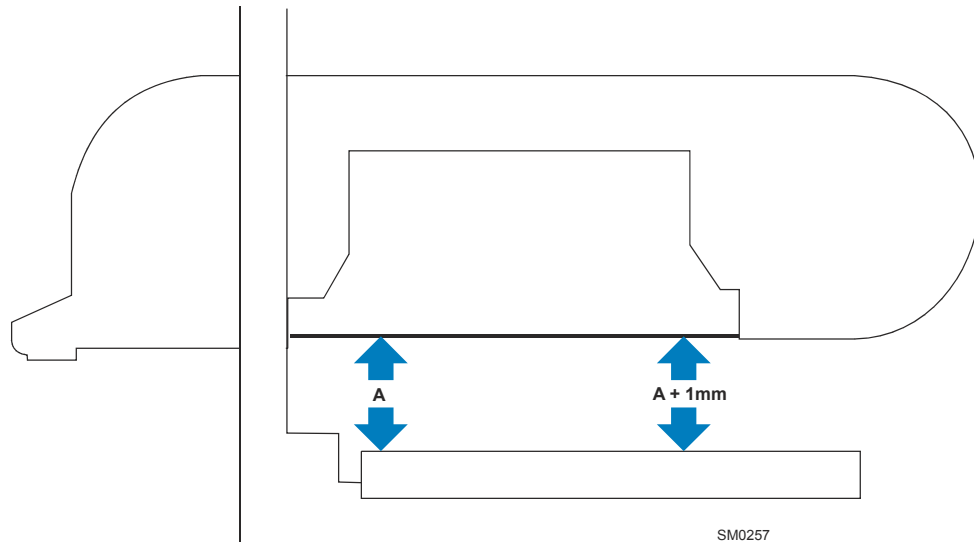

FIG. 7-43

2. Measure from the blade to the bed rail near the outer blade guide assembly. This measurement should be 1/16" (1.5 mm) higher than the inner measurement.

See Figure 7-44. To adjust the saw head tilt, use the bolts located at the bottom of the saw head mast. Loosen the three sets of four retaining plate bolts. To raise the outside of the saw head, back the stop bolts out, then tighten the adjustment bolts. To lower the outside of the saw head, loosen the adjustment bolts and tighten the stop bolts. Recheck the measurement from the blade to the bed rails and adjust the stop bolts and adjustment bolts until the outside of the saw head is 1/16" higher than the inside. Retighten the retaining plate bolts.

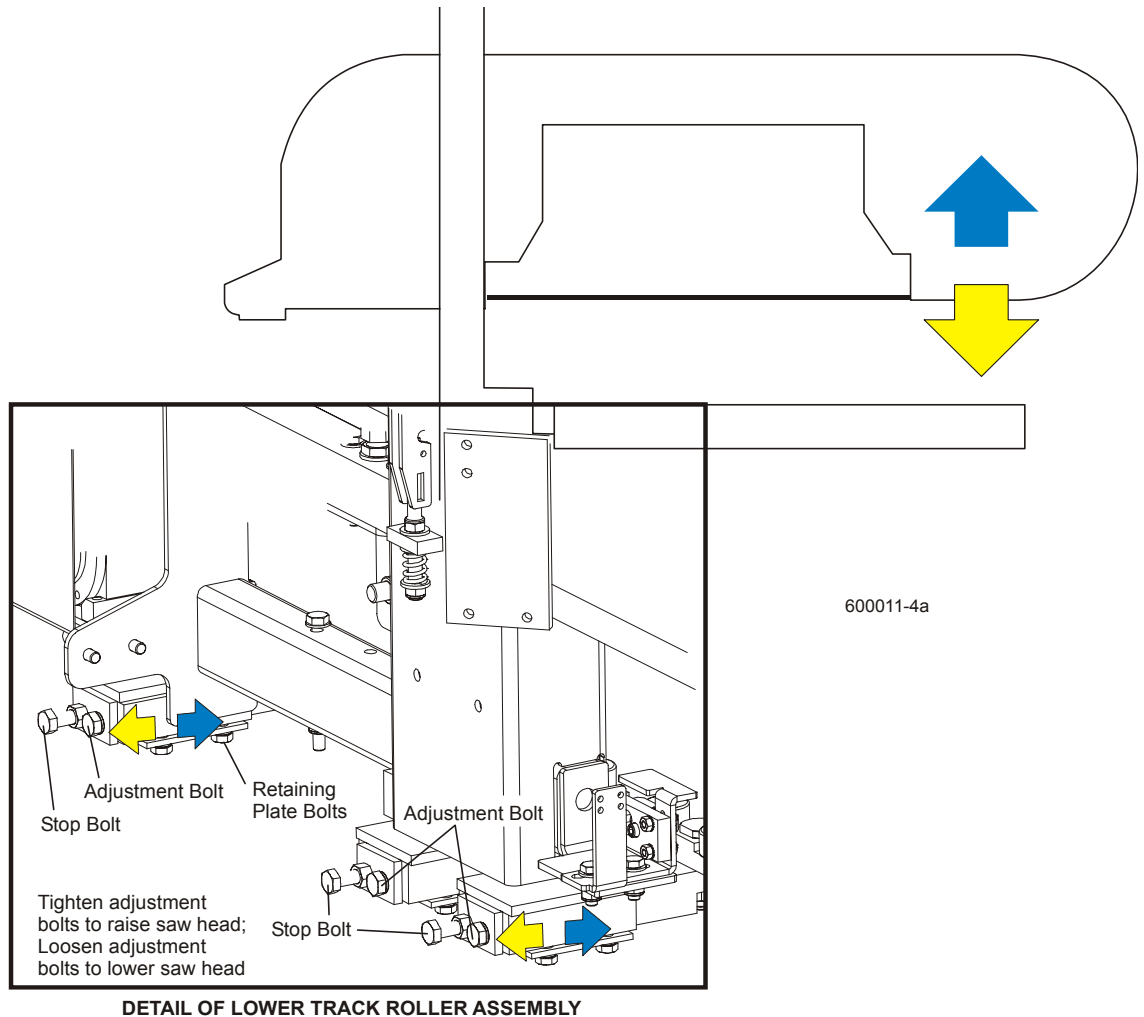

FIG. 7-44

Blade Height Scale Adjustment

After the entire sawmill has been aligned and all adjustments made, check that the blade height scale indicates the true distance from the blade to the bed rails.

1. Move the saw head so the blade is positioned directly above one of the bed rails. Measure from the bottom edge on a down-set tooth of the blade to the top of the bed rail, near the inner blade guide assembly.
2. View the blade height scale with eyes level with the indicator. The scale should indicate the actual distance from the blade to the bed rail. Adjust the indicator if necessary.

See Figure 7-45. Loosen the indicator bracket mounting bolts and adjust the bracket until the indicator is aligned with the correct mark on the scale. Retighten the bracket mounting nut.

For example, if the measurement from the down-set tooth of the blade to the bed rail was 14 3/4" (375 mm), make sure the indicator reads 14 3/4" (375 mm) on the scale.

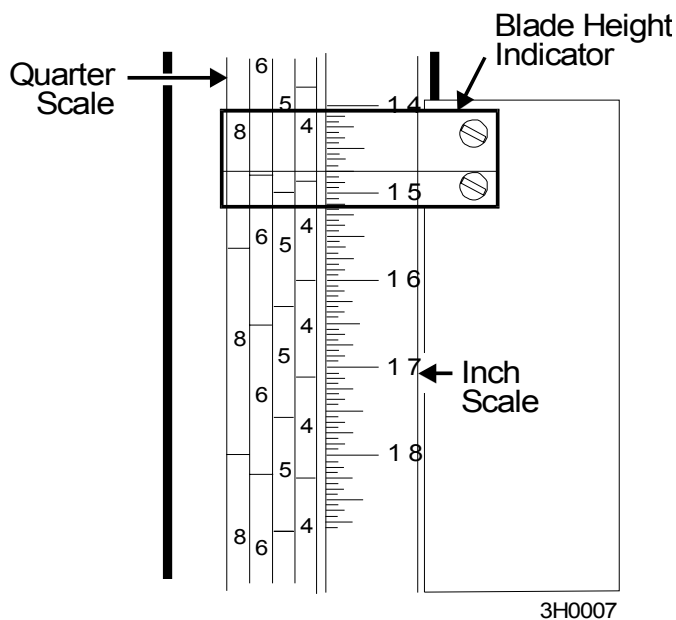

FIG. 7-45

SECTION 8 SPECIFICATIONS

8.1 Log Capacity

See Table 8-1. The LT70 Series Sawmills can accept logs as listed below.

	LT70S	LT70M	LT70L
Maximum Log Diameter	36,6" (93 cm)	36,6" (93 cm)	36,6" (93 cm)
Maximum Log Length ¹	15'-11" (4.9 m)	20'-2" (6.1 m)	27'-6" (8.4 m)
Maximum Log Weight ²	4400 lbs. (1996 kg)	4400 lbs. (1996 kg)	6614 lbs. (3000 kg)

TABLE 8-1

- ¹ Added length capacity provided with bed extension options. Add length of bed extension to sawmill length capacity (ie. BX12, add 12').
- ² Sawmills equipped with bed extensions can accept heavier logs if the weight is distributed so neither the sawmill or extension is loaded beyond the 4400 lbs. (1996 Kg) limit. Loading logs heavier than 4400 lbs. (1996 Kg) on a sawmill equipped with a bed extension requires auxiliary log handling equipment.

8.2 Overall Dimensions

See Table 8-1. The overall dimensions of the LT70L are listed below.

	LT70L
Length	10,8 m
Width	2,3 m
Height	2,3 m
Weight ¹	2780 kg.

TABLE 8-1

- ¹ Weight with optional trailer and heaviest engine option.

8.3 Engine/Motor Specifications

See Table 8-2. The power options available for the LT70 Series sawmills are listed below.

Engine/Motor Type ¹	Manufacturer	Model No.	Power	Other Specifications
42HP Diesel	Kubota, Japan	V1505-TE	42KM	4 cylinders, 1498 cm ³
25HP Electric Motor ²	Siemens, Germany	1LA7166-2AA60Z	18,5kW	33,8 A, 2930 RPM

TABLE 8-2

¹Use diesel fuel for D42.

²The electric motors supplied on Wood-Mizer sawmills carry a rating assigned by the motor manufacturer for the continuous duty operation of the motor, potentially, 24 hours per day, day after day. This rating is useful in sizing motors for use in applications like blowers for heating and ventilation that are never cycled off except for system maintenance.

See Table 8-3. Power Feed and Up/Down Systems for the LT70 Series sawmills are listed below.

Engine/Motor Type	Manufacturer	Voltage	Power	WM Part #
Power Feed Motor	Leeson, USA	12V	1800 RPM-600W	023688
Up/Down Motor	Leeson, USA	12V	1800 RPM-600W	015174
Blade Guide Arm Motor	Motor Products Owosso, USA	12V	60 RPM-17W	P09698-1
Hydraulic Pump Motor	Motor Products Owosso, USA	12V	2400 RPM-1320W	P09955

TABLE 8-3

Patrz tabela 8-4. The noise levels of the Wood-Mizer sawmills are listed below.¹²

Sawmill	Noise Level L _{EX8}
Sawmill Equipped With Electric Motor	83 dB (A)
Sawmill Equipped With Gas Engine	87,4 dB (A)

TABELA. 8-4

1. The noise level measurement was taken in accordance with PN-EN ISO 3746 Standard. The noise exposure level given above concerns an 8-hour work day

2.The measured values refer to emission levels, not necessarily to noise levels in the workplace. Although there is a relation between emission levels and exposure levels, it is not possible to determine with certainty if preventives are needed or are not needed. The factors affecting a current level of noise exposure during work are inter alia room characteristics and characteristics of other noise sources, e.g. number of machines and machining operations nearby. Also, the permissible exposure level value may vary depending on country. This information enables the machine's user to better identify hazards and a risk.

8.4 Chains

See Table 8-5. The load capacity of the chains is listed below.

Load Capacity According to ISO No 08A-1	
Power Feed Chain	22700N
Up/Down Chain	45400N

TABLE 8-5

8.5 Hydraulic System

See Table 8-6. The specifications of the hydraulic system are shown below.

Hydraulic Pump	#M-300-0230 Monarch
Pressure Rating	17,25MPa (2500 PSI)
Max. Pressure	19MPa (2750 PSI)

TABLE 8-6

8.6 Belt Sizes

See Table 8-7. Belt sizes for the LT70 Series sawmills are shown.

Description	Belt Size	Wood-Mizer Part #
Motor Drive Belt (E25)	3B/HB 2462La	089464
Engine Drive Belt (D42)	3B/HB 2462La	089464
Alternator Belt (DC mills only)	6PK775	089465
Up/Down Drive Belt	HA-630	090558
Blade Pulley Belts	B72.5 ¹	017922

TABLE 8-7

¹To insure proper blade tracking, use Goodyear, Dayco Super II, or Browning belts.

8.7 Hydraulic Blade Tensioner Schematic

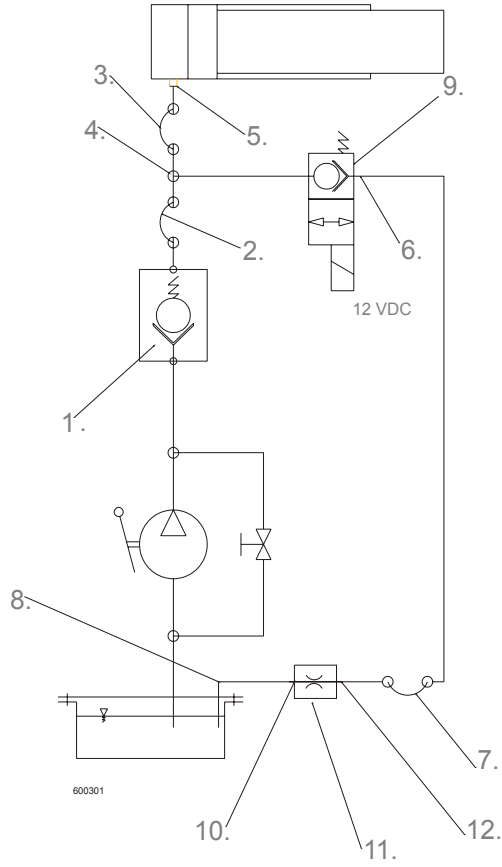

FIG. 8-1 HYDRAULIC SCHEMATIC.

8.8 Hydraulic Blade Tensioner Components

ID	Description
1	Non-return Valve HVR NW10MLED
2	Hose DN-12
3	Hose DN-12
4	T-Pipe DT RNW10HL
5	Connector VRNW10HL
6	Elbow W90HROKO6HJ04
7	Hose 1/4"
8	Elbow W90HROK04HJ
9	Valve ECP 20/22B2
10	Connector 4-4F642E DM XS
11	Throttle Valve VSG522.100000
12	Connector 4-4F42ED MXS

TABLE 8-8

8.9 Sawdust Extractor Specifications

See Table 8-9. The dust extractor specifications are given below.

Maximum Capacity	1200 m ³ /h
Collector Inlet Diameters (in front of fan)	150 MM.
Motor Power	1.5 kwh
Number of Sacks for Waste	1 pcs
Total Capacity of Sacks	0,25 m ³
Weight	110 kg
Conveying Speed When 10 m Long Hose Is Used	20 m/s

TABLE 8-9

SECTION 9 HYDRAULIC INFORMATION

9.1 LT70LDH Hydraulic Schematic

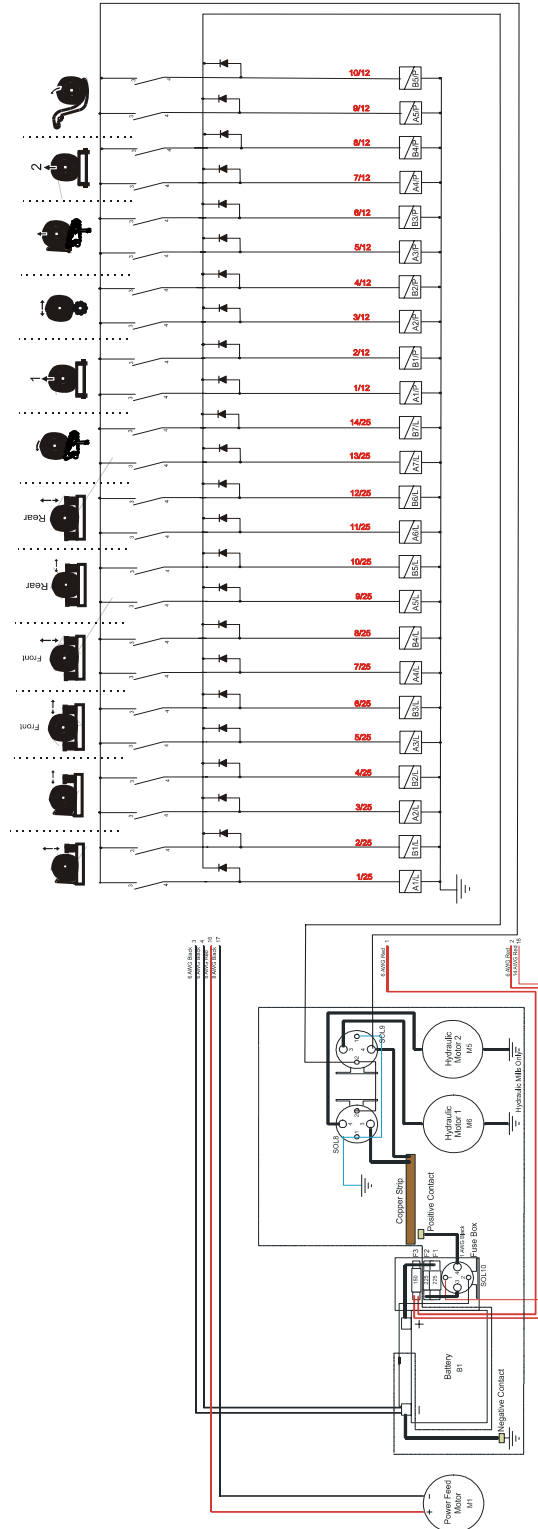

FIG. 9-1 HYDRAULIC SCHEMATIC.

9.2 LT70LDH Hydraulic Hoses

ID	Color Code	LENGTH "A"	Application	QTY.	Wood-Mizer Part No.
H1.	-	0,65m	Hose 3/8" Section Link	1	089844
H2.	Red	0,43m	Hose 3/8" Section To Oil Flow Divider.	1	089845
H3.	Orange	2,8m	Hose 3/8" Middle Log Clamp, IN/OUT Cylinder (Clamp OUT)	1	089846
H4.	White	3,0m	Hose 3/8" Middle Log Clamp, IN/OUT Cylinder (Clamp IN)	1	089847
H5.	None/Pink	5,4m	Hose 3/8" Side Support	2	089848
H6.	Brown/Lilac	4,1m	Hose 3/8" From Side Support Valve to 2nd Log Turner	2	089849
H7	Yellow	1,8m	Hose 3/8" 3rd Log Loader Cylinder (Single Loading Arm) Bottom To Oil Flow Divider	1	089850
H8	Blue	0,72m	Hose 3/8" Section Valve To 1st Tee Connector (Next To Log Turner).	1	089851
H9	Green/Yellow Green	1,2m	Hose 3/8" 3rd Tee Connector To 2nd Log Loader Cylinder Top/Bottom 3/8" 1ST Tee Connector To 3rd Log Loader Cylinder Top	3	089852
H10	Red	2,0m	Hose 3/8" Oil Flow Divider To 2nd Tee Connector	1	089853
H11	Yellow	2,1m	Hose 3/8" 2nd Tee Connector To 1st Log Loader Cylinder Bottom	1	089854
H12	Blue	1,6m	Hose 3/8" 1st Tee Connector To 3rd Tee Connector	1	089855
H13	Green	1,9m	Hose 3/8" 3rd Tee Connector to 1st Log Loader Cylinder Top	1	089856
H14		0,7m	Hose 1/4" DC Hydraulic Unit	1	089857
H15		0,25m	Hose 1/4" DC Hydraulic Unit	1	089858
H16	Lilac/Black	2,55m	Hose 1/4" 3rd Toe Board	2	089859
H17	Lilac/Black	0,85m	Hose 1/4" 2nd Toe Board	2	089860
H18	Brown/Silver	4,7m	Hose 1/4" 1st Toe Board	2	089861
H19	Yellow	3,85m	Hose 1/4" Middle Log Clamp, UP/DOWN Cylinder Bottom	1	089862
H20	Green	3,95m	Hose 1/4" Middle Log Clamp, UP/DOWN Cylinder Top	1	089863
H21	Orange	4,2m	Hose 1/4" 1st Log Clamp IN/OUT (Clamp OUT)	1	089864
H22	White	4,4m	Hose 1/4" Log Clamp IN/OUT (Clamp IN)	1	089865
H23	Blue/Red	4,9m	Hose 1/4" 1st Clamp Up/Down	2	089866
H24	White/Orange	2,7m	Hose 1/4" 3rd Clamp In/Out	2	089867

TABLE 9-1

9**Hydraulic Information***LT70LDH Hydraulic Hoses*

H25	Blue/Red	0,6m	Hose 1/4" 3rd Clamp Up/Down	2	089868
------------	----------	------	-----------------------------	---	--------

TABLE 9-1