

# **Wood-Mizer®**

## **Replacement Parts**

---

**EG100EH11S, EG100G14S rev. B1.00**

---



**Safety is our #1 concern!** Read and understand all safety information and instructions before operating, setting up or maintaining this machine.

*Form #1036*

# Table of Contents

# Section -Page

<b>SECTION 1</b>	<b>GENERAL INFORMATION</b>	<b>2-1</b>
1.1	How To Use The Parts List .....	2-1
1.2	Sample Assembly .....	2-1
<b>SECTION 2</b>	<b>TABLES</b>	<b>3-1</b>
2.1	Infeed Table .....	3-1
2.2	Drive Roller .....	3-3
2.3	Outfeed Table .....	3-4
2.4	Table Support .....	3-6
2.5	Additional Table (Option) .....	3-7
2.6	Infeed Table Hold-Down Wheel .....	3-8
2.7	Outfeed Table Hold-Down Wheel .....	3-9
<b>SECTION 3</b>	<b>ENGINE/MOTOR KITS</b>	<b>4-1</b>
3.1	EG100 E7S, E7, E11S, E11 Motor Kit .....	4-1
3.2	EG100G14S, EG100G14, G14U Engine Kits .....	4-4
<b>SECTION 4</b>	<b>MAIN MODULE</b>	<b>5-1</b>
4.1	Cutting Width Setting System .....	5-1
4.2	Movable Blade w/Mount Plate .....	5-3
4.3	Blade Position Lock Assembly .....	5-4
4.4	Blade Drive Belt Tensioner .....	5-5
4.5	Movable Blade Assembly .....	5-6
4.6	Table Drive Cover Assembly .....	5-7
4.7	Table Drive Cover Assembly (EG100 Edgers w/Adjustable Feed) .....	5-8
4.8	Table Drive Assembly .....	5-9
4.9	Table Drive Assembly (EG100 Edgers w/Adjustable Feed) .....	5-11
4.10	Chain Guide Sprocket .....	5-13
4.11	Chain Tensioner .....	5-14
4.12	Upper Blade Cover .....	5-15
4.13	Upper Blade Cover (Non CE Version) .....	5-17
4.14	Main Shaft & Fixed Blade (EG100 Edgers w/Adjustable Feed) .....	5-18
4.15	Fixed Blade & Main Shaft .....	5-20
4.16	Main Module Base .....	5-22
4.17	Sawdust Hopper .....	5-24
4.18	Main Module .....	5-25
<b>SECTION 5</b>	<b>EG100 EDGER DECALS</b>	<b>6-1</b>
5.1	Decals (EG100 Edgers w/Electric Motor) .....	6-2
5.2	Decals (EG100 Edgers w/gas Engine) .....	6-4

## SECTION 1 GENERAL INFORMATION

### 1.1 How To Use The Parts List

- Use the index above to locate the assembly that contains the part you need.
- Go to the appropriate section and locate the part in the illustration.
- Use the number pointing to the part to locate the correct part number and description in the table.
- Parts shown indented under another part are included with that part.

See the sample table below. Sample Part #A01111 includes part F02222-2 and subassembly A03333. Subassembly A03333 includes part S04444-4 and subassembly K05555. The diamond (◆) indicates that S04444-4 is not available except in subassembly A03333. Subassembly K05555 includes parts M06666 and F07777-77. The diamond (◆) indicates M06666 is not available except in subassembly K05555.

<b>1.2 Sample Assembly</b>				
REF	DESCRIPTION (◆ Indicates Parts Available In Assemblies Only)	PART #	QTY.	
	Sample Assembly, Complete (Includes All Indented Parts Below)	A01111	1	
1	Sample Part	F02222-22	1	
	Sample Subassembly (Includes All Indented Parts Below)	A03333	1	
2	Sample Part (◆ Indicates Part Is Only Available With A03333)	S04444-4	1	◆
	Sample Subassembly (Includes All Indented Parts Below)	K05555	1	
3	Sample Part (◆ Indicates Part Is Only Available With K05555)	M06666	2	◆
4	Sample Part	F07777-77	1	



**CAUTION!** It is strongly recommended that only original spare parts be used.

## SECTION 2 TABLES

### 2.1 Infeed Table

T00490\_001  
T00490\_MANUAL

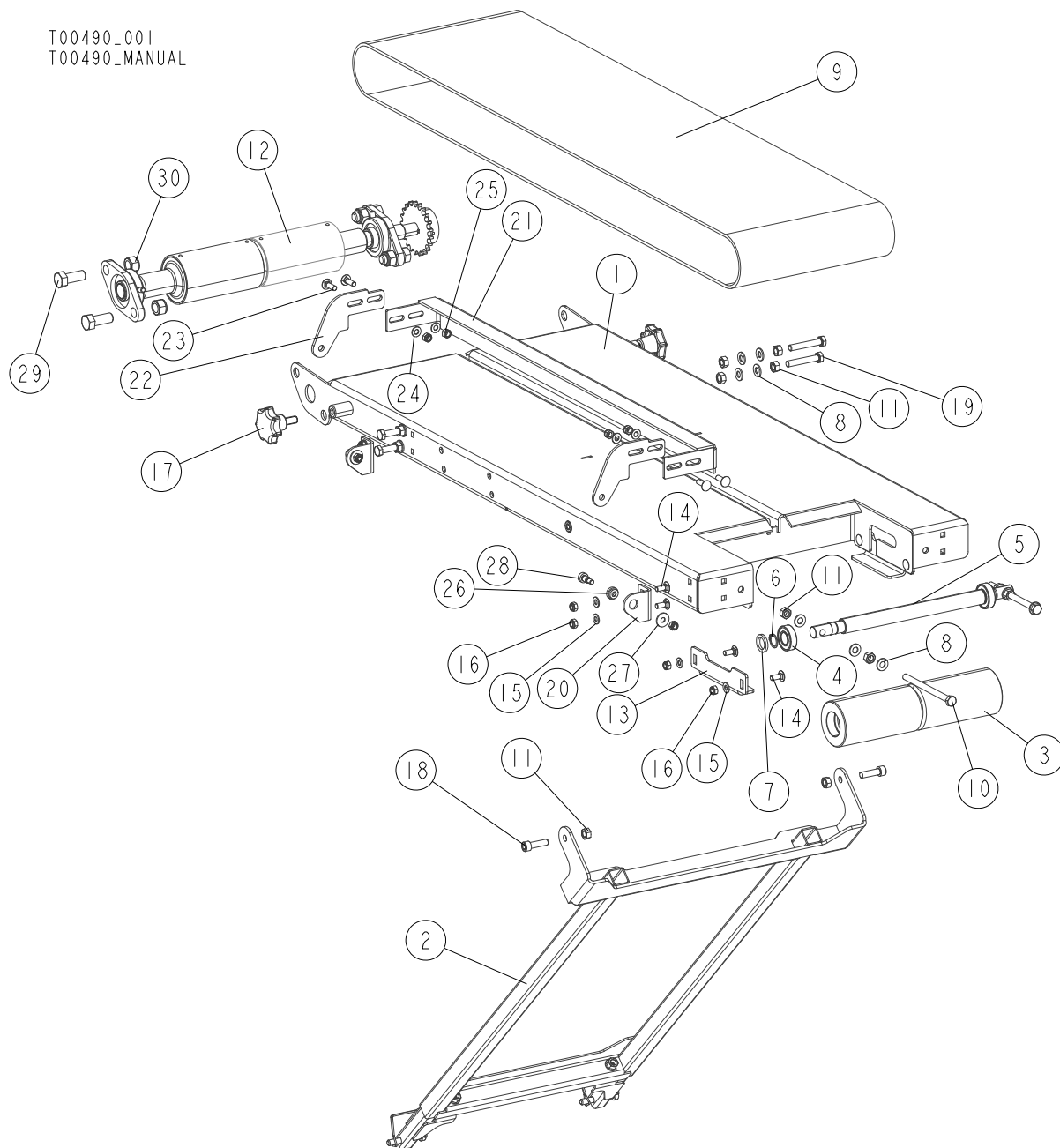

REF.	DESCRIPTION (* Indicates Parts Available in Assemblies Only)	PART#	QTY
-	<b>TABLE, INFEED - COMPLETE</b>	<b>T00490</b>	<b>1</b>
1	TABLETOP, INFEED TABLE	T00481-1	1
2	SUPPORT, TABLE - COMPLETE <a href="#">See Section 2.4</a>	T00446	1
-	<b>ROLLER, TENSION - COMPLETE</b>	<b>T00497</b>	<b>1</b>
3	ROLLER, TENSION	T00496	1
4	BEARING, 6004 2RS CX ROLLING	093868	2
5	SHAFT, TENSION ROLLER	T00495-1	1
6	RING, Z 20 OUTSIDE RETAINING	F81090-27	2
7	WASHER, 20.5X30-4 ZINC-PLATED	515021-1	2

REF.	DESCRIPTION (* Indicates Parts Available in Assemblies Only)	PART#	QTY	
8	WASHER, 10.5 FLAT ZINC	F81055-1	14	
9	BELT, TABLE	T00494	1	
10	BOLT, M10x140-8.8 HEX HEAD FULL THREAD ZINC	F81003-39	2	
11	NUT, M10 8 HEX ZINC	F81033-3	14	
12	ROLLER, DRIVE - COMPLETE <a href="#">See Section 2.2</a>	T00500	1	
13	ANGLE, SAFETY	T00501-1	2	
14	BOLT, M8x20-8.8 CARRIAGE ZINC	F81002-11	8	
15	WASHER, 8.4 FLAT ZINC	F81054-1	8	
16	NUT, M8-8-B HEX NYLON ZINC LOCK	F81032-2	10	
17	KNOB, SR1580 63x25M12 (462066 Moss)	500460	2	
18	SCREW, M10x35-8.8 HEX SOCKET HEAD CAP ZINC	F81003-56	2	
19	BOLT, M10X60-8.8 HEX HEAD ZINC	F81003-10	4	
20	BRACKET, BOARD GUIDE	T00508-1	2	
-	<b>GUIDE, BOARD</b>	<b>T00330</b>	<b>1</b>	
21	ANGLE, BOARD GUIDE	T00331-1	1	
22	ARM, BOARD GUIDE	T00332-1	2	
23	BOLT, M8x25-8.8 CARRIAGE ZINC	F81002-59	4	
24	WASHER, 8.4 FLAT ZINC	F81054-1	4	
25	NUT, M8-8-B HEX NYLON ZINC LOCK	F81032-2	4	
26	BUSHING, SHORT BOARD GUIDE	T00137-1	2	
27	WASHER, ISO 7093-1-8-200 HV-A2E	F81054-11	2	
28	BOLT, 10/M8X12-12.9 BOSSARD SHOULDER	F81003-62	2	
29	BOLT, M16X40-8.8 HEX HEAD FULL THREAD ZINC	F81006-13	4	
30	NUT, M16-8 HEX NYLON ZINC LOCK	F81036-2	4	

**2.2 Drive Roller**

T00500\_001  
T00500\_MANUAL

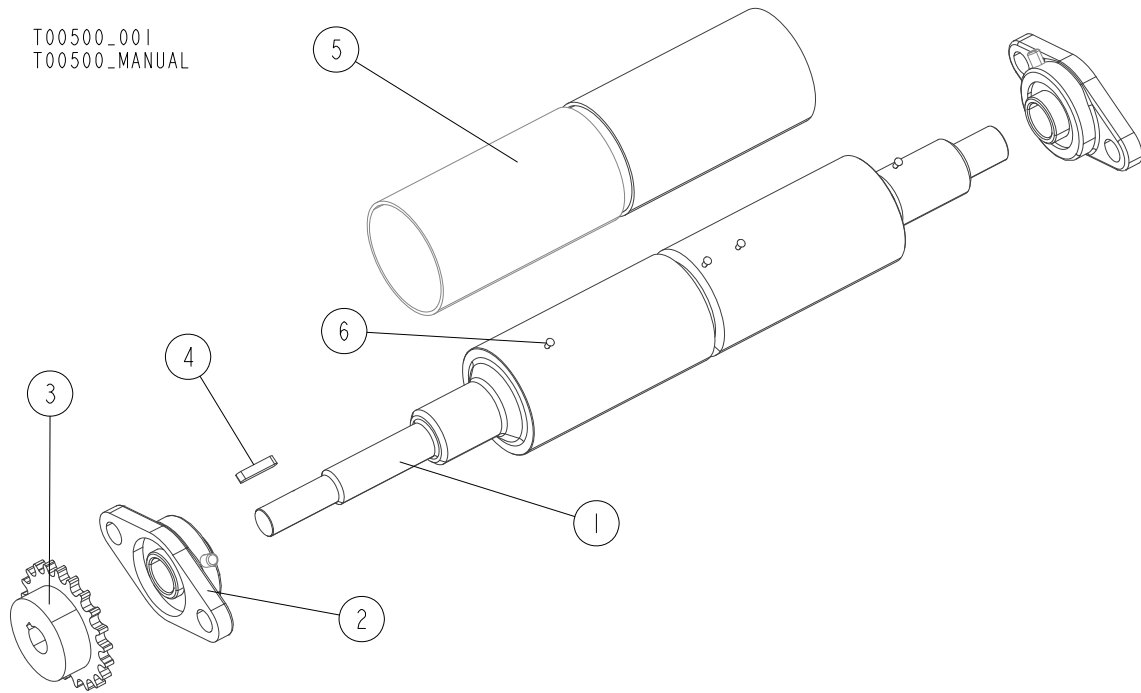

REF.	DESCRIPTION (* Indicates Parts Available in Assemblies Only)	PART#	QTY
-	<b>ROLLER, DRIVE - COMPLETE</b>	<b>T00500</b>	<b>1</b>
1	ROLLER, TABLE DRIVE	T00493-1	1
2	BEARING, UCFL205 W/HOUSING (COMPLEX)	089124	2
3	SPROCKET, 08B-1 Z21	T00160	1
4	KEY, A6x6x30	094245	1
5	LAGGING, 50MM PULLEY	R00100	1
6	RIVET, 3.2x7.4 ALUMINIUM	F81021-1	4

### 2.3 Outfeed Table

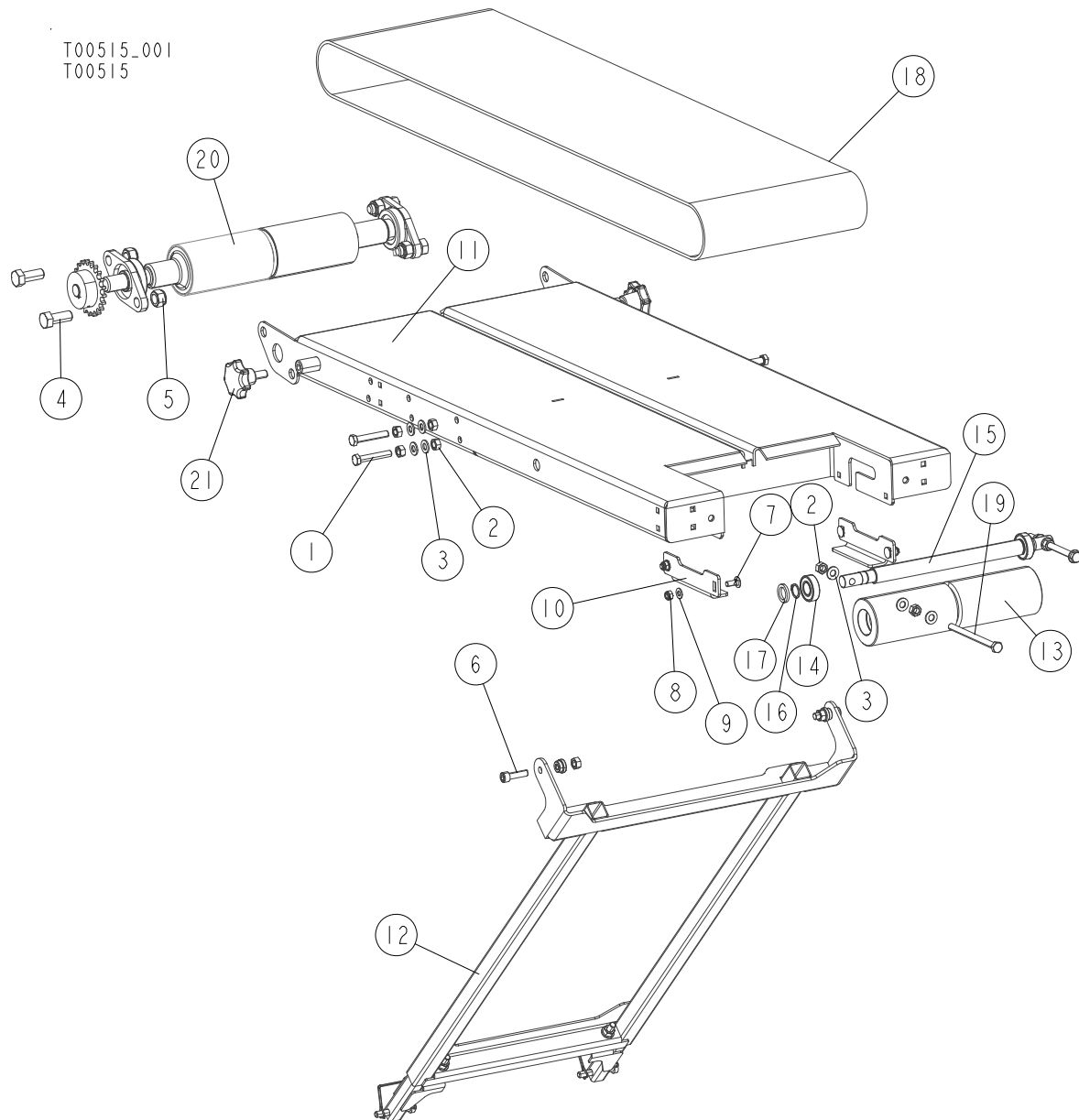

REF.	DESCRIPTION (* Indicates Parts Available in Assemblies Only)	PART#	QTY
-	<b>TABLE, OUTFEED - COMPLETE</b>	<b>T00515</b>	<b>1</b>
1	BOLT, M10X60-8.8 HEX HEAD ZINC	F81003-10	4
2	NUT, M10 8 HEX ZINC	F81033-3	14
3	WASHER, 10.5 FLAT ZINC	F81055-1	14
4	BOLT, M16x40-8.8 HEX HEAD FULL THREAD ZINC	F81006-13	4
5	NUT, M16-8 HEX NYLON ZINC LOCK	F81036-2	4
6	SCREW, M10x35-8.8 HEX SOCKET HEAD CAP ZINC	F81003-56	2
7	BOLT, M8x20-8.8 CARRIAGE ZINC	F81002-11	4
8	NUT, M8-8-B HEX NYLON ZINC LOCK	F81032-2	4
9	WASHER, 8.4 FLAT ZINC	F81054-1	4
10	ANGLE, SAFETY	T00501-1	2
11	TABLETOP	T00481-1	1
12	SUPPORT, TABLE - COMPLETE <a href="#">See Section 2.4</a>	T00446	1

## 2

## TABLES

## Outfeed Table

REF.	DESCRIPTION (* Indicates Parts Available in Assemblies Only)	PART#	QTY	
-	ROLLER, TENSION - COMPLETE	T00497	1	
13	ROLLER, TENSION	T00496	1	
14	BEARING, 6004 2RS CX ROLLING	093868	2	
15	SHAFT, TENSION ROLLER	T00495-1	1	
16	RING, Z 20 OUTSIDE RETAINING	F81090-27	2	
17	WASHER, 20.5X30-4 ZINC-PLATED	515021-1	2	
18	BELT, TABLE	T00494	1	
19	BOLT, M10x140-8.8 HEX HEAD FULL THREAD ZINC	F81003-39	2	
20	ROLLER, DRIVE - COMPLETE <a href="#">See Section 2.2</a>	T00500	1	
21	KNOB, SR1580 63x25M12 (462066 Moss)	500460	2	



## 2.4 Table Support

T00446\_001  
T00446\_MANUAL

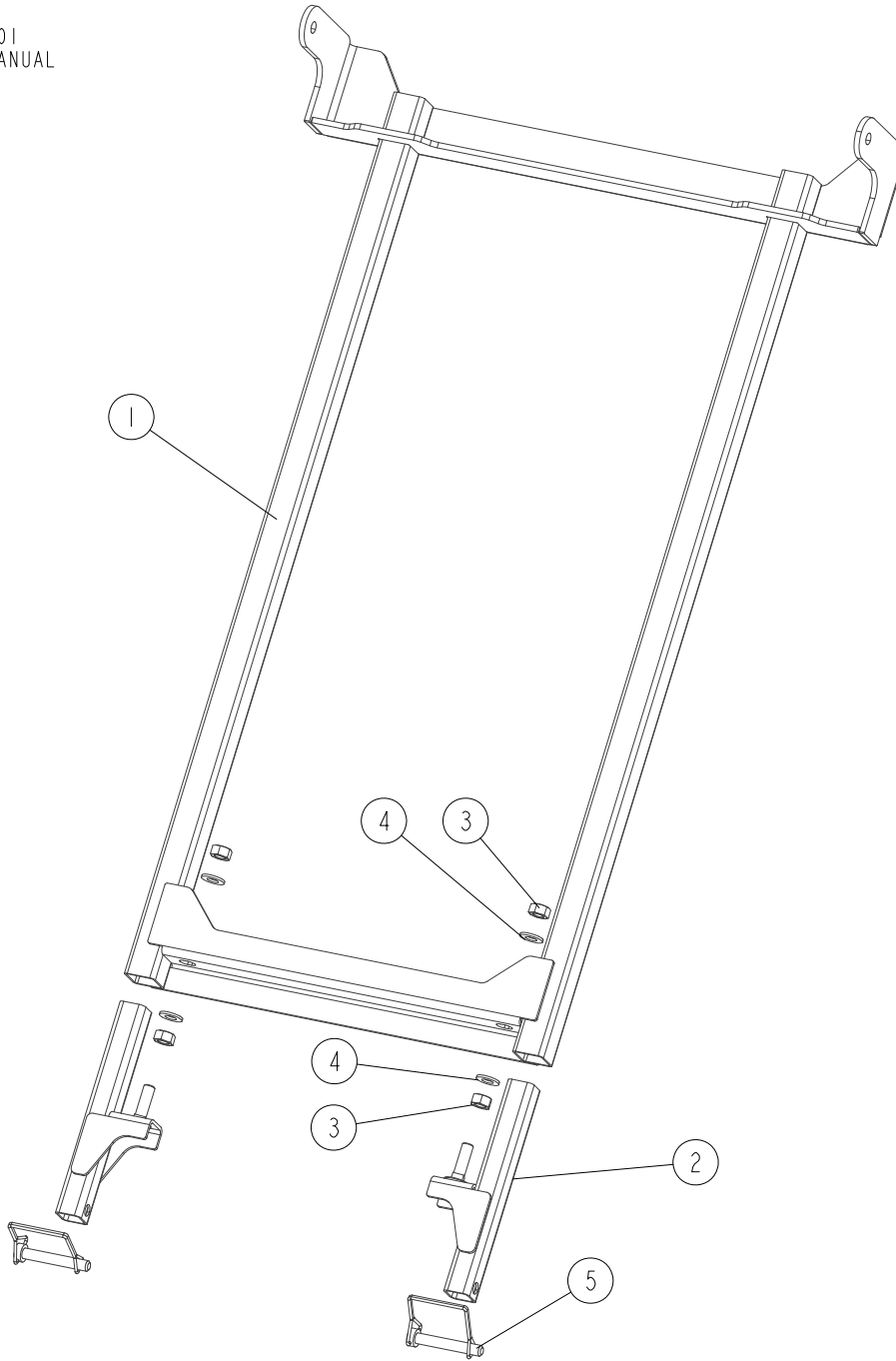

REF.	DESCRIPTION (* Indicates Parts Available in Assemblies Only)	PART#	QTY	
-	<b>SUPPORT, TABLE - COMPLETE</b>	<b>T00446</b>	<b>1</b>	
1	FRAME, TABLE SUPPORT	T00447-1	1	
2	TUBE, SUPPORT BASE	T00452-1	2	
3	NUT, M10 8 HEX ZINC	F81033-3	4	
4	WASHER, 10.5 FLAT ZINC	F81055-1	4	
5	PIN, 3/8X2 1/4 SQ WIRE LOCK	014151	2	

# 2 TABLES

## Additional Table (Option)

### 2.5 Additional Table (Option)

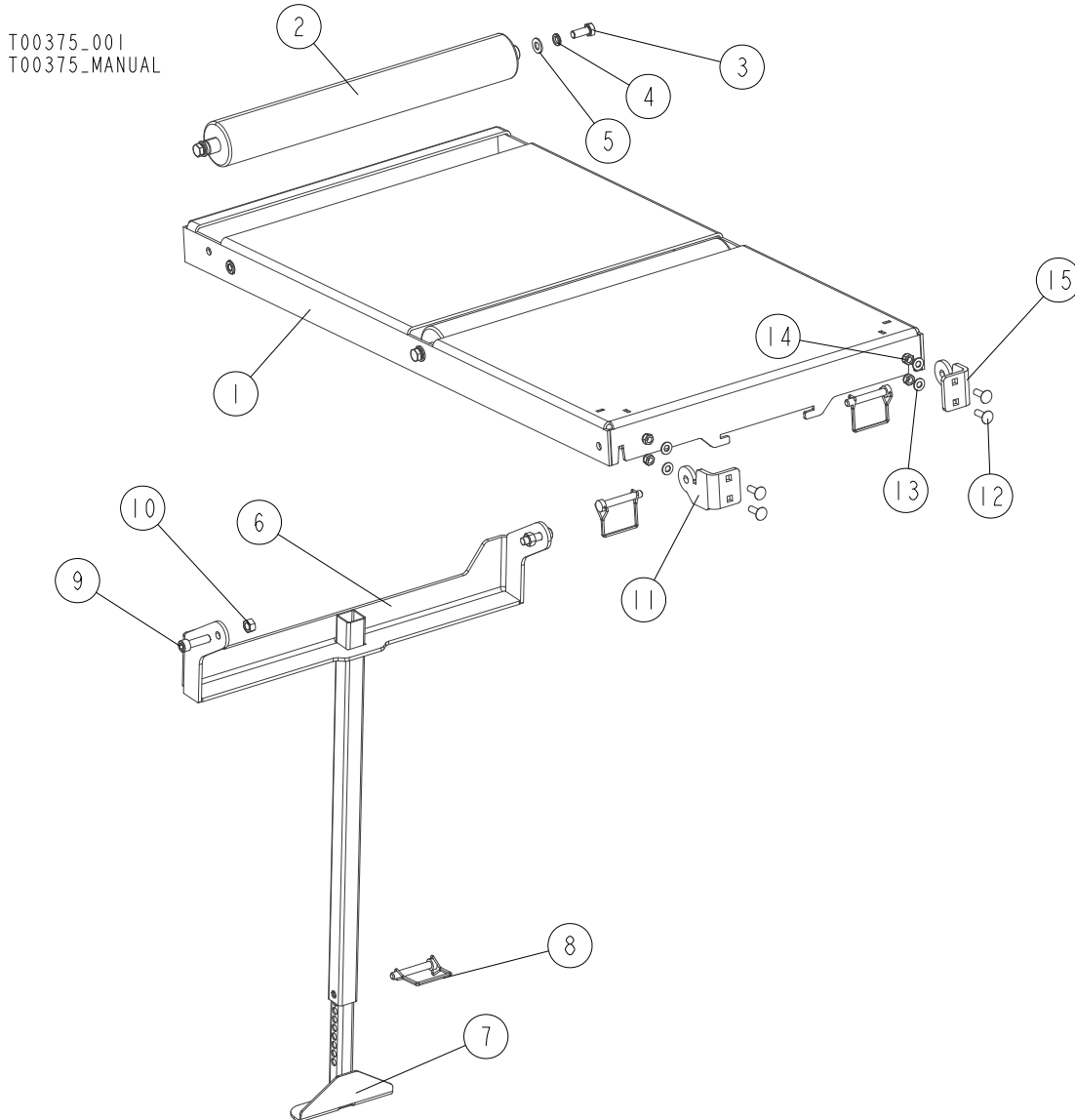

REF.	DESCRIPTION (* Indicates Parts Available in Assemblies Only)	PART#	QTY
-	<b>TABLE, ADDITIONAL</b>	<b>T00375</b>	<b>1</b>
1	TABLETOP, ADDITIONAL TABLE - COMPLETE	T00513-1	1
2	ROLLER, 63.5x480	T00136-1	2
3	BOLT, M10X25 8.8 HEX HEAD FULL THREAD ZINC	F81003-11	4
4	WASHER, Z 10.2 SPLIT LOCK ZINC	F81055-2	4
5	WASHER, 10.5 FLAT ZINC	F81055-1	4
6	BRACKET, TABLE SUPPORT UPPER	T00339-1	1
7	TUBE WELDMENT, TABLE SUPPORT LOWER	T00342-1	1
8	PIN, 3/8X2 1/4 SQ WIRE LOCK	014151	3
9	SCREW, M10x35-8.8 HEX SOCKET HEAD CAP ZINC	F81003-56	2
10	NUT, M10 8 HEX ZINC	F81033-3	2
11	BRACKET, TABLE - RIGHT	T00517-1	1
12	BOLT, M8X25-8.8 CARRIAGE ZINC	F81002-59	4
13	WASHER, 8.4 FLAT ZINC	F81054-1	4
14	NUT, M8-8-B HEX NYLON ZINC LOCK	F81032-2	4
15	BRACKET, TABLE - LEFT	T00503-1	1

2.6 Infeed Table Hold-Down Wheel

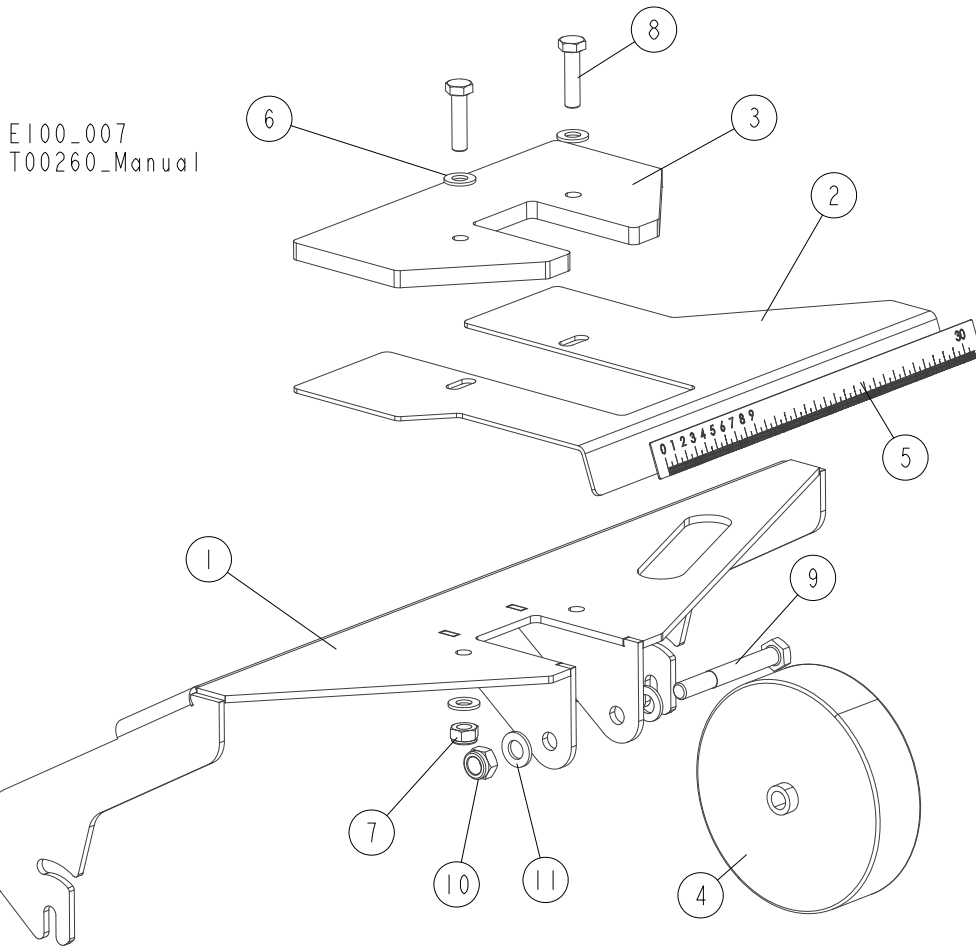

REF.	DESCRIPTION (* Indicates Parts Available in Assemblies Only)	PART#	QTY
	<b>WHEEL ASSEMBLY, HOLD-DOWN</b>	<b>T00319</b>	<b>1</b>
1	BRACKET, HOLD-DOWN WHEEL MOUNT	T00333-1	1
2	BRACKET, INFEEED TABLE SCALE	T00336-1	1
3	PLATE, TOP	T00337-1	1
4	WHEEL-HOLD-DOWN	T00161	1
5	SCALE, INFEEED TABLE	T00320	1
	SCALE, INFEEED TABLE, INCH	T00398	1
6	WASHER, 10.5 FLAT ZINC	F81055-1	4
7	NUT, M10-8-B HEX NYLON ZINC LOCK	F81033-1	2
8	BOLT, M10X40-8.8 HEX HEAD FULL THREAD ZINC	F81003-16	2
9	BOLT, M12X95 8.8 HEX HEAD ZINC	F81004-29	1
10	NUT, M12 8 HEX NYLON ZINC LOCK	F81034-2	1
11	WASHER, 13 FLAT ZINC	F81056-1	2

**2.7 Outfeed Table Hold-Down Wheel**

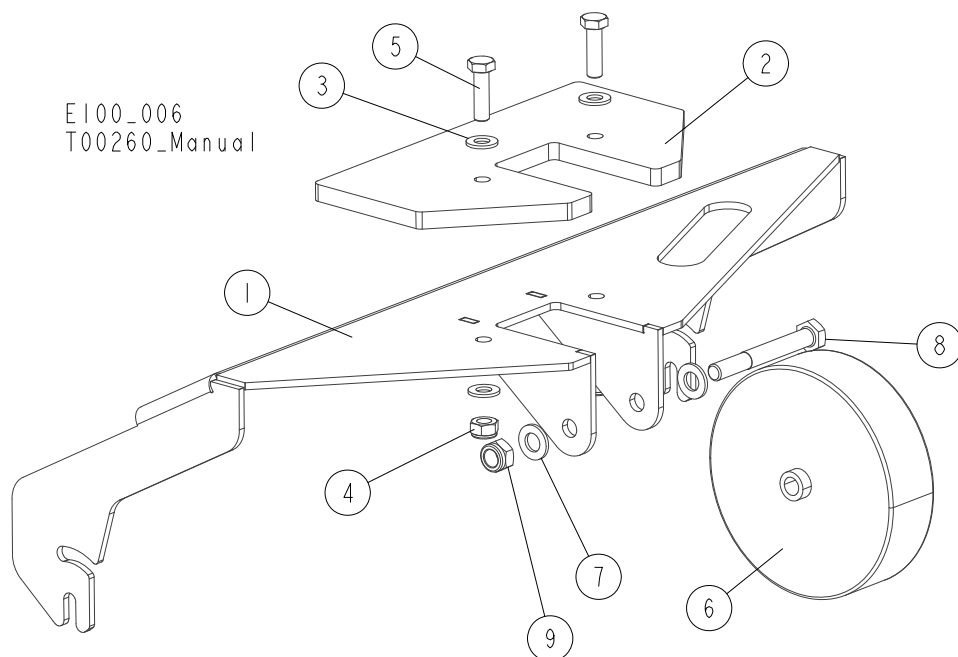

REF.	DESCRIPTION (* Indicates Parts Available in Assemblies Only)	PART#	QTY
	<b>WHEEL ASSEMBLY, HOLD-DOWN</b>	<b>T00345</b>	<b>1</b>
1	BRACKET, HOLD-DOWN WHEEL MOUNT	T00333-1	1
2	PLATE, TOP	T00337-1	1
3	WASHER, 10.5 FLAT ZINC	F81055-1	4
4	NUT, M10-8-B HEX NYLON ZINC LOCK	F81033-1	2
5	BOLT, M10X35 8.8 HEX HEAD FULL THREAD ZINC	F81003-17	2
6	WHEEL, HOLD-DOWN	T00161	1
7	WASHER, 13 FLAT ZINC	F81056-1	2
8	BOLT, M12X95 8.8 HEX HEAD ZINC	F81004-29	1
9	NUT, M12 8 HEX NYLON ZINC LOCK	F81034-2	1

## SECTION 3 ENGINE/MOTOR KITS

### 3.1 EG100 E7S, E7, E11S, E11 Motor Kit

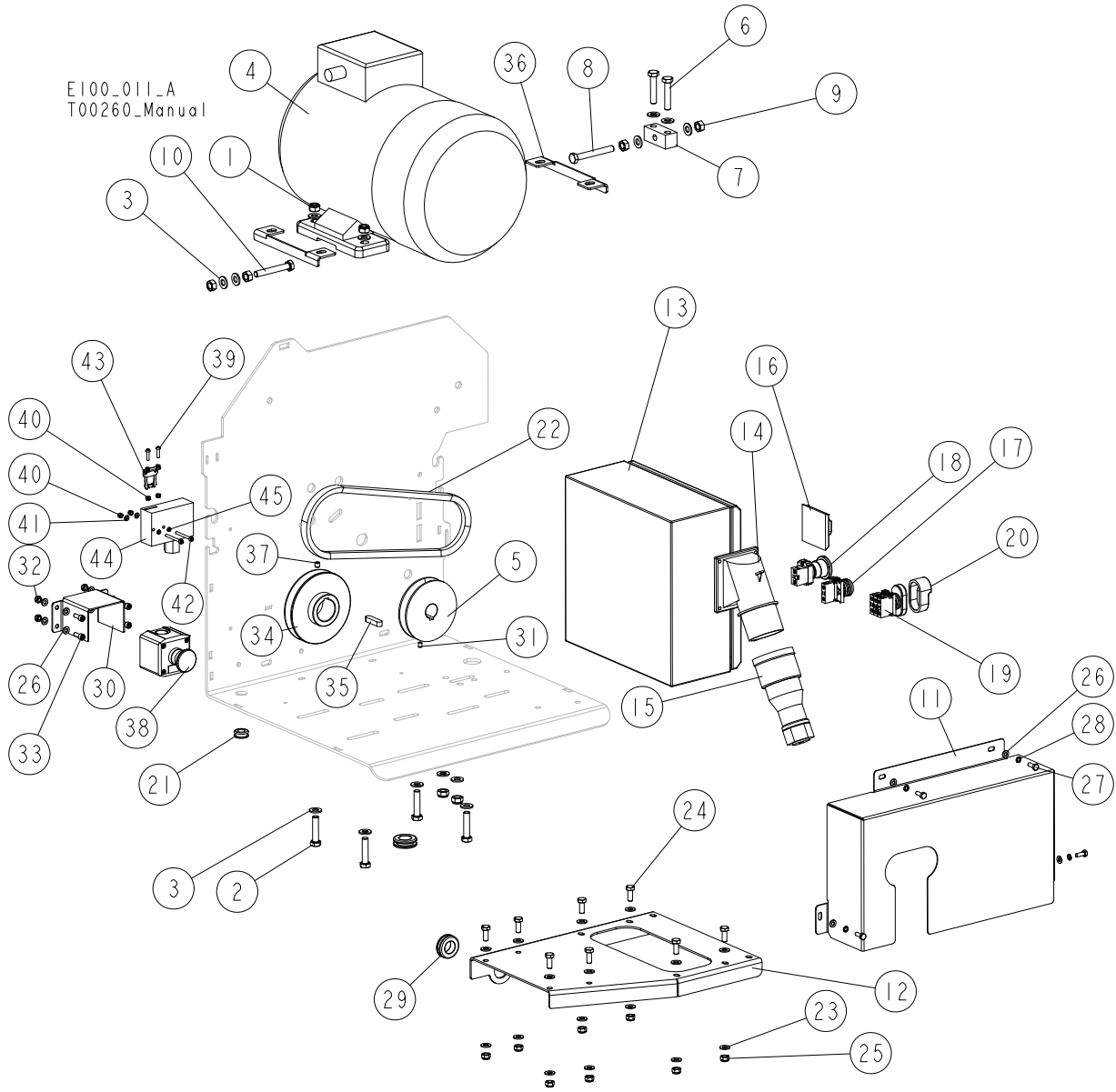

REF.	DESCRIPTION (◆ Indicates Parts Available in Assemblies Only)	PART#	QTY
	MOTOR KIT, EG100 EH7S	T00520	1
	MOTOR KIT, EG100 EH7	T00520-3	1
	MOTOR KIT, EG100 EH11S	T00565	1
	MOTOR KIT, EG100 EH11	T00565-3	1
	MOTOR KIT, EG100 EC11U	T00565-4	1
	MOTOR KIT, EG100 E11U	T00565-4U	1
	MOTOR KIT, EG100 EB11U	T00565-5	1
	MOTOR KIT, EG100 E11U	T00565-5U	1
	MOTOR KIT, EG100 EA11U	T00565-6	1
	MOTOR KIT, EG100 EA11U	T00565-6U	1
1	NUT, M10-8-B HEX NYLON ZINC LOCK	F81033-1	6
2	BOLT, M10X45 HEX HEAD FULL THREAD ZINC	F81003-3	4

REF.	DESCRIPTION (◆ Indicates Parts Available in Assemblies Only)	PART#	QTY
3	WASHER, 10.5 FLAT ZINC	F81055-1	16
4	MOTOR, 7.5kW 1LE1002-1CA13-4AA4Z-B16 400V/690 50Hz S6 60%	085482 <sup>1</sup>	1
	MOTOR, 7.5kW 1LE1002-1CA13-4AA4Z-B16 400V/690 50Hz S6 60%	085482-2 <sup>2</sup>	1
	MOTOR, 7.5kW 1LE1002-1CA13-4AA4Z-B16 400V/690 50Hz S6 60%	095785 <sup>3</sup>	1
	MOTOR, 7.5kW 1LE1002-1CA13-4AA4Z-B16 400V/690 50Hz S6 60%	053790 <sup>4</sup>	1
5	PULLEY, 16X108	T00282-1	1
6	BOLT, M10x50-8.8 HEX HEAD FULL THREAD ZINC	F81003-4	2
7	BLOCK, TENSIONER	T00283-1	1
8	BOLT, M10X80 8.8 HEX HEAD FULL THREAD ZINC	F81003-76	1
9	NUT, M10 8 HEX ZINC	F81033-3	4
10	BOLT, M10X70 8.8 HEX HEAD FULL THREAD ZINC	F81003-20	1
11	GUARD, DRIVE - COMPLETE (ELECTRICAL VERSION)	T00186-1	1
12	PLATE, ELECTRIC BOX MOUNT	T00213-1	1
	<b>BOX, EG100 EH7S ELECTRIC</b>	<b>T00521</b>	<b>1</b>
	<b>BOX, EG100 EH7 ELECTRIC</b>	<b>T00521-3</b>	<b>1</b>
	<b>BOX, EG100 EH11S ELECTRIC</b>	<b>T00566</b>	<b>1</b>
	<b>BOX, EG100 EH11 ELECTRIC</b>	<b>T00566-3</b>	<b>1</b>
	<b>BOX, EG100 EC11U ELECTRIC</b>	<b>T00566-4</b>	<b>1</b>
	<b>BOX, EG100 EB11U ELECTRIC</b>	<b>T00566-5</b>	<b>1</b>
	<b>BOX, EG100 EA11S ELECTRIC</b>	<b>T00566-6</b>	<b>1</b>
13	BOX, SAREL S83002/300x300x150	092627	1
14	PLUG, 16A 5P 778152-6 PCE	E85239	1
15	SOCKET, 16A 5P 2152-6TT PCE	E85240	1
16	HANDLE, OHB S2A1 AB SWITCH	502312-1	1
17	LIGHT, M22 LED 24V BLUE CONTROL	090448	1
18	BUTTON, XB4 BS542 EMERGENCY STOP	086556	1
19	SWITCH, 24V MOELLER ILLUMINATED START/STOP	090452	1
20	DIAPHRAGM, M22-T-DD MOELLER	090462	1
21	GROMMET, 20/13 RUBBER	086188	1
22	BELT, HB 775 Li -820 Lw	T00322	1
23	WASHER, 8.4 FLAT ZINC	F81054-1	16
24	BOLT, M8X20 5.8 HEX HEAD FULL THREAD ZINC	F81002-1	8
25	NUT, M8 8 HEX NYLON ZINC LOCK	F81032-2	8
26	WASHER, 6.4 FLAT ZINC	F81053-1	12
27	BOLT, M6x16-8.8 HEX HEAD FULL THREAD ZINC	F81001-15	4
28	WASHER, Z 6.1 SPLIT LOCK ZINC	F81053-3	4
29	GROMMET, 22mm I.D. RUBBER	087400	2
30	GUARD, EMERGENCY STOP BUTTON	T00211-1	1
31	SCREW, M6x8-33H-GEOMET HEX SOCKET SET W/CONE POINT	F81013-1	1
32	NUT, M6-8-B HEX NYLON ZINC LOCK	F81031-2	4
33	SCREW, M6x16 8.8 HEX SOCKET HEAD CAP ZINC	F81001-21	4
34	PULLEY, E11 MOTOR	086807-1	1
35	KEY, A10x8x40 PARRALEL	502045	1
36	BRACKET, MOTOR	100760-1	2
37	SCREW, M8X8-33H GEOMET HEX SOCKET SET W/FLAT POINT	F81014-1	1

REF.	DESCRIPTION (◆ Indicates Parts Available in Assemblies Only)	PART#	QTY
38	BUTTON, XALK 174 EMERGENCY STOP	E22703-P	1
39	SCREW, M4x16 5.8-B CROSS RECESSED PAN HEAD ZINC	F81011-42	2
40	NUT, M4-8 HEX NYLON ZINC LOCK	F81029-1	4
41	WASHER, 4.3 FLAT ZINC	F81051-2	2
42	SCREW, M4x40 8.8 HEX SOCKET HEAD CAP ZINC	F81011-37	2
43	KEY, AZ17/170-B5	094422	1
44	INTERLOCK, AZM170-11 SOLENOID	095831	1
45	WASHER, Z 4.1 SPLIT LOCK ZINC	F81051-1	3

<sup>1</sup> Belongs to EG100 E11/E11S/E11U

<sup>2</sup> Belongs to EG100EB11U

<sup>3</sup> Belongs to EG100 E7/E7S

<sup>4</sup> Belongs to EG100 EA11U

**3.2 EG100G14S, EG100G14, G14U Engine Kits**

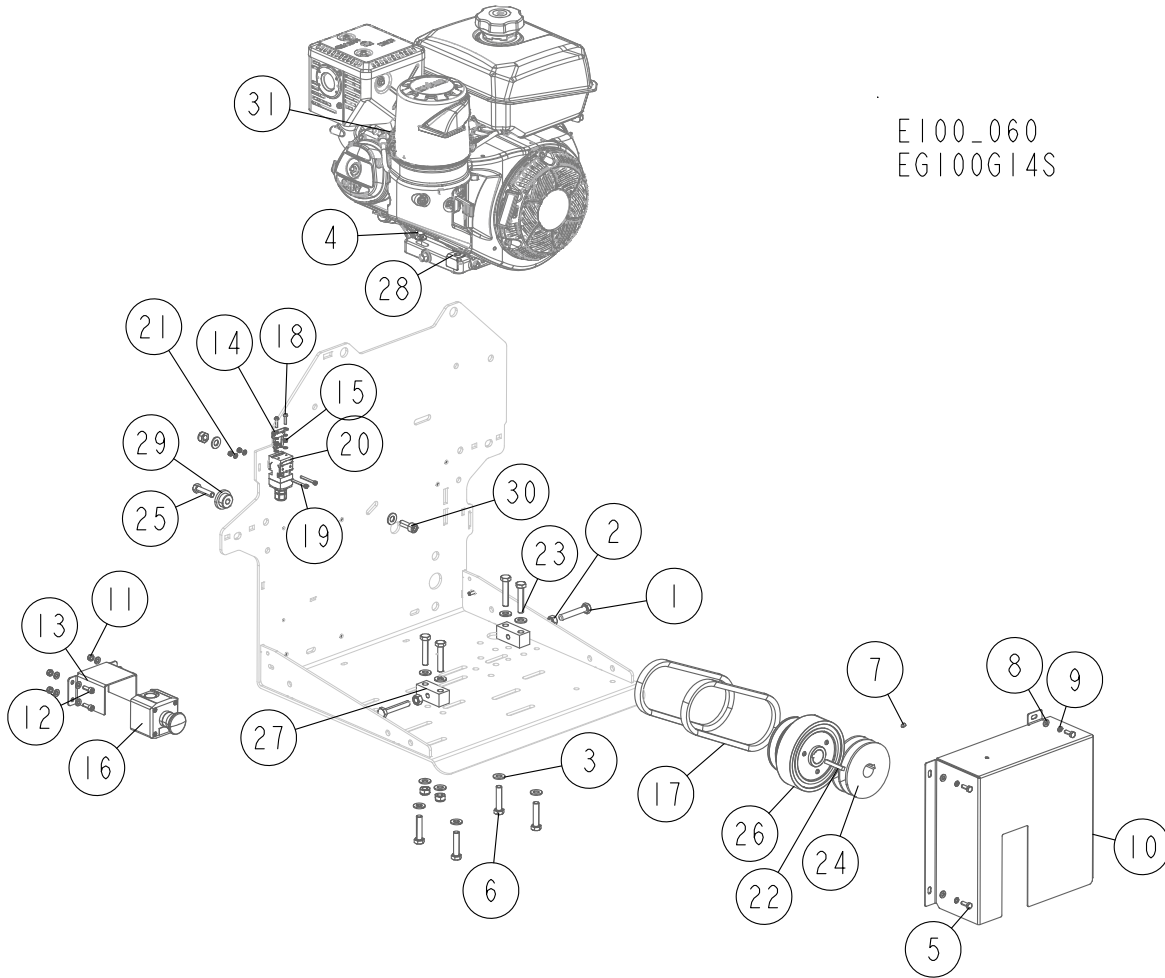

REF.	DESCRIPTION (◆ Indicates Parts Available in Assemblies Only)	PART#	QTY
	<b>ENGINE KIT, EG100 G14S</b>	T00661	1
	<b>ENGINE KIT, EG100 G14, G14U</b>	T00661-3	1
	<b>ENGINE KIT, EG100GU</b>	T00661-3U	1
1	BOLT, M10X60-8.8 HEX HEAD FULL THREAD ZINC	F81003-140	4
2	NUT, M10-8-B-HEX ZINC	F81033-3	10
3	WASHER, 10,5 FLAT ZINC	F81055-1	1
4	NUT, M10-8-B HEX NYLON ZINC LOCK	F81033-1	1
5	BOLT, M6x16 8.8 HEX HEAD FULL THREAD ZINC	F81001-15	1
6	BOLT, M10x45-8.8-HEX HEAD FULL THREAD ZINC	F81003-3	1
7	SCREW, M6x8 45H GEOMET HEX SOCKET SET W/FLAT POINT	F81013-1	2
8	WASHER, 6,4 FLAT ZINC	F81053-1	1
9	WASHER, Z 6,1 SPLIT LOCK ZINC	F81053-3	1
10	GUARD, ENGINE DRIVE	T00657-1	1
11	NUT, M6-8-B-HEX NYLON ZINC LOCK	F81031-2	1
12	SCREW, M6x16 -8.8- HEX SOCKET HEAD CAP ZINC	F81001-21	2
13	GUARD, EMERGENCY STOP BUTTON E100 PTD.	T00211-1	2
14	KEY, AZ17/170-B5 SAFETY SWITCH	094422	1



REF.	DESCRIPTION (◆ Indicates Parts Available in Assemblies Only)	PART#	QTY
15	NUT, M4-B HEX NYLON ZINC LOCK	F81029-1	2
16	BUTTON, XALK 178 EMERGENCY STOP	E22703-P	2
17	BELT, DAYCO 7188 15,2 x 596 Le DRIVE	T00346	1
18	SCREW, M4x16 5,8-B CROSS RECESSED PAN HEAD ZINC	F81011-42	1
19	SCREW, M4x35 -8.8- HEX SOCKET HEAD CAP ZINC	F81011-34	1
20	SWITCH, AZ17-11ZRK SAFETY	094232	3
21	WASHER, 4,3 FLAT ZINC	F81051-2	1
22	KEY, 6,35 x 6,36 x 40	092601	2
23	BOLT, M10x50-8.8-HEX HEAD FULL THREAD ZINC	F81003-4	2
24	PULLEY, 2X15,4X108	T00655-1	1
25	BOLT, 3/8-24X1 1/2 HH Gr8 Yzc	F05007-143	1
26	CLUTCH, NORAM 180009 CENTRIFUGAL	T00654	1
	SPRING	T00665	1
	LINING, CLUTCH	T00666	4
	HUB ASSEMBLY	T00667	1
	PULLEY, W/DRUM	T00668	5
	BUSHING, 6007-2RS	096955	1
	RING, W62 RETAINING	F81090-1	1
	RING, Z35 RETAINING	F81090-36	12
27	BLOCK, TENSIONER THREADED	T00660-1	4
28	PLATE, ENGINE TRAY SECURING	T00659-1	1
29	WASHER, CLUTCH ZINC	T00656-1	4
30	SCREW, M10x25 8.8 HEX SOCKET HEAD CAP ZINC	F81003-32	4
31	ENGINE, KOHLER G14 (CH440-3149)	X200-1201	4

SECTION 4 MAIN MODULE

4.1 Cutting Width Setting System

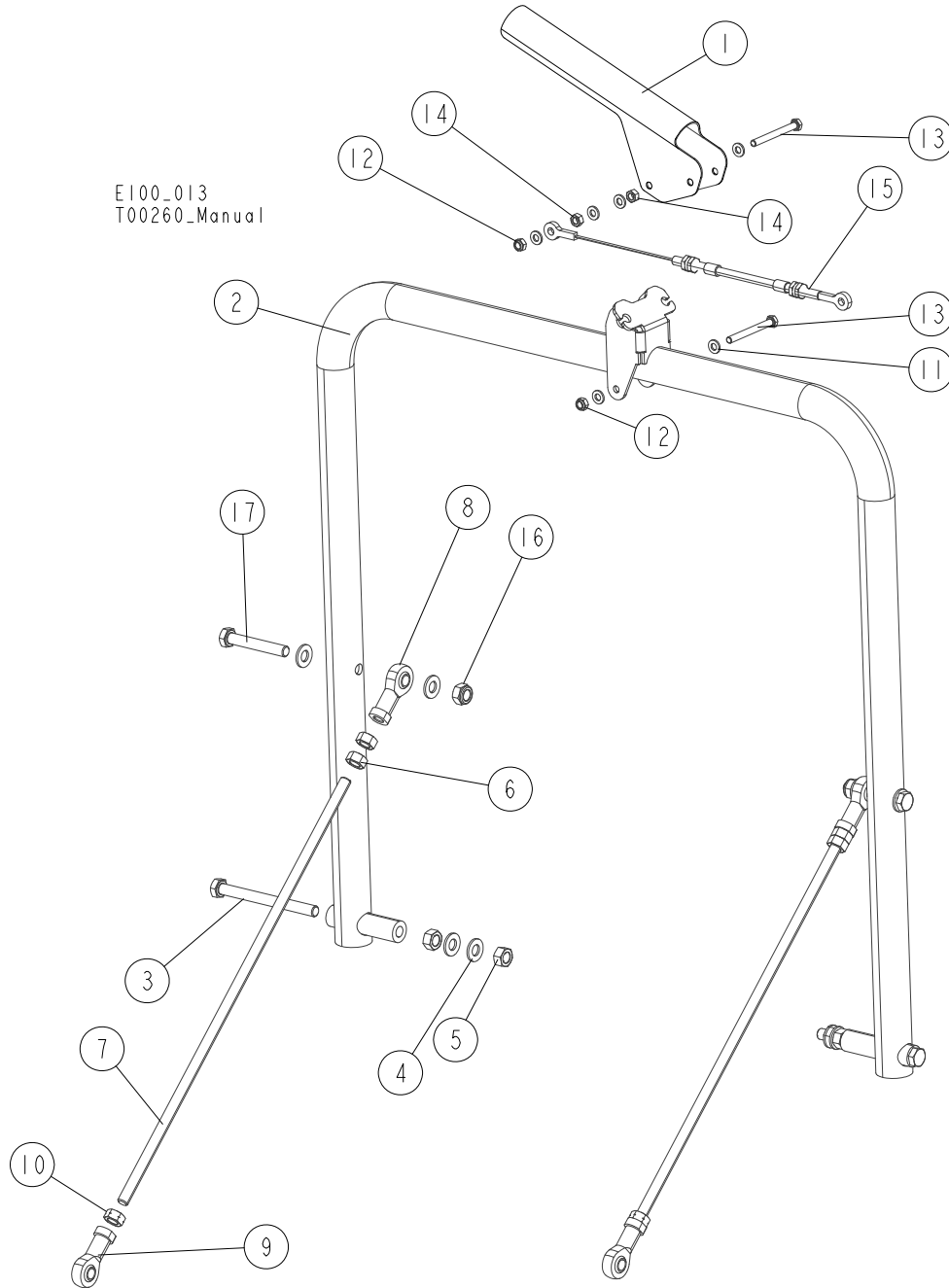

REF.	DESCRIPTION (◆ Indicates Parts Available in Assemblies Only)	PART#	QTY
	<b>CUTTING WIDTH SETTING SYSTEM</b>	<b>T00127</b>	<b>1</b>
1	LEVER, CABLE	516929-1	1
2	LEVER WELDMENT, CUTTING WIDTH SETTING	T00128-1	1
3	BOLT, M10X110-8.8 HEX HEAD ZINC	F81003-43	2
4	WASHER, 10.5 FLAT ZINC	F81055-1	8
5	NUT, M10 8 HEX ZINC	F81033-3	4
	<b>LINK, COMPLETE</b>	<b>T00250</b>	<b>1</b>
6	NUT, M10 8 HEX ZINC	F81033-3	2

REF.	DESCRIPTION (◆ Indicates Parts Available in Assemblies Only)	PART#	QTY	
7	ROD, LINK	T00249-1	1	
8	END, SI10 CX LINK	T00245	1	
9	END, SIL10 CX LINK	T00241	1	
10	NUT, M10LH 8 HEX LEFT ZINC	F81033-12	1	
11	WASHER, 6.4 FLAT ZINC	F81053-1	6	
12	NUT, M6-8-B HEX NYLON ZINC LOCK	F81031-2	2	
13	BOLT, M6X60-8.8 HEX HEAD FULL THREAD ZINC	F81001-9	2	
14	NUT, M6 8 HEX ZINC	F81031-1	2	
15	CABLE, PAWL	T00235	1	
16	NUT, M10-8-B HEX NYLON ZINC LOCK	F81033-1	2	
17	BOLT, M10X65-8.8 HEX HEAD ZINC	F81003-67	2	

4.2 Movable Blade w/Mount Plate

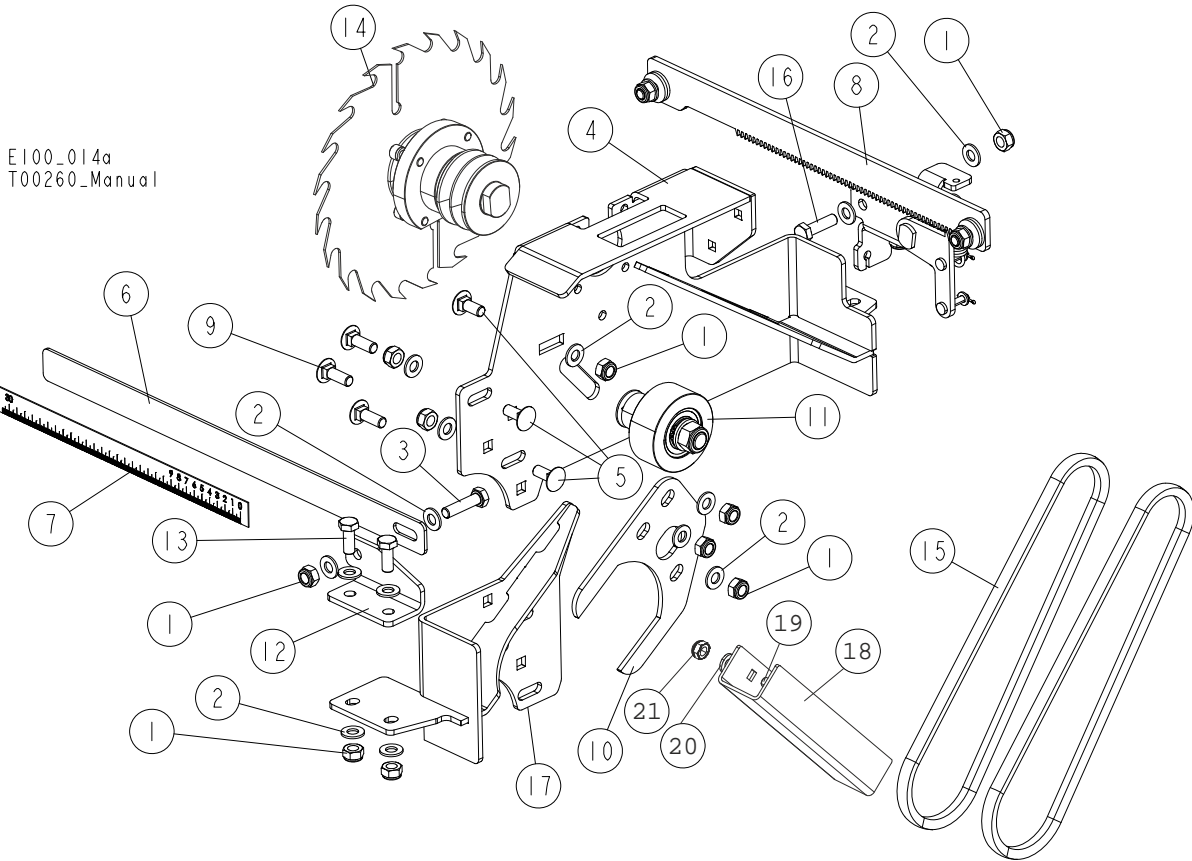

E100\_014a  
T00260\_Manual

REF.	DESCRIPTION (◆ Indicates Parts Available in Assemblies Only)	PART#	QTY
	<b>PLATE ASSEMBLY, MOVABLE</b>	<b>T00251</b>	<b>1</b>
1	NUT, M10-8-B HEX NYLON ZINC LOCK	F81033-1	10
2	WASHER, 10.5 FLAT ZINC	F81055-1	14
3	BOLT, M10X40-8.8 HEX HEAD FULL THREAD ZINC	F81003-16	1
4	PLATE, MOVABLE BLADE - COMPLETE	T00200-1	1
5	BOLT, M10X25-8.8 CARRIAGE ZINC	F81003-59	3
	<b>COMPLETE SCALE</b>	<b>T00325</b>	<b>1</b>
6	PLATE, BLADE SCALE ZINC-PLATED	T00324-1	1
7	SCALE, BLADE	T00321	1
	SCALE, BLADE, INCH	T00399	1
8	LOCK ASSEMBLY, BLADE POSITION <a href="#">See Section 4.3</a>	T00246	1
9	BOLT, M10X30-8.8 CARRIAGE ZINC	F81003-101	3
10	FORK, MOVABLE BUSHING ZINC-PLATED	T00199-1	1
11	TENSIONER, BLADE DRIVE BELT <a href="#">See Section 4.4</a>	T00522	1
12	ANGLE, MOVABLE PLATE ZINC-PLATED	T00253-1	1
13	BOLT, M10X25 8.8 HEX HEAD FULL THREAD ZINC	F81003-11	2
14	BLADE ASSEMBLY, MOVABLE <a href="#">See Section 4.5</a>	T00546	1
15	BELT, AVX 13 x 830 La.	T00269	2
16	BOLT, M10X35 8.8 HEX HEAD FULL THREAD ZINC	F81003-17	1
17	BRACKET WELDMENT, MOVABLE BLADE PLATE	T00203-1	1
18	GUIDE, SAWDUST	T00662-1	1
19	BOLT, M6x16-8.8 CARRIAGE ZINC	F81001-36	2
20	WASHER, M6, FLAT,ZINC	F81053-1	2
21	NUT,M6-8-B HEX,NYLON LOCK ZINC	F81031-2	2

### 4.3 Blade Position Lock Assembly

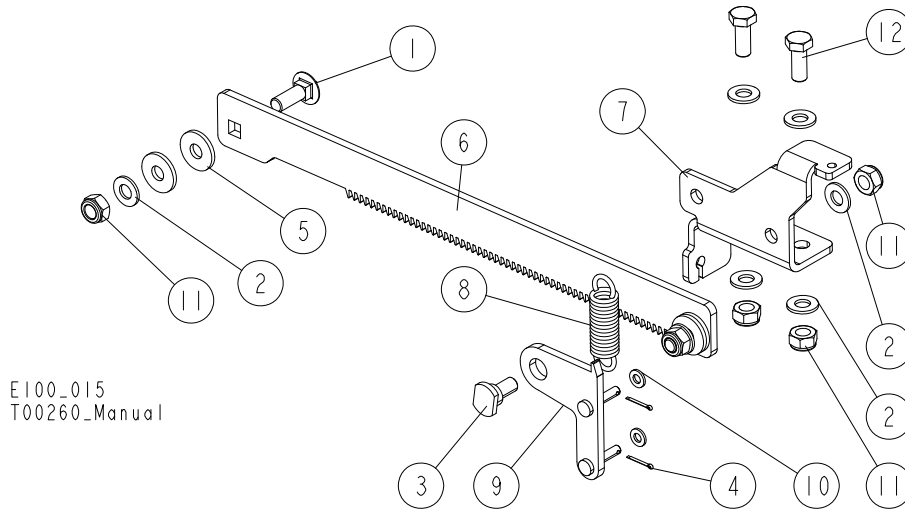

REF.	DESCRIPTION (◆ Indicates Parts Available in Assemblies Only )	PART#	QTY
	<b>LOCK ASSEMBLY, BLADE POSITION</b>	<b>T00246</b>	<b>1</b>
1	BOLT, M10X30-8.8 CARRIAGE ZINC	F81003-101	2
2	WASHER, 10.5 FLAT ZINC	F81055-1	7
3	PIN	T00212-1	1
4	PIN, ISO 1234-2X16-ST-A2 COTTER	F81041-2	2
5	WASHER, 10.5 SPECIAL FLAT ZINC	F81055-6	4
6	PLATE, BLADE SETTING ZINC-PLATED	T00326-1	1
	PLATE, BLADE SETTING ZINC-PLATED, INCH	T00620-1	1
7	BRACKET, PAWL ZINC-PLATED	T00328-1	1
8	SPRING, 3/4x2 7/8x12Ga	015479	1
9	PAWL, ZINC-PLATED - COMPLETE	T00268-1	1
10	WASHER, 6.4 FLAT ZINC	F81053-1	2
11	NUT, M10-8-B HEX NYLON ZINC LOCK	F81033-1	5
12	BOLT, M10X25 8.8 HEX HEAD FULL THREAD ZINC	F81003-11	2

# 4

## Main Module

### Blade Drive Belt Tensioner

#### 4.4 Blade Drive Belt Tensioner

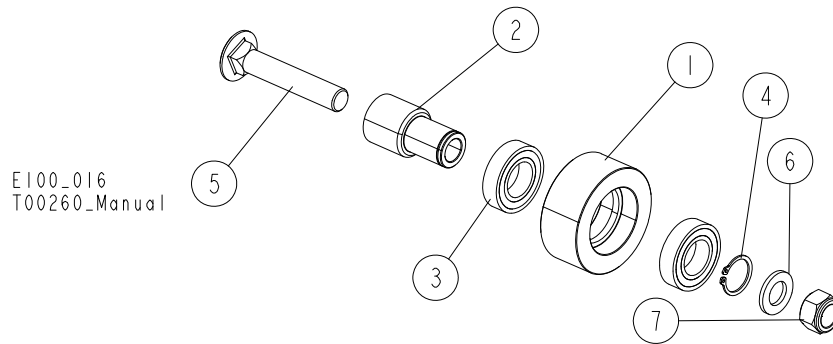

REF.	DESCRIPTION (◆ Indicates Parts Available in Assemblies Only)	PART#	QTY
	<b>TENSIONER, BLADE DRIVE BELT</b>	T00522	1
1	ROLLER, BELT TENSIONER	T00524	1
2	BUSHING, TENSIONER ROLLER ZINC-PLATED	T00523-1	1
3	BEARING, 6005 2RS PN-85/M-86100	089652	2
4	RING, 25Z OUTSIDE RETAINING	F81090-22	1
5	BOLT, M16X110 8.8 CARRIAGE ZINC	F81006-71	1
6	WASHER, 17 SPLIT LOCK ZINC	F81058-1	1
7	NUT, M16-8 HEX NYLON ZINC LOCK	F81036-2	1

## 4.5 Movable Blade Assembly

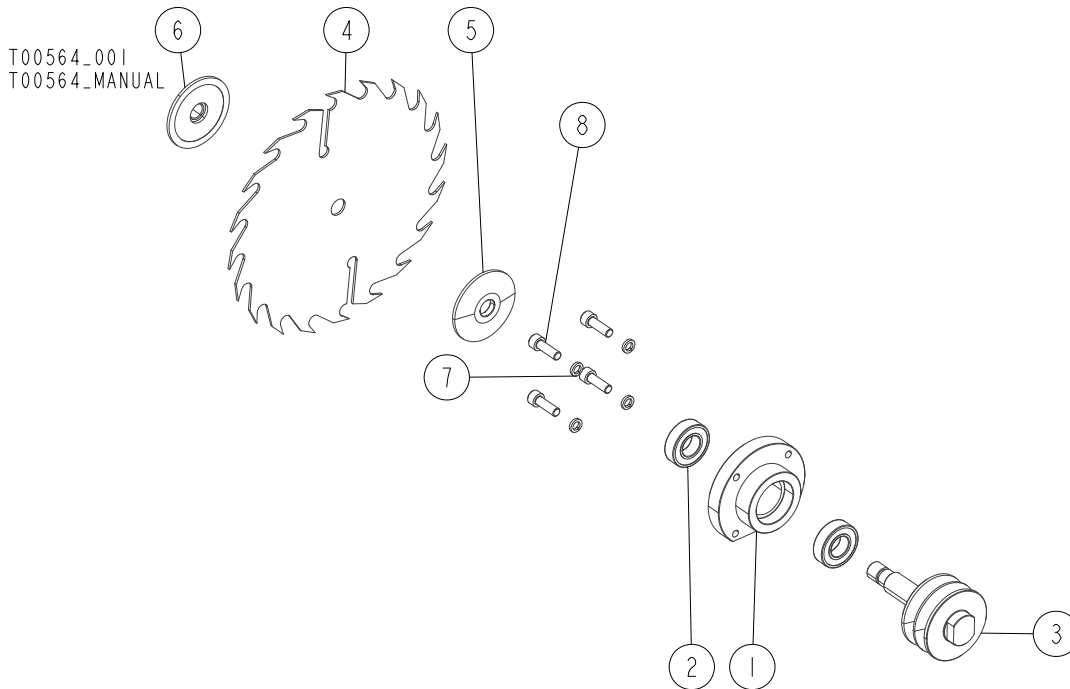

REF.	DESCRIPTION (◆ Indicates Parts Available in Assemblies Only)	PART#	QTY
-	<b>BLADE ASSEMBLY, MOVABLE</b>	<b>T00546</b>	<b>1</b>
1	SLEEVE, BLADE BEARING	T00547-1	1
2	BEARING, 6004 2RS CX ROLLING	093868	2
3	SHAFT, MOVABLE BLADE	T00518-1	1
4	BLADE, CIRCULAR	T00168	1
5	DISC, BLADE MOUNTING	T00263-1	1
6	NUT, MOVABLE BLADE	T00264-1	1
7	WASHER, 8.2 SPLIT LOCK ZINC	F81054-4	4
8	SCREW, M8X25 8.8 HEX SOCKET HEAD CAP ZINC	F81002-21	4

4.6 Table Drive Cover Assembly

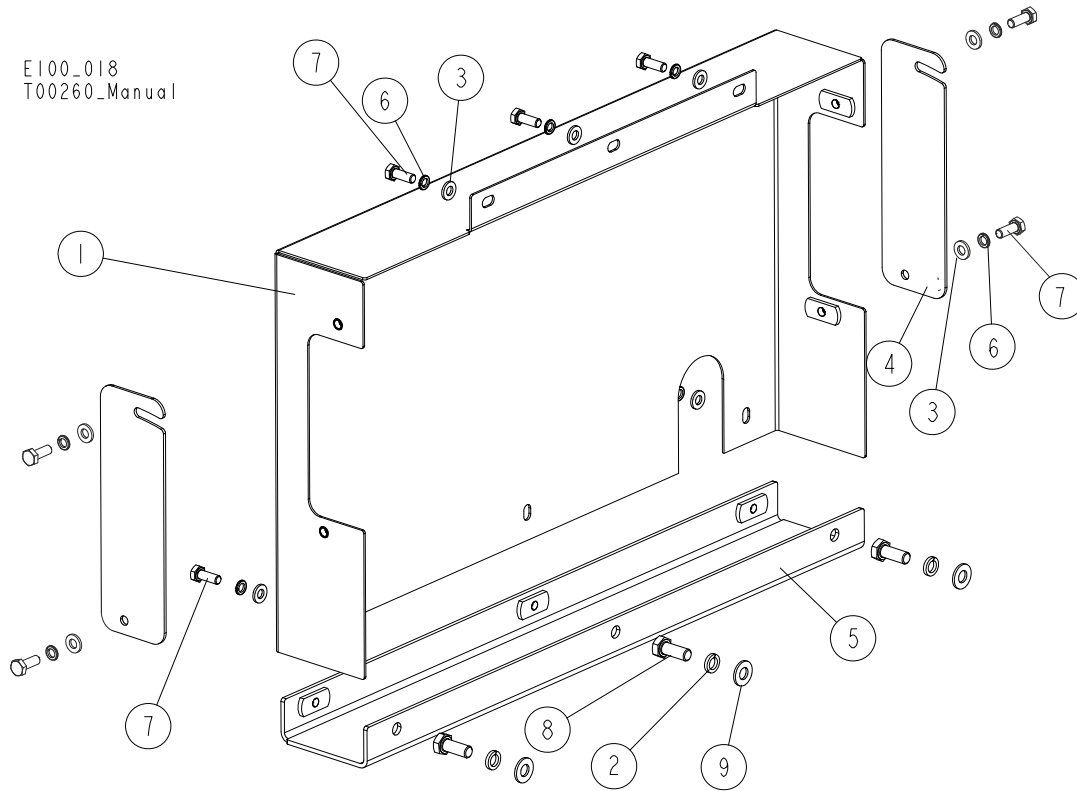

REF.	DESCRIPTION (◆ Indicates Parts Available in Assemblies Only)	PART#	QTY
	<b>COVER ASSEMBLY, TABLE DRIVE</b>	<b>T00228</b>	<b>1</b>
1	COVER WELDMENT, TABLE DRIVE	T00229-1	1
2	WASHER, 8.2 SPLIT LOCK ZINC	F81054-4	3
3	WASHER, 6.4 FLAT ZINC	F81053-1	10
4	PLATE, COVER	T00231-1	2
5	BRACKET WELDMENT, COVER	T00232-1	1
6	WASHER, Z 6.1 SPLIT LOCK ZINC	F81053-3	10
7	BOLT, M6X16-8.8 HEX HEAD FULL THREAD ZINC	F81001-15	10
8	BOLT, M8X20 5.8 HEX HEAD FULL THREAD ZINC	F81002-1	3
9	WASHER, 8.4 FLAT ZINC	F81054-1	3

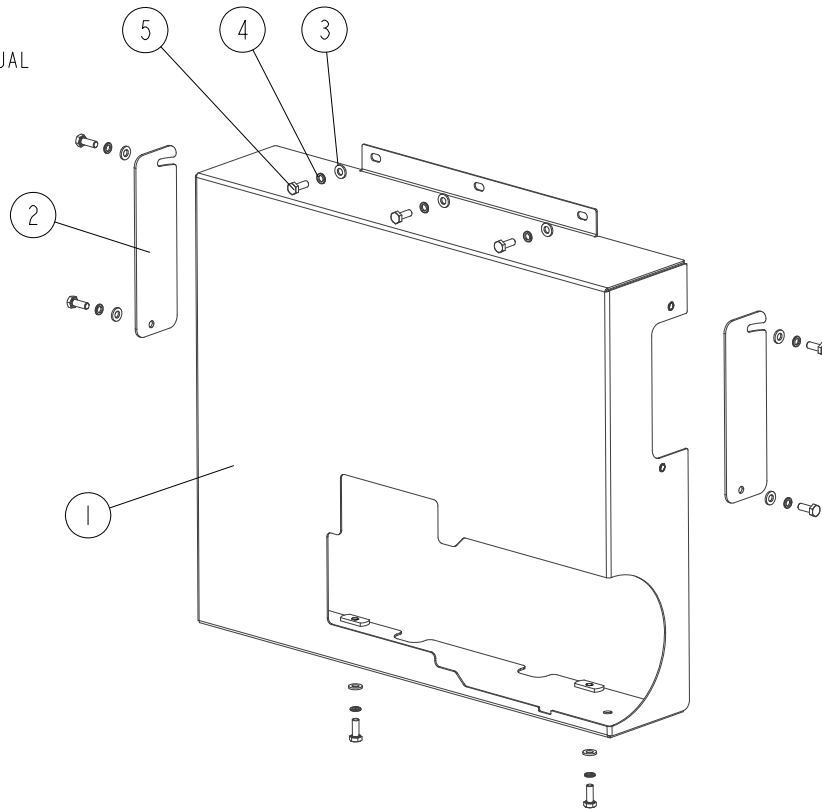

## 4.7 Table Drive Cover Assembly (EG100 Edgers w/Adjustable Feed)

T00443\_001  
T00443\_MANUAL

REF.	DESCRIPTION (◆ Indicates Parts Available in Assemblies Only)	PART#	QTY	
-	<b>COVER ASSEMBLY, TABLE DRIVE</b>	T00443	1	
1	COVER WELDMENT, TABLE DRIVE	T00445-1	1	
2	PLATE, COVER	T00231-1	2	
3	WASHER, 6.4 FLAT ZINC	F81053-1	9	
4	WASHER, Z 6.1 SPLIT LOCK ZINC	F81053-3	9	
5	BOLT, M6X16-8.8 HEX HEAD FULL THREAD ZINC	F81001-15	9	

4.8 Table Drive Assembly

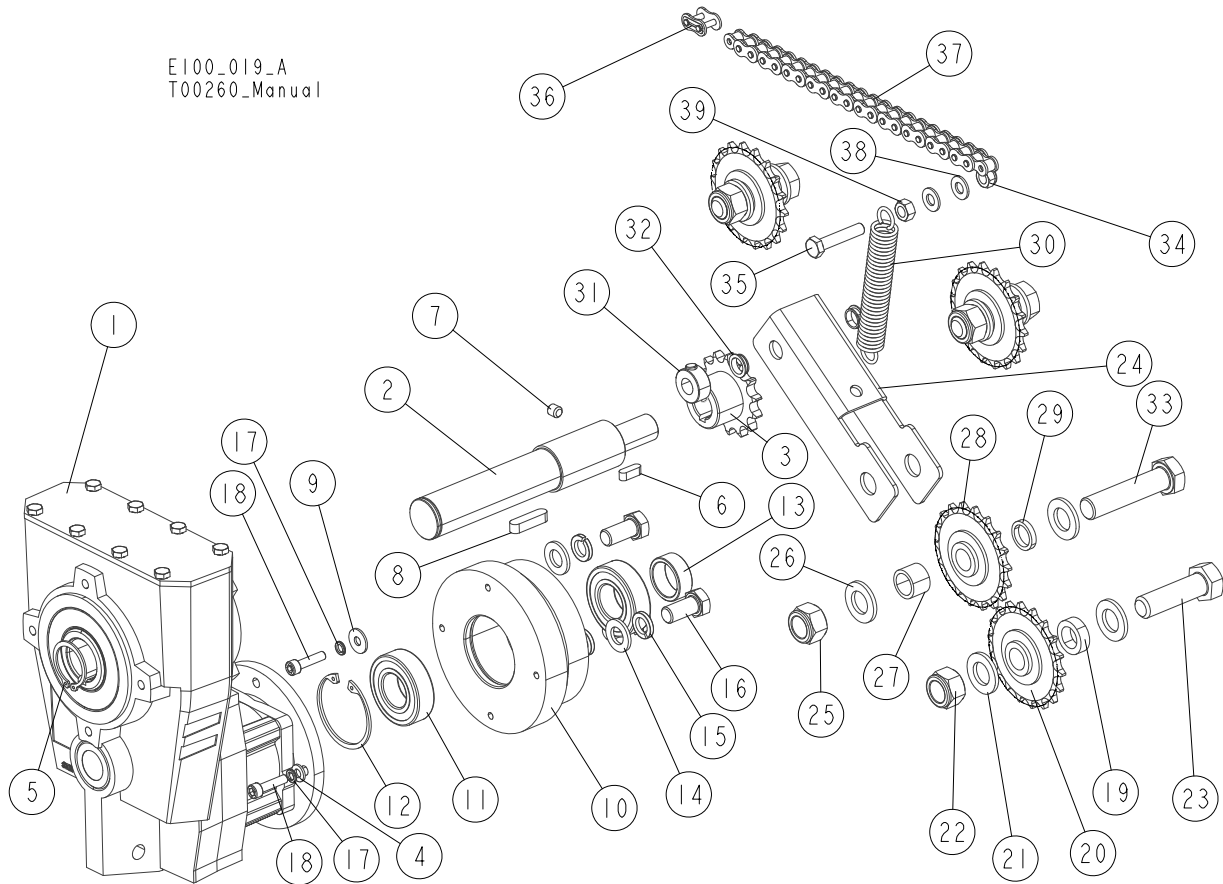

REF.	DESCRIPTION (◆ Indicates Parts Available in Assemblies Only)	PART#	QTY
	<b>DRIVE ASSEMBLY, TABLE</b>	<b>T00256</b>	<b>1</b>
	<b>REDUCER, TABLE DRIVE</b>	T00300	1
1	REDUCER, HR302/64.51[120/19] WBS/B8	T00170	1
2	SHAFT, REDUCER OUTPUT	T00302-1	1
3	SPROCKET, 10B Z14	090702-1	1
4	WASHER, 6.4 FLAT ZINC	F81053-1	3
5	RING, 30Z OUTSIDE RETAINING	F81090-23	1
6	KEY, A 6X6X18	089404	1
7	SCREW, M8X8-33H GEOMET HEX SOCKET SET W/FLAT POINT	F81014-1	1
8	KEY, A8X7X32 PARALLEL	088564	1
9	WASHER, 6.5 SPECIAL FLAT ZINC	F81053-11	1
	<b>HOUSING, MAIN SHAFT BEARING - COMPLETE</b>	T00435	1
10	HOUSING, MAIN SHAFT BEARING	T00379-1	1
11	BEARING, 6205-2RSH SKF	087353	2
12	RING, W52 INSIDE RETAINING	F81090-6	1
13	BUSHING, 25.5/32-12 ZINC-PLATED	097942-1	1
14	WASHER, 13 FLAT ZINC	F81056-1	3
15	WASHER, Z12.2 SPLIT LOCK ZINC	F81056-2	3
16	BOLT, M12X25-8.8 HEX HEAD FULL THREAD ZINC	F81004-31	3
17	WASHER, Z 6.1 SPLIT LOCK ZINC	F81053-3	4
18	SCREW, M6X25-8.8 HEX SOCKET HEAD CAP ZINC	F81001-41	4
	<b>SPROCKET, CHAIN GUIDE - COMPLETE</b>	T00254	3

REF.	DESCRIPTION (◆ Indicates Parts Available in Assemblies Only)	PART#	QTY
19	BUSHING, 16.1/25-8 ZINC-PLATED	T00255-1	1
20	SPROCKET, Z=18 LARGE	088700	1
21	WASHER, 17 SPLIT LOCK ZINC	F81058-1	2
22	NUT, M16-8 HEX NYLON ZINC LOCK	F81036-2	1
23	BOLT, M16X55-8.8 HEX HEAD FULL THREAD ZINC	F81006-61	1
	<b>TENSIONER, CHAIN - COMPLETE</b>	T00215	1
24	LEVER, CHAIN TENSIONER	T00216-1	1
25	NUT, M16-8 HEX NYLON ZINC LOCK	F81036-2	1
26	WASHER, 17 SPLIT LOCK ZINC	F81058-1	2
27	BUSHING, 16 1/21 3-15	T00217-1	1
28	SPROCKET, Z=18 LARGE	088700	1
29	BUSHING, 16 1/21 3-4	T00218-1	1
30	SPRING, 3/4x 5x.095	015569	1
31	RING, 12 STOPPING LIGHT TYPE	F81039-16	1
32	BUSHING, IGUS MCM-12-03	T00165	2
33	BOLT, M16x70 HEX HEAD ZINC	F81006-16	1
34	NUT, M8 8 HEX NYLON ZINC LOCK	F81032-2	1
35	BOLT, M8X40-8.8 HEX HEAD FULL THREAD ZINC	F81002-15	1
36	LINK, 08B-1PZ MASTER	091625	1
37	CHAIN, 08B-1 L=13081 mm 103-LINK	T00257	1
38	WASHER, 8.4 FLAT ZINC	F81054-1	2
39	NUT, M8-8-B HEX ZINC	F81032-1	1

4.9 Table Drive Assembly (EG100 Edgers w/Adjustable Feed)

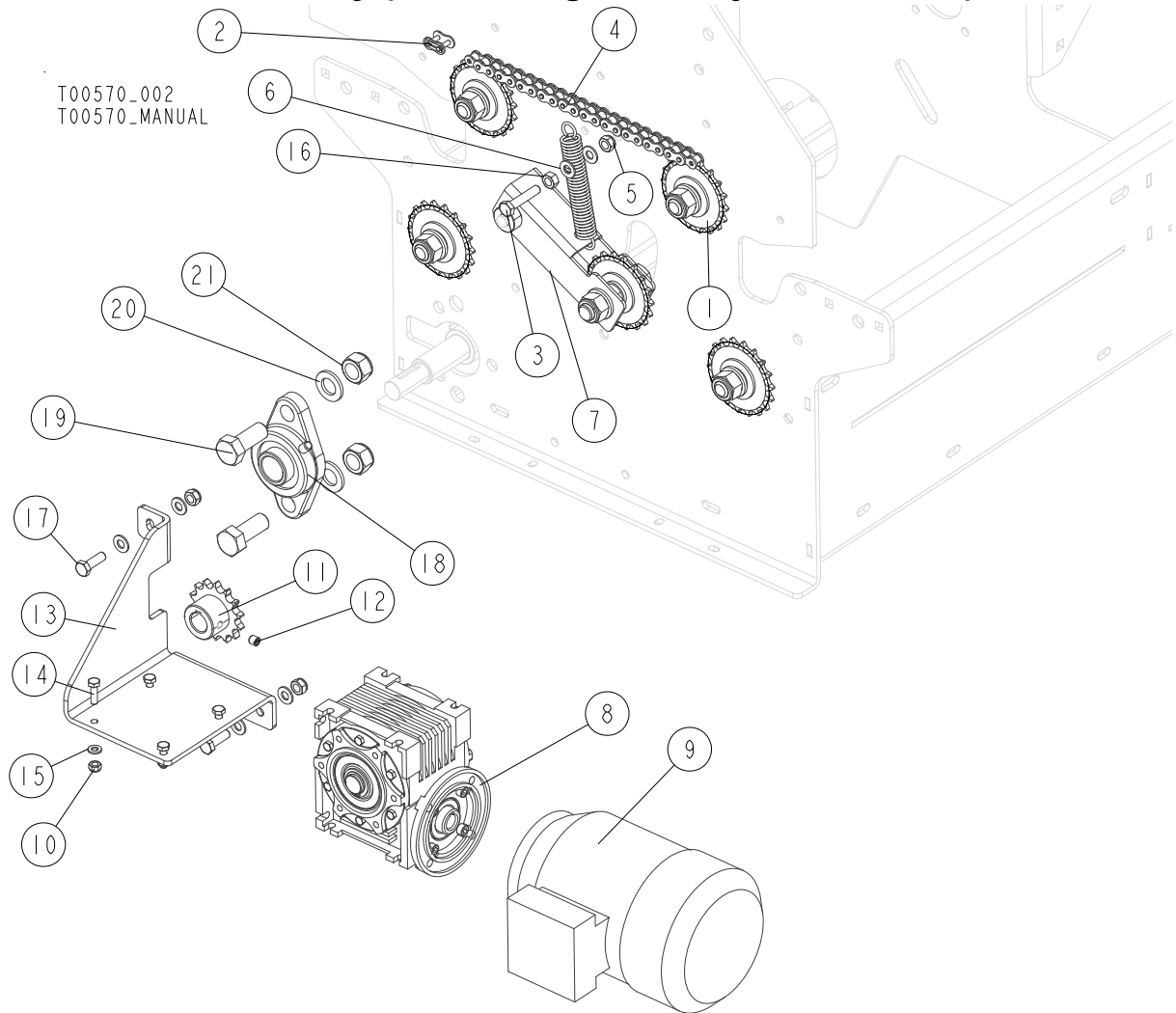

REF.	DESCRIPTION (◆ Indicates Parts Available in Assemblies Only)	PART#	QTY
-	<b>DRIVE ASSEMBLY, TABLE</b>	<b>T00441</b>	<b>1</b>
1	SPROCKET, CHAIN GUIDE - COMPLETE <a href="#">See Section 4.10</a>	T00254	4
2	LINK, 08B-1PZ MASTER	091625	1
3	BOLT, M8X40-8.8 HEX HEAD FULL THREAD ZINC	F81002-15	1
4	CHAIN, 08B-1 L=1485.9 mm 117-LINK	T00439	1
5	NUT, M8 8 HEX NYLON ZINC LOCK	F81032-2	4
6	WASHER, 8.4 FLAT ZINC	F81054-1	8
7	TENSIONER, CHAIN - COMPLETE <a href="#">See Section 4.11</a>	T00215	1
-	<b>MOTOREDUCER, MR-40/21[0.37-1400-105/14]WJ1/B3</b>	<b>524200</b>	<b>1</b>
8	REDUCER, MR-40/21[105/14]WJ1/B3	524201	1
9	MOTOR, SKH71-4B2	091304	1
10	NUT, M6-8-B HEX NYLON ZINC LOCK	F81031-2	4
11	SPROCKET, 08B Z14 ZINC-PLATED	090702-1	1
12	SCREW, M8X8-33H GEOMET HEX SOCKET SET W/FLAT POINT	F81014-1	1
13	BRACKET, MOTOREDUCER	T00442-1	1
14	BOLT, M6X20 8.8 HEX HEAD FULL THREAD ZINC	F81001-2	4
15	WASHER, 6.4 FLAT ZINC	F81053-1	4
16	NUT, M8-8-B HEX ZINC	F81032-1	1

## Table Drive Assembly (EG100 Edgers w/Adjustable Feed)

REF.	DESCRIPTION (◆ Indicates Parts Available in Assemblies Only)	PART#	QTY	
17	BOLT, M8X25-8.8-B HEX HEAD FULL THREAD ZINC	F81002-5	3	
18	BEARING, UCFL205 W/HOUSING (COMPLEX)	089124	1	
19	BOLT, M16X40-8.8 HEX HEAD FULL THREAD ZINC	F81006-13	2	
20	WASHER, 17 SPLIT LOCK ZINC	F81058-1	2	
21	NUT, M16-8 HEX NYLON ZINC LOCK	F81036-2	2	

# 4

## Main Module

### Chain Guide Sprocket

#### 4.10 Chain Guide Sprocket

T00254\_001  
T00254\_MANUAL

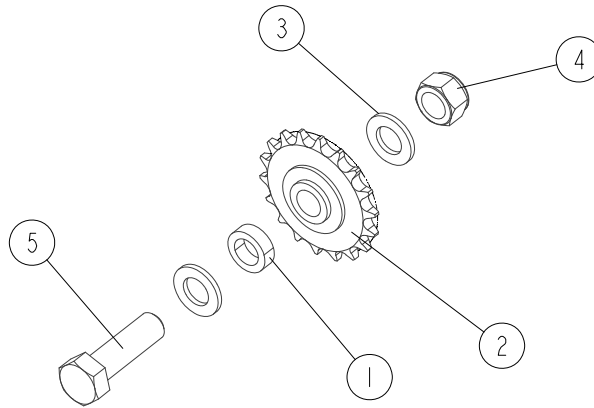

REF.	DESCRIPTION (◆ Indicates Parts Available in Assemblies Only)	PART#	QTY
-	<b>SPROCKET, CHAIN GUIDE - COMPLETE</b>	<b>T00254</b>	<b>1</b>
1	BUSHING, 16.1/25-8	T00255-1	1
2	SPROCKET, Z=18 LARGE	088700	1
3	WASHER, 17 SPLIT LOCK ZINC	F81058-1	2
4	NUT, M16-8 HEX NYLON ZINC LOCK	F81036-2	1
5	BOLT, M16X55-8.8 HEX HEAD FULL THREAD ZINC	F81006-61	1

## 4.11 Chain Tensioner

T00215\_001  
T00215\_MANUAL

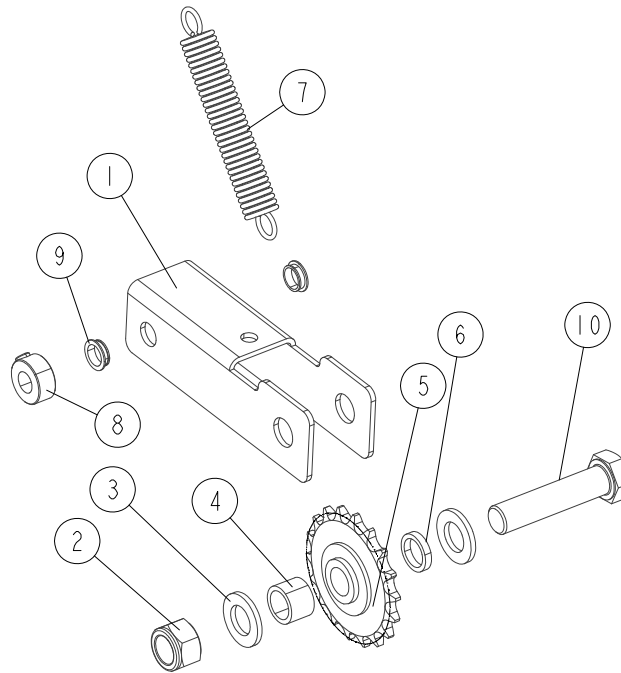

REF.	DESCRIPTION (◆ Indicates Parts Available in Assemblies Only)	PART#	QTY
-	TENSIONER, CHAIN - COMPLETE	T00215	1
1	LEVER, CHAIN TENSIONER	T00216-1	1
2	NUT, M16-8 HEX NYLON ZINC LOCK	F81036-2	1
3	WASHER, 17 SPLIT LOCK ZINC	F81058-1	2
4	BUSHING, 16.1/21.3-15	T00217-1	1
5	SPROCKET, Z=18 LARGE	088700	1
6	BUSHING, 16.1/21.3-4	T00218-1	1
7	SPRING, 3/4x 5x.095	015569	1
8	RING, 12 STOPPING LIGHT TYPE	F81039-16	1
9	BUSHING, IGUS MCM-12-03	T00165	2
10	BOLT, M16X70 HEX HEAD ZINC	F81006-16	1

4.12 Upper Blade Cover

E100\_020  
T00260\_Manual

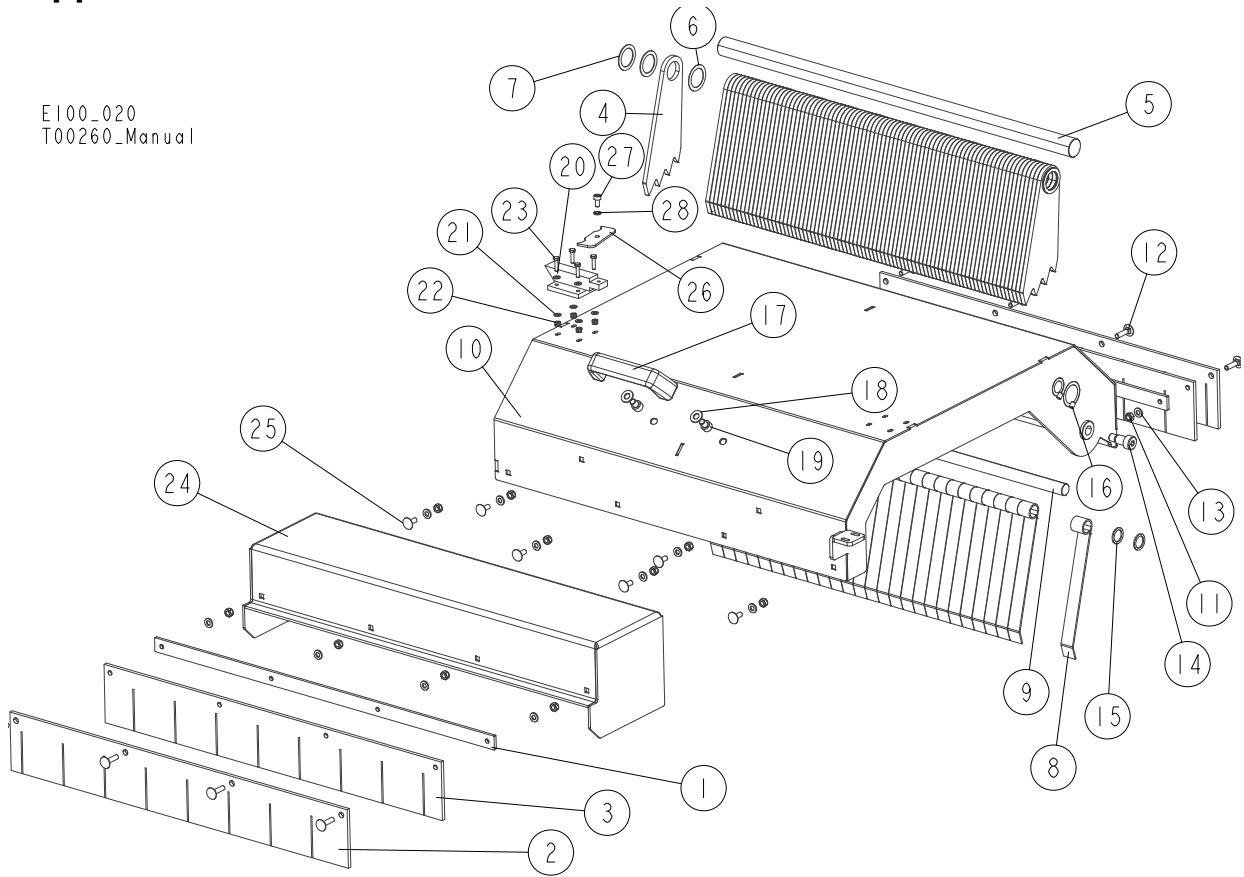

REF.	DESCRIPTION (◆ Indicates Parts Available in Assemblies Only)	PART#	QTY
	<b>COVER, UPPER - COMPLETE</b>	T00281	1
1	BAR, CLAMPING FLAT	T00184-1	2
2	GUARD, FLEXIBLE (I)	T00279	2
3	GUARD, FLEXIBLE (II)	T00280	2
	<b>ANTI-KICKBACK ASSEMBLY</b>	T00147	1
4	FINGER, ANTI-KICKBACK ZINC-PLATED	T00146-1	82
5	SHAFT, ANTI-KICKBACK FINGER ZINC	T00145-1	1
6	WASHER, DIN988 36x26x0.5 SPACER STAINLESS STEEL	T00323	83
7	WASHER, 25.5/35-1.5	503406	4
	<b>SHIELD ASSEMBLY, SPLINTER</b>	T00148	1
8	PLATE, SPLINTER SHIELD ZINC-PLATED	T00149-1	27
9	SHAFT, SPLINTER SHIELD ZINC-PLATED	T00278-1	1
10	COVER WELDMENT	T00270-1	1
11	NUT, M6-8-B HEX NYLON ZINC LOCK	F81031-2	14
12	BOLT, M6X25-8.8 CARRIAGE ZINC	F81001-20	8
13	WASHER, 6.4 FLAT ZINC	F81053-1	14
14	BOLT, 12/M10X16 12.9 ISO7379/BN1359 BOSSARD SOCKET HEAD	F81003-64	2
15	WASHER, 16.5/22-1.5	T00185	4
16	SCREW, M6x8-33H-GEOMET HEX SOCKET SET	F81013-1	4
17	HANDLE, UPPER COVER	T00236	1
18	WASHER, 8.4 FLAT ZINC	F81054-1	2
19	SCREW, M8X10-8.8 HEX SOCKET HEAD CAP ZINC	F81002-32	2
20	LATCH, K-4 GP	T00198	1



REF.	DESCRIPTION (◆ Indicates Parts Available in Assemblies Only)	PART#	QTY	
21	WASHER, 4.3 FLAT ZINC	F81051-2	8	
22	NUT, M4-8 HEX NYLON ZINC LOCK	F81029-1	4	
23	BOLT, M4X16-8.8 HEX HEAD FULL THREAD ZINC	F81011-6	4	
24	COVER, ADDITIONAL	T00227-1	1	
25	BOLT, M6X16-8.8 CARRIAGE ZINC	F81001-36	6	
26	BRACKET, COVER ZINC-PL. LOCK	T00365-1	1	
27	SCREW, M4X8 8.8 HEX SOCKET HEAD CAP ZINC	F81011-36	1	
28	WASHER, Z 4.1 SPLIT LOCK ZINC	F81051-1	1	

## 4.13 Upper Blade Cover (Non CE Version)

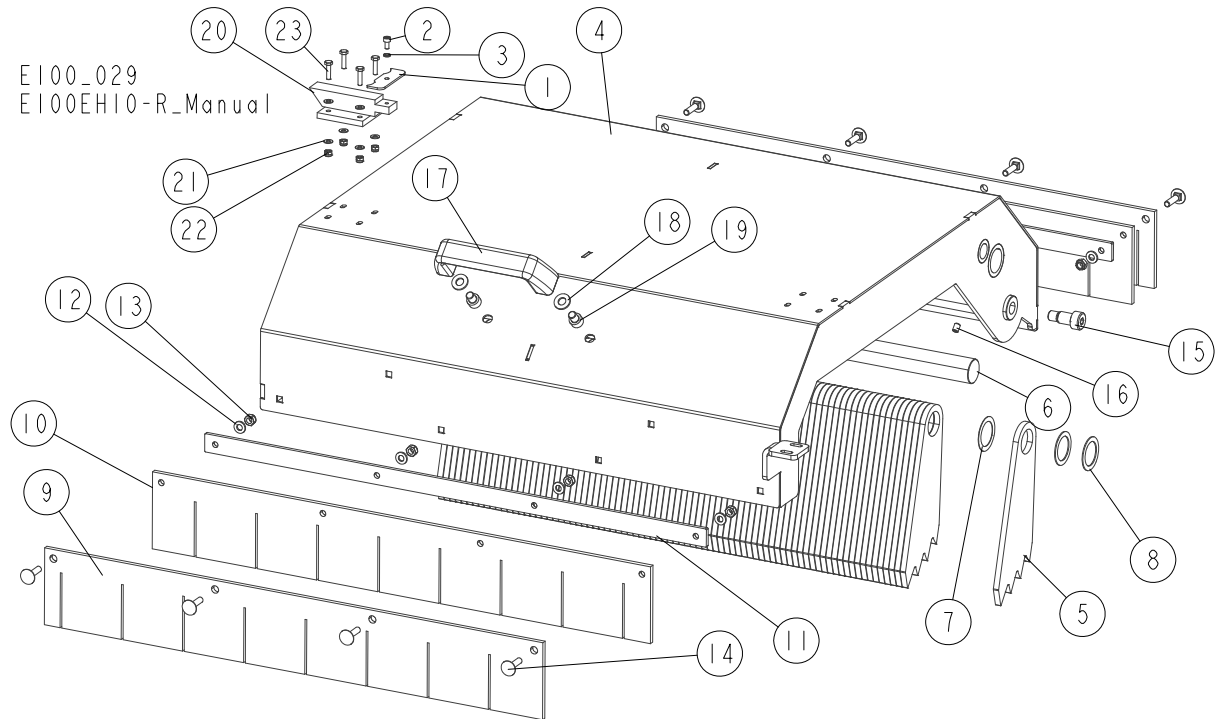

REF.	DESCRIPTION (◆ Indicates Parts Available in Assemblies Only)	PART#	QTY
	<b>COVER, UPPER - COMPLETE</b>	<b>T00281-3</b>	<b>1</b>
1	BRACKET, COVER ZINC-PL. LOCK	T00365-1	1
2	SCREW, M4X8 8.8 HEX SOCKET HEAD CAP ZINC	F81011-36	1
3	WASHER, Z 4.1 SPLIT LOCK ZINC	F81051-1	1
4	COVER WELDMENT	T00270-1	1
	<b>ANTI-KICKBACK ASSEMBLY</b>	<b>T00147</b>	<b>1</b>
5	FINGER, ANTI-KICKBACK ZINC-PLATED	T00146-1	83
6	SHAFT, ANTI-KICKBACK FINGER ZINC-PLATED	T00145-1	1
7	WASHER, DIN988 36x26x0.5 SPACER STAINLESS STEEL	T00323	82
8	WASHER, 25.5/35-1.5	503406	4
9	GUARD, FLEXIBLE (I)	T00279	2
10	GUARD, FLEXIBLE (II)	T00280	2
11	BAR, CLAMPING FLAT	T00184-1	2
12	WASHER, 6.4 FLAT ZINC	F81053-1	8
13	NUT, M6-8-B HEX NYLON ZINC LOCK	F81031-2	8
14	BOLT, M6X25-8.8 CARRIAGE ZINC	F81001-20	8
15	BOLT, 12/M10X16 12.9 ISO7379/BN1359 BOSSARD SOCKET HEAD	F81003-64	2
16	SCREW, M6X8-33H-GEOMET HEX SOCKET SET W/CONE POINT	F81013-1	2
17	HANDLE, UPPER COVER	T00236	1
18	WASHER, 8.4 FLAT ZINC	F81054-1	2
19	SCREW, M8X10-8.8 HEX SOCKET HEAD CAP ZINC	F81002-32	2
20	LATCH, K-4 GP	T00198	1
21	WASHER, 4.3 FLAT ZINC	F81051-2	8
22	NUT, M4-8 HEX NYLON ZINC LOCK	F81029-1	4
23	BOLT, M4X16-8.8 HEX HEAD FULL THREAD ZINC	F81011-6	4

## 4.14 Main Shaft &amp; Fixed Blade (EG100 Edgers w/Adjustable Feed)

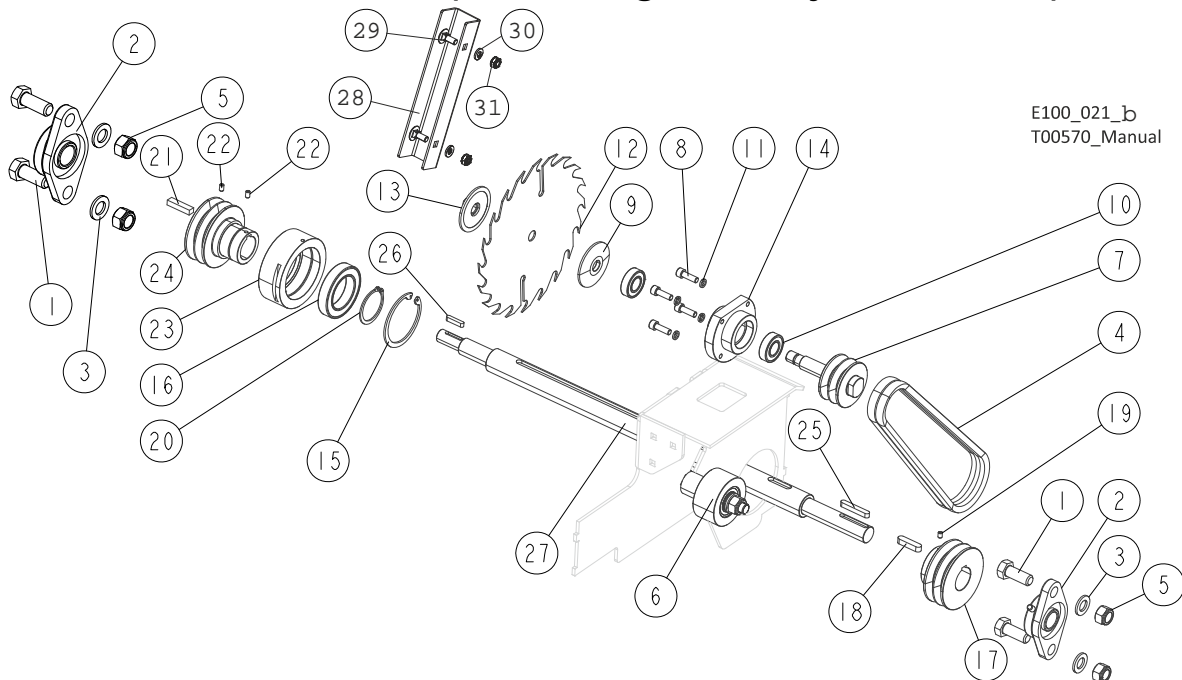

REF.	DESCRIPTION (◆ Indicates Parts Available in Assemblies Only)	PART#	QTY
1	BOLT, M16x40-8.8 HEX HEAD FULL THREAD ZINC	F81006-13	4
2	BEARING, UCFL205 W/HOUSING (COMPLEX)	089124	2
3	WASHER, 17 SPLIT LOCK ZINC	F81058-1	4
4	BELT, CONTINENTAL AVX 13 x 830 La	T00269	2
5	NUT, M16-8 HEX NYLON ZINC LOCK	F81036-2	4
6	TENSIONER, BLADE DRIVE BELT <a href="#">See Section 4.4</a>	T00522	1
-	<b>BLADE ASSEMBLY, FIXED</b>	<b>T00545</b>	<b>1</b>
7	SHAFT, FIXED BLADE	T00514-1	1
8	SCREW, M8X25 8.8 HEX SOCKET HEAD CAP ZINC	F81002-21	4
9	DISC, BLADE MOUNTING	T00263-1	1
10	BEARING, 6004 2RS CX ROLLING	093868	2
11	WASHER, 8.2 SPLIT LOCK ZINC	F81054-4	4
12	BLADE, CIRCULAR	T00168	1
13	NUT, FIXED BLADE	T00266-1	1
14	SLEEVE, FIXED BLADE BEARING	T00547-1	1
-	<b>SHAFT, MAIN - COMPLETE</b>	<b>T00542</b>	<b>1</b>
15	RING, W80 INSIDE RETAINING	F81090-25	1
16	BEARING, 6010 2RS	506549	1
17	PULLEY, 2X13X95	T00519-1	1
18	KEY, A10X8X40 PARALLEL	502045	1
19	SCREW, M6X8-33H-GEOMET HEX SOCKET SET W/CONE POINT	F81013-1	1
20	RING, Z50 OUTSIDE RETAINING	F81090-28	1
21	KEY, B10X8X40	T00306	1
22	SCREW, M6X10-45H HEX SOCKET ZINC SET W/FLAT POINT	F81001-26	2
23	HOUSING, BEARING	T00305-1	1
24	BUSHING, SLIDE	T00541-1	1
25	KEY, A8X7X50 PARALLEL	088563	1
26	KEY, A6X6X30	094245	1
27	SHAFT, MAIN	T00303-1	1

**4****Main Module***Main Shaft & Fixed Blade (EG100 Edgers w/Adjustable Feed)*

---

REF.	DESCRIPTION (◆ Indicates Parts Available in Assemblies Only)	PART#	QTY	
28	GUIDE, SAWDUST	T00662-1	1	
29	BOLT, M6x16-8.8 CARRIAGE ZINC	F81001-36	2	
30	WASHER, M6, FLAT,ZINC	F81053-1	2	
31	NUT,M6-8-B HEX,NYLON LOCK ZINC	F81031-2	2	

## 4.15 Fixed Blade & Main Shaft

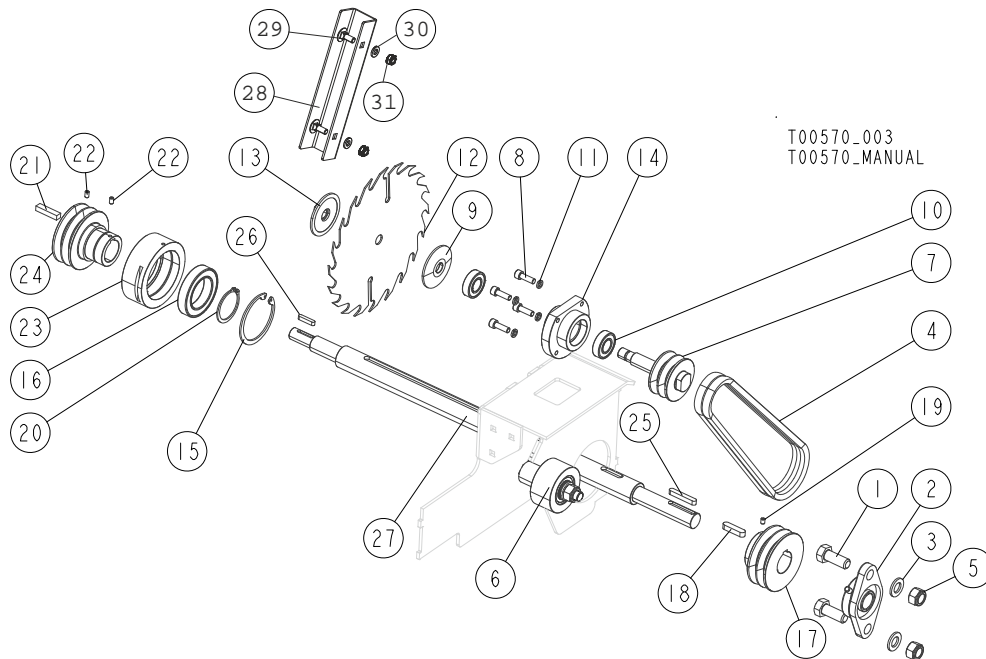

REF.	DESCRIPTION (◆ Indicates Parts Available in Assemblies Only)	PART#	QTY
1	BOLT, M16x40-8.8 HEX HEAD FULL THREAD ZINC	F81006-13	2
2	BEARING, UCFL205 W/HOUSING (COMPLEX)	089124	1
3	WASHER, 17 SPLIT LOCK ZINC	F81058-1	2
4	BELT, CONTINENTAL AVX 13 x 830 La	T00269	2
5	NUT, M16-8 HEX NYLON ZINC LOCK	F81036-2	2
6	TENSIONER, BLADE DRIVE BELT <a href="#">See Section 4.4</a>	T00522	1
-	<b>BLADE ASSEMBLY, FIXED</b>	<b>T00545</b>	<b>1</b>
7	SHAFT, FIXED BLADE	T00514-1	1
8	SCREW, M8X25 8.8 HEX SOCKET HEAD CAP ZINC	F81002-21	4
9	DISC, BLADE MOUNTING	T00263-1	1
10	BEARING, 6004 2RS CX ROLLING	093868	2
11	WASHER, 8.2 SPLIT LOCK ZINC	F81054-4	4
12	BLADE, CIRCULAR	T00168	1
13	NUT, FIXED BLADE	T00266-1	1
14	SLEEVE, FIXED BLADE BEARING	T00547-1	1
-	<b>SHAFT, MAIN - COMPLETE</b>	<b>T00542</b>	<b>1</b>
15	RING, W80 INSIDE RETAINING	F81090-25	1
16	BEARING, 6010 2RS	506549	1
17	PULLEY, 2X13X95	T00519-1	1
18	KEY, A10X8X40 PARALLEL	502045	1
19	SCREW, M6X8-33H-GEOMET HEX SOCKET SET W/CONE POINT	F81013-1	1
20	RING, Z50 OUTSIDE RETAINING	F81090-28	1
21	KEY, B10X8X40	T00306	1
22	SCREW, M6X10-45H HEX SOCKET ZINC SET W/FLAT POINT	F81001-26	2
23	HOUSING, BEARING	T00305-1	1
24	BUSHING, SLIDE	T00541-1	1
25	KEY, A8X7X50 PARALLEL	088563	1
26	KEY, A6X6X30	094245	1
27	SHAFT, MAIN	T00303-1	1

**4****Main Module***Fixed Blade & Main Shaft*

---

REF.	DESCRIPTION (◆ Indicates Parts Available in Assemblies Only)	PART#	QTY	
28	GUIDE, SAWDUST	T00662-1	1	
29	BOLT, M6x16-8.8 CARRIAGE ZINC	F81001-36	2	
30	WASHER, M6, FLAT,ZINC	F81053-1	2	
31	NUT,M6-8-B HEX,NYLON LOCK ZINC	F81031-2	2	

### 4.16 Main Module Base

T00188\_001  
T00188\_MANUAL

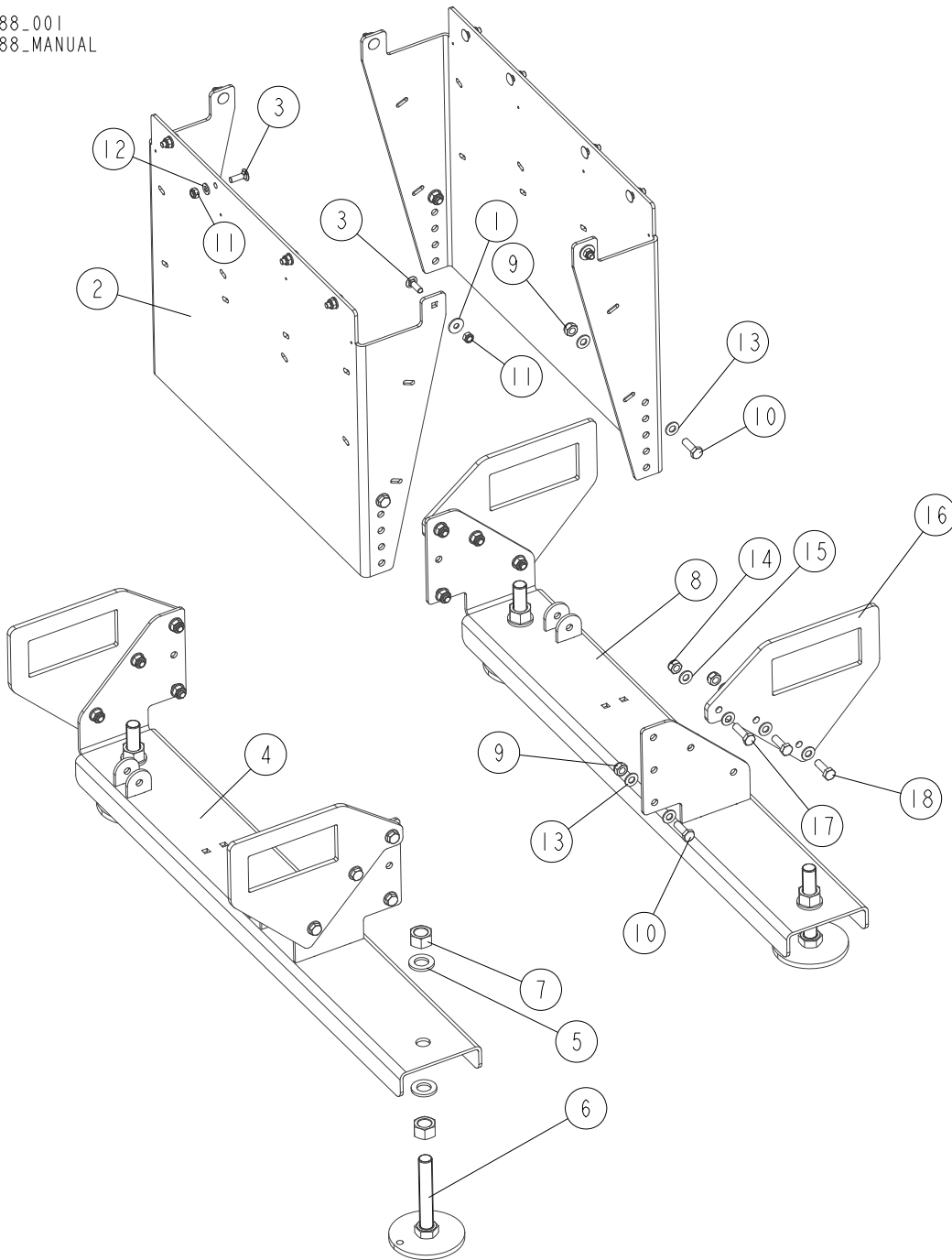

REF.	DESCRIPTION (◆ Indicates Parts Available in Assemblies Only)	PART#	QTY
-	<b>BASE, MAIN MODULE</b>	T00188	1
1	WASHER, ISO 7093-1-8-200 HV-A2E	F81054-11	4
2	PLATE, BASE SIDE	T00197-1	2
3	BOLT, M8x25-8.8 CARRIAGE ZINC	F81002-59	12
4	BRACKET, FOOT LEFT	T00189-1	1
-	<b>FOOT, COMPLETE</b>	<b>T00194</b>	<b>4</b>
5	WASHER, 21 FLAT ZINC	F81059-2	2
6	FOOT WELDMENT	T00195-1	1
7	NUT, M20-8 HEX ZINC	F81037-1	2
8	BRACKET, FOOT RIGHT	T00190-1	1

## 4

**Main Module***Main Module Base*

REF.	DESCRIPTION (◆ Indicates Parts Available in Assemblies Only)	PART#	QTY	
9	NUT, M10-8-B HEX NYLON ZINC LOCK	F81033-1	8	
10	BOLT, M10X30 5.8 HEX HEAD FULL THREAD ZINC	F81003-2	8	
11	NUT, M8 8 HEX NYLON ZINC LOCK	F81032-2	12	
12	WASHER, 8.4 FLAT ZINC	F81054-1	8	
13	WASHER, 10.5 FLAT ZINC	F81055-1	16	
-	TRANSPORT BRACKET KIT	T00643 <sup>1</sup>	1	
14	NUT,M10-8-B NYLON HEX ZINC LOCK	F81033-1	12	
15	WASHER, 10.5 FLAT ZINC	F81055-1	24	
16	BRACKET, TRANSPORT	T00642-1	4	
17	BOLT,M10X35-8.8 HEX HEAD FULL THREAD ZIN	F81003-17	4	
18	BOLT,M10X30-5.8 HEX HEAD FULL THREAD	F81003-2	8	

<sup>1</sup> Option



### 4.17 Sawdust Hopper

E100\_023  
T00260\_Manual

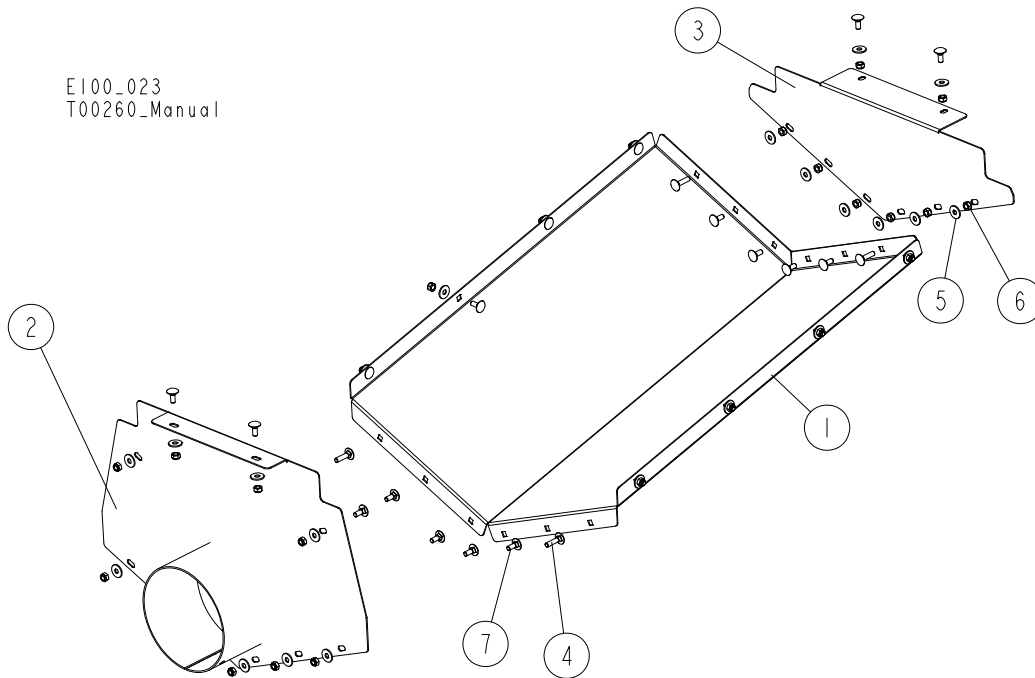

REF.	DESCRIPTION (◆ Indicates Parts Available in Assemblies Only)	PART#	QTY
	<b>HOPPER, SAWDUST - COMPLETE</b>	<b>T00121</b>	<b>1</b>
1	PLATE, BOTTOM	T00122-1	1
2	PLATE, FRONT	T00123-1	1
3	PLATE, REAR	T00126-1	1
4	BOLT, M6x25-8.8 CARRIAGE ZINC	F81001-20	4
5	WASHER, 6.5 SPECIAL FLAT ZINC	F81053-11	26
6	NUT, M6-8-B HEX NYLON ZINC LOCK	F81031-2	26
7	BOLT, M6X16-8.8 CARRIAGE ZINC	F81001-36	22

# 4 Main Module

Main Module

## 4.18 Main Module

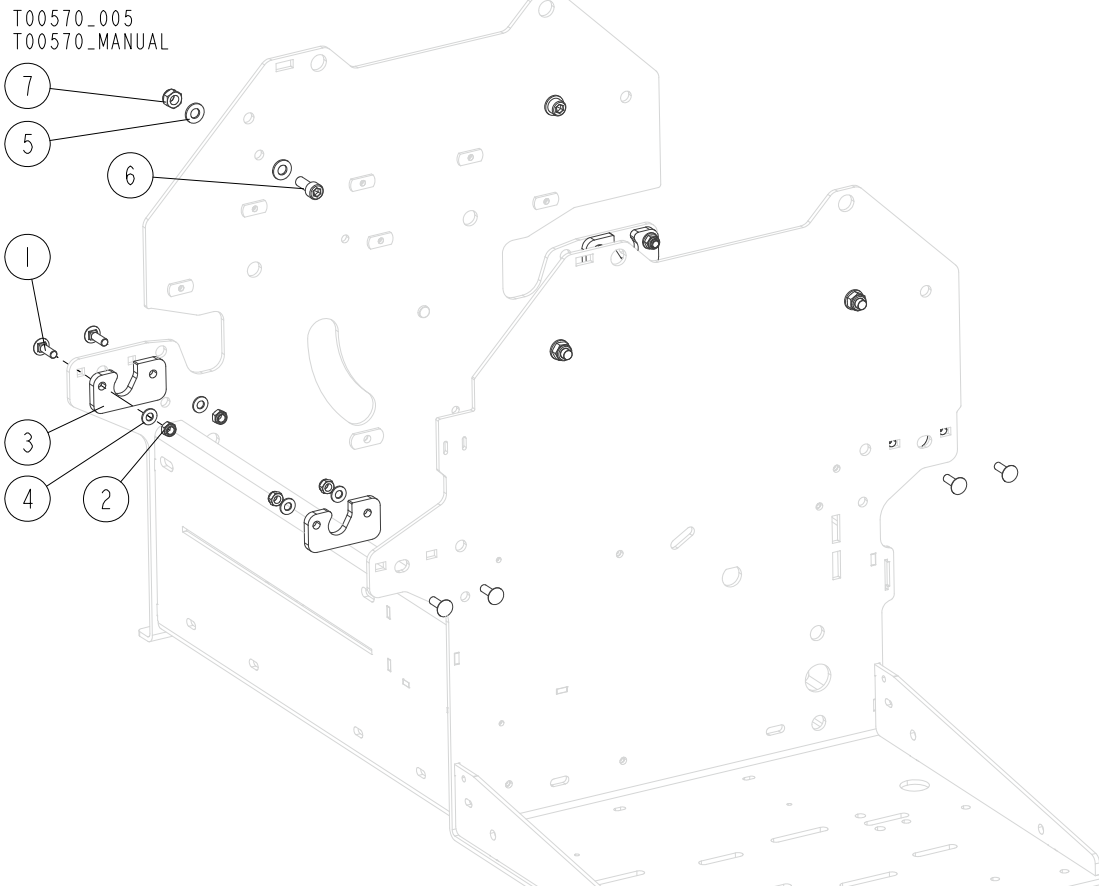

REF.	DESCRIPTION (◆ Indicates Parts Available in Assemblies Only)	PART#	QTY	
1	BOLT, M8x25-8.8 CARRIAGE ZINC	F81002-59	8	
2	NUT, M8 8 HEX NYLON ZINC LOCK	F81032-2	8	
3	PLATE, TABLE MOUNT	T00502-1	4	
4	WASHER, 8.4 FLAT ZINC	F81054-1	8	
5	WASHER, 10.5 FLAT ZINC	F81055-1	8	
6	SCREW, M10X25 8.8 HEX SOCKET HEAD CAP ZINC	F81003-32	4	
7	NUT, M10-8-B HEX NYLON ZINC LOCK	F81033-1	4	

## SECTION 5 EG100 Edger Decals

**5** EG100 Edger Decals  
Decals (EG100 Edgers w/Electric Motor)

**5.1** Decals (EG100 Edgers w/Electric Motor)

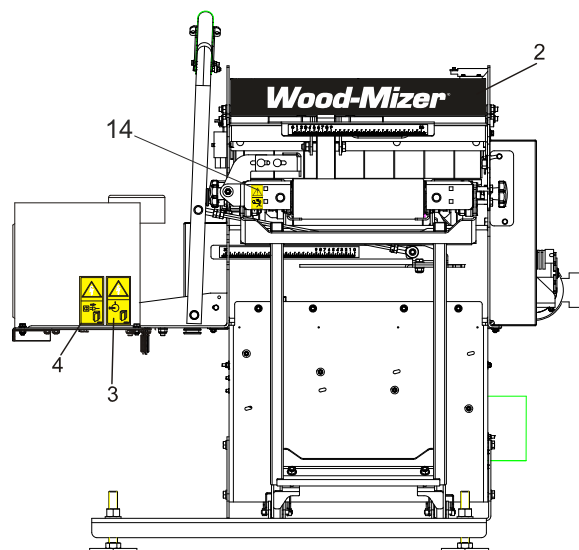
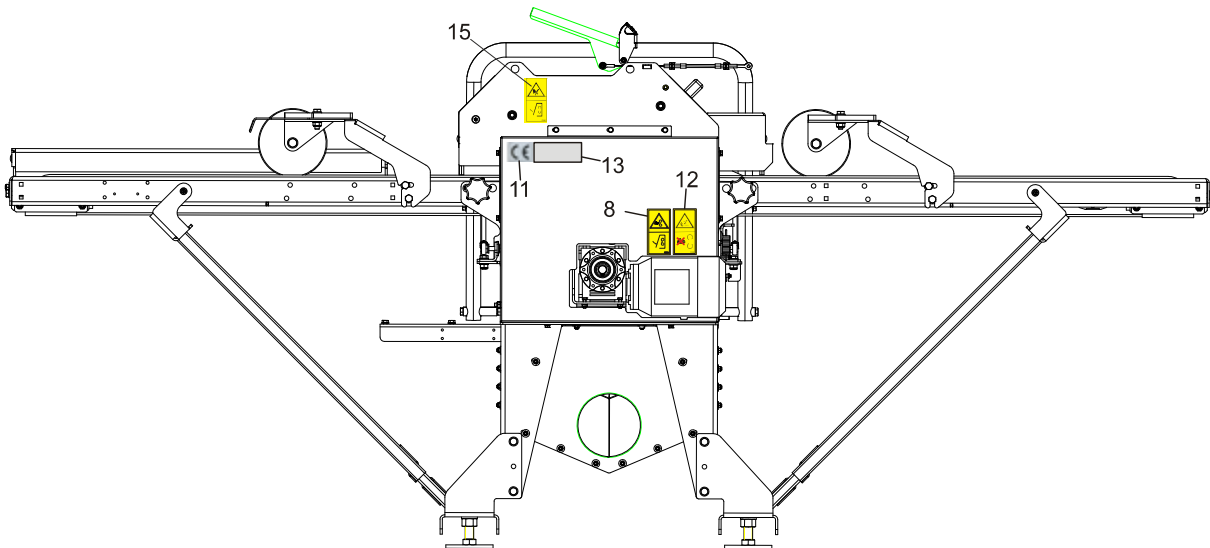
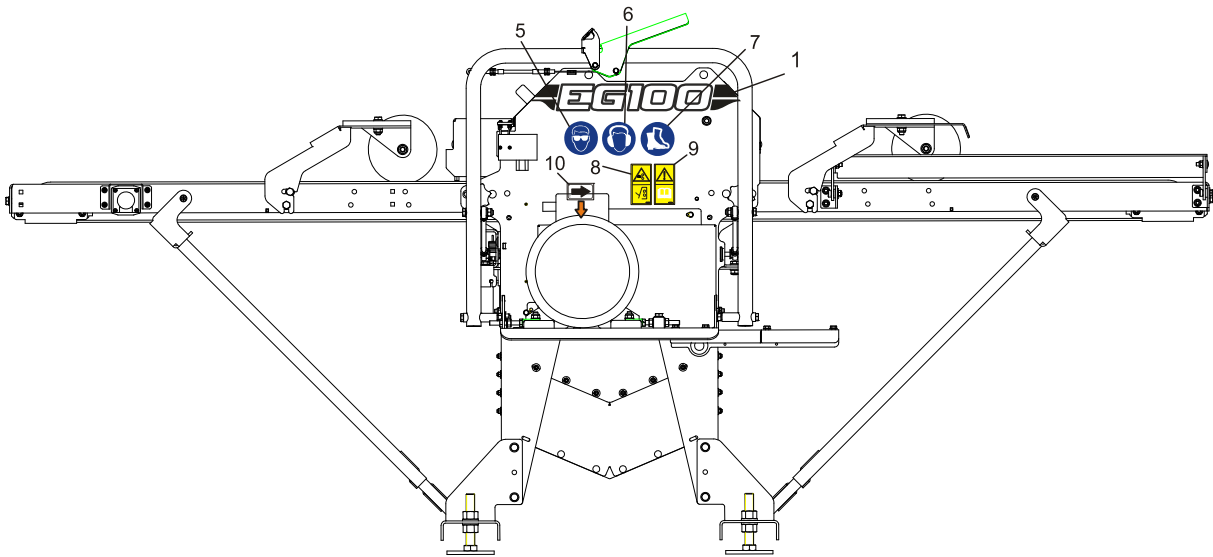

REF.	DESCRIPTION (◆ Indicates Parts Available in Assemblies Only )	PART #	QTY	
	<b>DECAL KIT, EG100 (EDGERS W/ELECTRIC MOTOR)</b>	<b>524994</b>		
<b>1</b>	DECAL, EG100	525987	1	
<b>2</b>	DECAL, WOOD-MIZER	525988	1	
<b>3</b>	DECAL, HIGH VOLTAGE INSIDE THE ELECTRIC BOX (PICTOGRAM)	096316	1	
<b>4</b>	DECAL, REMOVE THE PLUG BEFORE OPENING THE BOX (PICTOGRAM)	096319	1	
<b>5</b>	DECAL, EYE PROTECTION WARNING (PICTOGRAM)	S12004G	1	
<b>6</b>	DECAL, EAR PROTECTION WARNING (PICTOGRAM)	S12005G	1	
<b>7</b>	DECAL, USE SAFETY BOOTS (PICTOGRAM)	501465	1	
<b>8</b>	DECAL, CLOSE COVERS BEFORE OPERATING	099220	2	
<b>9</b>	DECAL, READ THE MANUAL BEFORE OPERATING THE MACHINE (PICTOGRAM)	096317	1	
<b>10</b>	DECAL, MOTOR ROTATION DIRECTION	S20097	1	
<b>11</b>	DECAL, CE CERTIFIED MACHINE (SMALL)	P85070	1	
<b>12</b>	DECAL, GEAR WARNING (PICTOGRAM)	099540	1	
<b>13</b>	DECAL, SERIAL NUMBER	--	1	

# 5 EG100 Edger Decals

Decals (EG100 Edgers w/gas Engine)

## 5.2 Decals (EG100 Edgers w/gas Engine)

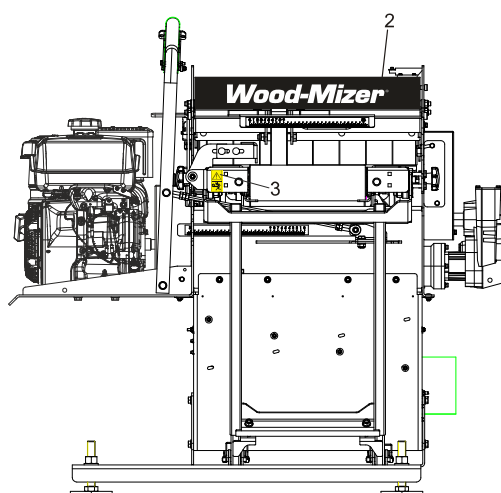
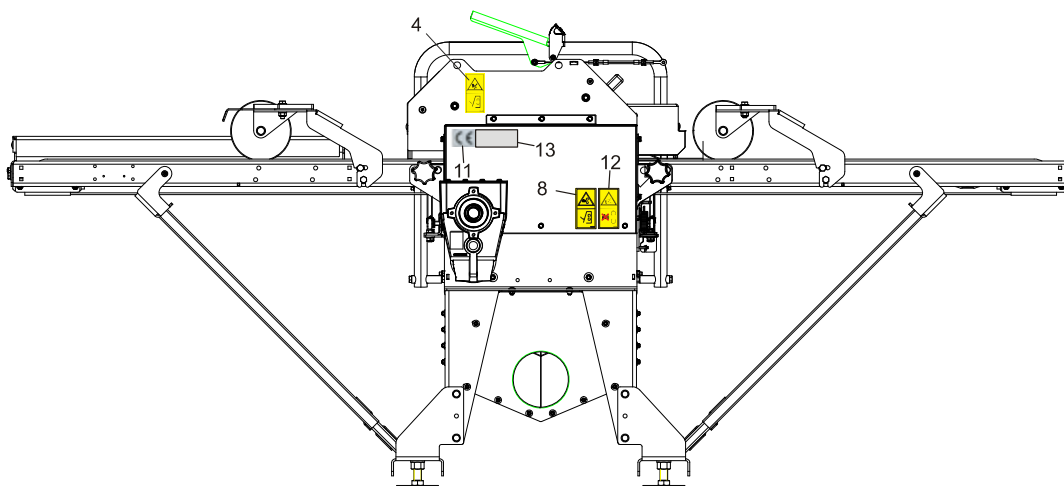
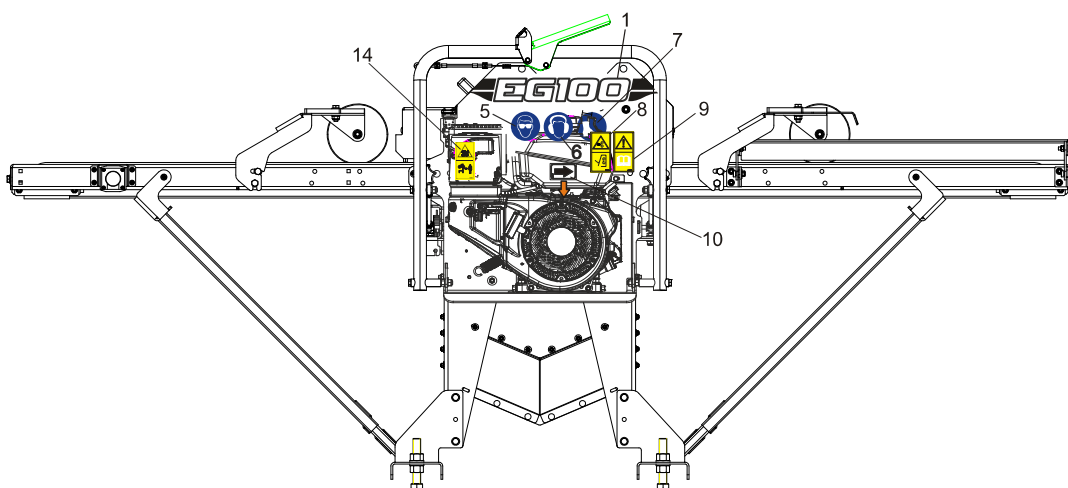

REF.	DESCRIPTION (◆ Indicates Parts Available in Assemblies Only)	PART #	QTY
	DECAL KIT, TIMBERY EG100 (EDGERS W/GAS ENGINE)	529777	
1	DECAL, EG100 LOGO	525987	1
2	DECAL, WOOD-MIZER LOGO	525988	1

REF.	DESCRIPTION (◆ Indicates Parts Available in Assemblies Only)	PART #	QTY	
3	DECAL, HIGH VOLTAGE INSIDE THE ELECTRIC BOX (PICTOGRAM)	096316	1	
4	DECAL, REMOVE THE PLUG BEFORE OPENING THE BOX (PICTOGRAM)	096319	1	
5	DECAL, EYE PROTECTION WARNING (PICTOGRAM)	S12004G	1	
6	DECAL, EAR PROTECTION WARNING (PICTOGRAM)	S12005G	1	
7	DECAL, USE SAFETY BOOTS (PICTOGRAM)	501465	1	
8	DECAL, CLOSE COVERS BEFORE OPERATING	099220	2	
9	DECAL, READ THE MANUAL BEFORE OPERATING THE MACHINE (PICTOGRAM)	096317	1	
10	DECAL, MOTOR ROTATION DIRECTION	S20097	1	
11	DECAL, CE CERTIFIED MACHINE (SMALL)	P85070	1	
12	DECAL, GEAR WARNING (PICTOGRAM)	099540	1	
13	DECAL, SERIAL NUMBER	--	1	