

Wood-Mizer®

Safety, Operation, Maintenance & Parts Manual

**Automatic Setter
AS80 Rev.A.00**



Safety is our #1 concern! Read and understand all safety information and instructions before operating, setting up or maintaining this machine.

June 2009

Form #1033

Table of Contents

Section-Page

SECTION 1	GENERAL INFORMATION AND SAFETY	1-1
1.1	Electrical Safety.....	1-1
1.2	Blade Handling.....	1-2
1.3	Machine Operation	1-2
1.4	Noise Level.....	1-2
1.5	Motor Specifications	1-3
1.6	Technical Data.....	1-3
1.7	Setter Components.....	1-4
1.8	Control Panel Components.....	1-5
1.9	Start Up Modes.....	1-7
1.10	Blade Settings	1-8
1.11	System Parameters.....	1-10
1.12	Diagnostic & Setup.....	1-11
1.13	Power Supply Specification	1-11
SECTION 2	OPERATION	2-1
2.1	Machine Setup	2-1
2.2	Preliminary Setup	2-3
2.3	Machine Operation	2-5
SECTION 3	MAINTENANCE	3-1
3.1	Setter Calibration.....	3-1
3.2	Miscellaneous	3-1
SECTION 4	ALIGNMENT	4-1
4.1	Sensor Adjustment.....	4-1
SECTION 5	TROUBLESHOOTING	5-1
5.1	Error Messages	5-1

Table of Contents

Section-Page

SECTION 6	REPLACEMENT PARTS	6-1
6.1	Pivoting Index Motor Assembly	6-1
6.2	Cam Drive Unit Assembly	6-3
6.3	Front & Back Clamp Assembly	6-5
6.4	Cylinder Clamp Assembly	6-7
6.5	Air Regulator Assembly	6-9
6.6	Rear Adjuster, Blade Height, Index Ramp Assemblies	6-10
6.7	Control Panel	6-12
6.8	Control Base Assembly	6-13
6.9	Blade Support Arms, Index Plate	6-15
6.10	Stand Option	6-16
6.11	Decals, AS80	6-17
SECTION 7	ELECTRICAL INFORMATION	7-1
7.1	AS80 Electrical Diagram.....	7-1
7.2	Electrical Components.....	7-4
7.3	Electrical Component Layout.....	7-4

SECTION 1 GENERAL INFORMATION AND SAFETY



This symbol calls your attention to instructions concerning your personal safety. Be sure to observe and follow these instructions. This symbol accompanies a signal word. The word **DANGER** indicates an imminently hazardous situation which, if not avoided, will result in death or serious injury. **WARNING** suggests a potentially hazardous situation which, if not avoided, could result in death or serious injury. **CAUTION** refers to potentially hazardous situations which, if not avoided, may result in minor or moderate injury to persons or equipment. Read all safety instructions before operating this equipment and observe all safety warnings!



Warning stripes are placed on areas where a single decal would be insufficient. To avoid serious injury, keep out of the path of any equipment marked with warning stripes.

Read and observe all safety instructions before operating this equipment! Also read any additional manufacturer's manuals and observe any applicable safety instructions including dangers, warnings, and cautions.

Always be sure that all safety decals are clean and readable. Replace all damaged safety decals to prevent personal injury or damage to the equipment. Contact your local distributor, or call your Customer Service Representative to order more decals.

Always properly dispose of all by-products, including debris, coolant and oil.

Safety instructions are listed in this section by the following operations:

- Electrical Safety
- Blade Handling
- Machine Operation

1.1 Electrical Safety



DANGER! Make sure all electrical installation, service and/or maintenance work is performed by a qualified electrician and is in accordance with applicable electrical codes.

DANGER! HAZARDOUS VOLTAGE can cause shock, burns, or death. SHUT OFF & LOCK OUT POWER before performing service in any area of this machine. DO NOT restore power until all access panels are replaced and secured.



WARNING! Always turn off and disconnect power at control console AND at main supply circuit breaker before performing any service to the machine.

1.2 Blade Handling



WARNING! Always wear gloves and eye protection when handling bandsaw blades. Keep all persons away from area when coiling or carrying a blade.

1.3 Machine Operation



DANGER! Make sure all guards and covers are in place and secured before operating the toothsetter. Failure to do so may result in serious injury.

DANGER! Keep all persons away from moving parts when operating this machine. Failure to do so will result in serious injury.

DANGER! Always keep hands away from moving bandsaw blade. Failure to do so will result in serious injury.



WARNING! Always wear eye protection when operating this machine. Failure to do so may result in serious injury.

WARNING! Secure all loose clothing and jewelry before operating this machine. Failure to do so may result in serious injury or death.

1.4 Noise Level

See Table 1-1. The level of noise generated by the AS80 Toothsetter is given in the

1 General Information and Safety

Motor Specifications

table below¹.

	Max. Noise Level
IS203	74,8 dB (A)

TABLE 1-1

1.5 Motor Specifications

See Table 1-2. The motor specifications are listed below.

Type	Manufacturer	Model	Power	Other Data
Electric Motor	Klauber	K01134J800	0,04 kW	65 r.p.m.

TABLE 1-2

1.6 Technical Data

See Table 1-3. See the table below for technical data on the AS80 Toothsetter.

Maximum Blade Width	76 mm
Feed Rate	24 teeth / min
Cam Motor Power	0,04 kW
Total Power	0,25kW
Weight	83 kg

TABLE 1-3

See the table below for air supply specification:

Air supply	Pressure
AS80	Min. 4 bar

TABLE 1-3

1. The measured values refer to emission levels, not necessarily to noise levels in the workplace. Although there is a relation between emission levels and exposure levels, it is not possible to determine with certainty if preventives are needed or are not needed. The factors affecting a current level of noise exposure during work are inter alia room characteristics and characteristics of other noise sources, e.g. number of machines and machining operations nearby. Also, the permissible exposure level value may vary depending on country. This information enables the machine's user to better identify hazards and a risk.

1.7 Setter Components

See Figure 1-1. The major component and dimensions of the Automatic Setter are listed below.

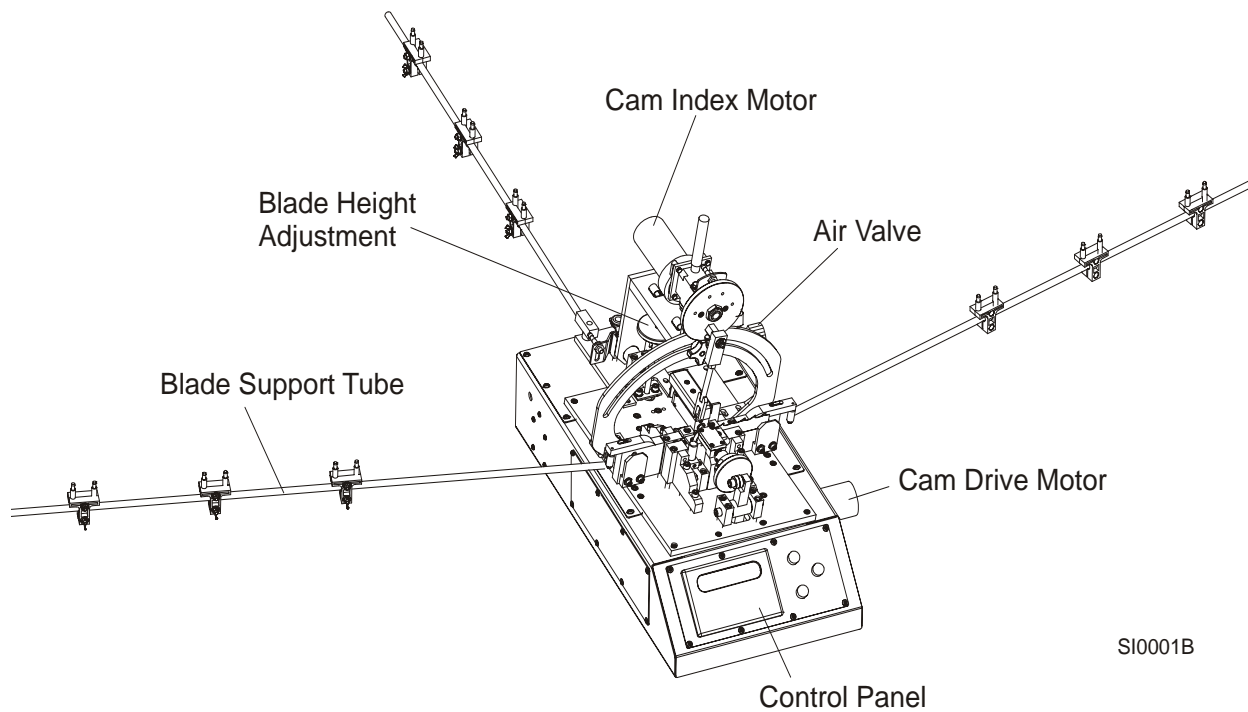

FIG. 1-1

1.8 Control Panel Components

See **Figure 1-2**. The control panel component locations and their functions are listed below.

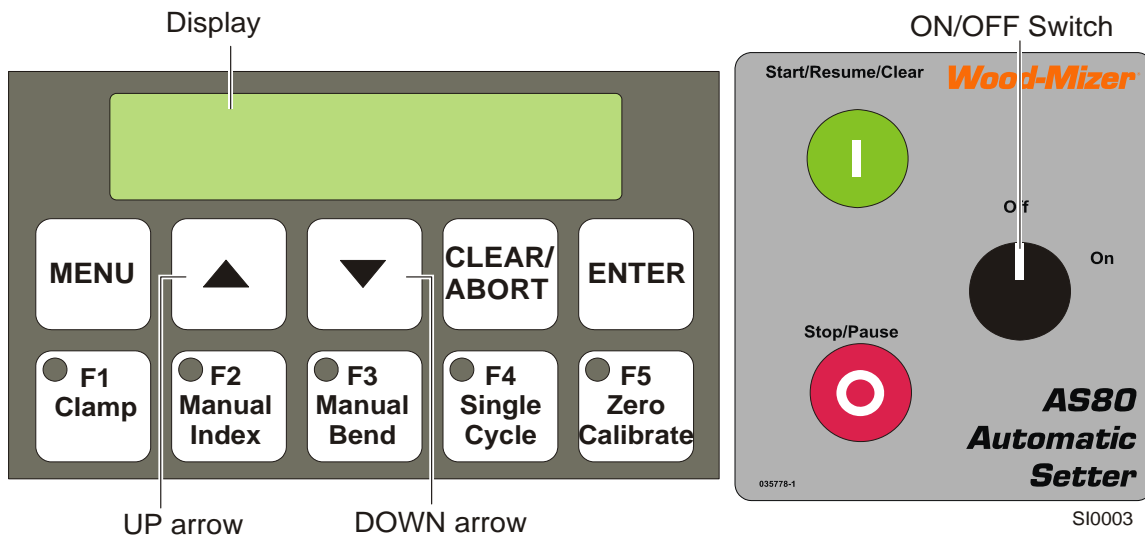

FIG. 1-2

On/Off Switch - turn the switch to the ON position to turn on electrical power to the machine.

Start/Resume/Clear - press to start or resume setting cycle; button also used to clear an error.

Stop/Pause - press to stop or pause machine.

Menu - press once to get to the menu.

Up arrow - press to select menu or option; used to increase values.

Down arrow - press to select menu or option; used to decrease values.

Clear/Abort - press once to clear the setting, cancel your action, or clear an error.

Enter - press once to confirm your choice.

F1 Clamp - press to close or open the blade clamp.

F2 Manual Index - press to move the blade to the next tooth.

F3 Manual Bend - used to bend the blade teeth manually regardless of set; the tooth set is not checked.

F4 Single Cycle - press to set the blade using the single cycle mode. The indexer pawl moves the blade. The blade is clamped and the tooth set is checked. The setter sets the tooth if necessary.

F5 Zero Calibrate - used during calibration of the blade clamp. [See Section 3.1 Setter Calibration.](#)

1.9 Start Up Modes

Press the MENU button once to get to the menu selection mode. Press the UP or DOWN button twice to find the MODE menu.

The following options are available in the MODE menu:

Set Single Clamp - The setter clamps and checks the blade tooth. The tooth is set if necessary. The blade is unclamped, and moved to the next tooth. The setter skips the pattern recognition while using the Set Single Clamp mode. The final tooth correction follows, i.e. if the tooth is unbent not enough - setter bend it, if the tooth is bended too much - setter unbend it.

Set Double Clamp - Just like using the Set Single Clamp mode, but the blade is clamped once more after releasing and checked for the tooth set. The pattern recognition is turned off. The Set Double Clamp mode is more accurate but more time-consuming.

Pattern Single Clamp - The mode similar with the Set Single Clamp mode, but the setter checks the teeth pattern. See System Parameters, for how to set the maximum number of pattern errors (only 1 in most cases). When the number of possible errors is exceeded, the setter stops the setting process and the "Error --- Blade Set Pattern" message appears.

Pattern Double Clamp - Using the Pattern Double Clamp mode, the setter works like using the Pattern Single Clamp mode, but the blade is released and clamped again to check the tooth set. The Pattern Double Clamp mode takes more time to set the whole blade but it is more accurate.

Inspection - After the Inspection mode has been selected, the setter checks the tooth set only. The process is stopped when the number of pattern errors has been exceeded.

NOTE: The Pattern Single Clamp and Pattern Double Clamp modes can be used only when the tooth setter has been set to push every tooth of the blade.

Push the ENTER button to select the mode you want the setter to operate.

1.10 Blade Settings

Press the MENU button on the control panel once to enter the BLADE SETTINGS mode. Use the UP or DOWN arrows if necessary. Push the ENTER button to enter the settings.

The following options are available in the BLADE SETTINGS menu:

No. of teeth to set - The number of teeth to be set. Press ENTER to see the "Qty Teeth To Set #" message. Use the UP and/or DOWN arrows to enter the number of teeth to be set. See **Table 1-1** below. **NOTE:** Enter the number of teeth divided by three if the setter pushes every third tooth of the blade.

Upper Set Limit - The desired tolerance for the upper set. When entered the "Upper Set Limit #" appears. Use the UP and/or DOWN arrows to set the limit value. The upper set limit is the upper limit of the tolerance for the blade tooth set. If the tooth set exceeds the upper limit, the setter adds the tooth to the group of teeth with the incorrect set. The setter stops when the number of set errors is exceeded.

Lower Set Limit - The desired tolerance for the lower set. When entered the "Lower Set Limit #" appears. Use the UP and/or DOWN arrows to set the limit value. The lower set limit is the lower limit of the tolerance for the blade tooth set. If the tooth set is below the limit, the setter adds the tooth to the group of teeth with the incorrect set. The setter stops when the number of set errors is exceeded.

Maximum Raker Set - The desired tolerance for raker set teeth. When entered the "Max. Raker Set #" appears. Enter the desired tolerance for rakers. Use the lowest possible tolerance that still allows the setter to efficiently operate. If the raker set exceeds the provided limit, the tooth set error appears.

1**General Information & Safety***Blade Settings*

See Table 1-4. Recommended blade settings are shown below.

Blade Type ¹	Blade Thickness	Number of teeth (standard blades) ²	Lower Set Limit (Value Entered)	Upper Set Limit (Value Entered)	Raker Set (Value Entered)
175 158 10 S	.035"	180	0.017" (17.0)	0.019" (19.0)	0.009" (9.0)
274 158 10 S	.042"	180	0.020" (20.0)	0.022" (22.0)	0.009" (9.0)
274 158 9 S	.042"	180	0.019" (19.0)	0.021" (21.0)	0.009" (9.0)
275 158 9 S	.042"	180	0.020" (20.0)	0.022" (22.0)	0.009" (9.0)
375 158 10 S	.045"	180	0.024" (24.0)	0.026" (26.0)	0.009" (9.0)
375 158 9 S	.045"	180	0.020" (20.0)	0.022" (22.0)	0.009" (9.0)
376 158 13 S	.045"	180	0.024" (24.0)	0.026" (26.0)	0.009" (9.0)
376 158 10 S	.045"	180	0.024" (24.0)	0.026" (26.0)	0.009" (9.0)
376 158 9 S	.045"	180	0.020" (20.0)	0.022" (22.0)	0.009" (9.0)
475 158 9 S	.055"	180	0.024" (24.0)	0.026" (26.0)	0.009" (9.0)
475 158 10 S	.055"	180	0.027" (27.0)	0.029" (29.0)	0.009" (9.0)
476 158 10 S	.055"	180	0.027" (27.0)	0.029" (29.0)	0.009" (9.0)
476 158 13 S	.055"	180	0.027" (27.0)	0.029" (29.0)	0.009" (9.0)
656 158 12 S	.038"	240	0.018" (18.0)	0.020" (20.0)	0.009" (9.0)

TABLE 1-4

¹ Only standard blade types are shown.

² Increase the number of teeth to be set by 1 or 2 to make sure all the teeth have been checked and set.

1.11 System Parameters

Press the MENU button once. Push the DOWN arrow button to find the SYSTEMS PARAMETERS menu. Press ENTER to see parameters needed to be set.

When selected, the following parameters can be set:

Max Tooth Set Errors¹ - push the ENTER button to enter the "Max Set Errors #" parameter. Use the UP and DOWN buttons to adjust the maximum number of teeth that can be set incorrectly in the setting process. When the number of errors is exceeded the setting process will be stopped. The "Error -- Bld !! Tooth Set #" message appears. The # mark is the current tooth set. **NOTE:** To decrease set, bend the tooth back with the slot in the correction tool provided. Press the green Start/Resume button to cancel the error. Push the F3 Manual Bend button to allow the setter to set the tooth again. To add set, press the F3 Manual Bend button.

Dpy Imperial/MM - when selected, the "Standard Selected" appears, followed by the current selection: Imperial or Metric. Use the UP and DOWN arrows to switch the units of measure. Press ENTER to confirm. **NOTE:** Always turn the setter off after changing the units of measure. Turn the setter on to use new units of measure.

1. Number of the straightening teeth cylinder cycles. It allows to limit too many cylinders hits (it is used when the teeth is broken, damaged or it is hard to set it.)

1.12 Diagnostic & Setup

To enter the DIAGNOSTIC/SETUP menu, press the MENU button. Press the UP arrow once, and push ENTER to confirm. Use the UP and DOWN arrows to switch options.

The following options are available in the DIAGNOSTIC/SETUP menu:

Raw A/D value - technical specifications.

Current Zero Cal. - technical specifications.

Right Index Prox - indicates the right indexer proximity sensor status: ON or OFF.

Left Index Prox - indicates the left indexer proximity sensor status.

Indexer Home Prox - indicates the indexer cam proximity sensor status.

Cam Home Prox - indicates the drive cam proximity sensor status.

Linear Sensor Adjust - indicates the linear sensor adjustment status. [See Section 4.1 Sensor Adjustment](#), for the adjustment procedure.

System Tooth Counter - indicates the total number of blade teeth processed. The bottom line shows the last four digits of the number. The upper line shows the first digits of the number. Example: High Count 3, Low Count is 2117 - 32.117 teeth have been processed.

Push the ENTER button after selection is complete to check the option status.

1.13 Power Supply Specification

The power supply must meet the specifications given below.

Voltage	Fuse [A]	Suggested Wire Size
230 VAC	2 A	1.5 mm at least

TABLE 1-0

SECTION 2 OPERATION

2.1 Machine Setup

1. Install the blade to the setter. Rest the blade on the inside of the two blade guides and in between both blade clamps. Center the blade on the setter stand. Position the three adjustable blade guide supports so they lightly touch the inside of the blade. The adjustable guides should lightly support the blade and keep it from wobbling.
2. Use the blade height knob to adjust the blade height so the bottom of the gullet is aligned with the top of the blade clamps.

See Figure 2-1.

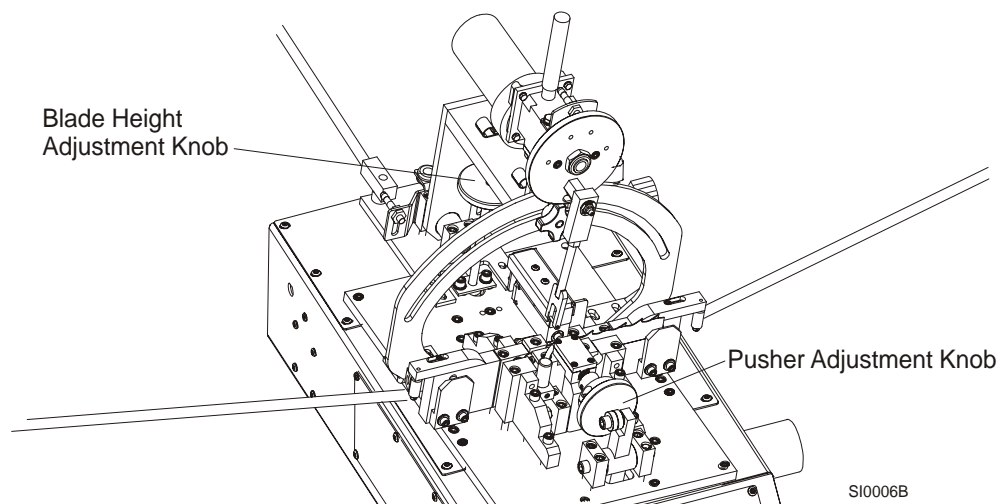

FIG. 2-1

3. Adjust the pusher pin. To adjust, manually rotate the pusher adjustment knob. Turn the pusher adjustment knob clockwise to increase the pusher pin force, turn the knob counterclockwise to decrease the force. Make sure the tooth is not being bent too much. Read the display to check the tooth set while adjusting.

IMPORTANT! Avoid pinching fingers or hand when turning the cam.



DANGER! Keep all persons away from moving parts when operating this machine. Failure to do so will result in serious injury.

4. Adjust the index ramp. The push pawl should push one tooth at a time. To adjust, loosen the blade ramp set screw. Slide the blade ramp as necessary and retighten the set screw.

The pawls should contact the point of the tooth where the face and gullet meet. Manually rotate the index cam until the pawl is against the tooth radius. Loosen the index pawl adjustment nut to position the pawl as necessary. Retighten the nut when adjustment is complete.

2.2 Preliminary Setup

1. Clean the machine as needed with a solution of 1 part liquid Dawn detergent to 9 parts water. Use an air hose to blow any dust or debris from the blade clamp and up/down components.



WARNING! Never use WD-40 or any other non-specified lubricant to clean the machine.

Keep liquid away from the sensor assembly.

2. Make sure the voltage selector plate is set properly before turning on electrical power to the setter.
3. Plug the power cord in the socket at the rear of the setter.
4. Locate the air assembly at the rear right side of the setter. Connect the incoming air supply line to the fitting. Make sure the air gauge indicates 60 P.S.I. Adjust the pressure if needed. To adjust the pressure, lift the black cap located behind the air gauge. Turn the cap clockwise to increase pressure, turn the cap counterclockwise to decrease pressure. Push the cap down to secure when adjustment is complete.

See Figure 2-2.



FIG. 2-2

5. Turn the ON/OFF switch to the ON position.
6. Calibrate the setter if necessary. [See Section 3.1 Setter Calibration.](#)
7. Make all the adjustments necessary to start the setting operation. [See Sections 1.6 through 1.8.](#)

2.3 Machine Operation

1. Clean the blade and deburr before putting in the toothsetter. Otherwise, sap buildup on the blade or tooth will give false set readings. Metal burrs created by sharpening will also cause false readings.
2. Mount the blade in the toothsetter. Place blade between the clamping plates and on the three guide assemblies. Use the weld as a reference point for starting.

See Figure 2-3. Position the tooth in front of the sensor pin so its edge is approximately .0625" (1.6mm) away from the edge of the pusher pin.

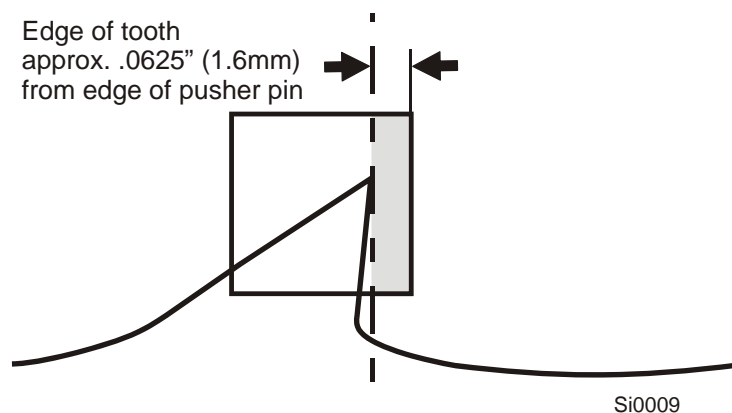

FIG. 2-3

3. Turn the ON/OFF switch to the ON position.
4. Now all of the adjustments have been made. Push START to begin the setting operation. All values will remain as set.
5. Toothsetter works automatically.

To adjust the pusher adjustment knobs, push the CLAMP button. Tooth bend value will appear on the display. This value should be between upper and lower set limit. If, it will be smaller, turn the pusher adjustment knob to adjust as small value as possible. Next, hold down the Manual Bend button and observe display readings. Increase tooth tilt by adjusting the knob.

If the unbended tooth value is between upper and lower set limit, push the START button. Tooth will be setting automatically.

(Repeated bending of the same tooth can occur. During the setting operation, tooth bend value should be corrected by using the pusher adjustment knob.)

2

Operation

Machine Operation

6. The machine will automatically stop after the setting operation has been completed.
7. Remove the blade and invert it.
8. Swing the index motor assembly to the other side. Repeat the setting operation.

SECTION 3 MAINTENANCE

3.1 Setter Calibration

To calibrate:

1. Clean each clamp block with air. If oily, wipe dry with a clean rag.



WARNING! Never spray a liquid on or near the sensor assembly.

2. Inspect the blocks for chips and/or other damage. Replace if necessary.
3. Place the calibration plate into the clamp assembly. Position the calibration plate so the top of the plate is slightly above the top of the sensor pin.
4. Press the F1 Clamp button on the control panel to clamp the calibrate plate.
5. Press the F5 Zero Calibrate button to calibrate the setter.

NOTE: If the "Error -- CAL Clamp Zero CAL Block" message appears, you need to adjust the sensor first. [See Section 4.1 Sensor Adjustment](#), for the adjustment procedure.

6. With the calibration plate still clamped, manually retract the sensor pin and insert the .024" diameter gauge pin between the calibration plate and the sensor pin. If the display does not indicate .024 (± 0.001), the sensor is malfunctioning and should be replaced.
7. Hold the calibrate plate with the tips of your fingers. Press the F1 Clamp button to unclamp the calibration plate. Remove the calibration plate.

3.2 Miscellaneous

1. Check the chain every 40 hours of operation. Lubricate if needed.
2. Check chain tension periodically. Adjust the chain tension if necessary.
3. Grease the threads on the up/down height adjustment rods with a heavy axle grease every 40 hours of operation.

SECTION 4 ALIGNMENT

Check and align the setter each time the linear sensor is replaced.

4.1 Sensor Adjustment

1. Turn the ON/OFF switch to the ON position.
2. Check the air pressure. Make sure the air pressure gauge indicates 60 P.S.I. Adjust the pressure if necessary.
3. Place the calibration plate in the setter clamp assembly. (Use the appropriate calibration plate as thick as the blade you want to set.) Keep the upper edge of the plate and the sensor pin level.
4. Press the MENU button. Push the UP arrow once to enter the DIAGNOSTIC/SETUP menu and press the ENTER button. Press the UP button once to select the LINEAR SENSOR ADJUST menu. Press ENTER again to confirm.

See Figure 4-1. The sensor is adjusted properly if the black mark is located between the arrows on the display.

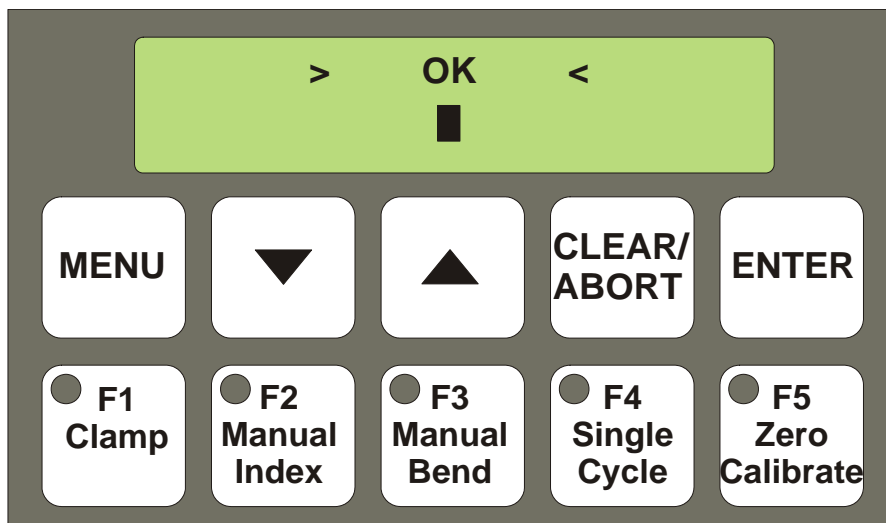

SI0002-1

FIG. 4-1

NOTE: If the black mark is not located between the arrows, the sensor needs adjustment.

5. Remove the two screws securing the sensor guard and remove the sensor guard.

See Figure 4-2.

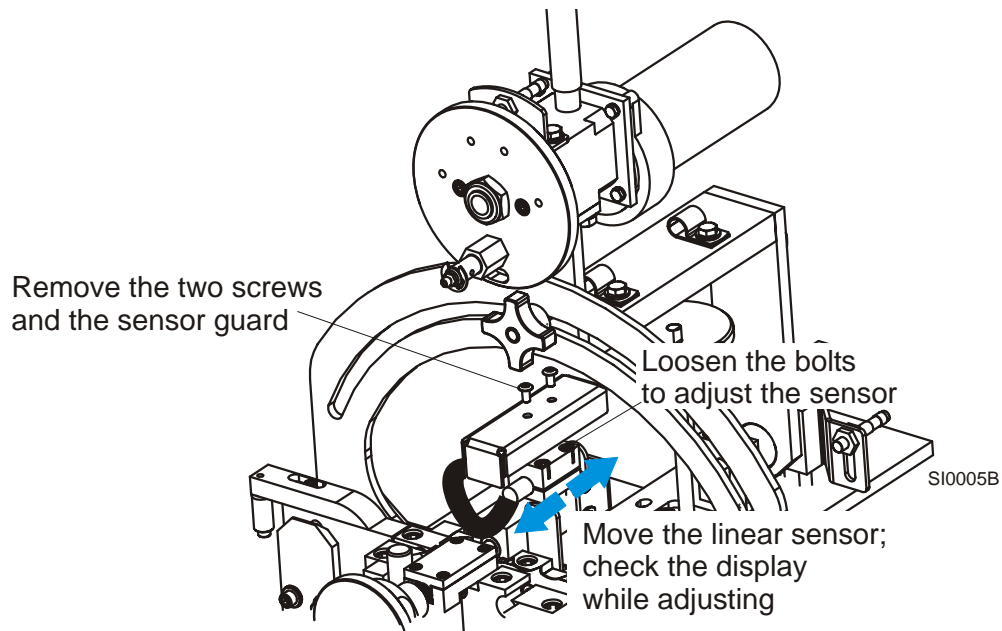

FIG. 4-2

6. Loosen the two bolts securing the linear sensor. Move the linear sensor back and forth to place the black mark between the arrows on the display.
7. Tighten the mounting screws to secure the linear sensor when adjustment is complete.
8. Press CLEAR/ABORT to leave the adjustment option.

SECTION 5 TROUBLESHOOTING

5.1 Error Messages

See Table 5-1. The possible error messages and their causes are listed below:

MESSAGE	CAUSE	SOLUTION
Error --- A/D A/D Failure	Power supply failure. A/D module has broken. Linear sensor is out of range.	Check connecting cable. Check the A/D module connections. Replace if necessary. Adjust the linear sensor. See Section 4.1
Error --- IDX Home Sensor	Circuit breaker failure. Proximity sensor is not adjusted. Index motor is not plugged.	Check the 3 Amp circuit breaker located at rear of the setter. Turn on the circuit breaker or replace if necessary. Adjust the proximity sensor. Plug the indexer motor.
Error --- IDX Not Fully Seated	Indexer is not seated properly. (Proximity sensor light is off).	Adjust the indexer assembly. Check if the proximity sensor light is on.
Error --- CAM Home Sensor	Circuit breaker failure. Cam proximity sensor not adjusted Cam motor is unplugged.	Check the 3 Amp circuit breaker located at rear of the setter. Reset the circuit breaker or replace if necessary. Adjust cam proximity sensor. Check if the proximity sensor light is on. Plug the cam motor.
Error --- Cal Clamp Zero CAL Block	While calibrating: metal pattern block is not clamped.	Clamp the metal pattern block to adjust the sensor pin.
Error --- Cal Sensor Out of Range	Linear sensor is out of range.	Adjust the linear sensor. See Section 4.1
Error -- Sensor Return Zero	Sensor pin is stuck.	Inspect the sensor pin. Clean the sensor if necessary.
Error --- Bld Tooth Set	Tooth set is incorrect.	Adjust the pusher. Inspect the blade.
Error --- Bld Set Pattern	Tooth set pattern is not correct.	Inspect the blade teeth. Correct the teeth pattern.
Lower Set Limit >= Upper Set Limit	Lower tooth set limit is above the upper limit.	Increase the upper tooth set limit. OR decrease the lower tooth set limit.
Raker Limit >= Lower Set Limit	Raker limit is above the lower limit.	Increase the lower tooth set limit. OR decrease the raker tooth set limit.

TABLE 5-1

SECTION 6 REPLACEMENT PARTS

6.1 Pivoting Index Motor Assembly

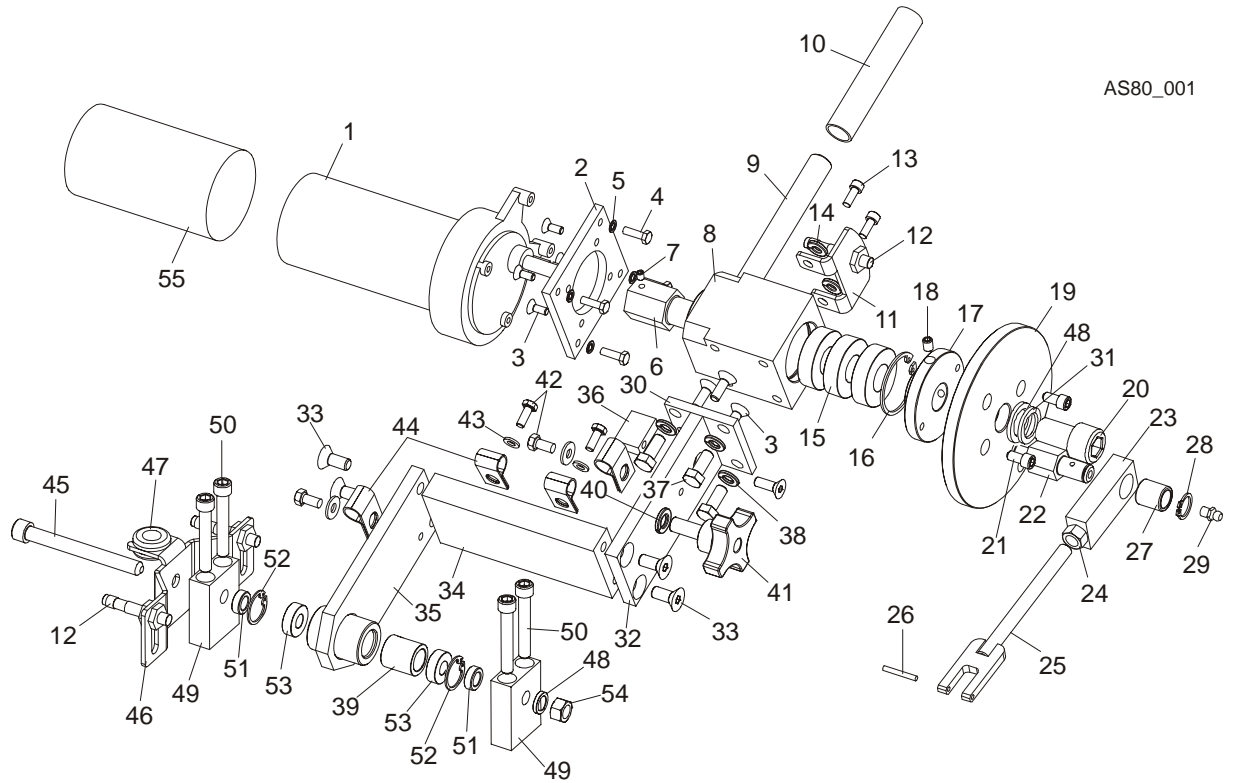

REF	DESCRIPTION (◆ Indicates Parts Available In Assemblies Only)	PART #	QTY.
	INDEX ASSEMBLY, PIVOTING	101390	1
1	MOTOR ASSEMBLY, 24V 60RPM GEAR	035659	1
2	PLATE, MOTOR MOUNT	101382-1	1
3	SCREW, M6X20-10.9 FE/ZN5 DIN-7991	F81001-17	8
4	BOLT, #10-32 X 5/8" HEX HEAD	F05004-152	4
5	WASHER, 5.1 SPLIT LOCK ZINC	F81052-2	4
6	SHAFT, AS80 DRIVE	101381-1	1
7	SCREW, M4X6 ISO4028 SET	F81014-6	2
8	HOUSING, AS80 BEARING	101383-1	1
9	HANDLE, INDEX PIVOT	500040-1	1
10	GRIP, HANDLE 1/2IDX3 LG	014835	1
11	BRACKET, INDEX PROXIMITY SENSOR	101394-1	1
12	SENSOR, BESM08MI-PSC20B-BV02 PROXIMITY	500456	3
13	SCREW, M6X16, HEX SOCKET HEAD CAP	F81001-21	2
14	WASHER, 6.4 FLAT ZINC	F81053-1	2

6

REPLACEMENT PARTS*Pivoting Index Motor Assembly*

15	BEARING, 6004 2RS CX ROLLING	093868	3	
16	RING, W40 SPRING RETAINING	F81090-3	1	
17	PLATE, CAM	101385-1	1	
18	SCREW, M6x10-45H Fe/Zn5 PN84/M-82314 SET	F81001-26	2	
19	Plate, AS80 Cam	101393-1	1	
20	BOLT, M10 X 25 8.8, PN-M/82302	F81003-32	1	
21	SCREW, M6X10 8.8 HEX SOCKET HEAD CAP ZINC	F81001-12	2	
22	SHAFT, AS80 INDEX PIVOT	500041	1	
	PAWL ASSY, AS80 PUSH	500047	1	
23	BLOCK, AS80 PUSH PAWL	500046-1	1	
24	NUT, M10-8-B-FE	F81033-3	1	
25	PAWL WELDMENT, AS80 PUSH	500045-1	1	
26	PIN, 3m6x24 DIN6325 HRC60 ROLL	F81048-9	1	
27	BEARING, 16/12-19 AS80	500042	1	
28	RING, Z12 OUTSIDE RETAINING	F81090-14	1	
29	FITTING, M6 GREASE	086280	1	
30	PLATE, MOTOR MOUNT	500048-1	1	
31	WASHER, 10.2 SPLIT LOCK ZINC	F81055-2	1	
32	PLATE, UPPER INDEX SUPPORT	500049-1	1	
33	BOLT, M8X30-8.8-FE/ZN5 DIN 7991	F81002-43	4	
34	SPACER, INDEX ARM	500087-1	1	
35	ARM WLDMNT, INDEX PIVOT	500089-1	1	
36	BLOCK, INDEX MOTOR SUPPORT	500050-1	1	
37	BOLT, M8X16 -8.8-B-FE/ZN5 PN-85/M-82105	F81002-20	4	
38	WASHER 8,2 FE/ZN9	F81054-4	4	
39	SPACER, 22/18-17.5 AS80 BEARING	101380	1	
40	WASHER, 8.5 SPLIT LOCK ZINC	F81054-11	1	
41	KNOB, SR50/M8x25 (466406 MOSS) THRU HOLE	500973	1	
42	BOLT, M6 X 16 8.8 FE/ZN5 PN-M/82105	F81001-15	3	
43	WASHER, 6.4 FLAT ZINC	F81053-1	3	
44	CLAMP, 1/2 EMT COATED	P07584	3	
45	BOLT, M10X95-8.8-B HEX HEAD ZINC	F81003-71	1	
46	BRACKET, INDEX PIVOT HOME	095845-1	1	
47	GROMMET, 20/13 RUBBER	086188	1	
48	WASHER, 10.5 FLAT ZINC	F81055-1	2	
49	BLOCK, INDEX ARM PIVOT	101369-1	2	
50	SCREW, M8X60 SOCKET HEAD	F81002-41	4	
51	SPACER, 15/10.2-8 BEARING ZINC	101372-1	2	
52	RING, W22 RETAINING	F81090-7	1	
53	BEARING, 61900-2RSI ROLLING	101371	2	
54	NUT, M10-8-B-FE	F81033-3	1	
55	CAP, 2.5ID x 3 RUBBER	023720	1	

6.2 Cam Drive Unit Assembly

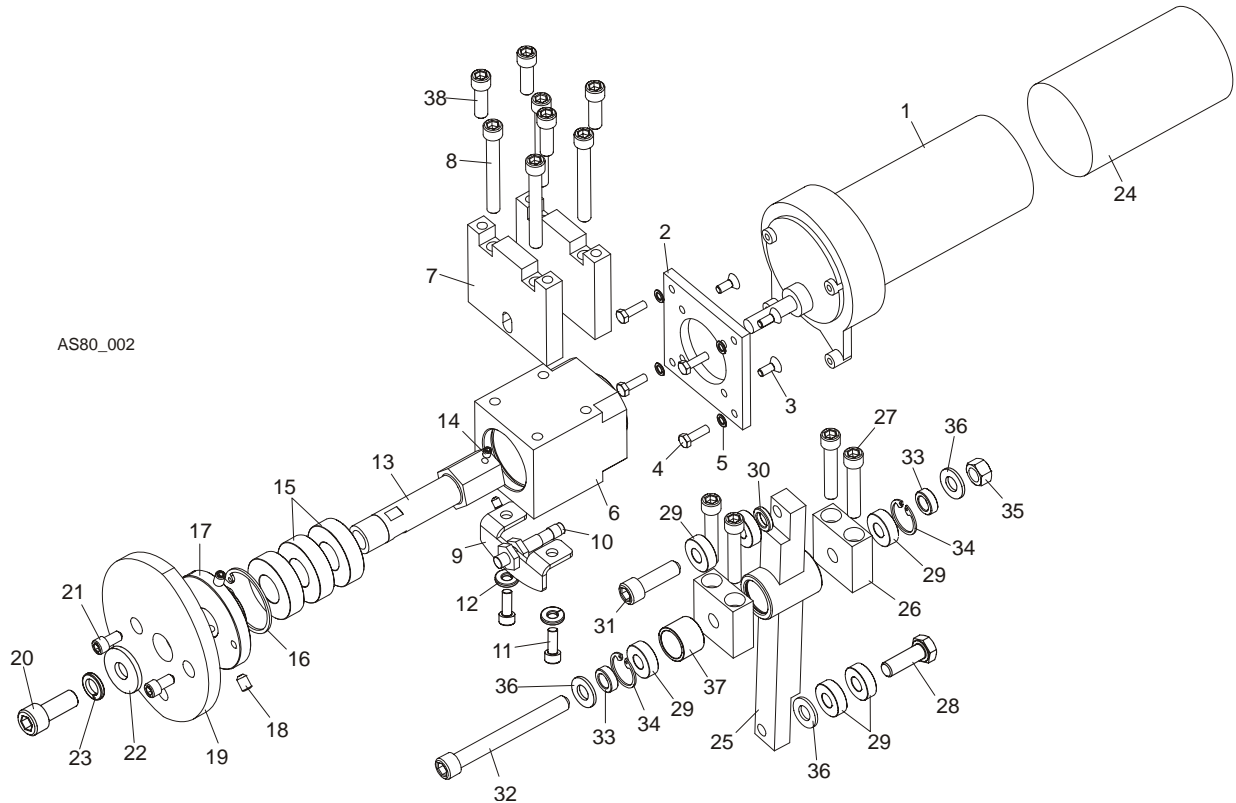

REF	DESCRIPTION (◆ Indicates Parts Available In Assemblies Only)	PART #	QTY.
	CAM DRIVE ASSEMBLY, AS80	101387	1
1	MOTOR ASSEMBLY, 24V 60 RPM GEAR	035659	1
2	PLATE, AS80 MOTOR MOUNT	101382-1	1
3	SCREW, M6X20-10.9 FE/ZN5 DIN-7991	F81001-17	4
4	BOLT, #10-32 X 5/8" HEX HEAD	F05004-152	4
5	WASHER, 5.1 SPLIT LOCK ZINC	F81052-2	4
6	HOUSING, AS80 BEARING	101383-1	1
7	RISER, CAM HOUSING	101384-1	1
8	SCREW, M8X65-8.8-FE/ZN5 PN/M 82302 SOCKET HEAD	F81002-45	4
9	BRACKET, INDEX PROXIMITY	101388-1	1
10	SENSOR, BESM08MI-PSC20B-BV02 PROXIMITY	500456	1
11	SCREW, M6X16, HEX SOCKET HEAD CAP	F81001-21	2
12	WASHER, 6.4 FLAT ZINC	F81053-1	2
13	SHAFT, AS80 DRIVE	101381-1	1
14	SCREW, M4X6 ISO4028 SET	F81014-6	2
15	BEARING, 6004 2RS CX ROLLING	093868	3

6

REPLACEMENT PARTS*Cam Drive Unit Assembly*

16	RING, W40 SPRING RETAINING	F81090-3	1	
17	PLATE, CAM	101385-1	1	
18	SCREW, M6x10-45H Fe/Zn5 PN84/M-82314 SET	F81001-26	2	
19	CAM, AS80 SET	101386-1	1	
20	SCREW, M10x25 8.8 HEX SOCKET HEAD CAP ZINC	F81003-32	1	
21	SCREW, M6x10 8.8 HEX SOCKET HEAD CAP ZINC	F81001-12	2	
22	WASHER, 10.5 ZINC FLAT SPECIAL	F81055-6	1	
23	WASHER, 10.2 SPLIT LOCK ZINC	F81055-2	1	
24	CAP, 2.5ID x 3 RUBBER	023720	1	
	ARM ASSEMBLY, PUSHER PIVOT	101378	1	
25	ARM WELDMENT, CAM PIVOT	101377-1	1	
26	BLOCK, PIVOT	101369-1	2	
27	SCREW, M8X60 SOCKET HEAD ZINC	F81002-41	4	
28	BOLT, M10X30-5.8 HEX HEAD FULL THREAD ZINC	F81003-2	1	
29	BEARING, 61900-2RSI ROLLING	101371	6	
30	SPACER, 15/10.2-5 BEARING	101379-1	2	
31	SCREW, M10x35 SOCKET HEAD ZINC	F81003-56	1	
32	BOLT, M10x95-8.8-B HEX HEAD ZINC	F81003-71	1	
33	SPACER, 15/10.2-8 ZINC	101372-1	2	
34	RING, W22 RETAINING	F81090-7	2	
35	NUT, M10-8-B-FE	F81033-3	1	
36	WASHER, 10.5 FLAT ZINC	F81055-1	2	
37	SPACER, 22/18-17.5 BEARING	101380	1	
38	BOLT, M8 X 20-8.8 SOCKET HEAD	F81002-30	4	

6.3 Front & Back Clamp Assembly

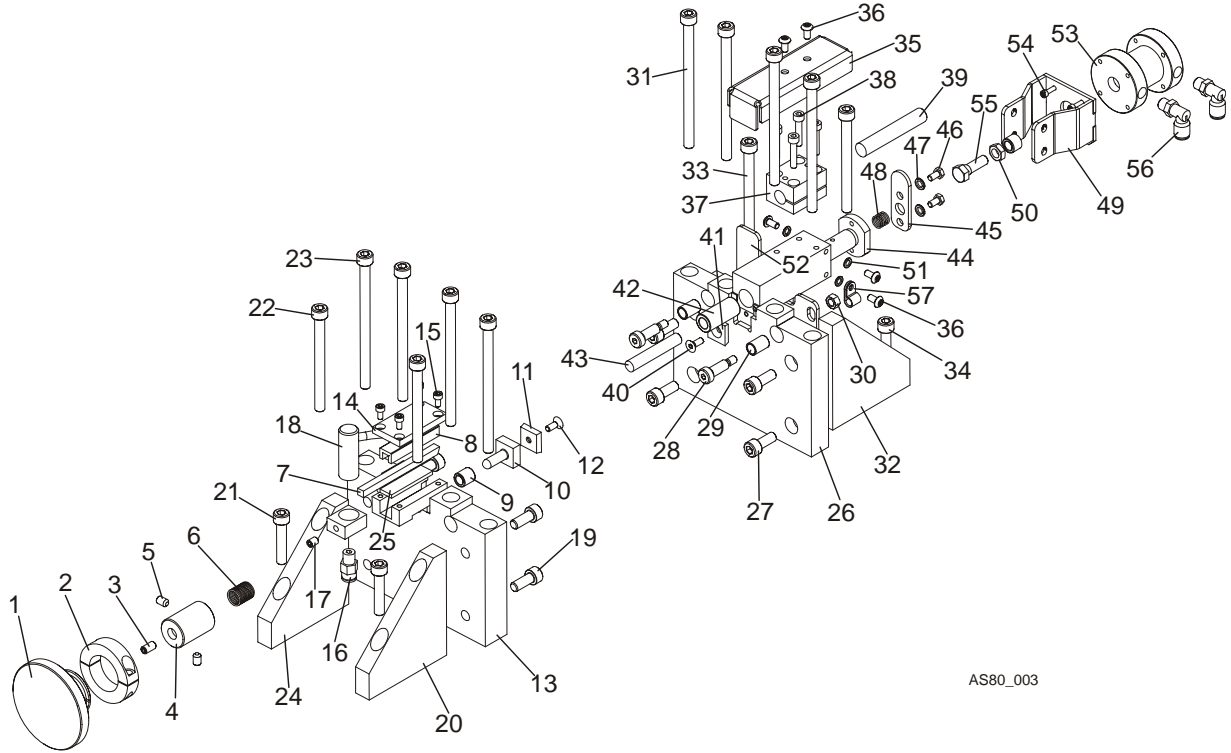

AS80_003

REF	DESCRIPTION (◆ Indicates Parts Available In Assemblies Only)	PART #	QTY.
	CLAMP ASSEMBLY, AS80 FRONT	101361	1
1	KNOB, SET ADJUSTER	035467	1
2	COLLAR, 1-1/4 I.D. 2-PIECE CLAMPING	035468	1
3	SCREW, 1/4-20 X 1/2" SOCKET HEAD NYLON LOCK	F05005-55	1
4	HOLDER, PUSH PIN	035465	1
5	SCREW, 1/4-20X3/8 SHCP SET	F05005-47	2
6	SPRING, .6 DIA COMPRESSION .510 ID X 3/4	032377	1
7	PIN, PUSHER (RESHARP)	032362	1
8	BRACKET, PUSHER PIN CHANNEL	032361	1
9	BUSHING, 5/16" ID X 1/2" OD X 1/2" DRILL JIG	P32076	1
10	PIN, CLAMP	S32018	1
11	INSERT, 3/4" CARBIDE CLAMPING	P32010	1
12	BOLT, #10-24 X 1/2" FLAT SOCKET HEAD	F05004-61	1
13	CLAMP WLDMT, FRONT	101360	1
14	PLATE, PUSHER TOP SAS	101364-1	1
15	BOLT, #8-32 X 3/8" SOCKET HEAD	F81011-36	4
	BLOWOFF ASSEMBLY	032337	1
16	FITTING, 1/8" NPT X 1/4" TB	P03078	1

6

REPLACEMENT PARTS*Front & Back Clamp Assembly*

17	SCREW, M6X8 SET	F81013-1	1	
18	BLOWOFF, AIR ASSEMBLY	032336	1	
19	BOLT, M8 X 20-8.8 SOCKET HEAD	F81002-30	4	
20	GUSSET, CLAMP SUPPORT	500175-1	2	
21	SCREW, M8X40-8.8 HEX SOCKET HEAD CAP ZINC	F81002-29	2	
22	SCREW, M8X90-8.8 HEX SOCKET HEAD CAP ZINC	F81002-44	2	
23	SCREW, M8X120-8.8 HEX SOCKET HEAD CAP ZINC	F81002-40	4	
24	GUSSET, CLAMP SUPPORT W/BLOWOFF SUPPORT	101363-1	1	
25	PLATE, LOWER WEAR	032360	1	
	CLAMP ASSEMBLY, AS80 BACK	101346	1	
26	CLAMP WELDMENT, AS80 BACK	101163-1	1	
27	BOLT, M8 X 20-8.8 SOCKET HEAD	F81002-30	4	
28	BOLT, 8/MX20 12.9	F81001-25	2	
29	SPRING, .75" LTH COMPRESSION	P32011	2	
30	NUT, M6, HEXAGON,FREE, GRADE 5(8.8)ZINC	F81031-1	2	
31	SCREW, M8X120-8.8 HEX SOCKET HEAD CAP ZINC	F81002-40	4	
32	GUSSET, CLAMP SUPPORT	500175-1	2	
33	SCREW, M8X90-8.8 HEX SOCKET HEAD CAP ZINC	F81002-44	2	
34	SCREW, M8X40-8.8 HEX SOCKET HEAD CAP ZINC	F81002-29	2	
35	GUARD, TOP SENSOR	101168-1	1	
36	BOLT, M5X10 WG. ISO 7380	F81000-32	4	
37	BLOCK, SENSOR MOUNT	101167-1	1	
38	BOLT, M5 X 25-5.8-FE/ZN5, PN-M/82302	F81000-7	4	
39	PROXIMITY SENSOR, BAWM12 INDUCTIVE SHID	500457	1	
40	BOLT, #10-24 X 1/2" FLAT SOCKET HEAD	F05004-61	1	
41	INSERT, 3/4" CARBIDE CLAMPING	P32010	1	
42	BUSHING, 3/8" X 5/8" X 1 3/8" DRILL	032352	1	
	PIN ASSEMBLY, AS80 SENSOR	035783	1	
43	PIN, SENSOR	032354	1	
44	PIN, REAR LINEAR	035782	1	
45	PIN ASSEMBLY, AS80 SENSOR	101345-1	1	
46	SCREW, 10-24 X 3/8" HEX HEAD	F05004-150	4	
47	WASHER, Z6.1 SPLIT LOCK ZINC	F81053-3	2	
48	SPRING, .75 LTH COMPRESSION	P32011	1	
49	SUPPORT, CYLINDER	101171-1	1	
50	NUT, 5/16-24 JAM	F05010-205	2	
51	WASHER, 5.1 SPLIT LOCK ZINC	F81052-2	2	
52	PLATE, BLADE RELEASE	101165-1	1	
53	CYLINDER, 1 1/16 BORE AIR	P32055	1	
54	SCREW, 6-32X1/2 SHC	F05004-23	4	
55	BOLT, 5/16-24X1 HH	F05006-11	1	
56	FITTING, 1/8MPTX1/4 TUBE, ELBOW, SWIVEL	P09736	2	
57	ELEMENT, EE63 (112-312000) SELF - ADHESIVE MOUNT	F81080-4	1	

6.4 Cylinder Clamp Assembly

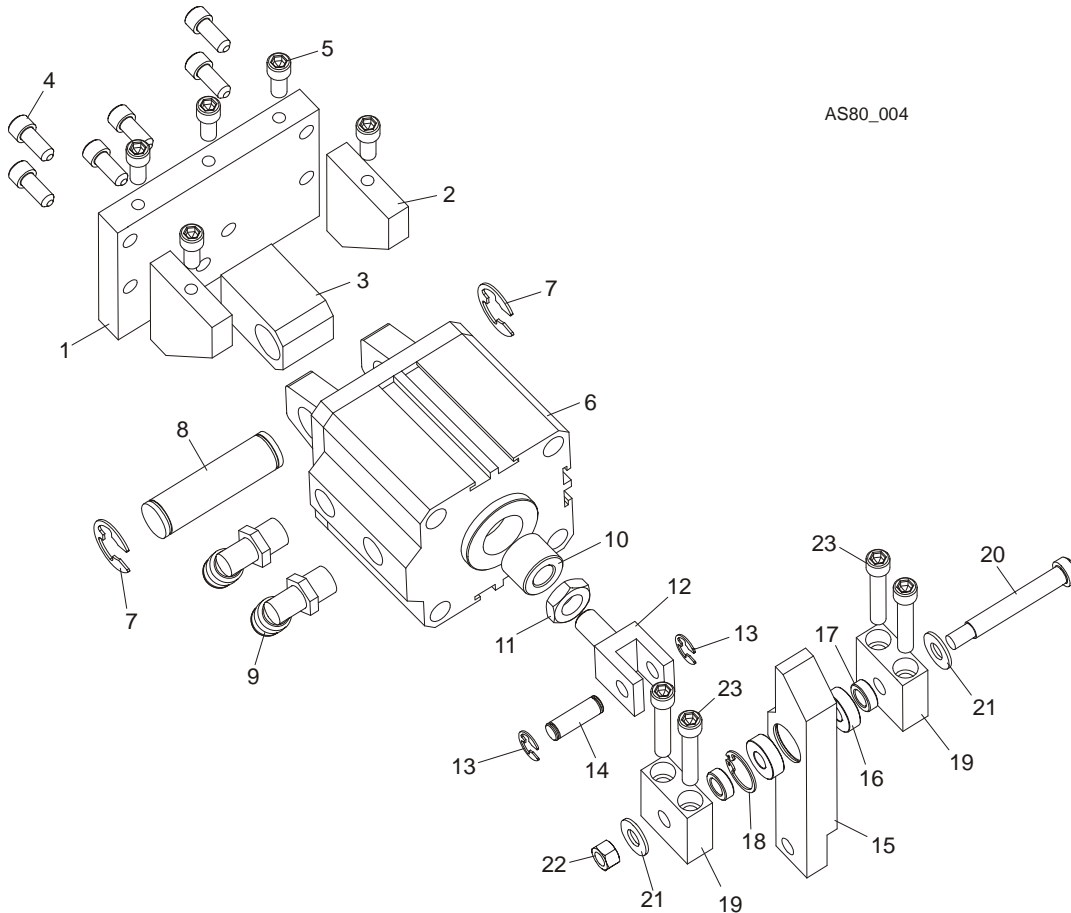

REF	DESCRIPTION (◆ Indicates Parts Available In Assemblies Only)	PART #	QTY.
	MOUNT ASSEMBLY, CYLINDER	101368	1
1	PLATE, PIVOT	101366-1	1
2	GUSSET, CLAMP CYLINDER	101367-1	1
3	BLOCK, PIVOT	101365-1	1
4	BOLT, M8 X 20-8.8 SOCKET HEAD	F81002-30	6
5	BOLT, M8 X 20-8.8 SOCKET HEAD	F81002-30	5
6	CYLINDER ASSEMBLY, CLAMP	032919	1
7	RING, RETAINING	P32034-5	2
8	PIN, CYLINDER	P32034-4	1
9	FITTING, 3/8" NPT X 3/8" 90° AIR	P21526	1
10	BUSHING, CYLINDER	P32034-2	1
11	NUT, 1/2-13 HEX JAM	F05010-31	1
12	BLOCK, CLEVIS	S32081	1

6

REPLACEMENT PARTS*Cylinder Clamp Assembly*

13	E-CLIP, 3/8" SHAFT	P10689	1	
14	PIN, CLEVIS	S32083	1	
	ARM ASSEMBLY, CLAMP	101373	1	
15	ARM, CLAMP PIVOT	101370-1	1	
16	BEARING, 61900-2RSI ROLLING	101371	2	
17	SPACER, 15/10.2-8 BEARING ZINC	101372-1	2	
18	RING, W22 RETAINING	F81090-7	1	
19	BLOCK, PIVOT	101369-1	2	
20	BOLT, 10/M8X60-12.9 ISO 7379 ZINC	F81003-79	1	
21	WASHER, 10.5 FLAT ZINC	F81055-1	2	
22	NUT, M8-8-B HEX NYLON ZINC LOCK	F81032-2	1	
23	SCREW, M8x60 SOCKET HEAD	F81002-41	4	

6.5 Air Regulator Assembly

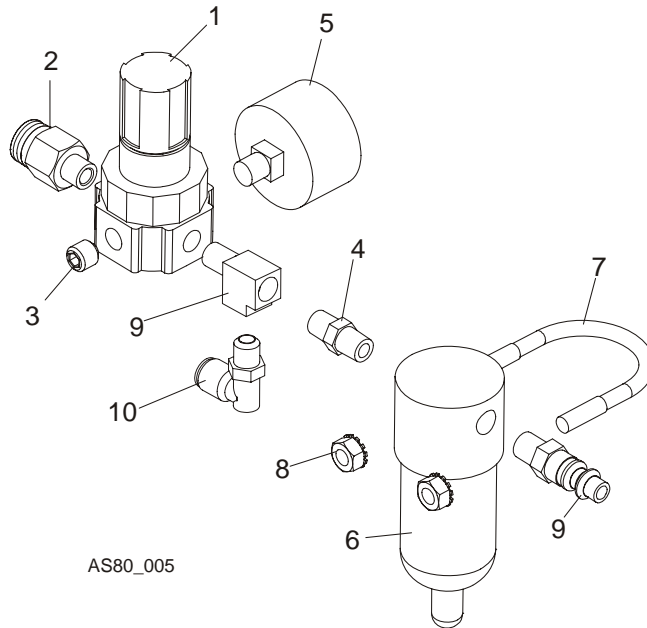

AS80_005

REF	DESCRIPTION (◆ Indicates Parts Available In Assemblies Only)	PART #	QTY.
	TOOTHSETTER PNEUMATICS KIT	035524	1
1	COUPLING, 1/8 NPT MALE AIR	P22681	1
2	FITTING, 1/8NPTX3/8 TUBE STRAIGHT	P21553	1
3	REGULATOR, R384-01C 300PSI AIR FLOW	P02765	1
4	NIPPLE, 1/8 DRY SEAL	P02764	1
5	GAUGE, 160 PSI	P02766	1
6	FILTER, #F504-01AH	P02769	1
7	U-BOLT, 1 9/16 ID	S03062	1
8	NUT, 1/4-20	F05010-9	2
9	FITTING, 1/8NPT STREET TEE	032161	1
10	FITTING, 1/8MPTX 1/4 TUBE, ELBOW, SWIVEL	P09736	1

6 REPLACEMENT PARTS

Rear Adjuster, Blade Height, Index Ramp Assemblies

6.6 Rear Adjuster, Blade Height, Index Ramp Assemblies

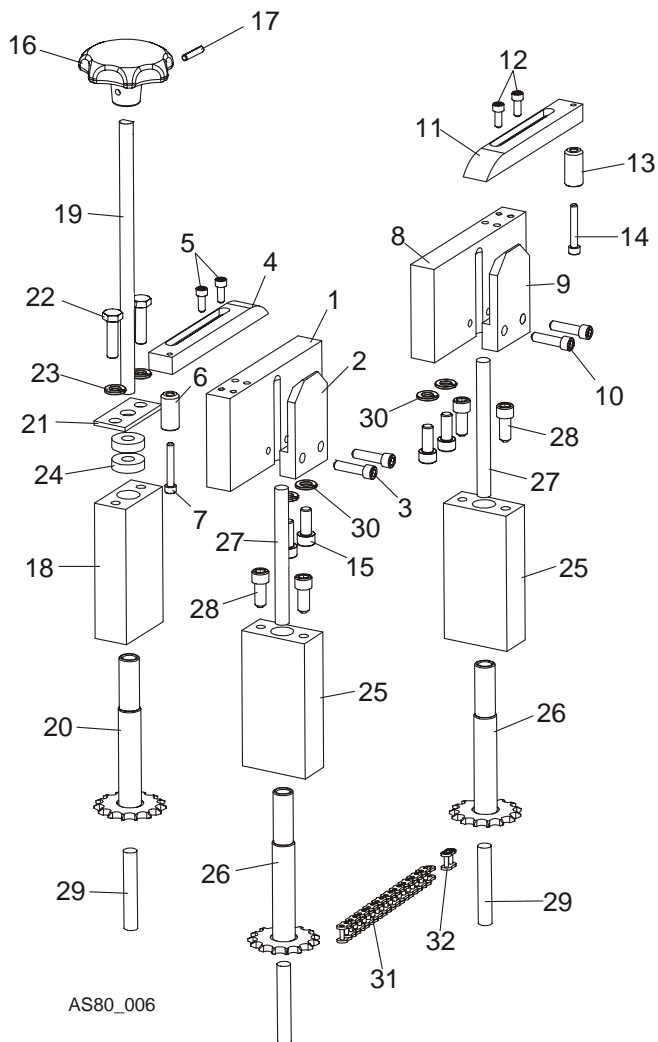

REF	DESCRIPTION (◆ Indicates Parts Available In Assemblies Only)	PART #	QTY.
	BLOCK ASSEMBLY, AS80 INDEX LEFT	101350	1
1	BLOCK, AS80 INDEX	101349-1	1
2	BLOCK, AS80 BLADE GUIDE	101353-1	1
3	SCREW, M6X30-8.8 SOCKET HEAD	F81001-42	2
4	RAMP, AS80 INDEX LEFT	101351	1
5	SCREW, M4X20 8.8 FE/ZN5 HEX SOCKET HEAD	F81011-31	2
6	PIN, BLADE WEAR	S32105	1
7	SCREW, M5X35 8.8 SOCKET HEAD	F81000-73	1
	BLOCK ASSEMBLY, AS80 INDEX RIGHT	101355	1
8	BLOCK, AS80 INDEX	101349-1	1

REPLACEMENT PARTS

Rear Adjuster, Blade Height, Index Ramp Assemblies

6

9	BLOCK, AS80 BLADE GUIDE	101353-1	1	
10	SCREW, M6X30-8.8 SOCKET HEAD	F81001-42	2	
11	RAMP, AS80 INDEX RIGHT	101354	1	
12	SCREW, M4X20 8,8 FE/ZN5 HEX SOCKET HEAD	F81011-31	2	
13	PIN, BLADE WEAR	S32105	1	
14	SCREW, M5X35 8.8 SOCKET HEAD	F81000-73	1	
15	BOLT, M8 X 20-8.8 SOCKET HEAD	F81002-30	4	
	BLOCK ASSEMBLY, AS80 REAR BLADE HEIGHT ADJUSTMENT	101158	1	
16	KNOB, BLADE HEIGHT ADJUSTMENT	098514	1	
17	PIN, ISO8752-4X20 ST AOP ROLL	F81044-11	1	
18	BLOCK, HEIGHT ADJUSTMENT	101152-1	1	
	IDLE SIDE WELDMENT	101154-1	1	
19	STUD, THREADED ROD	101153	1	
20	SPROCKET, 06B-1 Z15	101151	1	
21	PLATE, WASHER RETAINER	101159-1	1	
22	BOLT M8X30-8.8	F81002-7	2	
23	WASHER, 8.4 FLAT ZINC	F81054-1	2	
24	WASHER, 3/8" ID X 7/8" OD X 1/4" FELT	P32102	2	
	BLOCK ASSEMBLY, BLADE HEIGHT ADJUSTMENT	101156	2	
25	BLOCK, HEIGHT ADJUSTMENT	101152-1	2	
26	IDLE SIDE WELDMENT	101154-1	2	
27	PIN, CARBIDE WEAR	101155	2	
28	SCREW, M8X16-8.8 SOCKET HEAD	F81002-39	4	
29	BOLT, M6x45 WITHOUT HEAD	F81014-5	3	
30	WASHER 8.2 ZINC	F81054-4	4	
31	CHAIN, 06B-1, L=0,91m -96 LINKS AS80	500971	1	
32	LINK, 06B-1 AS80 W/MASTER	500972	1	

6 REPLACEMENT PARTS

Control Panel

6.7 Control Panel

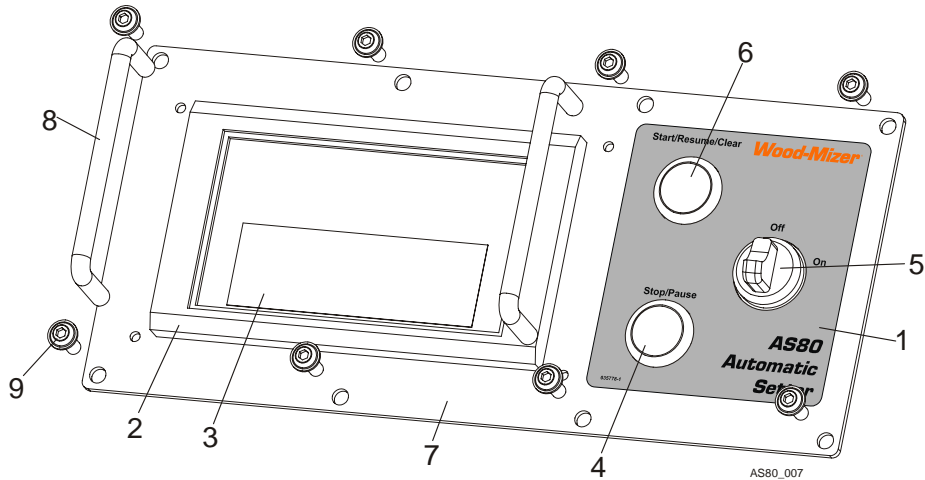

REF	DESCRIPTION (◆ Indicates Parts Available In Assemblies Only)	PART #	QTY.
	PANEL ASSEMBLY, AS80 CONTROL	500171	1
1	DECAL, AS80 CONTROL	035778-1	1
2	OPERATOR DISPLAY, OP-620	050124	1
3	LABEL SET, AS80 OPERATOR	054996	1
4	SWITCH HEAD, M22 RED EXTENDED	091364	1
5	SWITCH, 2 POS 1 NO CONTACT TOGGLE	091467	1
6	SWITCH HEAD, M22 GREEN GUARDED	094581	1
7	PANEL, FRONT CONTROL BOX	500161-1	1
8	HANDLE, DOOR	P08065	1
9	BOLT, M6x16 BN 11252 "BOSSARD"	F81001-24	8

6.8 Control Base Assembly

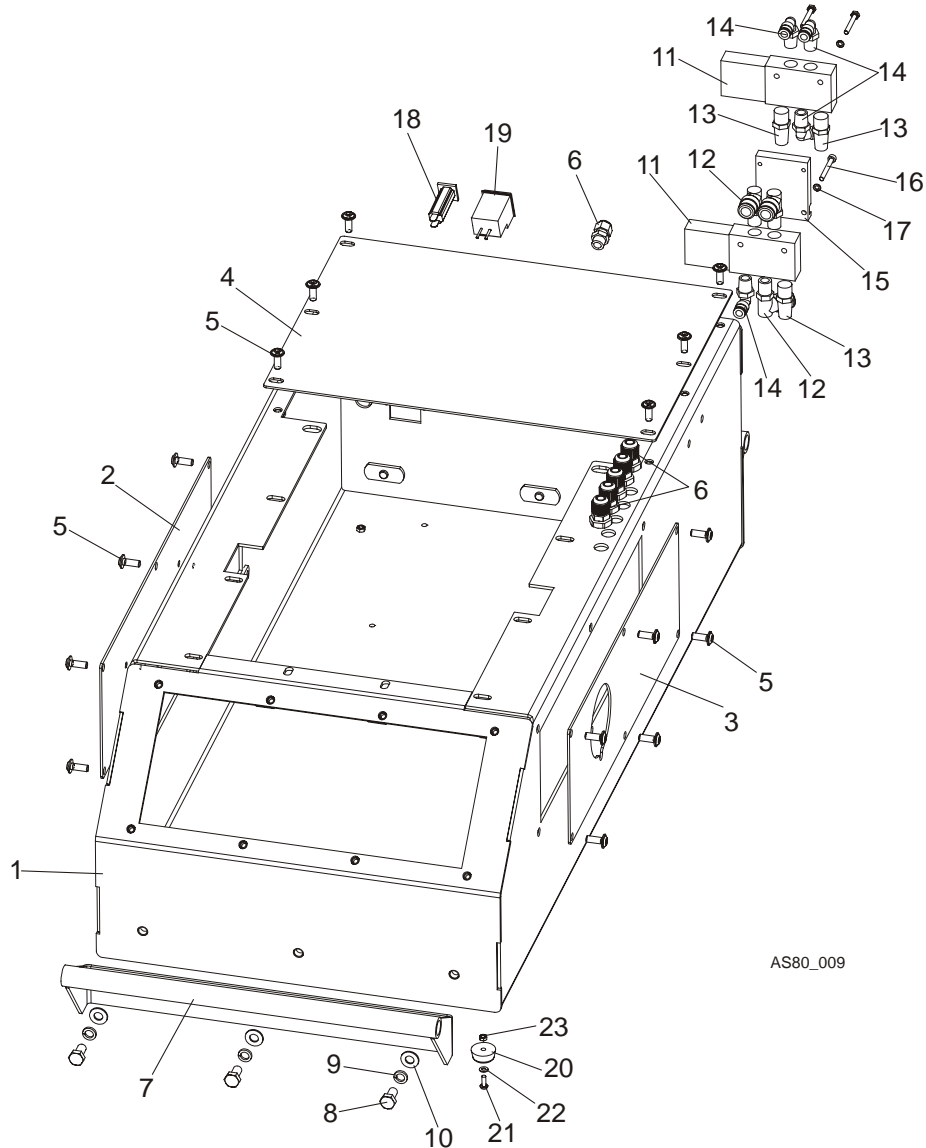

REF	DESCRIPTION (◆ Indicates Parts Available In Assemblies Only)	PART #	QTY.
1	BOX WELDMENT, AS80 CONTROL	101142-1	1
2	PANEL, CONTROL BOX SERVICE LEFT SIDE	101148-1	1
3	PANEL, CONTROL BOX SERVICE RIGHT SIDE	101149-1	1
4	PANEL, CONTROL BOX TOP SERVICE	500093-1	1
5	BOLT, M6x16 BN 11252 "BOSSARD"	F81001-24	18
6	GLAND, DP7/H CABLE	F81096-11	5
7	HANDLE, AS80 TRANSPORT COMPLETE (OPTION)	500815-1	2
8	BOLT, M8x16-8.8-B HH ZINC	F81002-20	6

6

REPLACEMENT PARTS*Control Base Assembly*

9	WASHER 8,2 ZINC	F81054-4	6	
10	WASHER, 8.4 FLAT ZINC	F81054-1	6	
11	VALVE, 4-WAY 24V AIR SOLENOID	035516	2	
12	FITTING, 1/4 IN NPT-3/8 IN 90 DEG AIR	P21521	3	
13	MUFFLER, 1/4 IN. NPT AIR	P20904	3	
14	FITTING, 1/4 NPT X 1/4 AIR 90 DEG.	P21519	1	
15	PLATE, AS80 VALVE ZINC	101147-1	1	
16	SCREW, M4X35-8.8 HEX SOCKET HEAD CAP ZINC	F81011-34	4	
17	WASHER, Z 4.1 SPLIT LOCK	F81051-1	4	
18	BREAKER, 3A PANEL MOUNT	E10466	1	
19	SOCKET, FYL06T1 POWER ENTRY	500454	1	
	FUSE, ZKT 2A TIME DELAY	500455	1	
20	FOOT, RUBBER	P06104	4	
21	SCREW, M4X12 5,8-B CROSS RECESSED PAN HEAD	F81011-43	4	
22	WASHER 4,3 FE/ZN5 PN-M/82005	F81051-2	4	
23	NUT, M4-B ZINC	F81029-2	4	

6.9 Blade Support Arms, Index Plate

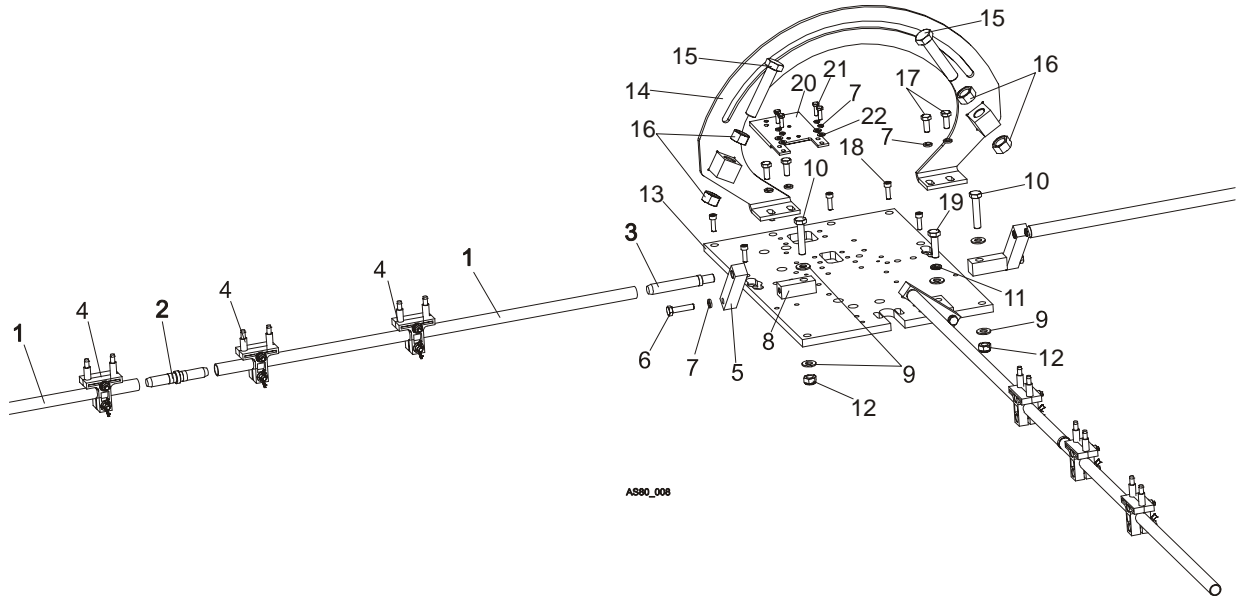

AS80_008

REF	DESCRIPTION (◆ Indicates Parts Available In Assemblies Only)	PART #	QTY.
	ARM ASSEMBLY, BLADE SUPPORT	500170	3
1	TUBE ASSY, BLADE SUPPORT	500095-1	2
2	LINK, BLADE ARM SUPPORT	500158	1
3	PIN, BLADE ARM SUPPORT	500159	1
4	GUIDE ASSEMBLY, BLADE SUPPORT	A30008	3
5	SUPPORT, BLADE ARM VERTICAL	500172-1	3
6	BOLT,M8X35-8.8 HEX HEAD FULL THREAD ZINC	F81002-13	3
7	WASHER 8,2 ZINC	F81054-4	11
8	BLOCK, AS80 BLADE SUPPORT ARM MOUNTING	500160-1	3
9	WASHER, 10.5 FLAT ZINC	F81055-1	6
10	BOLT, M10X50MM,HEX HEAD FULL THRD ZINC	F81003-4	2
11	WASHER, 10.2 SPLIT LOCK ZINC	F81055-2	1
12	NUT, M10-8-B HEX NYLON ZINC LOCK	F81033-1	3
13	PLATE, AS80 BASE	101150-1	1
14	PLATE WELDMENT, INDEX STOP	500090-1	1
15	BOLT, M16X80 8.8-B- FE/ZN5 HEX HEAD FULL	F81006-11	2
16	NUT, M16-5.8 HEX ZINC	F81036-1	4
17	BOLT,M8X20-5.8 HEX HEAD FULL THREAD ZINC	F81002-1	4
18	SCREW, M6 X 20 8.8 SOCKET HEAD	F81001-22	6
19	BOLT, M10X35-8.8 HEX HEAD FULL THREAD ZINC	F81003-17	1
20	PLATE EXTENSION, TOOTHSETTER	500092-1	1
21	BOLT, M8x25-8.8-B HEX HEAD FULL THREAD ZINC	F81002-5	4
22	WASHER, 8.4 FLAT ZINC	F81054-1	4

6 REPLACEMENT PARTS

Stand Option

6.10 Stand Option

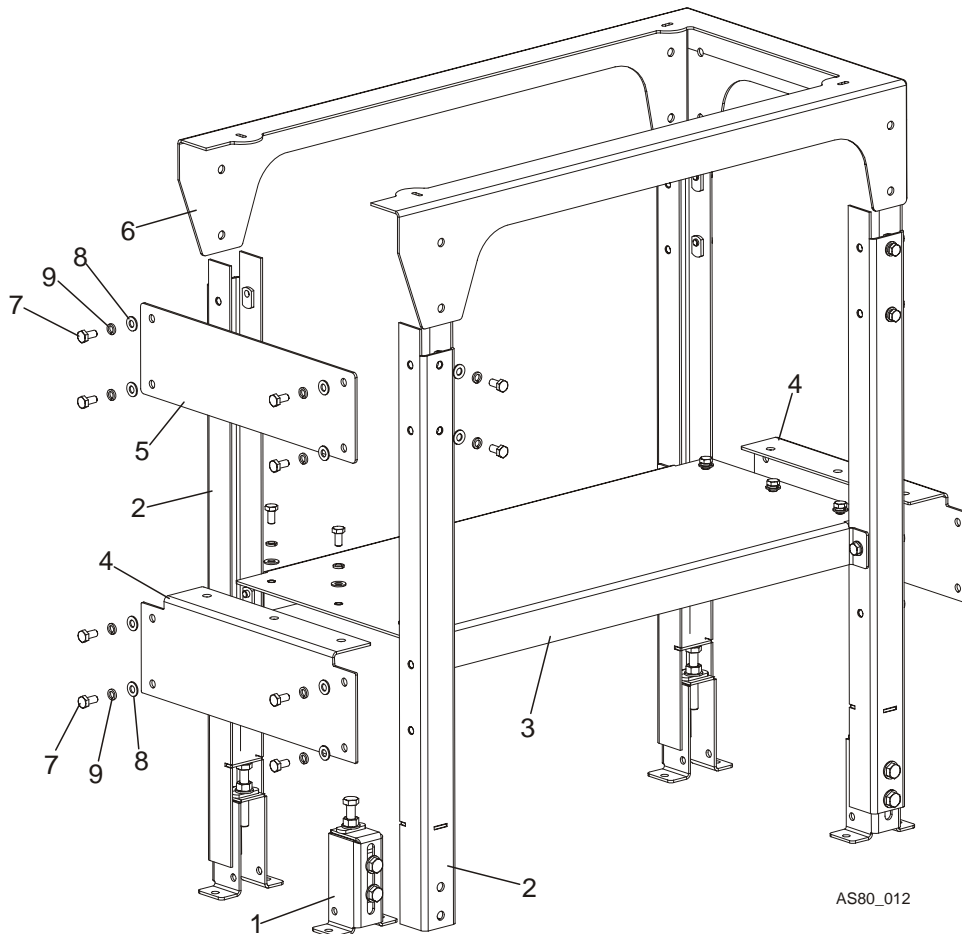

REF	DESCRIPTION (◆ Indicates Parts Available In Assemblies Only)	PART #	QTY.
	STAND, AS80 COMPLETE	501795	1
1	FOOT, OUTRIGGER COMPLETE	101237	4
2	BRACKET, STAND VERTICAL	501791-1	4
3	SHELF, AS80 STAND COMPLETE	501792-1	1
4	PLATE, LOWER STRENGHTEN	501793-1	2
5	PLATE, STRENGHTEN	501794-1	1
6	FRAME, AS80 STAND	501796-1	1
7	BOLT M8x16 -8.8-B-Fe/Zn5 PN-85/M-82105	F81002-20	34
8	WASHER, 8.4 FLAT ZINC	F81054-1	35
9	WASHER, 8.2 SPLIT LOCK ZINC	F81054-4	30

6.11 Decals, AS80

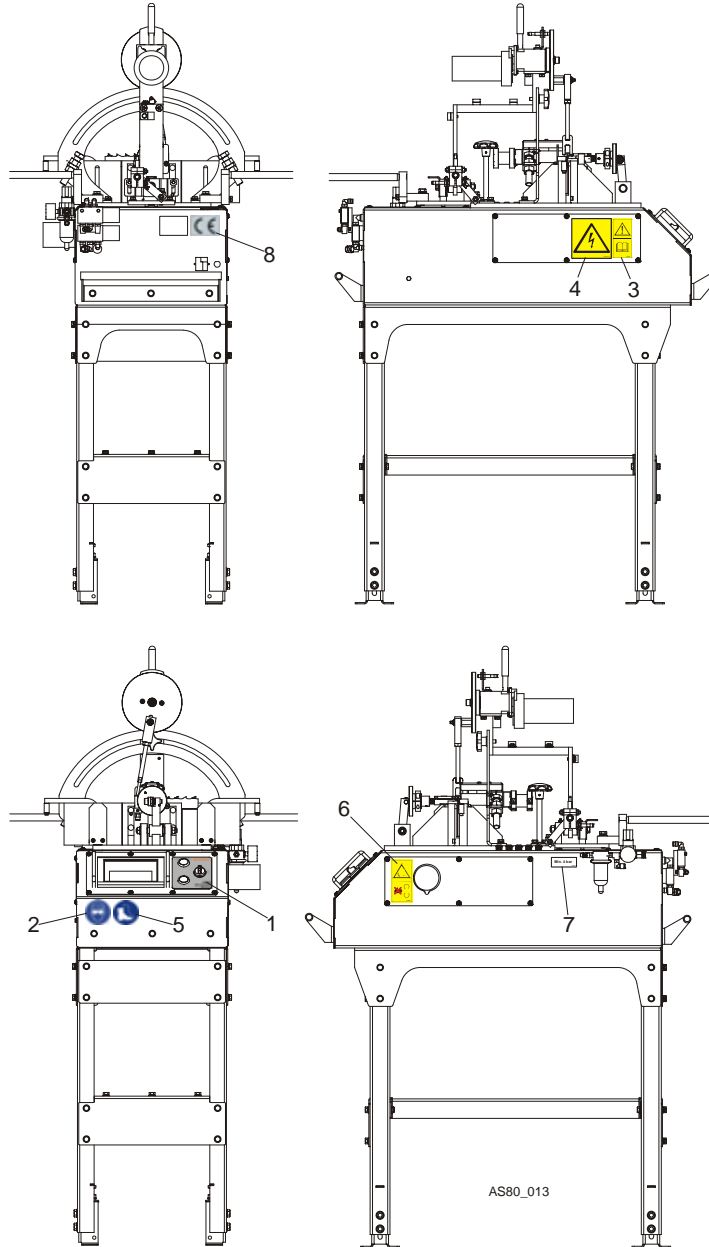

AS80_013

REF	DESCRIPTION (◆ Indicates Parts Available In Assemblies Only)	PART #	QTY.
	DECAL KIT, AS80	502948	1
1	DECAL, AS80 CONTROL	035778-1	1
2	DECAL, EYE WARNING SMALL	S12004G-1	1
3	DECAL, READ OPERATOR'S MANUAL	096317	1
4	DECAL, ELECTRIC POWER SIGN	S10364-P2	1
5	DECAL, USE SAFETY BOOTS SMALL (PICTOGRAM)	501465-1	1

6 REPLACEMENT PARTS

Decals, AS80

6	DECAL, GEAR TRAIN - KEEP SAFE DISTANCE	099540	1	
7	DECAL, MIN. 4 BAR AIR PRESSURE	502950	1	
8	DECAL, CE CERTIFICATION SMALL	P85070	1	

SECTION 7 ELECTRICAL INFORMATION

7.1 AS80 Electrical Diagram

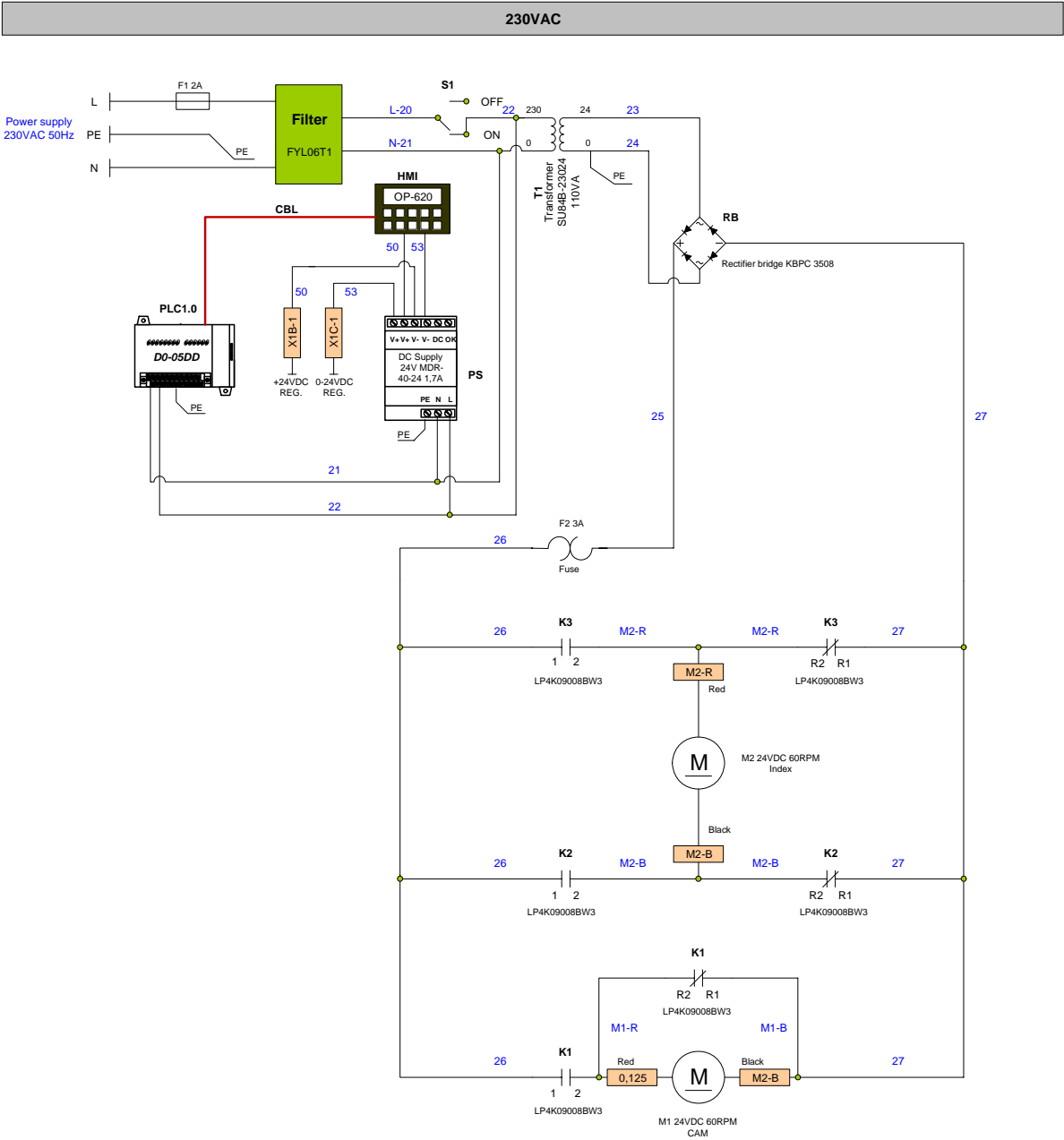

FIG. 7-1

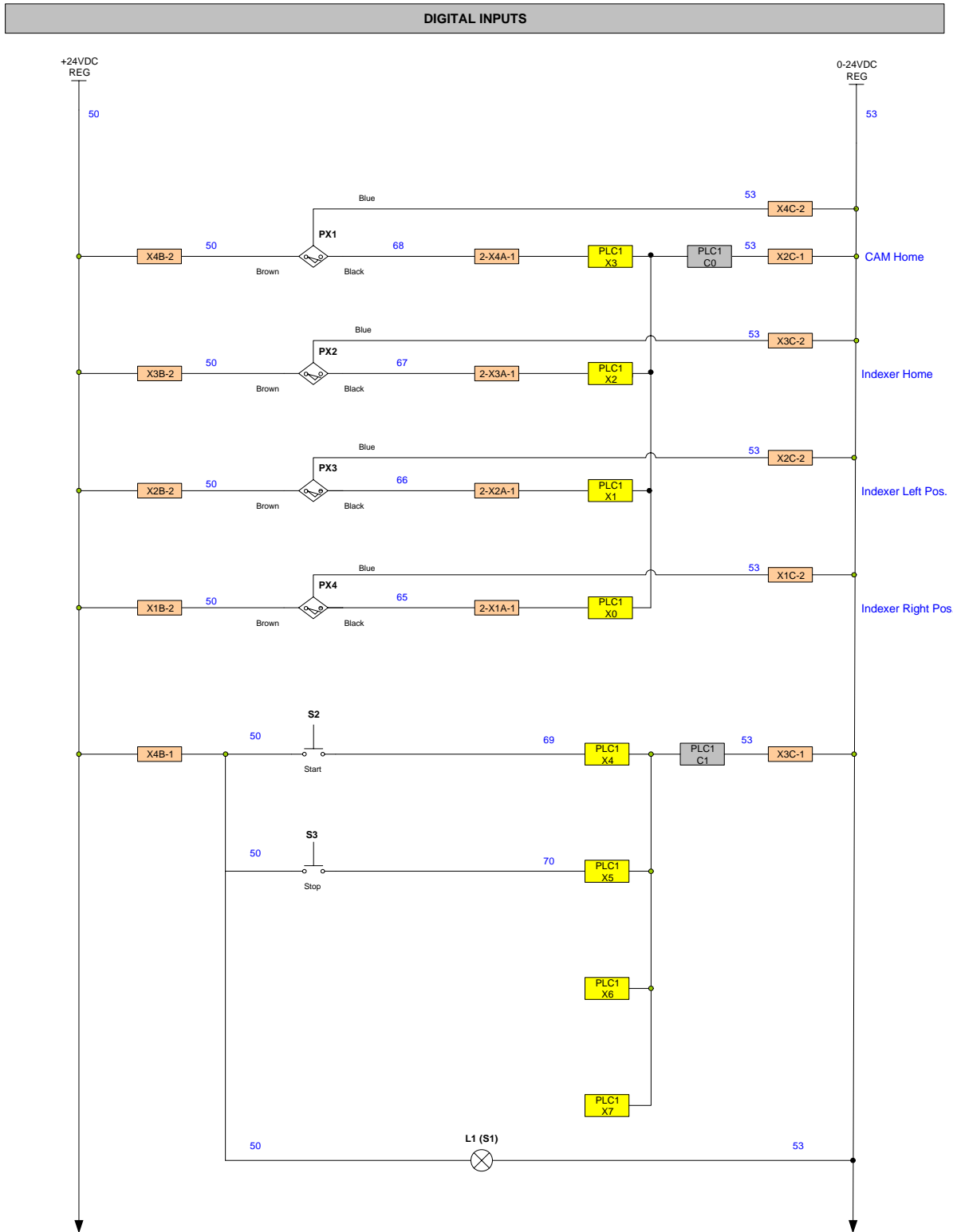

FIG. 7-2

DIGITAL OUTPUTS + ANALOG INPUT

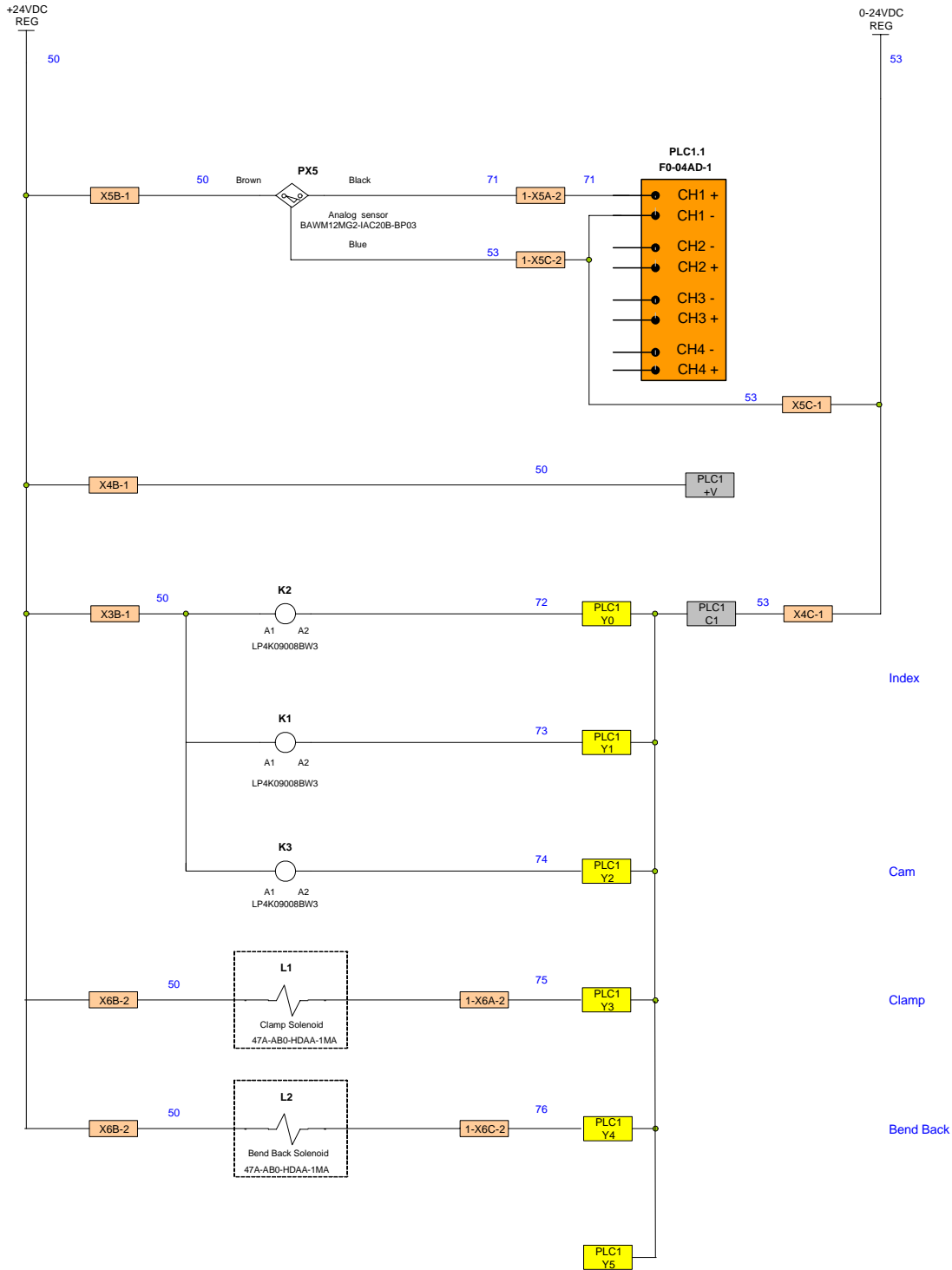

FIG. 7-3

7.2 Electrical Components

Component	Wood-Mizer Part No.	Description
Filter	500454	SOCKET, FYL06T1 POWER ENTRY
F1	500455	FUSE, ZKT 2A TIME DELAY
S1+L1	091467	SWITCH, 2 POS 1 NO CONTACT TOGGLE
T1	500453	TRANSFORMER SU84B-23024 110VA
RB	084318	RECTIFIER KBPC 3508 BRIDGE
HMI	050124	OPERATOR DISPLAY, OP-620
CBL	050125	DISPLAY CABLE, OP-620
PS	500452	POWER SUPPLY, 24V MDR-40-24 1,7A
PLC1.0	050065	ANOLOG MODULE PLC DL05, 8 DC IN/6 DC OUT 110/220V
F2	E10466	BREAKER, 3A PANEL MOUNT
K1, K2, K3	092478	CONTACTOR LP4 K09008 BW3
M1, M2	035659	MOTOR ASSY, 24V 60 RPM GEAR
PX1,PX2, PX3,PX4	500456	SENSOR BESM08MI-PSC20B-BV02 PROXIMITY
S2	094581	SWITCH HEAD, M22 GREEN GUARDED
S3	091364	SWITCH HEAD, M22 RED EXTENDED
PX5	500457	ANALOG SENSOR BAWM12MG2-IAC20B-BP03
PLC1.1	088296	ANOLOG MODULE DIRECT FO-04AD-1
L1, L2	035516	VALVE, 4-WAY 24V AIR SOLENOID

7.3 Electrical Component Layout

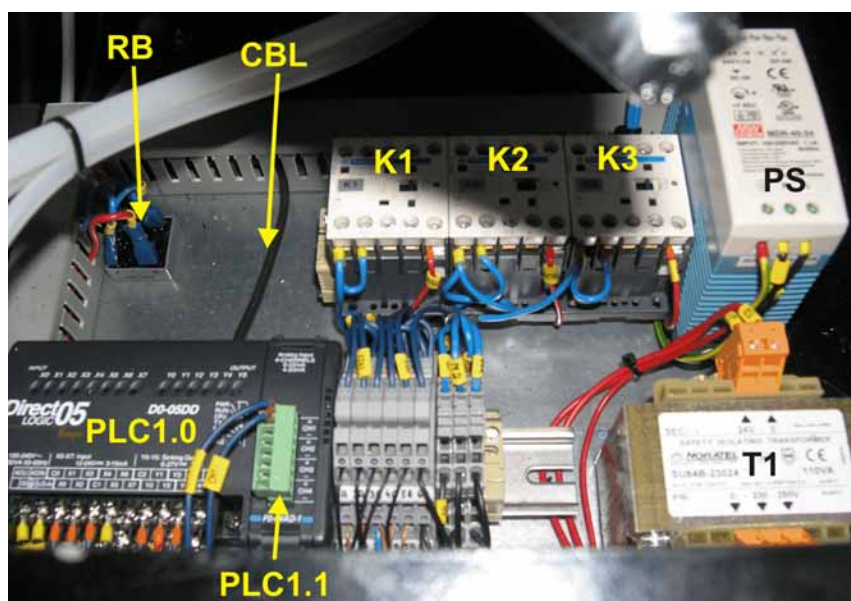

FIG. 7-4

EC declaration of conformity according to EC Machinery Directive 2006/42/EC

We herewith declare,

Wood-Mizer Industries sp. Z O.O.
114 Nagorna street, 62-600 Kolo; Poland.

That the following described machine in our delivered version complies with the appropriate basic safety and health requirements of the EC Machinery Directive 2006/42/EC based on its design and type, as brought into circulation by us. In case of alteration of the machine, not agreed by us, this declaration is no longer valid.

Designation of the machine:	Automatic Setter
TYPE:	AS80
No. of manufacturer:
Applicable EC Directives:	EC Machinery Directive 2006/42/EC EC Low-Voltage Directive 73/23/EEC EC Electromagnetic Compatibility Directive 2004/108/EC
Used harmonized standards:	EN 291-1, EN 292-2, EN 294, EN 563, EN 60204-1, EN 61000-6-3
Responsible for Technical Documentation:	Roman Frontczak / R&D Director
Date/Authorized Signature:	29. 12. 2009 
Title :	R&D Director