

Wood-Mizer®

Parts List

XC100 EH5S

rev. A1.00



Safety is our #1 concern! Read and understand all safety information and instructions before operating, setting up or maintaining this machine.

June 2014

Form #1031

Original Manual

Table of Contents

Section-Page

SECTION 1	REPLACEMENT PARTS	2-1
1.1	How To Use The Parts List	2-1
1.2	Sample Assembly	2-1
1.3	Extension Tables	2-2
1.4	Cutting Length Adjustment Assembly	2-3
1.5	Cutting Width Spacer	2-4
1.6	Sawdust Chute	2-5
1.7	Covers, Rollers & Pivot Plates	2-6
1.8	Pneumatic Hold-Down Unit	2-8
1.9	Blade Guard	2-10
1.10	Control Box	2-12
1.11	Air System Components	2-13
1.12	Cutting System Air Cylinder	2-14
1.13	Cutting System Drive	2-15
1.14	Belt Tensioner	2-17
1.15	Decals, XC100.....	2-18

SECTION 1 REPLACEMENT PARTS

1.1 How To Use The Parts List

- Use the index above to locate the assembly that contains the part you need.
- Go to the appropriate section and locate the part in the illustration.
- Use the number pointing to the part to locate the correct part number and description in the table.
- Parts shown indented under another part are included with that part.
- Parts marked with a diamond (◆) are only available in the assembly listed above the part.

See the sample table below. Sample Part #A01111 includes part F02222-2 and subassembly A03333. Subassembly A03333 includes part S04444-4 and subassembly K05555. The diamond (◆) indicates that S04444-4 is not available except in subassembly A03333. Subassembly K05555 includes parts M06666 and F07777-77. The diamond (◆) indicates M06666 is not available except in subassembly K05555.

1.2 Sample Assembly				
REF	DESCRIPTION (◆ Indicates Parts Available In Assemblies Only)	PART #	QTY.	
	Sample Assembly, Complete (Includes All Indented Parts Below)	A01111	1	
1	Sample Part	F02222-22	1	
	Sample Subassembly (Includes All Indented Parts Below)	A03333	1	
2	Sample Part (◆ Indicates Part Is Only Available With A03333)	S04444-4	1	◆
	Sample Subassembly (Includes All Indented Parts Below)	K05555	1	
3	Sample Part (◆ Indicates Part Is Only Available With K05555)	M06666	2	◆
4	Sample Part	F07777-77	1	

To order any part:

From Europe call our European Headquarters and Manufacturing Facility in Kolo, Poland at **+48-63-2626000**. From the continental U.S., call our toll-free Parts hotline at **1-800-525-8100**. Have your customer number, vehicle identification number, and part numbers ready when you call. From other international locations, contact the Wood-Mizer distributor in your area for parts.

1 Replacement Parts

Extension Tables

1.3 Extension Tables

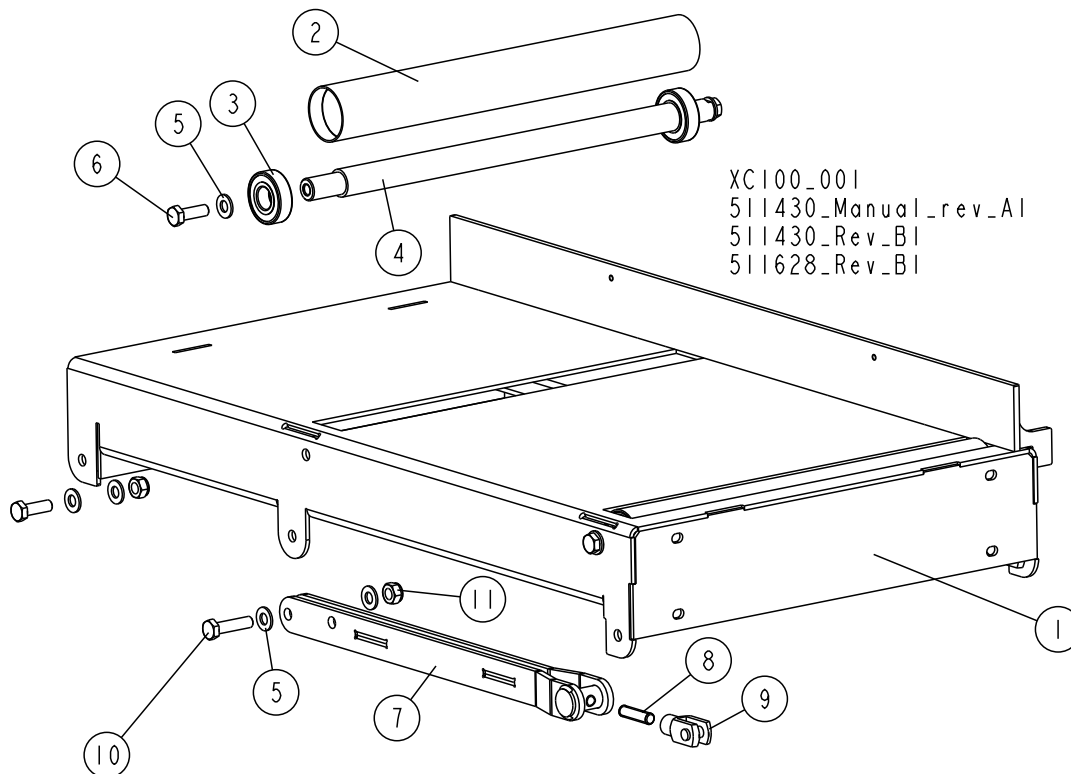

REF.	DESCRIPTION (◆ Indicates Parts Available In Assemblies Only)	PART #	QTY.
	TABLE, RIGHT EXTENSION - COMPLETE	511628	1
	TABLE, LEFT EXTENSION - COMPLETE	511629	1
5	TABLE WELDMENT, RIGHT EXTENSION	511432-1	1
	TABLE WELDMENT, LEFT EXTENSION	511442-1	1
	ROLLER, EXTENSION TABLE - COMPLETE	511626-1	2
6	TUBE, TABLE ROLLER	511434	1
7	BEARING, 6204 2RS CX. ROLLING	088447	2
8	SHAFT, TABLE ROLLER	511627	1
9	WASHER, 10.5 FLAT ZINC	F81055-1	12
10	BOLT, M10X30 5.8 HEX HEAD FULL THREAD ZINC	F81003-2	6
	ARM, XC100 TABLE SUPPORT - COMPLETE	513285	2
11	ARM, TABLE SUPPORT	512579-1	1
12	STUD, M10X1.25-40 THREADED	513164	1
13	FORK, 1320.32.13/1F (M10X1.25) W/CLIP	513284	1
14	BOLT, M10X40-8.8 HEX HEAD FULL THREAD ZINC	F81003-16	2
15	NUT, M10-8-B HEX NYLON ZINC LOCK	F81033-1	4

1.4 Cutting Length Adjustment Assembly

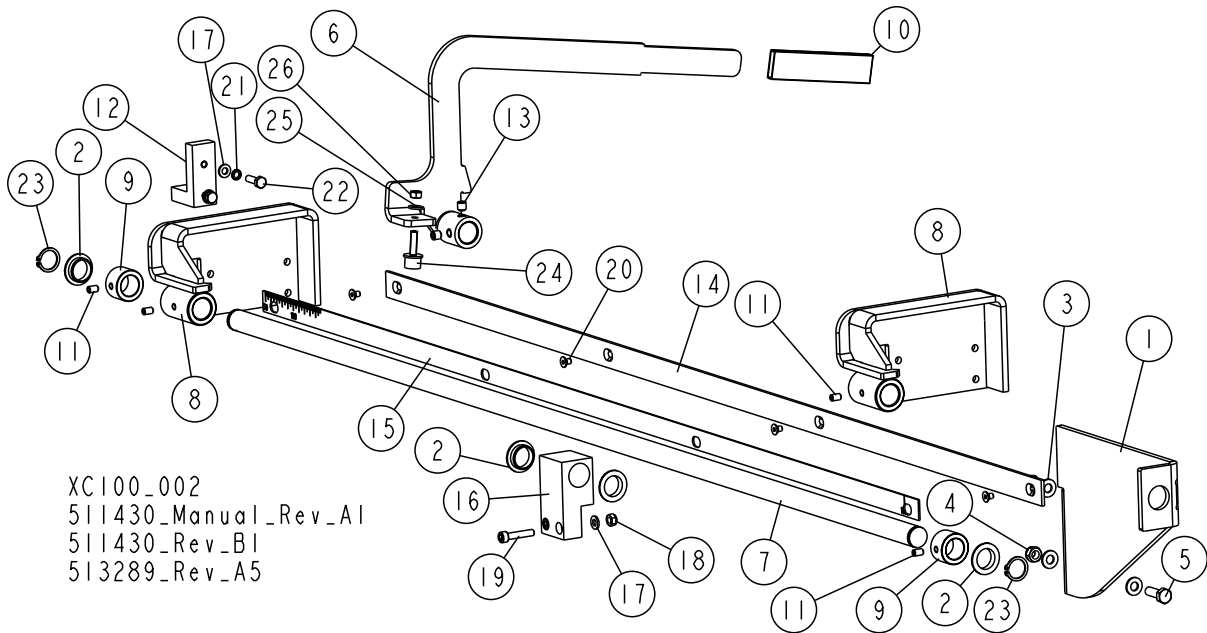

REF.	DESCRIPTION (◆ Indicates Parts Available In Assemblies Only)	PART #	QTY.
	CUTTING LENGTH ADJUSTMENT SYSTEM (1.2 M)	513289	1
1	BRACKET, ROD MOUNTING	512907-1	1
2	BEARING, GFM-2023-07 FLANGED	513272	4
3	WASHER, 8.4 FLAT ZINC	F81054-1	4
4	NUT, M8 8 HEX NYLON ZINC LOCK	F81032-2	2
5	BOLT, M8X25-8.8-B HEX HEAD FULL THREAD ZINC	F81002-5	2
6	ARM, LIFTING	513293-1	1
7	ROD, LENGTH ADJUSTMENT SYSTEM - LONG	512602	1
8	STOP, COMPLETE LEFT	512605-1	2
9	BUSHING	512597-1	2
10	CAP, REWA 91626 LIFTING ARM	086875	1
11	SCREW, M6X10-45H HEX SOCKET SET FLAT POINT ZINC	F81001-26	4
12	ANGLE, SPACER	513294	1
13	SCREW, M8X8-33H GEOMET HEX SOCKET SET FLAT POINT	F81014-1	2
14	BAR, XC100 SCALE	513297	1
15	DECAL, XC100 METRIC SCALE	513296	1
16	BLOCK, MIDDLE ROD SUPPORT	513621-1	1
17	WASHER, 6.4 FLAT ZINC	F81053-1	4
18	NUT, M6-8-B HEX NYLON ZINC LOCK	F81031-2	2
19	SCREW, M6X30-8.8 HEX SOCKET HEAD CAP ZINC	F81001-42	2
20	SCREW, M5X8-10.9 FLAT SOCKET HEAD CAP ZINC	F81000-46	4
21	WASHER, Z 6.1 SPLIT LOCK ZINC	F81053-3	2
22	BOLT, M6X20 8.8 HEX HEAD FULL THREAD ZINC	F81001-2	2
23	RING, Z 20 OUTSIDE RETAINING	F81090-27	2
	BUMPER, A/022 COMPLETE	088376	1

1 Replacement Parts

Cutting Width Spacer

REF.	DESCRIPTION (◆ Indicates Parts Available In Assemblies Only)	PART #	QTY.
24	BUMPER, A/022 METAL & RUBBER	088375	1
25	WASHER, 6.4 FLAT ZINC	F81053-1	1
26	NUT, M6 8 HEX ZINC	F81031-1	1

1.5 Cutting Width Spacer

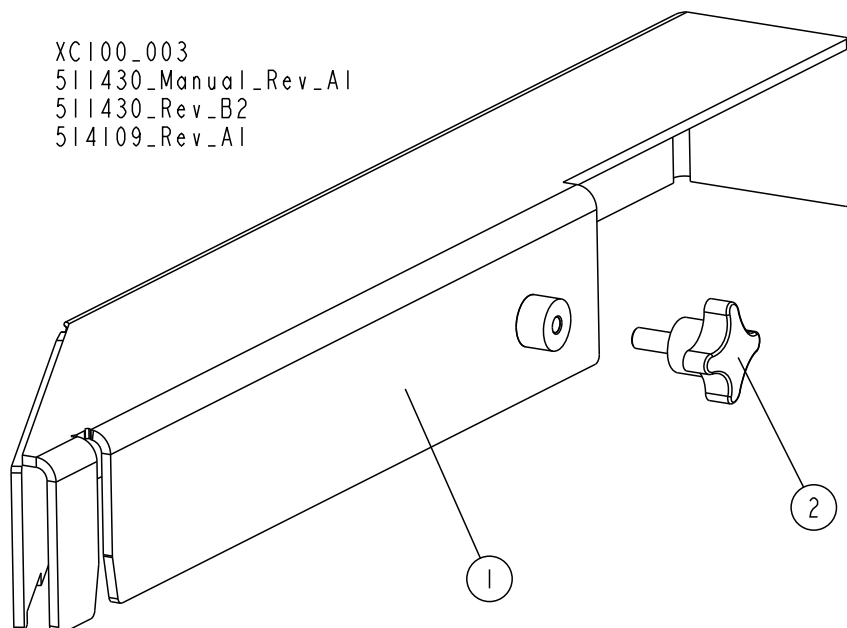

REF.	DESCRIPTION (◆ Indicates Parts Available In Assemblies Only)	PART #	QTY.
	SPACER, CUTTING WIDTH - COMPLETE	514109	1
1	SPACER, CUTTING WIDTH	514108-1	1
2	KNOB, 40/M8X20 (462053 MOSS) STAR	500973	1

1.6 Sawdust Chute

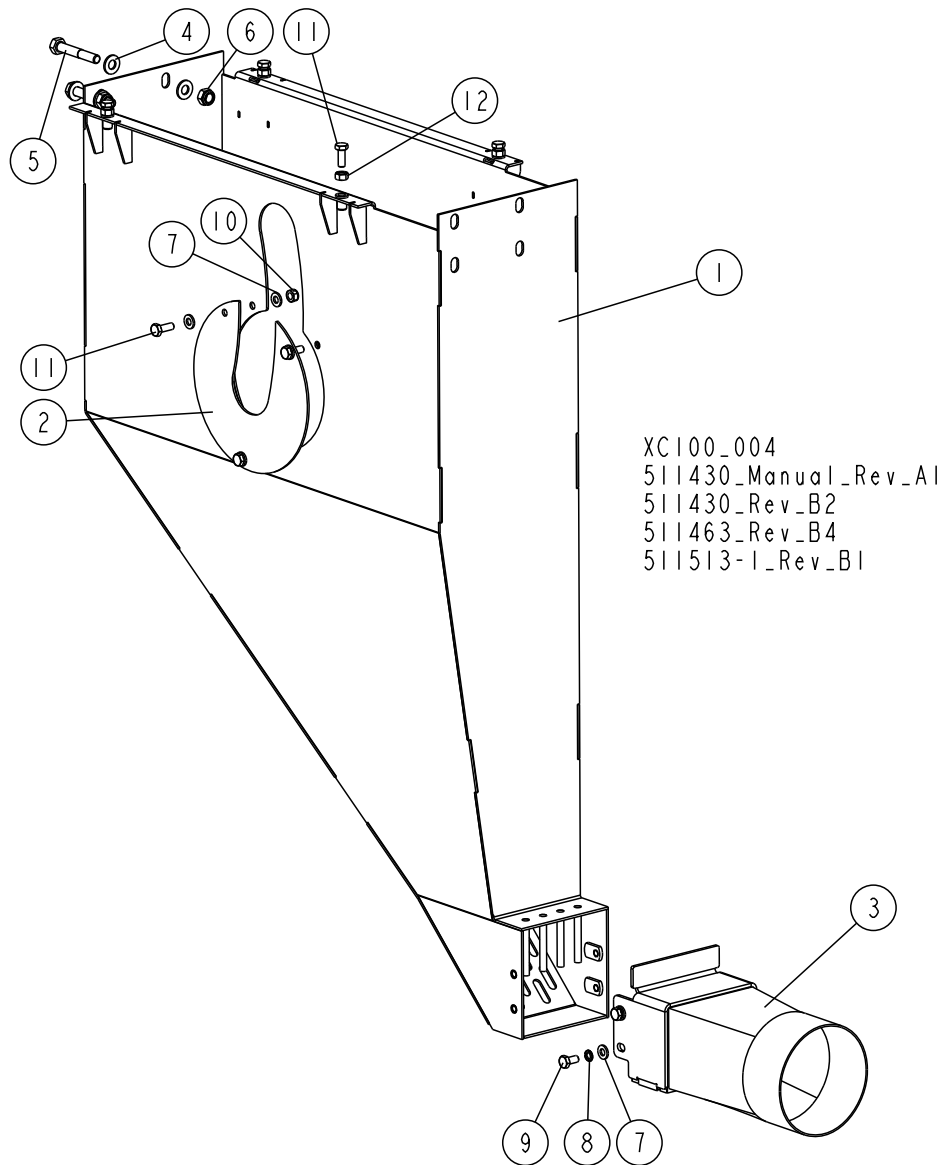

REF.	DESCRIPTION (◆ Indicates Parts Available In Assemblies Only)	PART #	QTY.	
1	CHUTE WELDMENT, SAWDUST	511513-1	1	
2	PLATE, COVER	511520-1	1	
3	TUBE WELDMENT, SAWDUST CHUTE END	512773-1	1	
4	WASHER, 8.4 FLAT ZINC	F81054-1	4	
5	BOLT, M8X50 8.8 HEX HEAD ZINC	F81002-10	2	
6	NUT, M8 8 HEX NYLON ZINC LOCK	F81032-2	2	
7	WASHER, 6.4 FLAT ZINC	F81053-1	10	
8	WASHER, Z 6.1 SPLIT LOCK ZINC	F81053-3	4	
9	BOLT, M6X12 8.8 HEX HEAD FULL THREAD ZINC	F81001-7	4	
10	NUT, M6-8-B HEX NYLON ZINC LOCK	F81031-2	3	
11	BOLT, M6X16-8.8 HEX HEAD FULL THREAD ZINC	F81001-15	7	
12	NUT, M6 8 HEX ZINC	F81031-1	4	

1 Replacement Parts

Covers, Rollers & Pivot Plates

1.7 Covers, Rollers & Pivot Plates

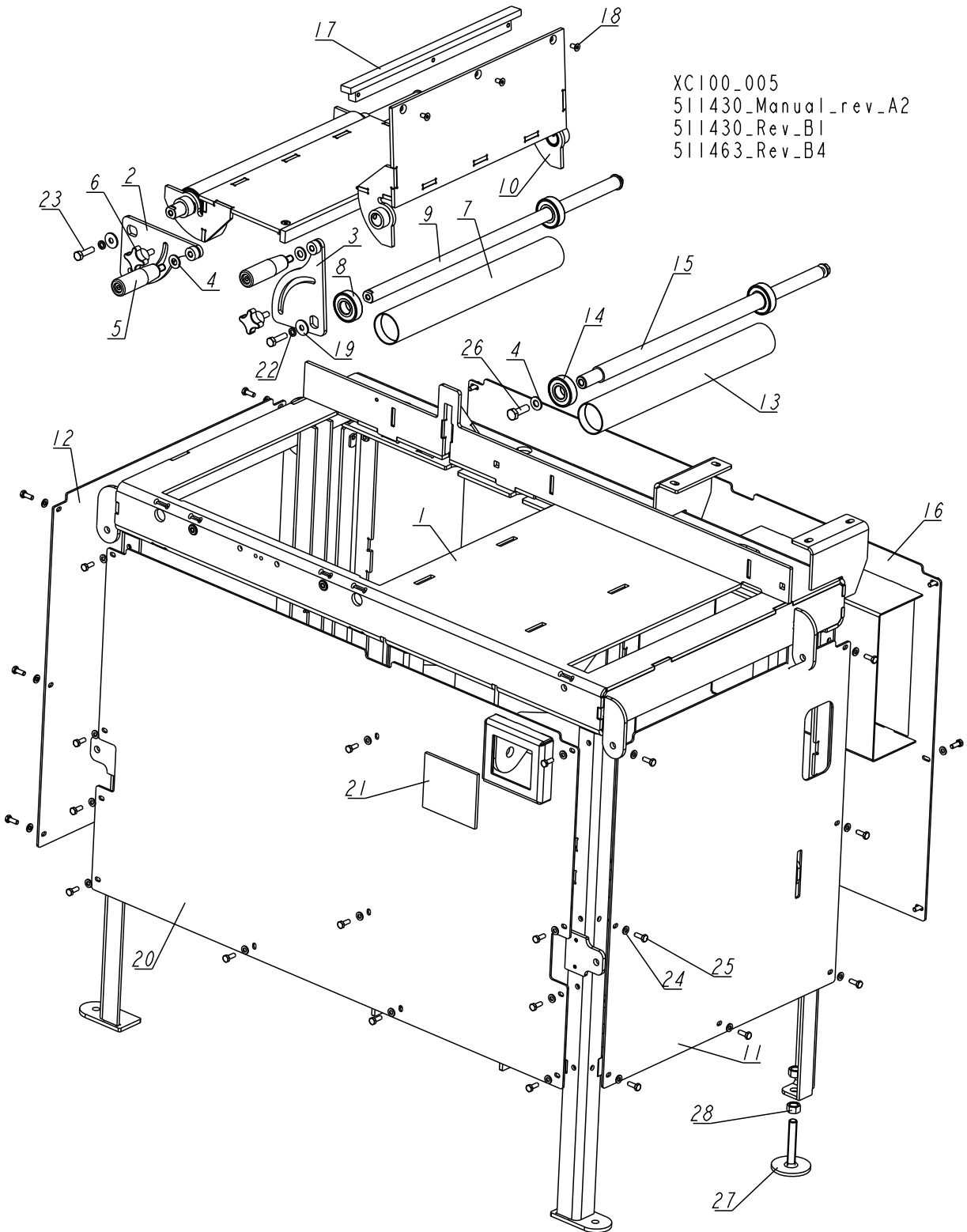

XC100_005
 511430_Manual_rev_A2
 511430_Rev_B1
 511463_Rev_B4

REF.	DESCRIPTION (◆ Indicates Parts Available In Assemblies Only)	PART #	QTY.
1	FRAME WELDMENT, CROSS-CUT SAWING MACHINE	511438-1	1

Replacement Parts

Covers, Rollers & Pivot Plates

1

REF.	DESCRIPTION (◆ Indicates Parts Available In Assemblies Only)	PART #	QTY.	
2	HANDLE, PIVOT PLATE LEFT	511465-1	1	
3	HANDLE, PIVOT PLATE RIGHT	511466-1	1	
4	WASHER, 10.5 FLAT ZINC	F81055-1	4	
5	KNOB, L=85 M10, RO11-M10 PLASTIC HANDLE	086338	2	
6	KNOB, 40/M8X20 (462053 MOSS) STAR	500973	2	
	ROLLER - COMPLETE	511468-1	2	
7	ROLLER, MIDDLE TABLE	511459	1	
8	BEARING, 6204 2RS CX ROLLING	088447	2	
9	SHAFT, MIDDLE TABLE ROLLER	511467	2	
10	PLATE, PIVOT	511458-1	2	
11	COVER, SIDE	511559-1	1	
12	COVER, SIDE	511630-1	1	
	ROLLER, MIDDLE TABLE - COMPLETE	511624-1	1	
13	TUBE, ROLLER	511434	1	
14	BEARING, 6204 2RS CX ROLLING	088447	2	
15	SHAFT, TABLE ROLLER - LONG	511623	1	
16	COVER WELDMENT, REAR	511765-1	1	
17	BAR, PIVOT PLATE	512288	2	
18	SCREW, M6X12-10.9 FE/ZN5 DIN7991 FLAT SOCKET HEAD CAP	F81001-54	6	
19	WASHER, ISO 7093-1-8-200 HV-A2E	F81054-11	4	
	COVER, COMPLETE FRONT	512769	1	
20	COVER, FRONT	512770-1	1	
21	WINDOW, INSPECTION	512742	1	
22	WASHER, 8.2 SPLIT LOCK ZINC	F81054-4	4	
23	BOLT, M8X30-5.8-B HEX HEAD FULL THREAD ZINC	F81002-2	4	
24	WASHER, 6.4 FLAT ZINC	F81053-1	37	
25	BOLT, M6X16-8.8 HEX HEAD FULL THREAD ZINC	F81001-15	36	
26	BOLT, M10X30 5.8 HEX HEAD FULL THREAD ZINC	F81003-2	2	
27	FOOT, XC100 ADJUSTABLE	513628-1	2	
28	NUT, M12-8 HEX ZINC	F81034-1	4	

1 Replacement Parts

Pneumatic Hold-Down Unit

1.8 Pneumatic Hold-Down Unit

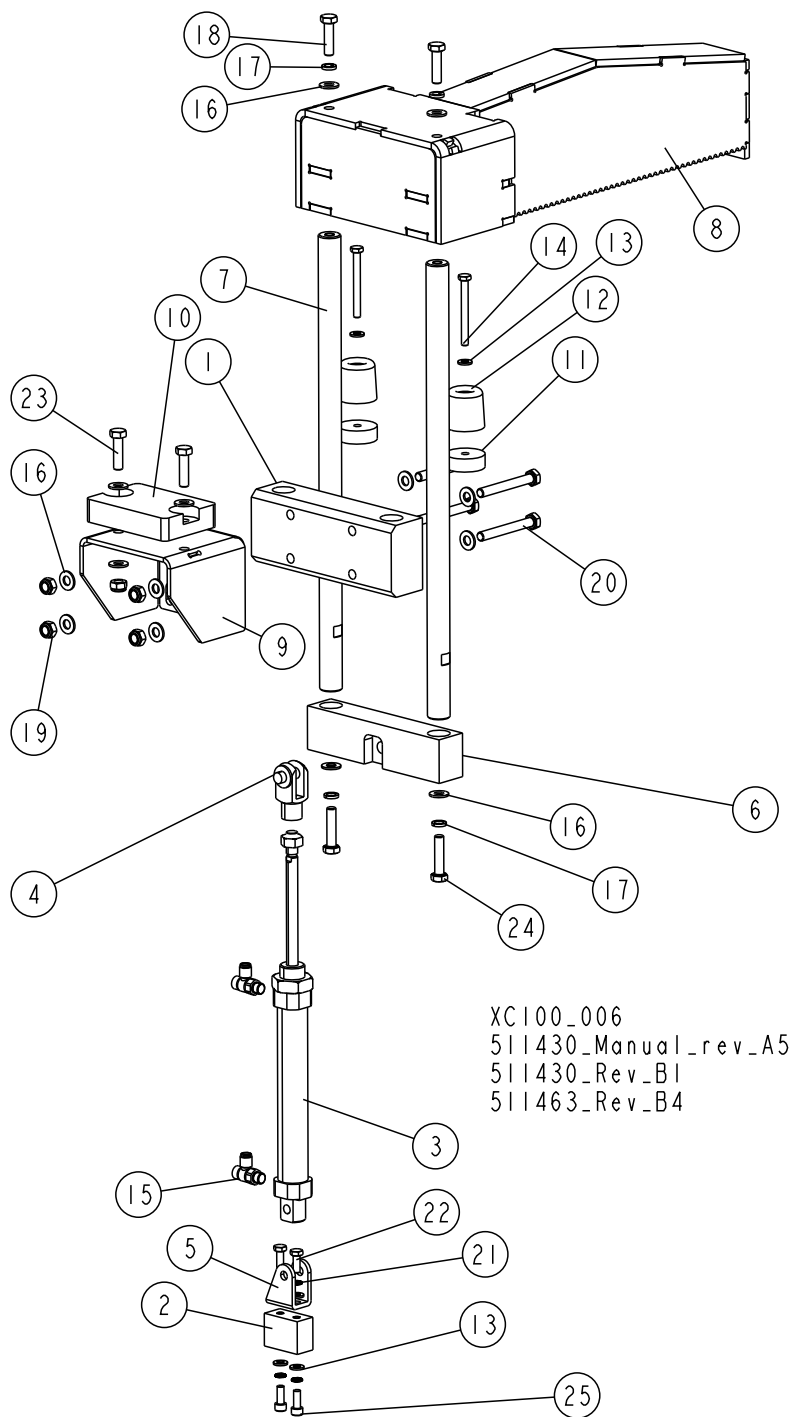

REF.	DESCRIPTION (◆ Indicates Parts Available In Assemblies Only)	PART #	QTY.
1	BLOCK, GUIDE	511756	1
2	BLOCK, CYLINDER MOUNTING	511736-1	1
	CYLINDER ASSEMBLY, XC100 AIR	511607	1
3	CYLINDER, ISO CD85N25-120-B AIR	513456	1

REF.	DESCRIPTION (◆ Indicates Parts Available In Assemblies Only)	PART #	QTY.	
4	CLEVIS, GKM10-20 PISTON ROD	513457	1	
5	BRACKET, C85C25 CLEVIS	513458	1	
6	BLOCK, AIR CYLINDER MOUNT	514105-1	1	
7	BAR, GUIDE	514106-1	2	
8	JAW WELDMENT, HOLD-DOWN	511745-1	1	
9	BRACKET, RUBBER BUMPER MOUNT	512588-1	1	
10	BUMPER, GRENE 70 3201 0010 RUBBER	094969	1	
11	WASHER, 35/6.5-12 SPACER	513453	2	
12	BUMPER	087825	2	
13	WASHER, 6.4 FLAT ZINC	F81053-1	6	
14	BOLT, M6X60-8.8 HEX HEAD FULL THREAD ZINC	F81001-9	2	
15	VALVE, AS2201F-01-06SA FLOW CONTROL	513455	2	
16	WASHER, 8.4 FLAT ZINC	F81054-1	16	
17	WASHER, 8.2 SPLIT LOCK ZINC	F81054-4	4	
18	BOLT, M8X30 8.8 HEX HEAD FULL THREAD ZINC	F81002-7	2	
19	NUT, M8 8 HEX NYLON ZINC LOCK	F81032-2	6	
20	BOLT, M8X65 8.8 HEX HEAD FULL THREAD ZINC	F81002-9	4	
21	WASHER, Z 6.1 SPLIT LOCK ZINC	F81053-3	4	
22	BOLT, M6X16-8.8 HEX HEAD FULL THREAD ZINC	F81001-15	2	
23	BOLT, M8X30-5.8-B HEX HEAD FULL THREAD ZINC	F81002-2	2	
24	BOLT, M8X35-8.8 HEX HEAD FULL THREAD ZINC	F81002-13	2	
25	SCREW, M6X16 8.8 HEX SOCKET HEAD CAP ZINC	F81001-21	2	

1 Replacement Parts

Blade Guard

1.9 Blade Guard

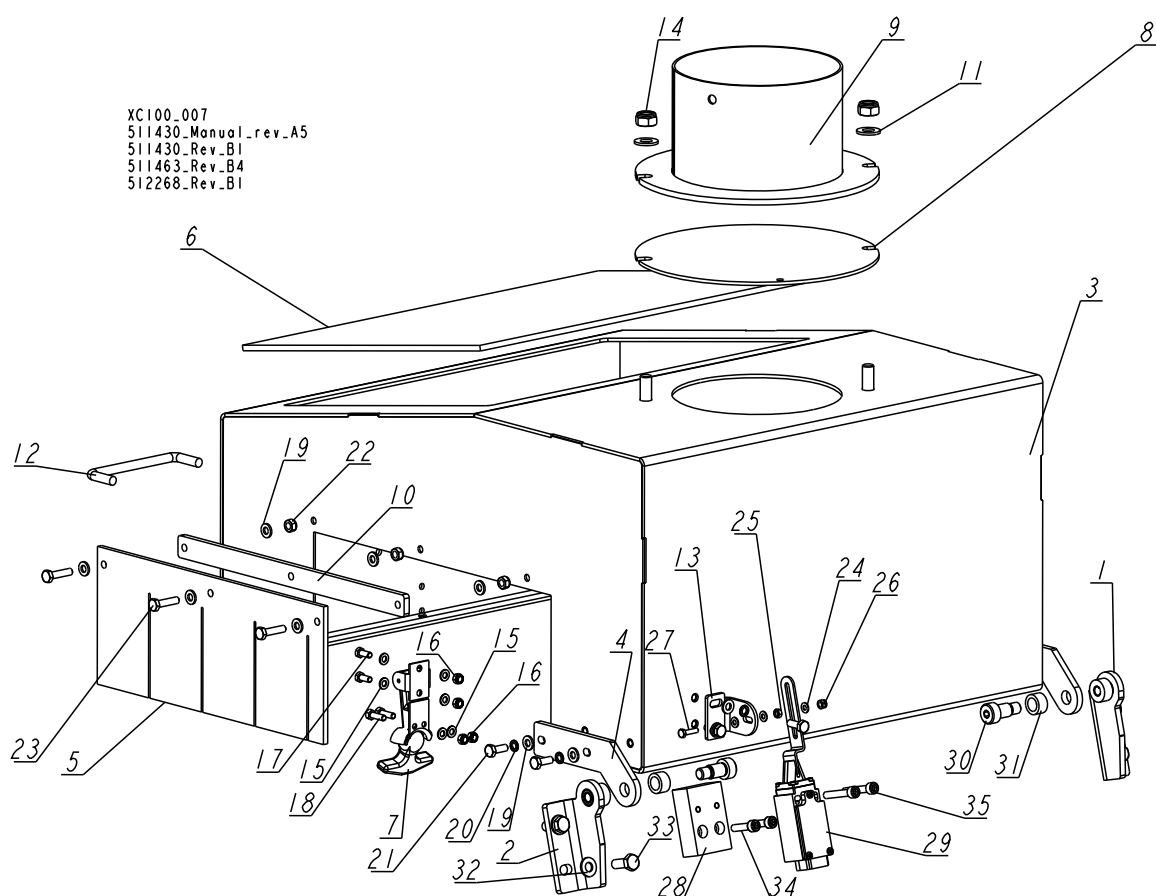

REF.	DESCRIPTION (◆ Indicates Parts Available In Assemblies Only)	PART #	QTY.
1	BRACKET, BLADE GUARD MOUNTING - LEFT	512280-1	1
2	BRACKET, BLADE GUARD MOUNTING - RIGHT	512282-1	1
	GUARD, XC100 BLADE	512268	1
3	GUARD WELDMENT, XC100 BLADE	512265-1	1
4	PLATE, BLADE GUARD MOUNTING	512278-1	2
5	CURTAIN, XC100 BLADE GUARD	512269	2
6	WINDOW, XC100 INSPECTION	512270	1
7	LATCH, FLEXIBLE DRAW	014829	1
8	PLATE, COVER	512778-1	1
9	PIPE WELDMENT, SAWDUST EXTRACTOR CONNECTOR	095412-1	1
10	BAR, BLADE GUARD	512283-1	2
11	WASHER, 10.5 FLAT ZINC	F81055-1	2
12	HANDLE, 4"	P08065	1
13	PLATE, SAFETY SWITCH ACTIVATOR	512521-1	1
14	NUT, M10-8-B HEX NYLON ZINC LOCK	F81033-1	2
15	WASHER, 5.3 FLAT ZINC	F81052-1	6
16	NUT, M5-8-FE/ZN5 DIN985	F81030-2	4
17	BOLT, M5X12 5.8 HEX HEAD FULL THREAD ZINC	F81000-5	2

REF.	DESCRIPTION (◆ Indicates Parts Available In Assemblies Only)	PART #	QTY.	
18	BOLT, M5X16 8.8 HEX HEAD FULL THREAD ZINC	F81000-20	2	
19	WASHER, 6.4 FLAT ZINC	F81053-1	18	
20	WASHER, Z 6.1 SPLIT LOCK ZINC	F81053-3	6	
21	BOLT, M6X16-8.8 HEX HEAD FULL THREAD ZINC	F81001-15	6	
22	NUT, M6-8-B HEX NYLON ZINC LOCK	F81031-2	6	
23	BOLT, M6X25 5.8 HEX HEAD FULL THREAD ZINC	F81001-3	6	
24	WASHER, 4.3 FLAT ZINC	F81051-2	3	
25	NUT, M5 8 HEX ZINC	F81029-2	1	
26	NUT, M4-8 HEX NYLON ZINC LOCK	F81029-1	1	
27	BOLT, M4X16-8.8 HEX HEAD FULL THREAD ZINC	F81011-6	1	
28	BLOCK, SAFETY SWITCH MOUNT	512520	1	
29	SWITCH, GSCA 01S1 SAFETY	088836	1	
30	BOLT, 12/M10X16 12.9 BOSSARD SHOULDER	F81003-64	2	
31	WASHER, 12/18-10 SPACER	513275	2	
32	WASHER, 8.4 FLAT ZINC	F81054-1	4	
33	BOLT, M8X20 8.8 HEX HEAD FULL THREAD ZINC	F81002-4	4	
34	SCREW, M6X25-8.8 HEX SOCKET HEAD CAP ZINC	F81001-41	2	
35	SCREW, M6X35 8.8 HEX SOCKET HEAD CAP ZINC	F81001-23	2	

1 Replacement Parts

Control Box

1.10 Control Box

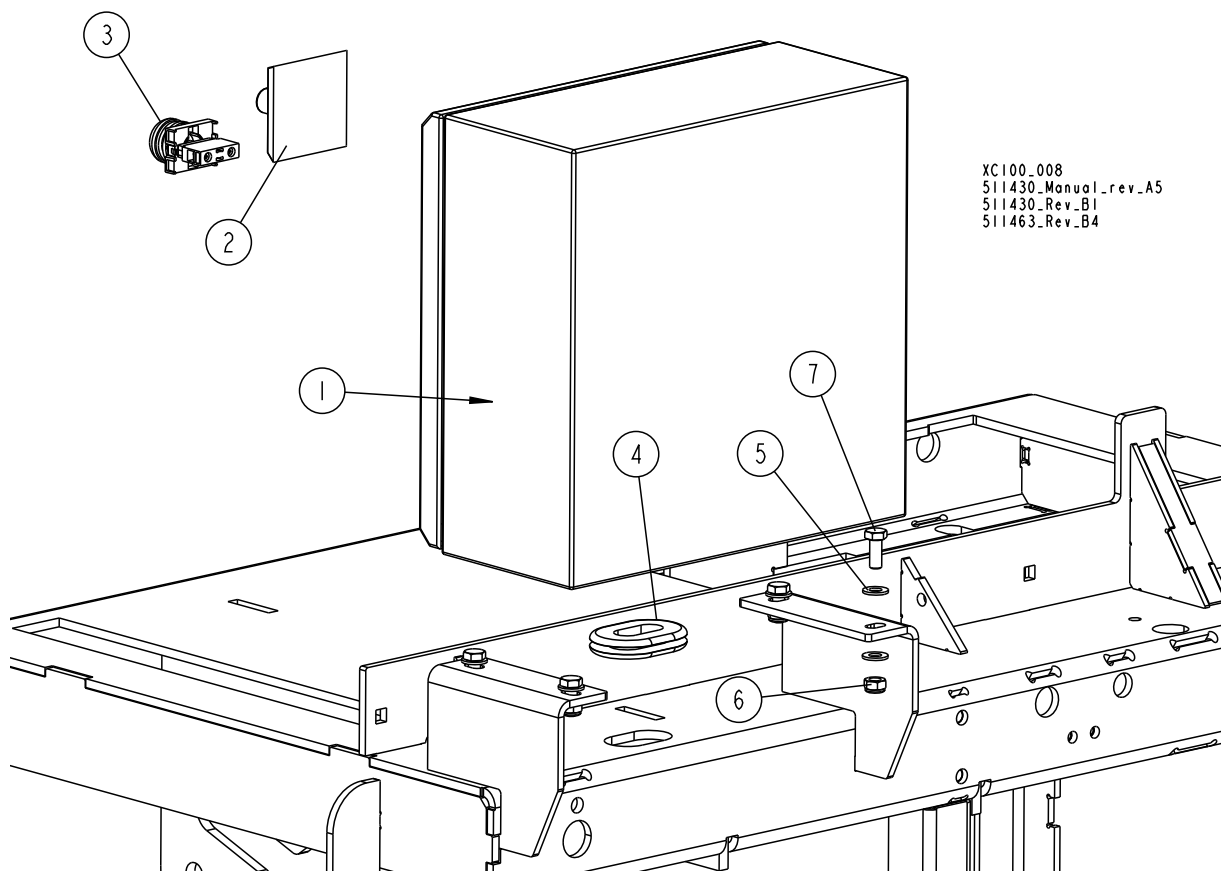

REF.	DESCRIPTION (◆ Indicates Parts Available In Assemblies Only)	PART #	QTY.
36	BOX, XC100 - 400V CONTROL	511564	1
1	BOX WELDMENT, S83002/300X300X150	092627	1
2	HANDLE, ABB SELECTOR SWITCH	088265-1	1
3	LIGHT, M22 LED 24V BLUE CONTROL	090448	1
4	GROMMET, 38X26X4MM RUBBER	085613	1
5	WASHER, 8.4 FLAT ZINC	F81054-1	8
6	NUT, M8 8 HEX NYLON ZINC LOCK	F81032-2	4
7	BOLT, M8X20 8.8 HEX HEAD FULL THREAD ZINC	F81002-4	4

1.11 Air System Components

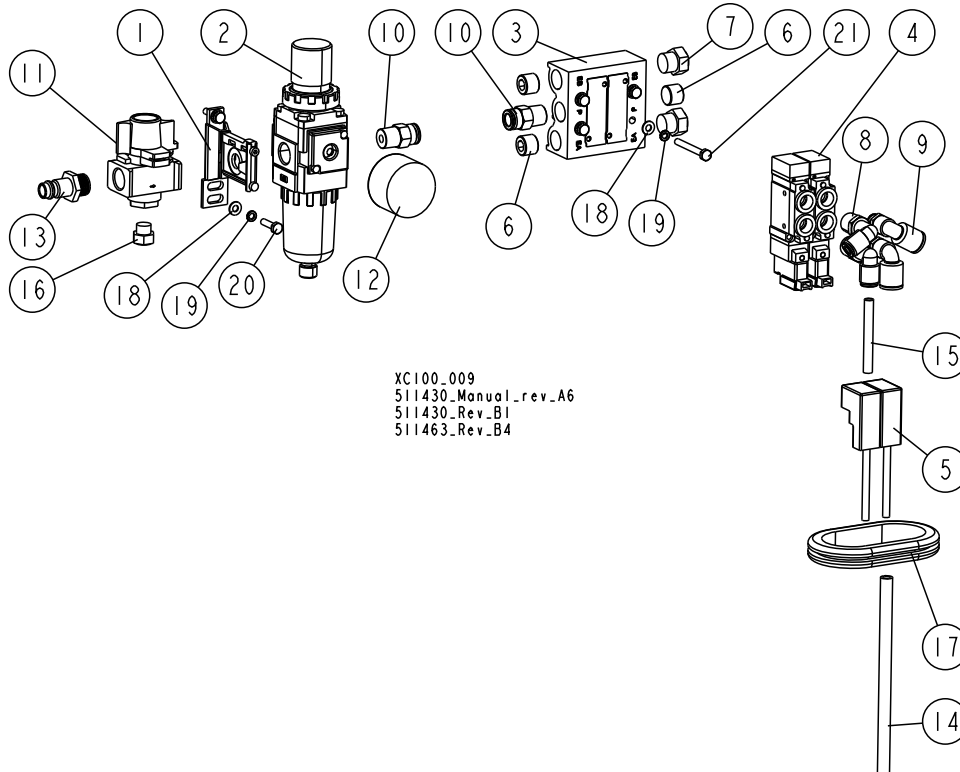

XC100-009
511430_Manual_rev_A6
511430_Rev_B1
511463_Rev_B4

REF.	DESCRIPTION (◆ Indicates Parts Available In Assemblies Only)	PART #	QTY.
1	SPACER, Y200T W/BRACKET	513454	1
2	REGULATOR, AW20-F02H-X64 FILTER	510674	1
3	MANIFOLD, SS5Y5-20-02-00F-Q	510933	1
4	VALVE, 5/2 - SY5120-5YO-01F-Q SOLENOID	510071	2
5	CONNECTOR, DIN - K41	513459	2
6	PLUG, 1/4" - TB00024	510170	3
7	SILENCER, R1/4" - AN-SM-02	513460	2
8	FITTING, KQ2L06-OIS (6 MM; R1/8) MALE ELBOW	510679	2
9	FITTING, KQ2L08-01AS MALE ELBOW	513461	2
10	FITTING, KQ 2H08-02S (1/4") MALE	510072	2
11	VALVE, VHS20-F02 RESIDUAL PRESSURE RELIEF 3-PORT	510676	1
12	GAUGE, G36-10-01 (1/8") PRESSURE	510069	1
13	FITTING, GK 1381A GZ 1/4" MALE	510171	1
14	HOSE, 8 MM POLYURETHANE	R80588-6	1
15	HOSE, 6 MM POLYURETHANE	R80588-7	1
16	SILENCER, R1/8" - AN-SM-01	513462	1
17	GROMMET, RUBBER	087065	1
18	WASHER, 4.3 FLAT ZINC	F81051-2	6
19	WASHER, Z 4.1 SPLIT LOCK ZINC	F81051-1	6
20	BOLT, M4X16-8.8 HEX HEAD FULL THREAD ZINC	F81011-6	2
21	BOLT, M4X35-8.8 DIN933 HEX HEAD FULL THREAD ZINC	F81011-7	4

1 Replacement Parts

Cutting System Air Cylinder

1.12 Cutting System Air Cylinder

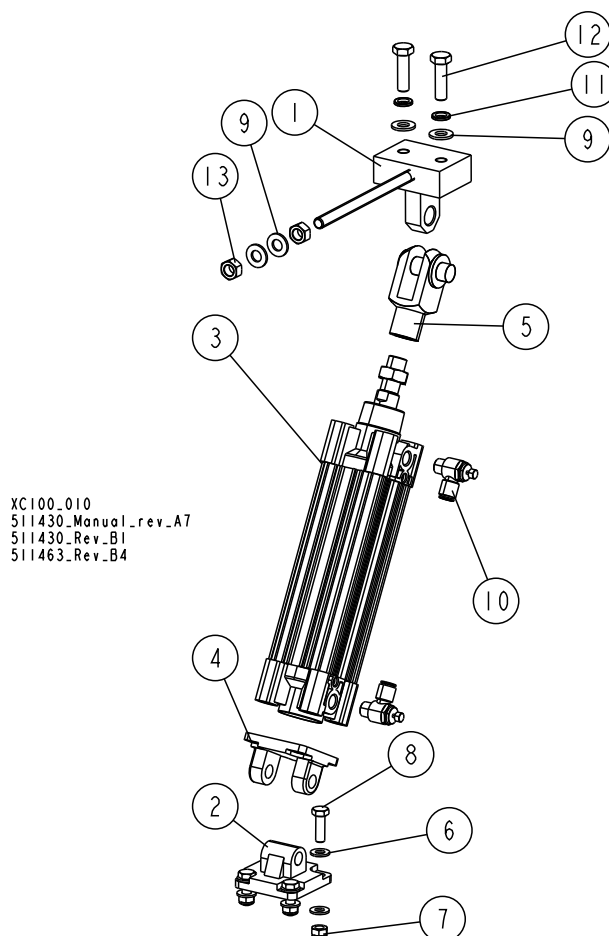

REF.	DESCRIPTION (◆ Indicates Parts Available In Assemblies Only)	PART #	QTY.
1	BLOCK WELDMENT, AIR CYLINDER UPPER MOUNT	511716-1	1
2	CLEVIS, C5050(F) MALE HEAD END	511712	1
	CYLINDER, XC100 CUTTING SYSTEM AIR	511608	1
3	CYLINDER, CP96SDB50-150 AIR	511709	1
4	CLEVIS, D5050(F) DOUBLE	511711	1
5	CLEVIS, GKM16-32 ROD	511710	1
6	WASHER, 8.4 FLAT ZINC	F81054-1	8
7	NUT, M8 8 HEX NYLON ZINC LOCK	F81032-2	4
8	BOLT, M8X25-8.8-B HEX HEAD FULL THREAD ZINC	F81002-5	4
9	WASHER, 10.5 FLAT ZINC	F81055-1	4
10	VALVE, AS2201F-02-08S AIR FLOW CONTROL	509039	2
11	WASHER, Z 10.2 SPLIT LOCK ZINC	F81055-2	2
12	BOLT, M10X35 8.8 HEX HEAD FULL THREAD ZINC	F81003-17	2
13	NUT, M10 8 HEX ZINC	F81033-3	2

1.13 Cutting System Drive

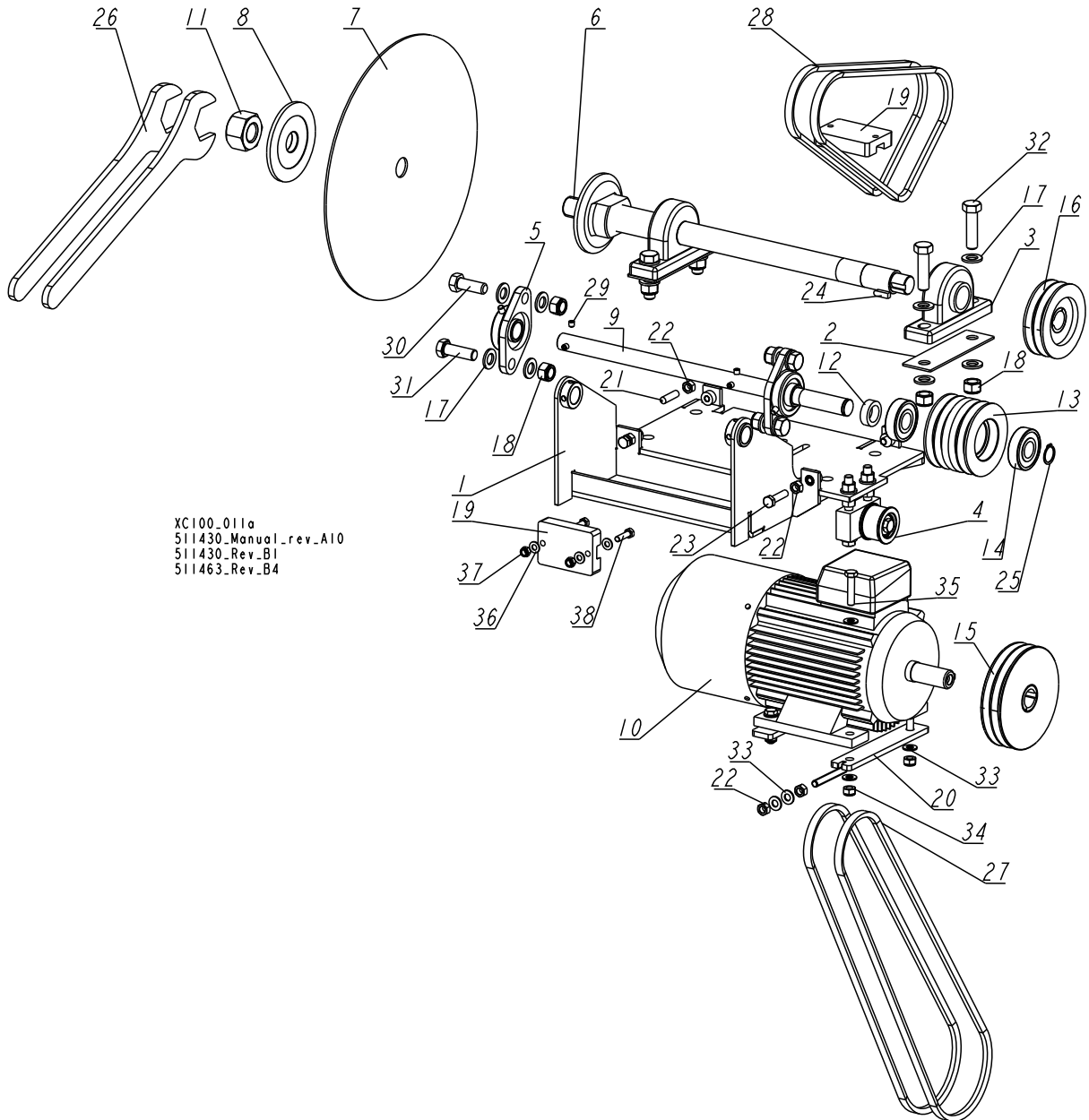

XC100-011a
511430_Manual_rev_A10
511430_Rev_B1
511463_Rev_B4

REF.	DESCRIPTION (◆ Indicates Parts Available In Assemblies Only)	PART #	QTY.
1	MOUNT WELDMENT, MAIN SHAFT	511475-1	1
2	PLATE, UCP207 BEARING SPACER	511718-1	2
3	BEARING, UCP207 (CX) W/HOUSING	511501	2
4	TENSIONER, BELT See Section 1.14	511721	1
5	BEARING, UCFL205 (COMPLEX) W/HOUSING	089124	2
6	SHAFT, MAIN W/FLANGE	512900	1
7	BLADE, (P0400015) PI-504 Z=48	511480	1
8	FLANGE, BLADE CLAMPING	511478	1



Replacement Parts

Cutting System Drive

REF.	DESCRIPTION (◆ Indicates Parts Available In Assemblies Only)	PART #	QTY.	
9	SHAFT, INTERMEDIATE	511481	1	
10	MOTOR, PSG-100 L-4 400V 50HZ 4.0KW	511482	1	
11	NUT, M30X2 SPECIAL	511479	1	
12	BUSHING, 25.4/38-12	511505-1	1	
	PULLEY, 4XSPA-A V-BELT - COMPLETE	511503	1	
13	PULLEY, 4XSPA-A DP=103.4MM V-BELT	511502	1	
14	BEARING, 6305 2RS CX	085706	2	
15	PULLEY, 150/28 SPA-2 F01745+T31105	514070	1	
16	PULLEY, 106/20 SPA-2 F01738+T31075	514069	1	
17	WASHER, 17 SPLIT LOCK ZINC	F81058-1	16	
18	NUT, M16-8 HEX NYLON ZINC LOCK	F81036-2	8	
19	BUMPER, GRENE 70 3201 0010 RUBBER	094969	2	
20	PLATE WELDMENT, MOTOR BELT TENSION	511573-1	2	
21	SCREW, M10X40-45H-GEOMET HEX SOCKET SET W/CONE POINT	F81003-61	1	
22	NUT, M10 8 HEX ZINC	F81033-3	8	
23	BOLT, M10X40-8.8 HEX HEAD FULL THREAD ZINC	F81003-16	3	
24	KEY, AB 8X7X25	099848	1	
25	RING, 25Z OUTSIDE RETAINING	F81090-22	1	
26	WRENCH, S=50	512236-1	2	
27	BELT, AVX13X1410 TOOTHED	513276	2	
28	V-BELT, HA 900	513277	2	
29	SCREW, M8X8-33H GEOMET HEX SOCKET SET W/FLAT POINT	F81014-1	4	
30	BOLT, M16X45-8.8 HEX HEAD FULL THREAD ZINC	F81006-46	3	
31	BOLT, M16X50-8.8 HEX HEAD FULL THREAD ZINC	F81006-38	1	
32	BOLT, M16X60-8.8 HEX HEAD FULL THREAD ZINC	F81006-12	4	
33	WASHER, 10.5 FLAT ZINC	F81055-1	12	
34	NUT, M10-8-B HEX NYLON ZINC LOCK	F81033-1	4	
35	BOLT, M10X45 HEX HEAD FULL THREAD ZINC	F81003-3	4	
36	WASHER, 8.4 FLAT ZINC	F81054-1	4	
37	NUT, M8 8 HEX NYLON ZINC LOCK	F81032-2	2	
38	BOLT, M8X30-5.8-B HEX HEAD FULL THREAD ZINC	F81002-2	2	

1.14 Belt Tensioner

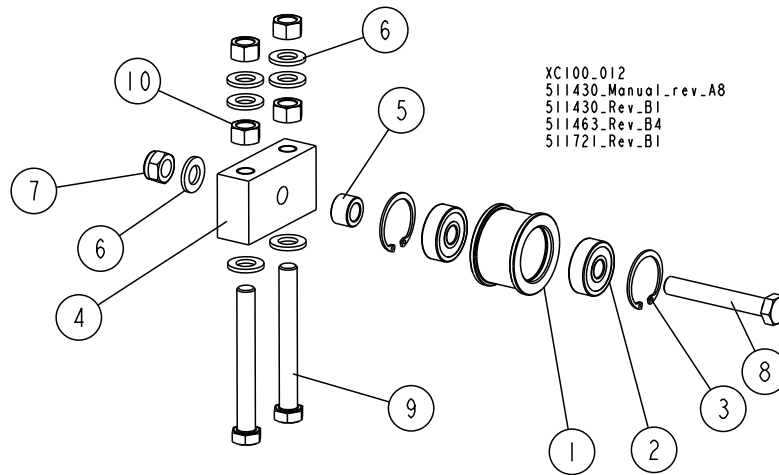

REF.	DESCRIPTION (◆ Indicates Parts Available In Assemblies Only)	PART #	QTY.
	TENSIONER, BELT	511721	1
1	ROLLER, BELT TENSIONER	511720-1	1
2	BEARING, 6301 2RSR (CX) ROLLING	100816	2
3	RING, W37 INSIDE RETAINING	F81090-55	2
4	BLOCK, BELT TENSIONER	511719-1	1
5	BUSHING, 20/12-13 SPACER	511722-1	1
6	WASHER, 13 FLAT ZINC	F81056-1	7
7	NUT, M12-8 HEX NYLON ZINC LOCK	F81034-2	1
8	BOLT, M12X80-8.8 HEX HEAD ZINC	F81004-46	1
9	BOLT, M12X100 10.9 DIN 933 HEX HEAD FULL THREAD ZINC	F81004-66	2
10	NUT, M12-8-B HEX ZINC	F81034-1	4

1 Replacement Parts

Decals, XC100

1.15 Decals, XC100

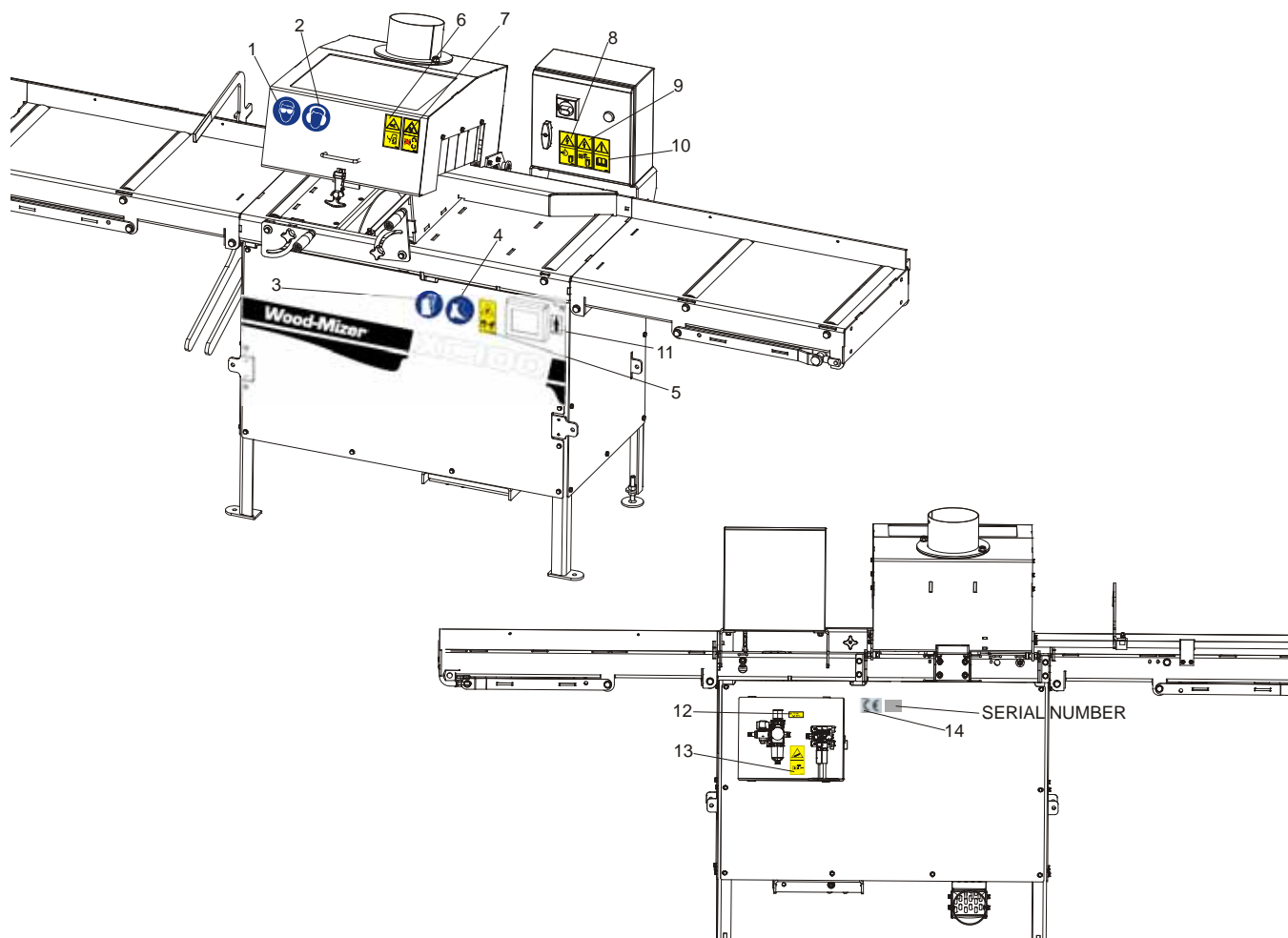

REF	DESCRIPTION (◆ Indicates Parts Available In Assemblies Only)	Part #	Qty.
	PICTOGRAPHIC DECAL KIT, XC100	514061	1
1	DECAL, EYE WARNING, SMALL	S12004G	1
2	DECAL, EAR PROTECTION WARNING (PICTOGRAM)	S12005G	1
3	DECAL, HANDS PROTECTION WARNING (PICTOGRAM)	512107	1
4	DECAL, USE SAFETY BOOTS (PICTOGRAM)	501465	1
5	DECAL, KEEP AWAY DANGER, PICTOGRAM	099221	1
6	DECAL, SAWMILL COVERS CAUTION	099220	1
7	DECAL, DANGER OF INJURY HANDS	509255	1
8	DECAL, HIGH VOLTAGE INSIDE THE ELECTRIC BOX (PICTOGRAM)	096316	1
9	DECAL, REMOVE THE PLUG BEFORE OPENING THE BOX (PICTOGRAM)	096319	1
10	DECAL, READ OPERATOR'S MANUAL (PICTOGRAM)	096317	1
11	DECAL, DIRECTION OF ROTATION	089296	1
12	DECAL, PNEUMATIC SYSTEM PRESSURE VALUE	513181	1
13	DECAL, PNEUMATIC SYSTEM UNDER PRESSURE EVEN WHEN POWER IS TURNED OFF	101176	1
14	DECAL, CE , CERTIFIED SAWMILL (SMALL)	P85070	1
15			

16				
17				
18				◆