

INDUSTRIAL PRODUCTS

**Log Infeed Deck**  
Safety, Setup, Operation,  
Maintenance & Parts Manual

---

LD12-2/3S  
LD20-2/3S

rev. A1.00  
rev. A1.00



**Safety is our #1 concern!** Read and understand all safety information and instructions before operating, setting up or maintaining this machine.

*August 2009*

*Form #1025*

# Table of Contents

# Section-Page

<b>SECTION 1</b>	<b>SAFETY</b>	<b>1-1</b>
1.1	Safety Symbols.....	1-1
1.2	Safety Instructions.....	1-2
<b>SECTION 2</b>	<b>GENERAL INFORMATION</b>	<b>2-1</b>
2.1	Component Overview.....	2-1
2.2	Overall Dimensions.....	2-2
<b>SECTION 3</b>	<b>SETUP &amp; OPERATION</b>	<b>3-1</b>
3.1	Operation (LT70HD Remote).....	3-1
3.2	Operation (LT300).....	3-3
<b>SECTION 4</b>	<b>REPLACEMENT PARTS</b>	<b>4-1</b>
4.1	Log Infeed Deck, LD12/20-2S.....	4-1
4.2	Middle Segment.....	4-4

## SECTION 1 SAFETY

### 1.1 Safety Symbols

The following symbols and signal words call your attention to instructions concerning your personal safety. Be sure to observe and follow these instructions.



**DANGER!** indicates an imminently hazardous situation which, if not avoided, will result in death or serious injury.



**WARNING!** suggests a potentially hazardous situation which, if not avoided, could result in death or serious injury.



**CAUTION!** refers to potentially hazardous situations which, if not avoided, may result in minor or moderate injury or damage to equipment.



**IMPORTANT!** indicates vital information.

**NOTE:** gives helpful information.



Warning stripes are placed on areas where a single decal would be insufficient. To avoid serious injury, keep out of the path of any equipment marked with warning stripes.

## 1.2 Safety Instructions

**NOTE:** ONLY safety instructions regarding personal injury are listed in this section. Caution statements regarding only equipment damage appear where applicable throughout the manual.

### OBSERVE SAFETY INSTRUCTIONS



**IMPORTANT!** Read the entire Operator's Manual before operating the log infeed deck. Take notice of all safety warnings throughout this manual and those posted on the machine. Keep this manual with this machine at all times, regardless of ownership.

Also read any additional manufacturer's manuals and observe any applicable safety instructions including dangers, warnings, and cautions.

Only persons who have read and understood the entire operator's manual should operate the log deck. The log deck is not intended for use by or around children.

**IMPORTANT!** It is always the owner's responsibility to comply with all applicable federal, state and local laws, rules and regulations regarding the ownership, operation of your Wood-Mizer products. All Wood-Mizer product owners are encouraged to become thoroughly familiar with these applicable laws and comply with them fully while using the machine.



## KEEP LOG DECK AND AREA AROUND LOG DECK CLEAN



**DANGER!** Maintain a clean and clear path for all necessary movement around the machine and lumber stacking areas. Failure to do so will result in serious injury.

## CAUTIONS FOR LOG DECK SETUP

**WARNING!** Securely fasten the feet of a log deck to the floor before operating the machine. Failure to do so may result in serious injury or death.

## CHECK LOG DECK BEFORE OPERATION



**DANGER!** Make sure all guards and covers are in place and secured before operating the log deck. Failure to do so may result in serious injury.



**CAUTION!** Never drop logs onto the log deck from a height more than 6" (15 mm) when loading. Failure to do so may result in damage to the log deck.



## KEEP PERSONS AWAY



**WARNING!** Keep all persons out of the path of moving equipment and logs while operating log deck. Failure to do so may result in serious injury or death.

## KEEP HANDS AWAY



**DANGER!** Always be aware of and take proper protective measures against rotating shafts, pulleys, fans, etc. Always stay a safe distance from rotating members and make sure that loose clothing or long hair does not engage rotating members resulting in possible injury.

**WARNING!** Before performing service near moving parts such as blades, pulleys, motors, belts and chains, make sure the unit is not in use. If the unit is operated and moving parts activated, serious injury may result.

## USE PROPER PROCEDURE WHEN CONDUCTING ELECTRICAL SAFETY CHECKS AND MAINTENANCE



**DANGER!** Make sure all electrical installation, service and/or maintenance work is performed by a qualified electrician and is in accordance with applicable electrical codes.

**DANGER!** Hazardous voltage inside the electric sawmill disconnect box, starter box, and at the motor can cause shock, burns, or death. Disconnect and lock out power supply before servicing! Keep all electrical component covers closed and securely fastened during mill operation.





**WARNING!** Consider all electrical circuits energized and dangerous.

**WARNING!** Never assume or take the word of another person that the power is off; check it out and lock it out.

**WARNING!** Do not wear rings, watches, or other jewelry while working around an open electrical circuit.

**KEEP SAFETY LABELS IN GOOD CONDITION**



**IMPORTANT!** Always be sure that all safety decals are clean and readable. Replace all damaged safety decals to prevent personal injury or damage to the equipment. Contact your local distributor, or call your Customer Service Representative to order more decals.



**IMPORTANT!** If replacing a component which has a safety decal affixed to it, make sure the new component also has the safety decal affixed.

**SAFETY LABELS DESCRIPTION**

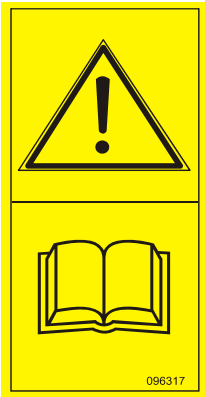

See Table 1-1. Pictographic safety labels are shown in the table below.

**TABELA 1-1**

Decal View	Decal No.	Description
	<p>096317</p>	<p>Read thoroughly the operator's manual before operating the equipment. Observe instructions and safety rules when operating.</p>

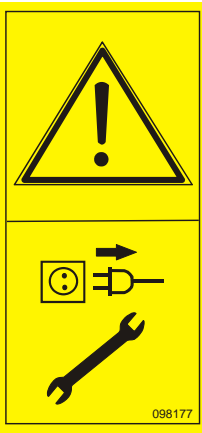

**1** Safety  
*Safety Labels Description*

**TABELA 1-1**

	<p>099220</p>	<p>Close all guards and covers prior to starting the equipment.</p>
	<p>099221</p>	<p>Keep all persons a safe distance away from work area when operating the unit.</p>
	<p>098177</p>	<p>Disconnect power supply before servicing.</p>



**TABELA 1-1**

	<p>099540</p>	<p>CAUTION! Gear danger – keep a safe distance away!</p>
	<p>P85070</p>	<p>CE safety certification</p>

## SECTION 2 GENERAL INFORMATION

### 2.1 Component Overview

With the Log Infeed Deck, you can load logs directly onto the sawmill bed. You can choose between the 12-Foot (LD12) and 20-Foot Log Infeed Decks (LD20) now available. The following manual will guide you in installation, operation, and alignment of the Log Infeed Deck.

 **WARNING!** Keep all persons out of the path of moving equipment and logs while operating the Log Infeed Deck. Failure to do so may result in serious injury or death.

See Figure 2-1. The main components of the Log Infeed Deck are shown below.

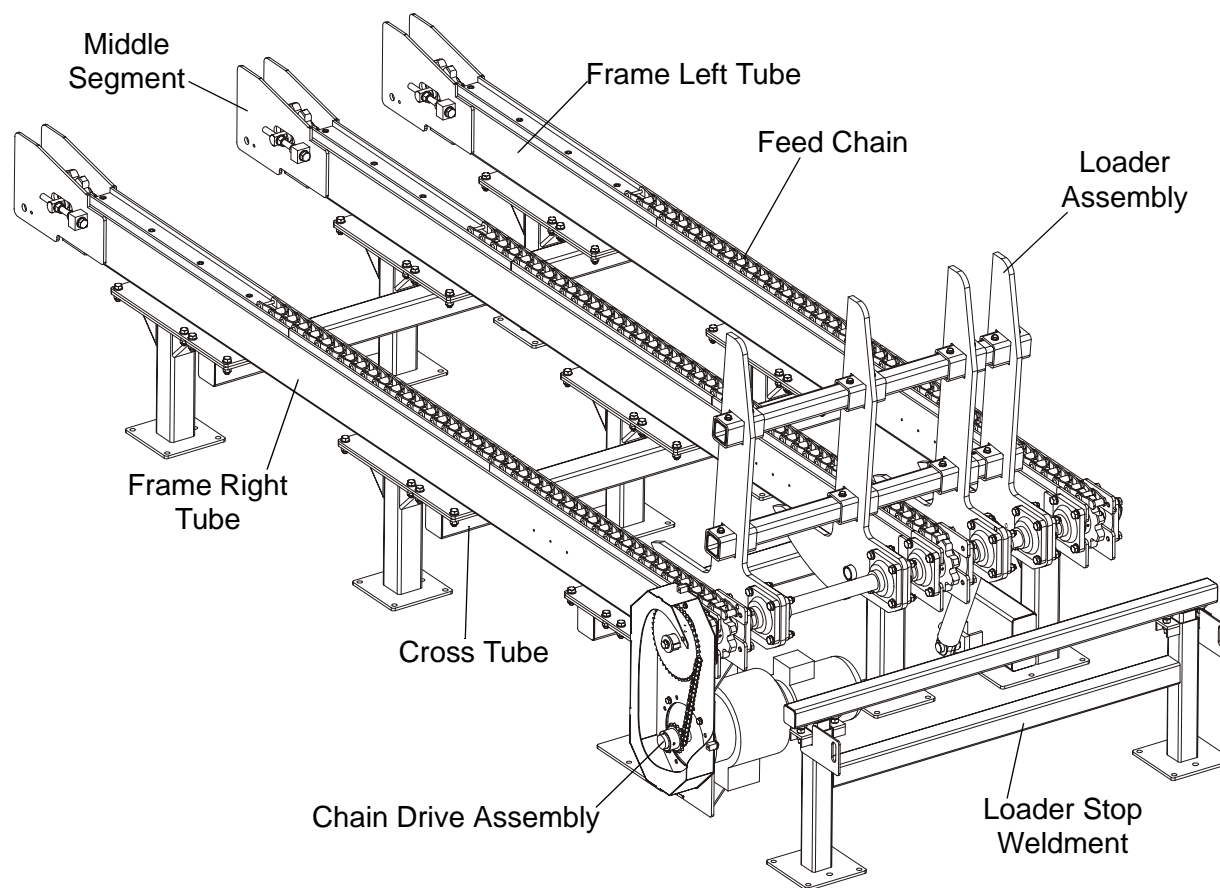

**FIG. 2-1 LD12-3C**

## 2.2 Overall Dimensions

See Figure 2-1. The overall dimensions of the LD12-2C Log Deck are shown below.

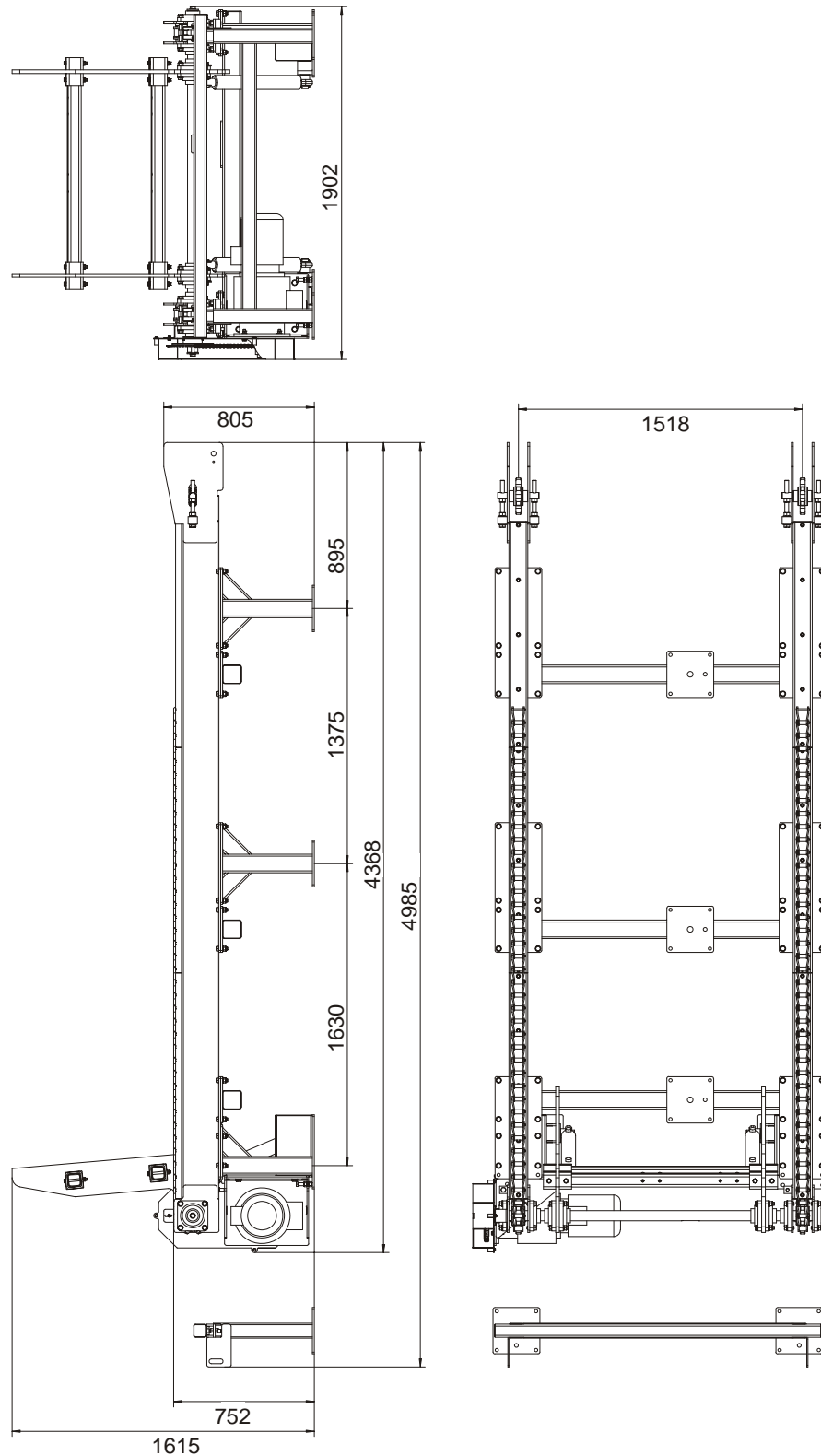
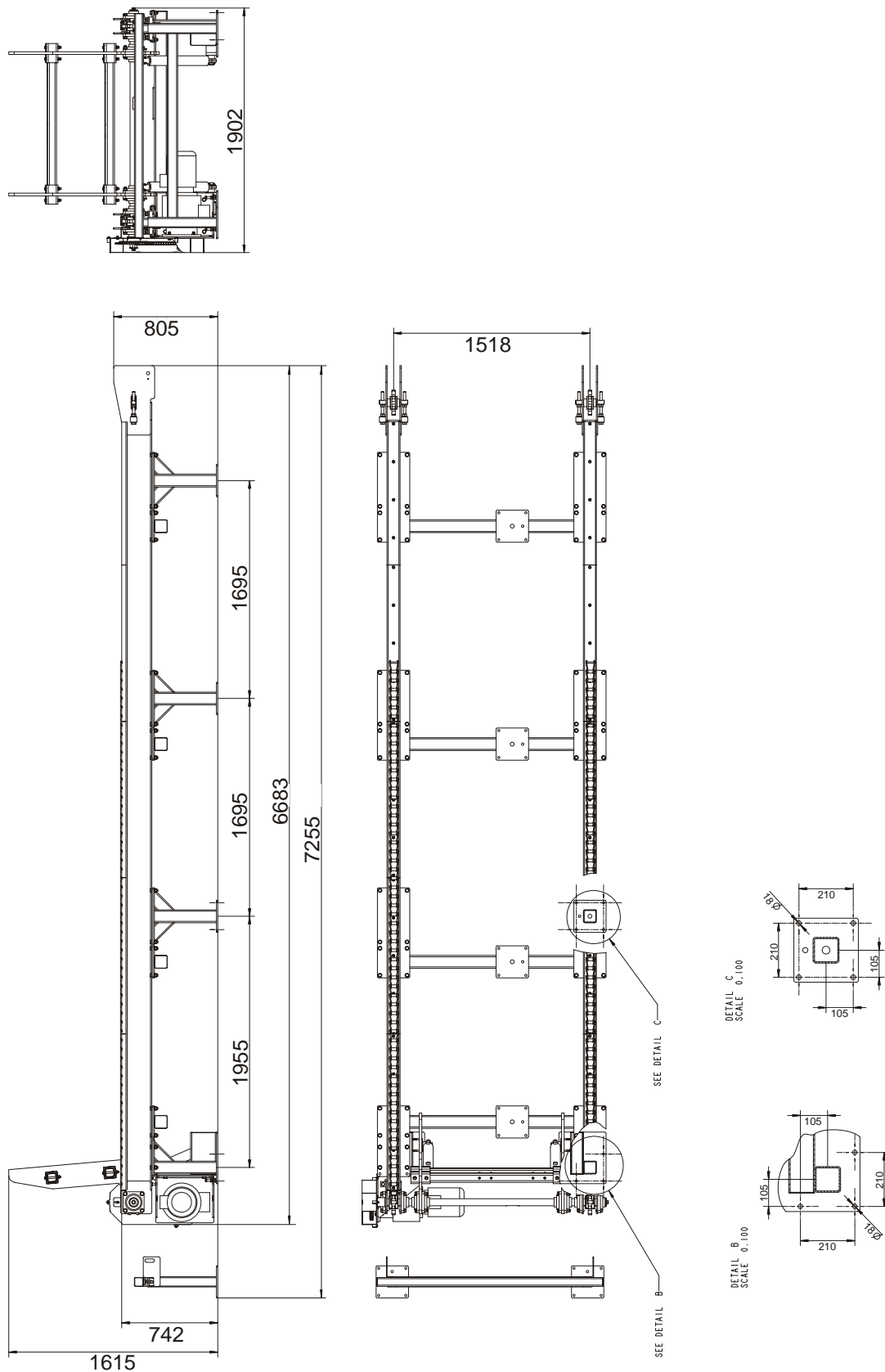

FIG. 2-1 LD12-2C LOG INFEEED DECK

See Figure 2-2. The figure below shows overall dimensions of the LD20-2C Log Deck.



**FIG. 2-2 LD20-2C LOG INFED DECK**

See Figure 2-3. Weight are listed below.

<b>Model</b>	<b>Weight</b>
<b>LD12</b>	1200 kg

## SECTION 3 SETUP & OPERATION

### 3.1 Operation (LT70HD Remote)



**DANGER!** Always be aware of and take proper protective measures against rotating shafts, pulleys, fans, etc. Always stay a safe distance from rotating members and make sure that loose clothing or long hair does not engage rotating members resulting in possible injury.



**WARNING!** Keep all persons out of the path of moving equipment and logs while operating log deck. Failure to do so may result in serious injury or death.



**CAUTION!** Never drop logs onto the log deck from a height more than 6" (15 mm) when loading. Failure to do so may result in damage to the log deck.

**See Figure 3-1.** Use the “HEAD/BED” button to activate the bed mode. To operate the drive chain use the chain switch. Turn the switch to the “R” position to move the log toward the sawmill bed, release the switch to stop the log. Turn the switch to the “L” position to move the the log backward. Press and hold the left joystic button. Move the right joystick right to move the log on the sawmills bed.

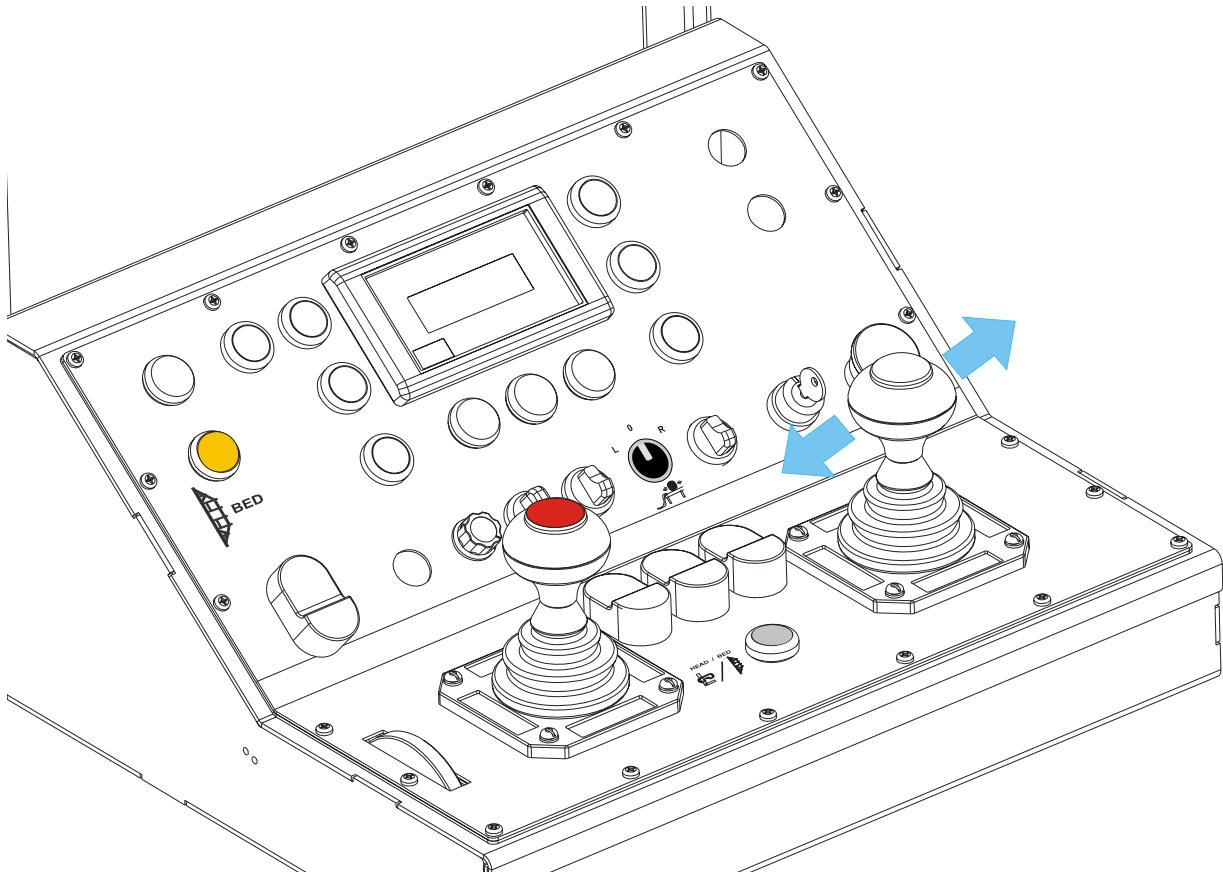



**FIG. 3-1**

# 3 Operation & Setup

## Operation (LT300)

### 3.2 Operation (LT300)

 **DANGER!** Always be aware of and take proper protective measures against rotating shafts, pulleys, fans, etc. Always stay a safe distance from rotating members and make sure that loose clothing or long hair does not engage rotating members resulting in possible injury.

 **WARNING!** Keep all persons out of the path of moving equipment and logs while operating log deck. Failure to do so may result in serious injury or death.

 **CAUTION!** Never drop logs onto the log deck from a height more than 6" (15 mm) when loading. Failure to do so may result in damage to the log deck.

After the Log Infeed Deck is installed, you can start to operate the unit. Use the right joystick to control the log handling functions. Push the top button on the left joystick to change to bed mode. While in bed mode, push the joystick forward to lower the log loader, pull it back to raise the log loader.

See Figure 3-2.

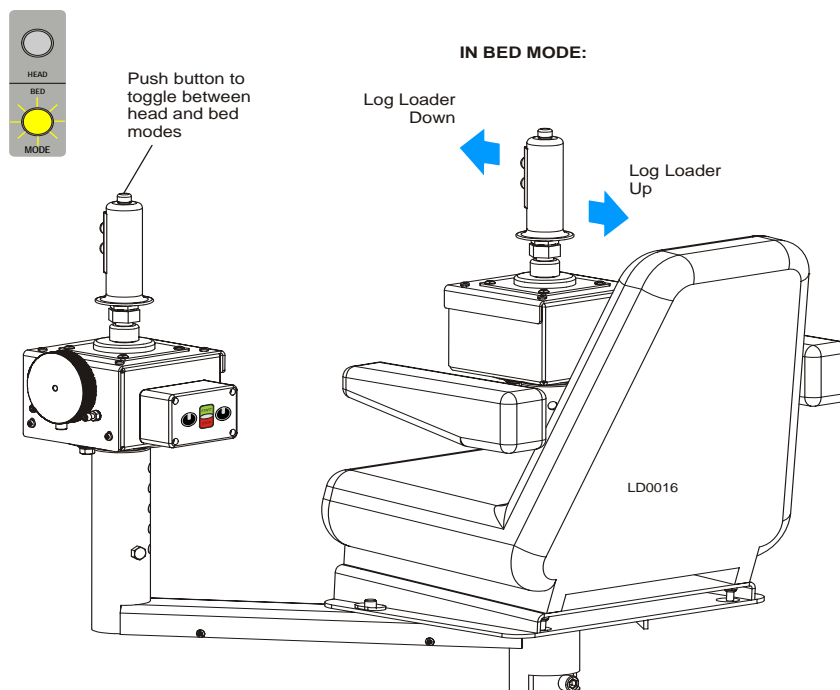

FIG. 3-2



To control the log deck hydraulic drive chain use the chain switch. Turn the switch right to move the log toward the sawmill bed, release the switch to stop the log. Turn the switch left to move the the log backward. **NOTE:** Push the START button located on the LT300 control box to turn on electrical power to the machine. Then push button control station activates the log deck feed chain only when the LT300 sawmill is powered on.

See Figure 3-3.



FIG. 3-3

# SECTION 4 REPLACEMENT PARTS

## 4.1 Log Infeed Deck, LD12/20-2S

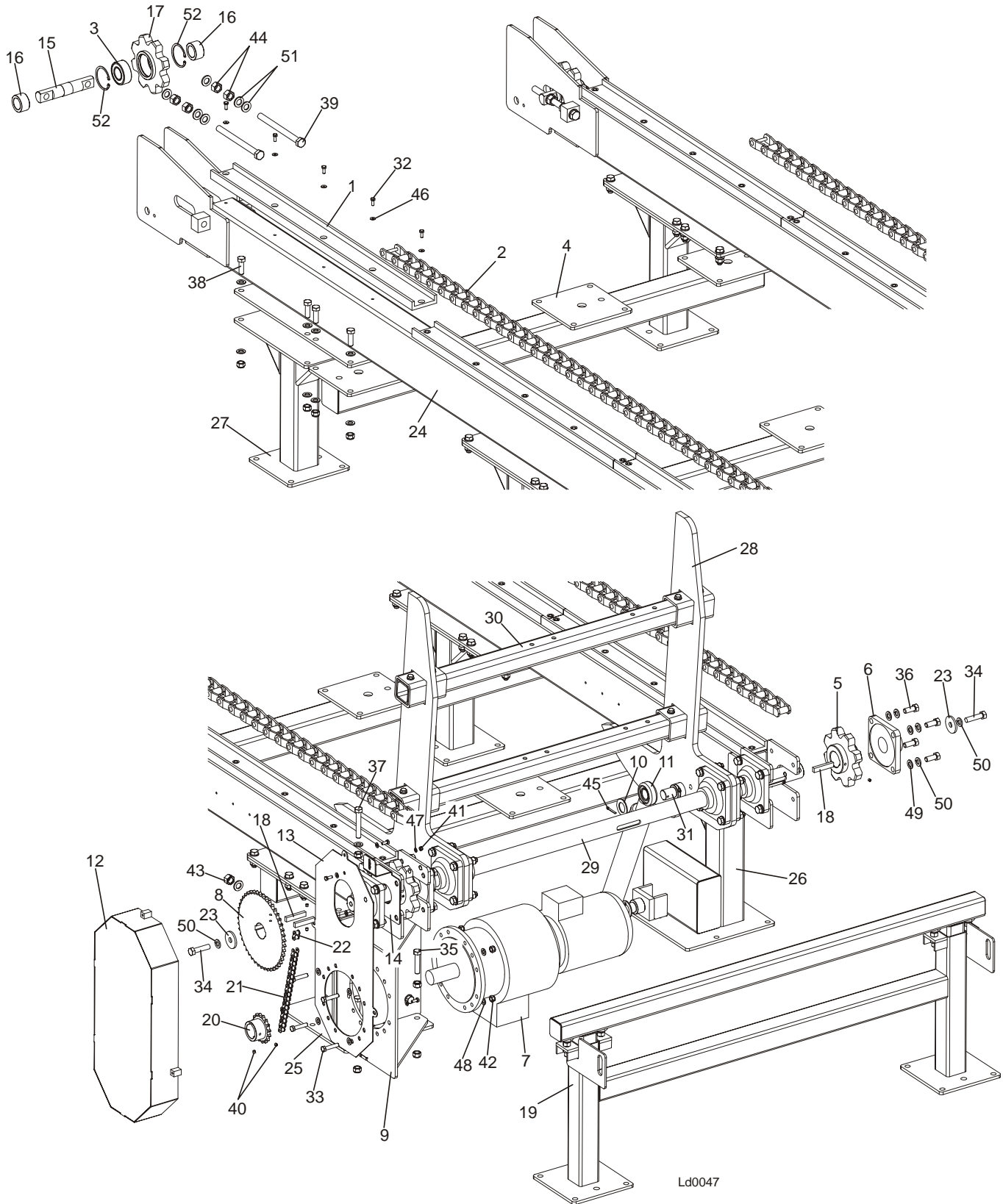

Ld0047

REF.	DESCRIPTION (◆ Indicates Parts Available In Assemblies Only)	PART #	QTY.	
	<b>LOG INFEED RECK, LD12-2S</b>	098940	1	
	<b>LOG INFEED DECK, LD20-2S</b>	100417	1	
1	CHANNEL, UHMW CONVEYOR (LD12/20)	033722	6/8	
	TUBE, 4 ODX42 1/2 (LD20)	033755	2	
2	CHAIN, LOG DECK 8290MM 125 LINKS (LD12)	504581	2	
	CHAIN, LOG DECK 12930MM 195 LINKS (LD20)	504583	2	
3	BEARING, 3208B.2RSRTNG NSK	088449	2	
4	CROSS TUBE WELDMENT, LOG INFEED DECK	089880-1	3/4	
5	SPROCKET, Z8 PAINTED	089888-1	2	
6	BEARING, UCF 211 W/HOUSING (55 DIAMETER SHAFT)	089889	4	
7	MOTOREDUCER, SBCM 180/112M-4/32	089892	1	
8	SPROCKET, 12B Z45 PAINTED	089894-1	1	
9	BRACKET, MOTOR MOUNT	089897-1	1	
10	WASHER, 36mm DIA. ZINC-PLATED	089903-1	4	
11	CYLINDER, CJ2F-16-63/36/320Z UE2-63W ROD END	089904	2	
12	COVER, CHAIN DRIVE GUARD	089905-1	1	
13	PLATE, CHAIN DRIVE GUARD	089909-1	2	
14	BRACKET, CHAIN DRIVE GUARD MOUNT	089910-1	1	
15	SHAFT, IDLER SPROCKET ZINC-PLATED	089915-1	2	
16	BUSHING, ZINC-PLATED SPACER	089916-1	4	
17	SPROCKET, Z8 REAR PAINTED	089919-1	2	
18	KEY, B 16x10x80 PARALLEL	089921	5	
19	STOP WLDMT, LOG INFEED DECK - COMPLETE	089930	1	
20	SPROCKET, 12B Z16 PAINTED	090303-1	1	
21	CHAIN, 12B-1-69 (1.31 r.m.)	090711	1	
22	LINK, 12B-1PZ	090713	1	
23	WASHER, SPECIAL ZINC-PLATED	098012-1	4	
24	TUBE, SLPLD3.6 FRAME	098925-1	2	
	TUBE, SLPLD6.0 FRAME	099766-1	2	
25	LEG, LD W/MOUNTING PLATE PTD	098927-1	1	
26	LEG, LD12/20 FRONT PAINTED	098928-1	1	
27	LEG, LD12/20 H=500mm SIDE	098929-1	4/6	
28	ARM, LD12/20 LOADER - COMPLETE	099242	2	
29	SHAFT, LT70/300 LOG INFEED DECK MAIN	099243	1	
30	TUBE, LOADER ARMS CONNECTION	099245-1	2	
31	PIN, LD CYLINDER MOUNTING ZINC-PLATED	099482-1	1	
32	BOLT, M8x20-5.8 HEX HEAD FULL THREAD ZINC	F81002-1	34/52	
33	BOLT, M12x55-8.8 HEX HEAD ZINC	F81004-12	4	
34	BOLT, M16x65-8.8-B HEX HEAD FULL THREAD ZINC	F81006-1	2	
35	BOLT, M16x75-8.8-B HEX HEAD FULL THREAD ZINC	F81006-10	2	
36	BOLT, M16x40-8.8 HEX HEAD FULL THREAD ZINC	F81006-13	16	
37	BOLT, M16x100-8.8 HEX HEAD FULL THREAD ZINC	F81006-2	1	
38	BOLT, M16x50-8.8 HEX HEAD FULL THREAD ZINC	F81006-7	54/70	
39	BOLT, M20x240-8.8 HEX HEAD FULL THREAD ZINC	F81007-1	4	
40	SCREW, M8x8 45H GEOMET HEX SOCKET SET FLAT POINT	F81014-1	8	
41	NUT, M8-8-B HEX NYLON ZINC LOCK	F81032-2	1	
42	NUT, M12-8 HEX NYLON ZINC LOCK	F81034-2	4	
43	NUT, M16-8 HEX NYLON ZINC LOCK	F81036-2	57/73	

**4****Replacement Parts***Log Infeed Deck, LD12/20-2S*

44	NUT, M20-8 HEX ZINC	F81037-1	8	
45	PIN, S-Zn 5x40 COTTER	F81043-31	4	
46	WASHER, 6.5 FLAT ZINC SPECIAL	F81053-11	30/48	
47	WASHER, 8.4 FLAT ZINC	F81054-1	5	
48	WASHER, 13 FLAT ZINC	F81056-1	8	
49	WASHER, 17 FLAT ZINC	F81058-1	121/153	
50	WASHER, 16.3 SPLIT LOCK ZINC	F81058-2	20	
51	WASHER, 21 FLAT ZINC	F81059-2	12	
52	RING, W80 INSIDE RETAINING	F81090-25	4	

## 4.2 Middle Segment

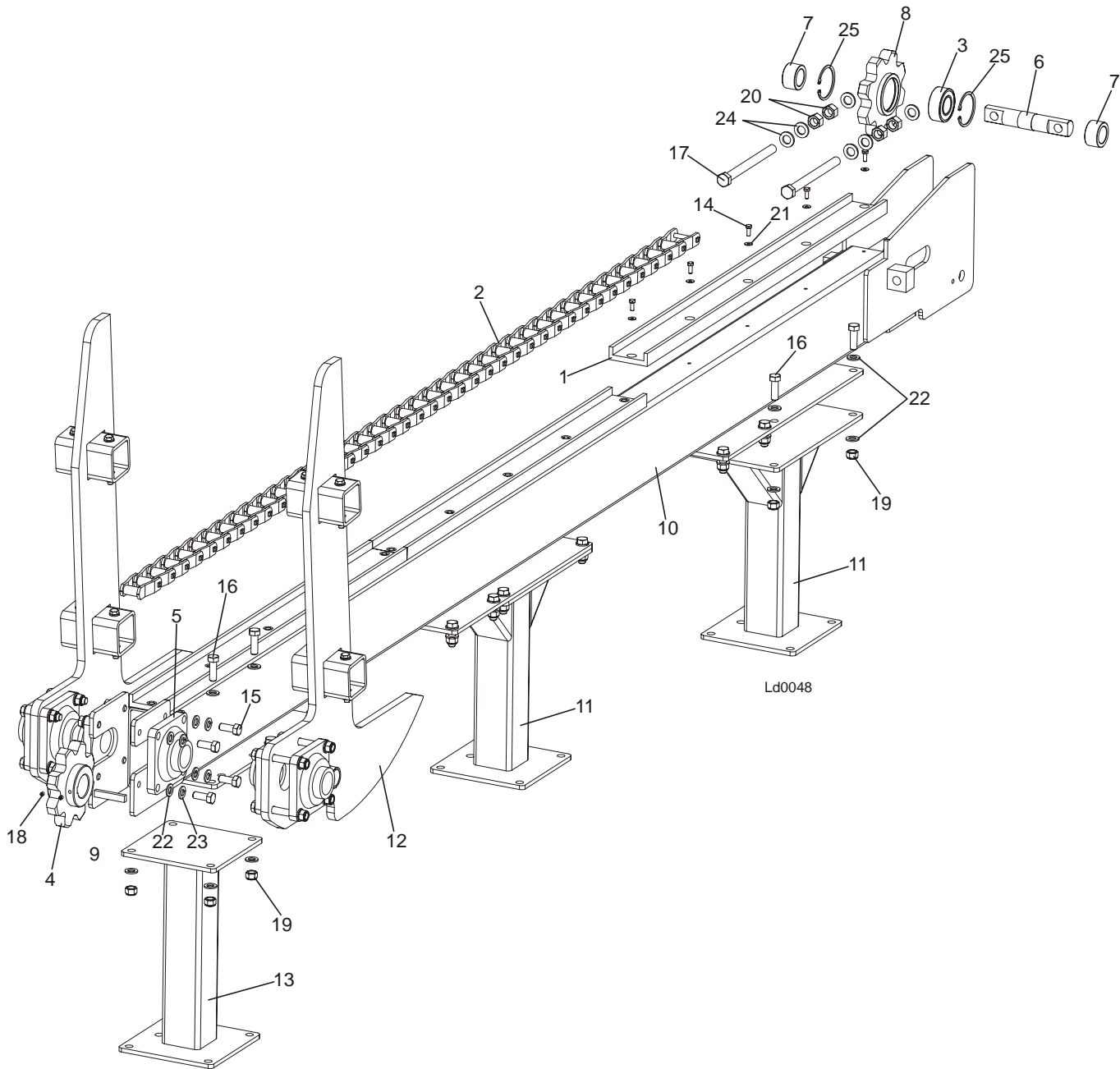

REF.	DESCRIPTION (◆ Indicates Parts Available In Assemblies Only)	PART #	QTY.
	<b>MIDDLE SEGMENT, LD12 - COMPLETE</b>	099244	1
	<b>MIDDLE SEGMENT, LD20 - COMPLETE</b>	100416	1
1	CHANNEL, UHMW CONVEYOR (LD12/20)	033722	3/4
	TUBE, 4 ODX42 1/2 (LD20)	033755	1
2	CHAIN, 12FT INFEEDECK (LD12)	033760	1
	CHAIN, 20FT INFEEDECK (LD20)	035762	1
3	BEARING, 3208B.2RSRTNG NSK	088449	1
4	SPROCKET, Z8 PAINTED	089888-1	1

5	BEARING, UCF 211W/HOUSING (55 DIA. SHAFT)	089889	2	
6	SHAFT, TENSION SPROCKET ZINC-PLATED	089915-1	1	
7	BUSHING, SPROCKET SPACER ZINC-PLATED	089916-1	2	
8	SPROCKET, Z8 CHAIN TENSION PTD	089919-1	1	
9	KEY, B 16x10x80 PARALLEL	089921	1	
10	TUBE, SLPLD3.6 FRAME	098925-1	1	
	TUBE, SLPLD6.0 FRAME	099766-1	1	
11	LEG, LD12/20 H=500mm SIDE	098929-1	2/3	
12	ARM, LD12/20 LOADER - COMPLETE	099242	2	
13	LEG, MIDDLE SEGMENT FRONT	099247-1	1	
14	BOLT, M8x20-5.8 HEX HEAD FULL THREAD ZINC	F81002-1	15/24	
15	BOLT, M16x40-8.8 HEX HEAD FULL THREAD ZINC	F81006-13	8	
16	BOLT, M16x50-8.8 HEX HEAD FULL THREAD ZINC	F81006-7	24/28	
17	BOLT, M20x240-8.8 HEX HEAD FULL THREAD ZINC	F81007-1	2	
18	SCREW, M8x8 45H GEOMET HEX SOCKET SET FLAT POINT	F81014-1	2	
19	NUT, M16-8 HEX NYLON ZINC LOCK	F81036-2	24/28	
20	NUT, M20-8 HEX ZINC	F81037-1	4	
21	WASHER, 6.5 SPECIAL FLAT ZINC	F81053-11	15/24	
22	WASHER, 17 FLAT ZINC	F81058-1	56/64	
23	WASHER, 16.3 SPLIT LOCK ZINC	F81058-2	8	
24	WASHER, 21 FLAT ZINC	F81059-2	6	
25	RING, W80 INSIDE RETAINING	F81090-25	2	



## EC declaration of conformity according to EC Machinery Directive 2006/42/EC

We herewith declare,

Wood-Mizer Industries sp. Z O.O.  
114 Nagorna street, 62-600 Kolo; Poland.

That the following described machine in our delivered version complies with the appropriate basic safety and health requirements of the EC Machinery Directive 2006/42/EC based on its design and type, as brought into circulation by us. In case of alteration of the machine, not agreed by us, this declaration is no longer valid.

Designation of the machine: **Log Deck**  
TYPE: LD.....  
No. of manufacturer: .....

Applicable EC Directives: EC Machinery Directive 2006/42/EC  
EC Low-Voltage Directive 2006/95/EC  
EC Electromagnetic Compatibility Directive  
2004/108/EC

Responsible for Technical Documentation: Roman Frontczak / R&D Director

Date/Authorized Signature: 29. 12. 2009



Title : R&D Director