

# Horizontal Resaw

## HR700

### Parts List

---

<b>HR700E20S</b>	<b>rev. A2.00</b>
<b>(HR1-6E20S)</b>	<b>rev. A2.00</b>
<b>HR700E25</b>	<b>rev. A2.00</b>
<b>(HR1-6E25)</b>	<b>rev. A2.00</b>

---



**Safety is our #1 concern!** Read and understand all safety information and instructions before operating, setting up or maintaining this machine.

*Form #1023*

# Table of Contents

# Section-Page

## SECTION 1 REPLACEMENT PARTS

2-1

1.1	How To Use The Parts List .....	2-1
1.1	Sample Assembly .....	2-1
1.2	Main Module Base .....	2-2
1.3	Main Module Feed Track, HR700 .....	2-3
1.4	Additional Module Base, HR700 .....	2-5
1.5	Additional Module Feed Track, HR700 .....	2-6
1.6	Feed Chain Drive Assembly, HR700 .....	2-8
1.7	HR700 Hold-Down Rollers .....	2-10
1.8	Air Supply Assembly .....	2-11
1.9	Drive Roller, HR700 .....	2-12
1.10	Hold-Down Roller, 126 (Optional) .....	2-15
1.11	Up/Down System, HR700 .....	2-17
1.12	Blade Guide Assembly, Idle Side .....	2-19
1.13	Blade Guide Assembly, Drive Side .....	2-20
1.14	Blade Wheel Assembly, Drive Side .....	2-21
1.15	Blade Wheel Assembly, Idle Side .....	2-22
1.16	Hydraulic Blade Tensioner Assembly .....	2-23
1.17	Hydraulic Blade Tensioner .....	2-25
1.18	Hydraulic Pump Assembly .....	2-27
1.19	Water Bottle Assembly (Option) .....	2-29
1.20	Blade Lube System .....	2-30
1.21	HR700 Saw Head Warning Decals .....	2-32
1.22	Pneumatic System Decals .....	2-34
1.23	HR700 Saw Head .....	2-35
1.24	Front Blade Housing Cover .....	2-36
1.25	Adjustable Saw Head Guide Rollers .....	2-38
1.26	Fixed Saw Head Guide Rollers .....	2-39
1.27	HR700 Vertical Mast .....	2-40
1.28	Drive Belt Guard .....	2-42
1.29	Blade Guide Arm .....	2-43
1.30	E20 (Standard) & E25 (Option) Motors .....	2-45
1.31	E15 Motor Assembly (Option) .....	2-46
1.32	Idle Roller Table, SLPIRT .....	2-47
1.33	Cross Roller Table, SLPCRT .....	2-49
1.34	Control Box .....	2-51
1.35	Multisetwork .....	2-53
1.36	Up/Down Drive Assembly, HR700 (Optional) .....	2-54
1.37	Single Blade Tension Assembly (Optional for non-CE Markets) .....	2-58
1.38	Oil Flow Control Valve (Optional for First Saw Head) .....	2-59
1.39	Oil Flow Control Valve (Optional for Second Saw Head) .....	2-60
1.40	Ground Cable .....	2-61

**Table of Contents**

**Section-Page**

1.41 Electric Boxes .....2-62

**SECTION 2      SIDE FENCE (CE VERSION ONLY)      3-1**

2.1 Side Fence .....3-1

2.2 Moving Side Fence Support Bracket .....3-2

2.3 Fixed Side Fence Support Bracket & Front Connection Bracket .....3-4

2.4 Fixed Side Fence Support Bracket & Rear Connection Bracket .....3-5

2.5 Middle Support Bracket .....3-6

2.6 Side Fence Barriers .....3-8

## SECTION 1 REPLACEMENT PARTS

### 1.1 How To Use The Parts List

- Go to the appropriate section and locate the part in the illustration.
- Use the number pointing to the part to locate the correct part number and description in the table.
- Parts shown indented under another part are included with that part.
- Parts marked with a diamond (◆) are only available in the assembly listed above the part.

See the sample table below. Sample Part #A01111 includes part F02222-2 and subassembly A03333. Subassembly A03333 includes part S04444-4 and subassembly K05555. The diamond (◆) indicates that S04444-4 is not available except in subassembly A03333. Subassembly K05555 includes parts M06666 and F07777-77. The diamond (◆) indicates M06666 is not available except in subassembly K05555.

1.1 Sample Assembly				
REF.	DESCRIPTION (◆ Indicates Parts Available In Assemblies Only)	PART #	QTY	
	<b>SAMPLE ASSEMBLY, COMPLETE (INCLUDES ALL INDENTED PARTS BELOW)</b>	<b>A01111</b>	1	
1	Sample Part	<b>F02222-22</b>	1	
2	Sample Subassembly (Includes All Indented Parts Below)	<b>A03333</b>	1	
	Sample Part (◆ Indicates Part Is Only Available With A03333)	<b>S04444-4</b>	1	◆
3	Sample Subassembly (Includes All Indented Parts Below)	<b>K05555</b>	1	
	Sample Part (◆ Indicates Part Is Only Available With K05555)	<b>M06666</b>	2	◆
4	Sample Part	<b>F07777-77</b>	1	

#### **To Order Parts:**

From Europe call your local distributor or our European Headquarters and Manufacturing Facility in Kolo, Nagórna 114 St, Poland at **+48-63-2626000** or **+48-3912-1319**. From the continental U.S., call at **1-800-448-7881**. Have your customer number, vehicle identification number, and part numbers ready when you call. From other international locations, contact the Wood-Mizer distributor in your area for parts.



**CAUTION!** It is strongly recommended that only original spare parts be used.

1.2 Main Module Base

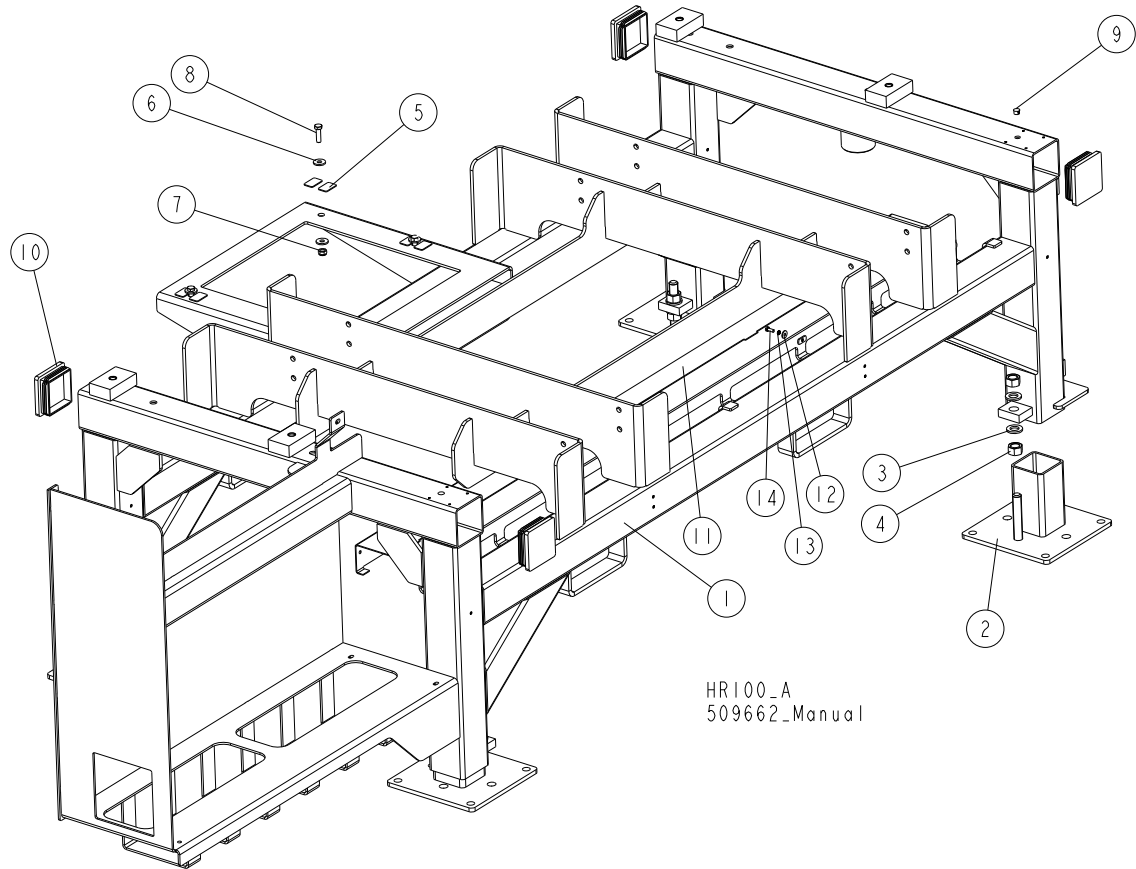

HR100\_A  
509662.Manual

REF.	DESCRIPTION (◆ Indicates Parts Available In Assemblies Only)	PART #	QTY
	<b>BASE, HR700-2 MAIN MODULE - COMPLETE</b>	<b>509679</b>	<b>1</b>
1	FRAME, HR700-2 MAIN MODULE BASE	509680-1	1
2	FOOT, LEG ADJUSTABLE	099547-1	4
3	WASHER, 21 FLAT ZINC	F81059-2	8
4	NUT, M20-8 HEX ZINC	F81037-1	8
5	WASHER, SELF-ADHESIVE CORK	502881	8
6	WASHER, 10.5 SPECIAL FLAT ZINC	F81055-6	8
7	NUT, M10-8-B HEX NYLON ZINC LOCK	F81033-1	4
8	BOLT, M10X35 8.8 HEX HEAD FULL THREAD ZINC	F81003-17	4
9	PLUG, 12.7 HOLE HEYMAN DP-812	086773	2
10	CAP, 100X100 #199200 SQUARE	090694	4
	<b>COVER, CABLE/HOSE DUCT - COMPLETE</b>	<b>515182</b>	<b>1</b>
11	COVER, CABLE/HOSE DUCT	515183-1	1
12	WASHER, 6.5 SPECIAL FLAT ZINC	F81053-11	4
13	WASHER, Z6.1 SPLIT LOCK ZINC	F81053-3	4
14	BOLT, M6X16-8.8 HEX HEAD FULL THREAD ZINC	F81001-15	4

# 1

## REPLACEMENT PARTS

### Main Module Feed Track, HR700

### 1.3 Main Module Feed Track, HR700

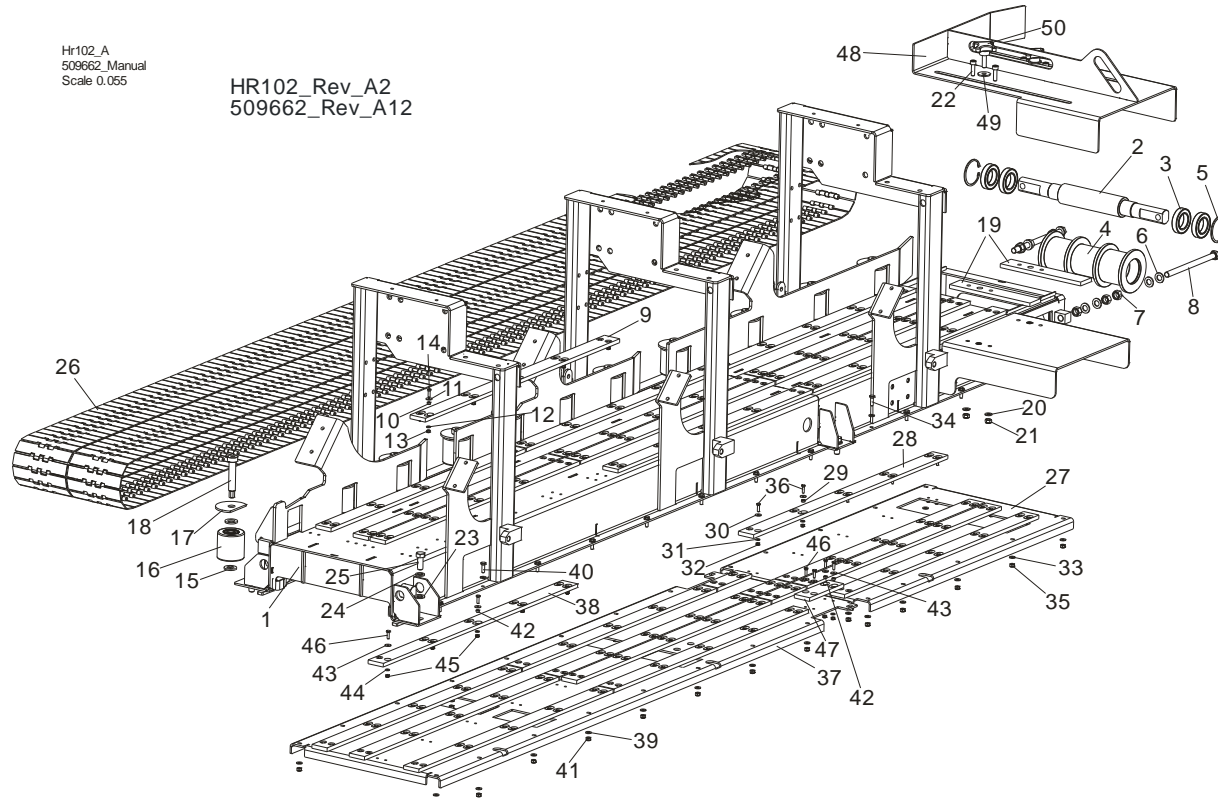

Hr102\_A  
509662\_Manual  
Scale 0.055

HR102\_Rev\_A2  
509662\_Rev\_A12

REF.	DESCRIPTION (◆ Indicates Parts Available In Assemblies Only)	PART #	QTY
	<b>TRACK, HR700 MAIN MODULE FEED - COMPLETE</b>	<b>509595</b>	<b>1</b>
1	TRACK, HR700-2 MAIN MODULE FEED	509596-1	1
	<b>TENSIONER, HR700 CHAIN - COMPLETE</b>	<b>509637</b>	<b>1</b>
2	SHAFT, TENSION PULLEY ZINC-PLATED	509639-1	1
3	BEARING, 6009.2RSR (FAG) ROLLING	096025	4
4	PULLEY, CHAIN TENSION ZINC-PLATED	509638-1	1
5	RING, W75 INSIDE RETAINING	F81090-41	2
6	WASHER, 17 SPLIT LOCK ZINC	F81058-1	8
7	NUT, M16-8 HEX ZINC	F81036-1	6
8	BOLT, ISO 4017-M16X240-8.8-A2E. HEX HEAD FULL THREAD	F81006-29	2
9	PAD, FEED TRACK PLASTIC	092080	12
10	BUSHING, 6.2X10X5 ZINC-PLATED SPACER	503674-1	96
11	WASHER, 6.5 SPECIAL FLAT ZINC	F81053-11	120
12	WASHER, 6.4 FLAT ZINC	F81053-1	120
13	NUT, M6-8-B HEX NYLON ZINC LOCK	F81031-2	120
14	BOLT, M6X20 8.8 HEX HEAD FULL THREAD ZINC	F81001-2	118
15	WASHER, 21 FLAT ZINC	F81059-2	22
16	ROLLER, 80 R80-80-80 (ZABI) PLASTIC	099429	11
17	PLATE, GUIDE ROLLER COVER ZINC-PLATED	099441-1	11
18	BOLT, 20/M16X90 12.9 ISO7379 (BOSSARD) SHOULDER	F81006-30	11

# REPLACEMENT PARTS

*Main Module Feed Track, HR700*

1

REF.	DESCRIPTION (◆ Indicates Parts Available In Assemblies Only)	PART #	QTY	
19	WASHER, LOG GUIDE SLIDE	099478	2	
20	WASHER, 10.5 FLAT ZINC	F81055-1	4	
21	NUT, M10-8-B HEX NYLON ZINC LOCK	F81033-1	4	
22	SCREW, M10X35-8.8 HEX SOCKET HEAD CAP ZINC	F81003-56	4	
23	WASHER, 17 FLAT ZINC	F81058-1	4	
24	WASHER, 16.3 SPLIT LOCK ZINC	F81058-2	4	
25	BOLT, M16X40-8.8 HEX HEAD FULL THREAD ZINC	F81006-13	4	
26	CHAIN, ACCATE S802 K750 7.94.110 (204-LINK)	099080	2	
	<b>PLATE, SHORT CHAIN SUPPORT - COMPLETE</b>	<b>509624</b>	<b>1</b>	
27	PLATE, SHORT CHAIN SUPPORT	509626-1	1	
28	PAD, FEED TRACK PLASTIC	092080	4	
29	BUSHING, 6.2X10X5 ZINC-PLATED SPACER	503674-1	32	
30	WASHER, 6.5 SPECIAL FLAT ZINC	F81053-11	40	
31	WASHER, 6.4 FLAT ZINC	F81053-1	40	
32	NUT, M6-8-B HEX NYLON ZINC LOCK	F81031-2	40	
33	WASHER, 8.4 FLAT ZINC	F81054-1	20	
34	BOLT, M8X25-8.8-B HEX HEAD FULL THREAD ZINC	F81002-5	10	
35	NUT, M8 8 HEX NYLON ZINC LOCK	F81032-2	10	
36	BOLT, M6X20 8.8 HEX HEAD FULL THREAD ZINC	F81001-2	42	
	<b>PLATE, LONG CHAIN SUPPORT - COMPLETE</b>	<b>509620</b>	<b>1</b>	
37	PLATE, LONG CHAIN SUPPORT	509622-1	1	
38	PAD, FEED TRACK PLASTIC	092080	8	
39	WASHER, 8.4 FLAT ZINC	F81054-1	36	
40	BOLT, M8X25-8.8-B HEX HEAD FULL THREAD ZINC	F81002-5	18	
41	NUT, M8 8 HEX NYLON ZINC LOCK	F81032-2	18	
42	BUSHING, 6.2X10X5 ZINC-PLATED SPACER	503674-1	72	
43	WASHER, 6.5 SPECIAL FLAT ZINC	F81053-11	96	
44	WASHER, 6.4 FLAT ZINC	F81053-1	96	
45	NUT, M6-8-B HEX NYLON ZINC LOCK	F81031-2	96	
46	BOLT, M6X20 8.8 HEX HEAD FULL THREAD ZINC	F81001-2	96	
47	PAD, FEED TRACK PLASTIC - SHORT	099430	4	
48	BRACKET, HR700 LOG GUIDE	511819-1	1	
49	WASHER, 13 SPECIAL FLAT ZINC	F81056-14	2	
50	KNOB, SR1580 80X40M12 (466408 MOSS)	100848	2	

# 1 REPLACEMENT PARTS

## Additional Module Base, HR700

### 1.4 Additional Module Base, HR700

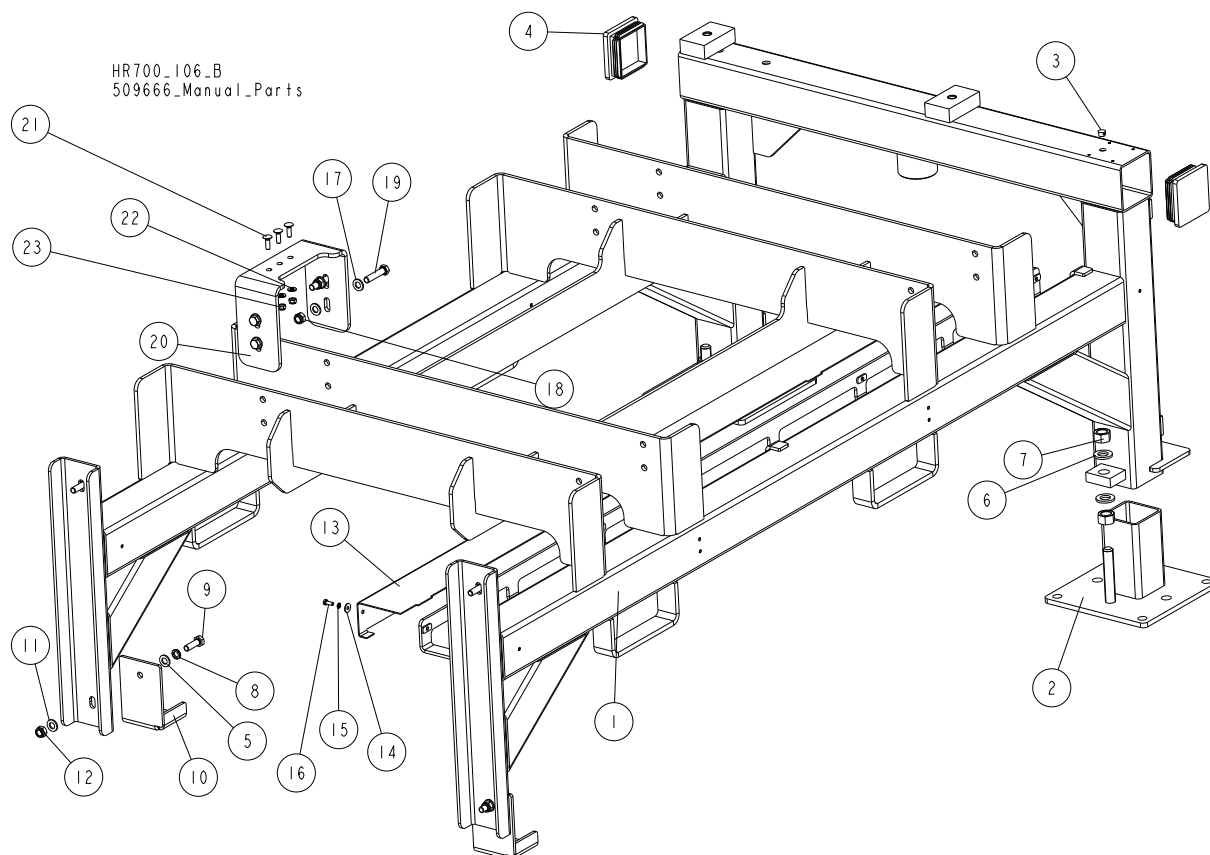

REF.	DESCRIPTION (◆ Indicates Parts Available In Assemblies Only)	PART #	QTY
	<b>BASE, HR700-2 ADDITIONAL MODULE - COMPLETE</b>	<b>509681</b>	<b>1</b>
1	BASE, HR700-2 ADDITIONAL MODULE	509682-1	1
2	FOOT, ADJUSTABLE LEG	099547-1	2
3	PLUG, 12.7 HOLE HEYMAN DP-812	086773	1
4	CAP, 100X100 #199200 SQUARE	090694	2
5	WASHER, 13 FLAT ZINC	F81056-1	4
6	WASHER, 21 FLAT ZINC	F81059-2	4
7	NUT, M20-8 HEX ZINC	F81037-1	4
8	WASHER, Z12.2 SPLIT LOCK ZINC	F81056-2	4
9	BOLT, M12X40-8.8 HEX HEAD FULL THREAD ZINC	F81004-4	4
	<b>BRACKET, HR700 FEED TRACK SUPPORT - COMPLETE</b>	<b>514728</b>	<b>2</b>
10	BRACKET, HR700 FEED TRACK SUPPORT	514726-1	1
11	WASHER, 13 FLAT ZINC	F81056-1	1
12	NUT, M12-8 HEX NYLON ZINC LOCK	F81034-2	1
	<b>COVER, CABLE/HOSE DUCT - COMPLETE</b>	<b>515182</b>	<b>1</b>
13	COVER, CABLE/HOSE DUCT	515183-1	1
14	WASHER, 6.5 SPECIAL FLAT ZINC	F81053-11	4
15	WASHER, Z6.1 SPLIT LOCK ZINC	F81053-3	4
16	BOLT, M6X16-8.8 HEX HEAD FULL THREAD ZINC	F81001-15	4



# REPLACEMENT PARTS

*Additional Module Feed Track, HR700*

1

REF.	DESCRIPTION (◆ Indicates Parts Available In Assemblies Only)	PART #	QTY
17	WASHER, 13 FLAT ZINC	F81056-1	8
18	NUT, M12-8 HEX NYLON ZINC LOCK	F81034-2	4
19	BOLT, M12X55-8.8 HEX HEAD ZINC	F81004-12	4
20	BRACKET, HR700 FEED TRACK SUPPORT	513495-1	1
21	BOLT, M8X25-8.8 CARRIAGE HEAD ZINC	F81002-59	3
22	WASHER, 8.4 FLAT ZINC	F81054-1	3
23	NUT, M8-8-B HEX NYLON ZINC LOCK	F81032-2	3

## 1.5 Additional Module Feed Track, HR700

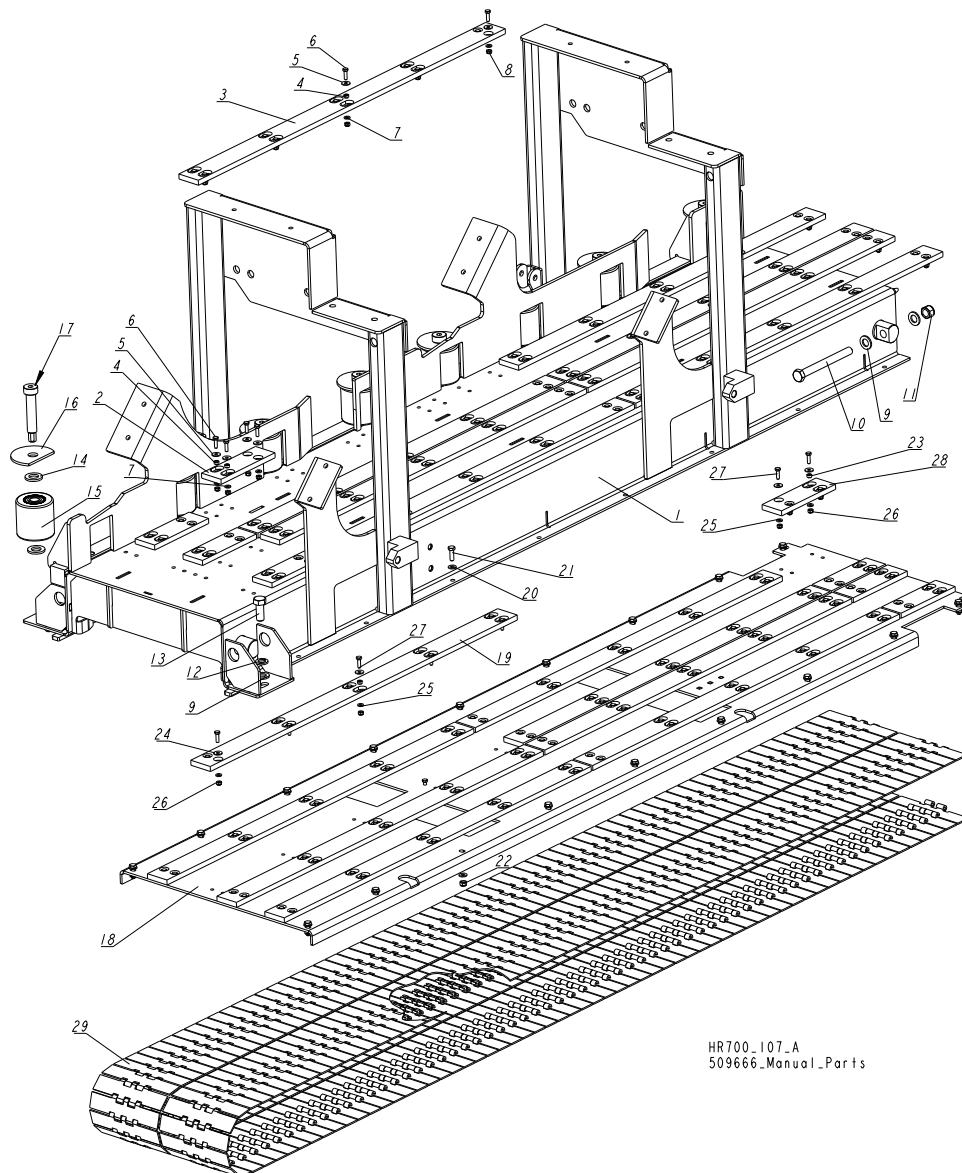

HR700\_107\_A  
509666\_Manual\_Parts

REF.	DESCRIPTION (◆ Indicates Parts Available In Assemblies Only)	PART #	QTY
	<b>TRACK, HR700 ADDITIONAL MODULE FEED - COMPLETE</b>	<b>509644</b>	<b>1</b>
1	TRACK, HR700-2 ADDITIONAL MODULE FEED	509645-1	1

# 1

## REPLACEMENT PARTS

*Additional Module Feed Track, HR700*

REF.	DESCRIPTION (◆ Indicates Parts Available In Assemblies Only)	PART #	QTY	
2	PAD, FEED TRACK PLASTIC - SHORT	099430	4	
3	PAD, FEED TRACK PLASTIC	092080	8	
4	BUSHING, 6.2X10X5 ZINC-PLATED SPACER	503674-1	72	
5	WASHER, 6.5 SPECIAL FLAT ZINC	F81053-11	96	
6	BOLT, M6X20 8.8 HEX HEAD FULL THREAD ZINC	F81001-2	96	
7	WASHER, 6.4 FLAT ZINC	F81053-1	96	
8	NUT, M6-8-B HEX NYLON ZINC LOCK	F81031-2	96	
9	WASHER, 17 SPLIT LOCK ZINC	F81058-1	6	
10	BOLT, M16X160 HEX HEAD ZINC	F81006-20	2	
11	NUT, M16-8 HEX NYLON ZINC LOCK	F81036-2	2	
12	WASHER, 16.3 SPLIT LOCK ZINC	F81058-2	2	
13	BOLT, M16X40-8.8 HEX HEAD FULL THREAD ZINC	F81006-13	2	
14	WASHER, 21 FLAT ZINC	F81059-2	16	
15	ROLLER, 80 R80-80-80 (ZABI) PLASTIC	099429	8	
16	PLATE, GUIDE ROLLER COVER ZINC-PLATED	099441-1	8	
17	BOLT, 20/M16X90 12.9 ISO7379 (BOSSARD) SHOULDER	F81006-30	8	
	<b>PLATE, LONG CHAIN SUPPORT - COMPLETE</b>	<b>509620</b>	<b>1</b>	
18	PLATE, LONG CHAIN SUPPORT	509622-1	1	
19	PAD, FEED TRACK PLASTIC	092080	8	
20	WASHER, 8.4 FLAT ZINC	F81054-1	36	
21	BOLT, M8X25-8.8-B HEX HEAD FULL THREAD ZINC	F81002-5	18	
22	NUT, M8 8 HEX NYLON ZINC LOCK	F81032-2	18	
23	BUSHING, 6.2X10X5 ZINC-PLATED SPACER	503674-1	72	
24	WASHER, 6.5 SPECIAL FLAT ZINC	F81053-11	96	
25	WASHER, 6.4 FLAT ZINC	F81053-1	96	
26	NUT, M6-8-B HEX NYLON ZINC LOCK	F81031-2	96	
27	BOLT, M6X20 8.8 HEX HEAD FULL THREAD ZINC	F81001-2	96	
28	PAD, FEED TRACK PLASTIC - SHORT	099430	4	
29	CHAIN, ACCATE S802 K750 7.94.110 (116-LINK)	099344	2	

**1.6 Feed Chain Drive Assembly, HR700**

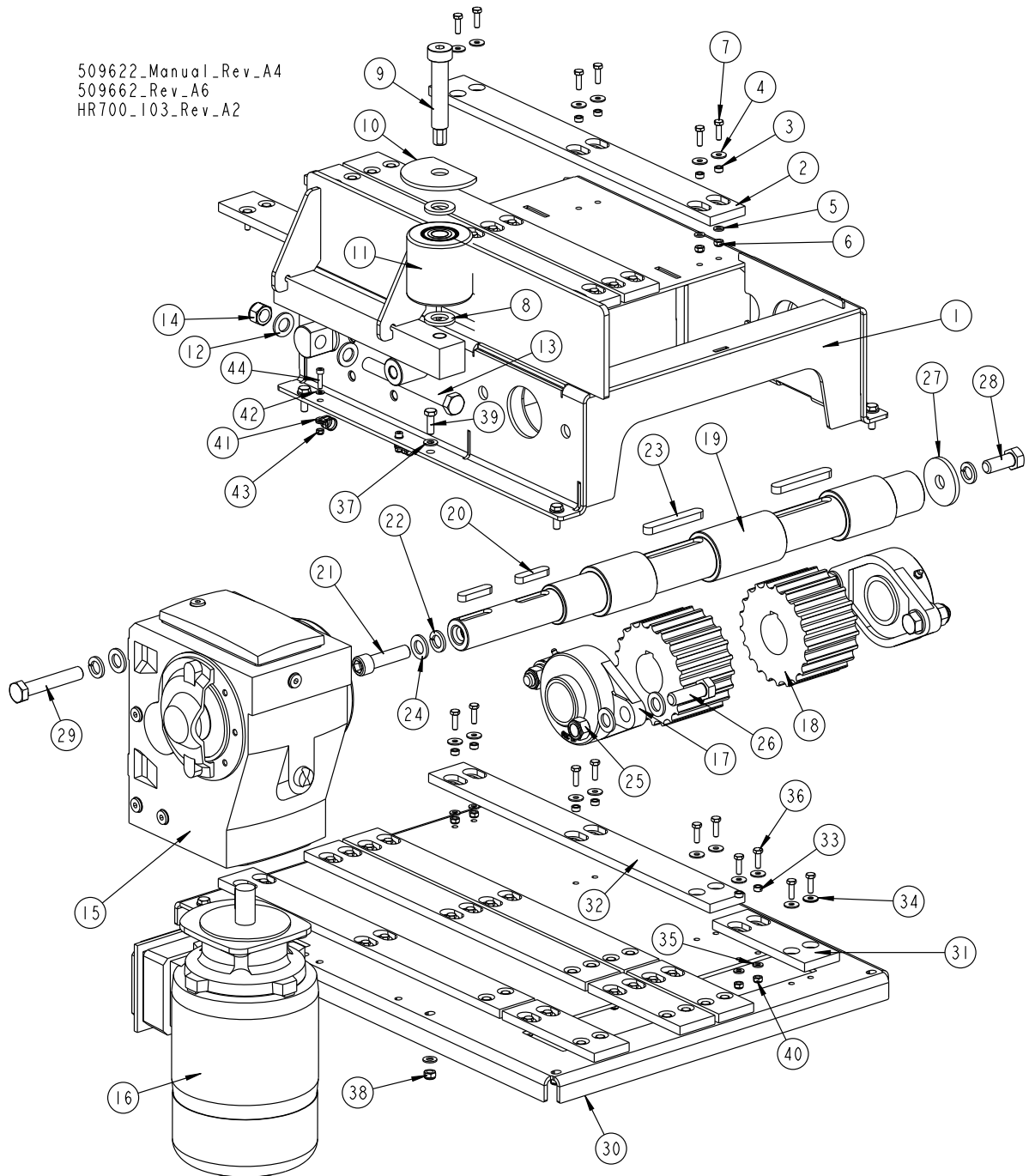

REF.	DESCRIPTION (◆ Indicates Parts Available In Assemblies Only)	PART #	QTY
	<b>DRIVE ASSEMBLY, HR700 FEED CHAIN</b>	<b>509611</b>	<b>1</b>
1	BRACKET, CHAIN DRIVE MOUNT	509612-1	1
2	PAD, FEED TRACK PLASTIC (MEDIUM)	099376	4

# 1

## REPLACEMENT PARTS

### Feed Chain Drive Assembly, HR700

REF.	DESCRIPTION (◆ Indicates Parts Available In Assemblies Only)	PART #	QTY
3	BUSHING, 6.2X10X5 ZINC-PLATED SPACER	503674-1	16
4	WASHER, 6.5 SPECIAL FLAT ZINC	F81053-11	24
5	WASHER, 6.4 FLAT ZINC	F81053-1	16
6	NUT, M6-8-B HEX NYLON ZINC LOCK	F81031-2	16
7	BOLT, M6X20 8.8 HEX HEAD FULL THREAD ZINC	F81001-2	24
8	WASHER, 21 FLAT ZINC	F81059-2	2
9	BOLT, 20/M16X90 12.9 ISO7379 (BOSSARD) SHOULDER	F81006-30	1
10	PLATE, GUIDE ROLLER COVER ZINC-PLATED	099441-1	1
11	ROLLER, 80 R80-80-80 (ZABI) PLASTIC	099429	1
12	WASHER, 17 SPLIT LOCK ZINC	F81058-1	4
13	BOLT, M16X160 HEX HEAD ZINC	F81006-20	2
14	NUT, M16-8 HEX NYLON ZINC LOCK	F81036-2	2
	<b>DRIVE ASSEMBLY, FEED CHAIN</b>	<b>509634</b>	<b>1</b>
	<b>MOTOREDUCER, SK9022.1AZDBH-90LH/4TF,I=49.01,M2,F3.0</b>	<b>509630</b>	<b>1</b>
15	REDUCER, SK9022.1AZBDH I=49.01 (NORD)	511846	1
16	MOTOR, SK 90LH/4 TF 1.5KW1400 (NORD)	511845	1
17	BEARING, UCFL210 W/HOUSING	098824	2
18	SPROCKET, KZN 800/21 A=80 B=50	099079	2
19	SHAFT, HR700 ZINC-PLATED DRIVE	509635-1	1
20	KEY, A12X8X50 DIN6885 PARALLEL	506735	2
21	SCREW, M16X60-8.8 HEX SOCKET HEAD CAP ZINC	F81006-19	1
22	WASHER, 16.3 SPLIT LOCK ZINC	F81058-2	3
23	KEY, A14X9X90 PARALLEL	099424	2
24	WASHER, 17 SPLIT LOCK ZINC	F81058-1	10
25	NUT, M16-8 HEX NYLON ZINC LOCK	F81036-2	4
26	BOLT, M16X50-8.8 HEX HEAD FULL THREAD ZINC	F81006-7	4
27	WASHER, 60X17.5X6 ZINC-PLATED CLAMPING	098012-1	1
28	BOLT, M16X40-8.8 HEX HEAD FULL THREAD ZINC	F81006-13	1
29	BOLT, M16X90-8.8 HEX HEAD ZINC	F81006-17	1
	<b>PLATE, FEED CHAIN SUPPORT - COMPLETE</b>	<b>509631</b>	<b>1</b>
30	PLATE, FEED CHAIN SUPPORT	511822-1	1
31	PAD, FEED TRACK PLASTIC (SHORT)	099430	4
32	PAD, FEED TRACK PLASTIC (MEDIUM)	099376	4
33	BUSHING, 6.2X10X5 ZINC-PLATED SPACER	503674-1	24
34	WASHER, 6.5 SPECIAL FLAT ZINC	F81053-11	40
35	WASHER, 6.4 FLAT ZINC	F81053-1	40
36	BOLT, M6X20 8.8 HEX HEAD FULL THREAD ZINC	F81001-2	40
37	WASHER, 8.4 FLAT ZINC	F81054-1	16
38	NUT, M8 8 HEX NYLON ZINC LOCK	F81032-2	8
39	BOLT, M8X25-8.8-B HEX HEAD FULL THREAD ZINC	F81002-5	8
40	NUT, M6-8-B HEX NYLON ZINC LOCK	F81031-2	40
41	CLAMP, RSGU 1.10/12W1 METAL & RUBBER	086861	2
42	WASHER, 5.3 FLAT ZINC	F81052-1	2
43	NUT, M5-8 DIN985 ZINC-PLATED	F81030-2	2
44	SCREW, M5X20 8.8 HEX SOCKET HEAD CAP ZINC	F81000-72	2

1.7 HR700 Hold-Down Rollers

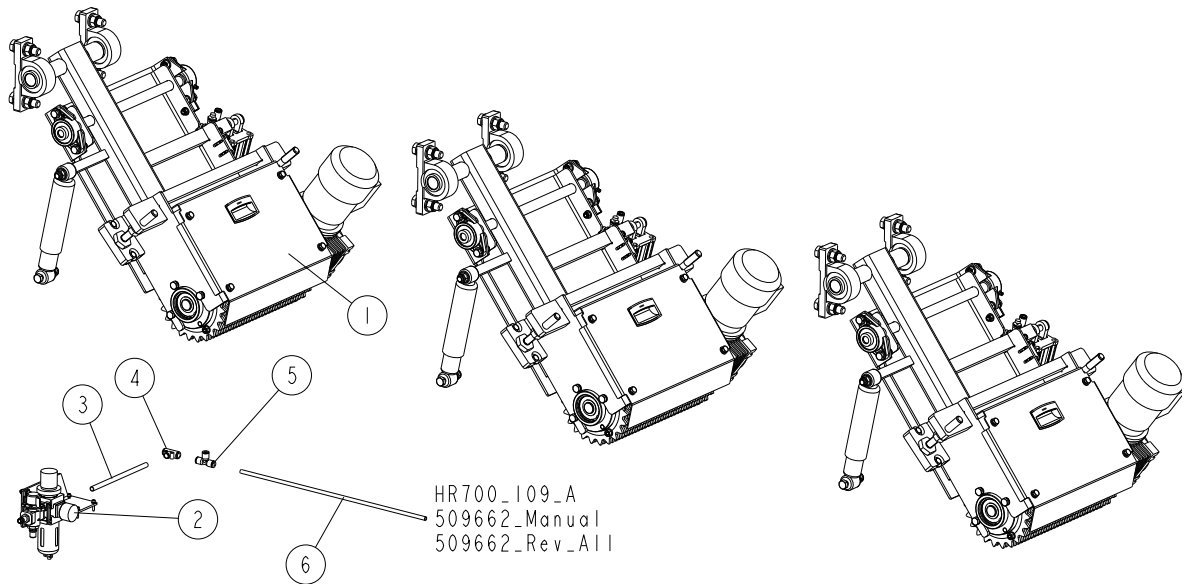

REF.	DESCRIPTION (◆ Indicates Parts Available In Assemblies Only)	PART #	QTY	QTY	QTY	QTY	QTY	QTY
	<b>HOLD-DOWN ROLLER KIT, HR700-1</b>	<b>511836</b>	2					
	<b>HOLD-DOWN ROLLER KIT, HR700-2</b>	<b>511837</b>		3				
	<b>HOLD-DOWN ROLLER KIT, HR700-3</b>	<b>511838</b>			4			
	<b>HOLD-DOWN ROLLER KIT, HR700-4</b>	<b>511839</b>				5		
	<b>HOLD-DOWN ROLLER KIT, HR700-5</b>	<b>511840</b>					6	
	<b>HOLD-DOWN ROLLER KIT, HR700-6</b>	<b>511841</b>						7
1	ROLLER, HR700 DRIVE - COMPLETE - <a href="#">See Section 1.9</a>	511895	2	3	4	5	6	7
2	AIR SUPPLY ASSEMBLY - <a href="#">See Section 1.8</a>	511847	1	1	1	1	1	1
3	HOSE, 10MM POLYURETHANE	096308	1	1	1	1	1	1
4	FITTING, TEE (SMC KQ2T08-10A)	514067	0	1	1	1	1	1
5	FITTING, T KQ2T08-00A TEE	090235	0	1	3	4	5	5
6	HOSE, 8MM POLYURETHANE HR700-1	515351	1	0	0	0	0	0
	HOSE, 8MM POLYURETHANE HR700-2	515352	0	1	0	0	0	0
	HOSE, 8MM POLYURETHANE HR700-3	515353	0	0	1	0	0	0
	HOSE, 8MM POLYURETHANE HR700-4	515354	0	0	0	1	0	0
	HOSE, 8MM POLYURETHANE HR700-5	515355	0	0	0	0	1	0
	HOSE, 8MM POLYURETHANE HR700-6	515356	0	0	0	0	0	1

# 1 REPLACEMENT PARTS

## Air Supply Assembly

### 1.8 Air Supply Assembly

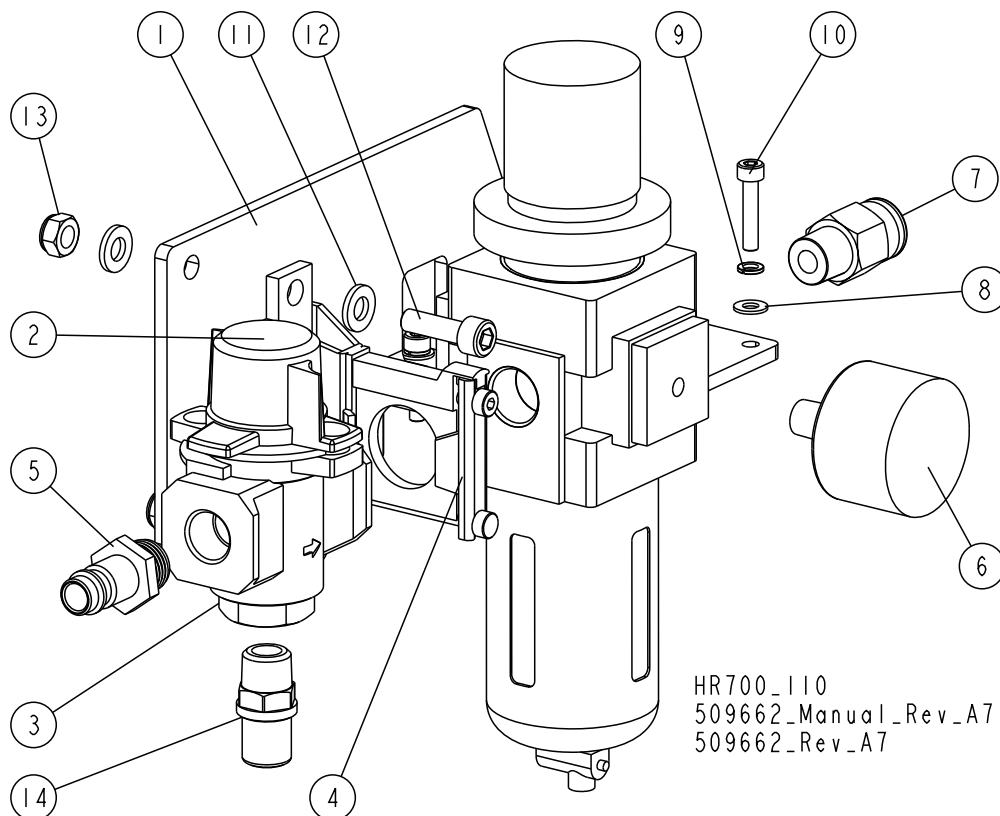

REF.	DESCRIPTION (◆ Indicates Parts Available In Assemblies Only)	PART #	QTY
	<b>AIR SUPPLY ASSEMBLY</b>	<b>511847</b>	<b>1</b>
1	PLATE, MOUNTING	511848-1	1
2	SPACER, Y300T W/BRACKET	510067	1
3	VALVE, VHS30-F02 SHUT-OFF	510068	1
4	REDUCER, AW30-F03H FILTER	510974	1
5	FITTING, GK 1381A GZ 1/4" MALE	510171	1
6	GAUGE, G36-10-01 (1/8") PRESSURE	510069	1
7	FITTING, (SMC KQ2H10-03) STRAIGHT MALE	510984	1
8	WASHER, 4.3 FLAT ZINC	F81051-2	4
9	WASHER, Z 4.1 SPLIT LOCK ZINC	F81051-1	4
10	SCREW, M4X20 8.8 HEX SOCKET HEAD CAP ZINC	F81011-31	4
11	WASHER, 6.4 FLAT ZINC	F81053-1	4
12	SCREW, M6X20 8.8 HEX SOCKET HEAD CAP ZINC	F81001-22	2
13	NUT, M6-8-B HEX NYLON ZINC LOCK	F81031-2	2
14	SILENCER, AN15-02 (1/4")	510073	1

### 1.9 Drive Roller, HR700

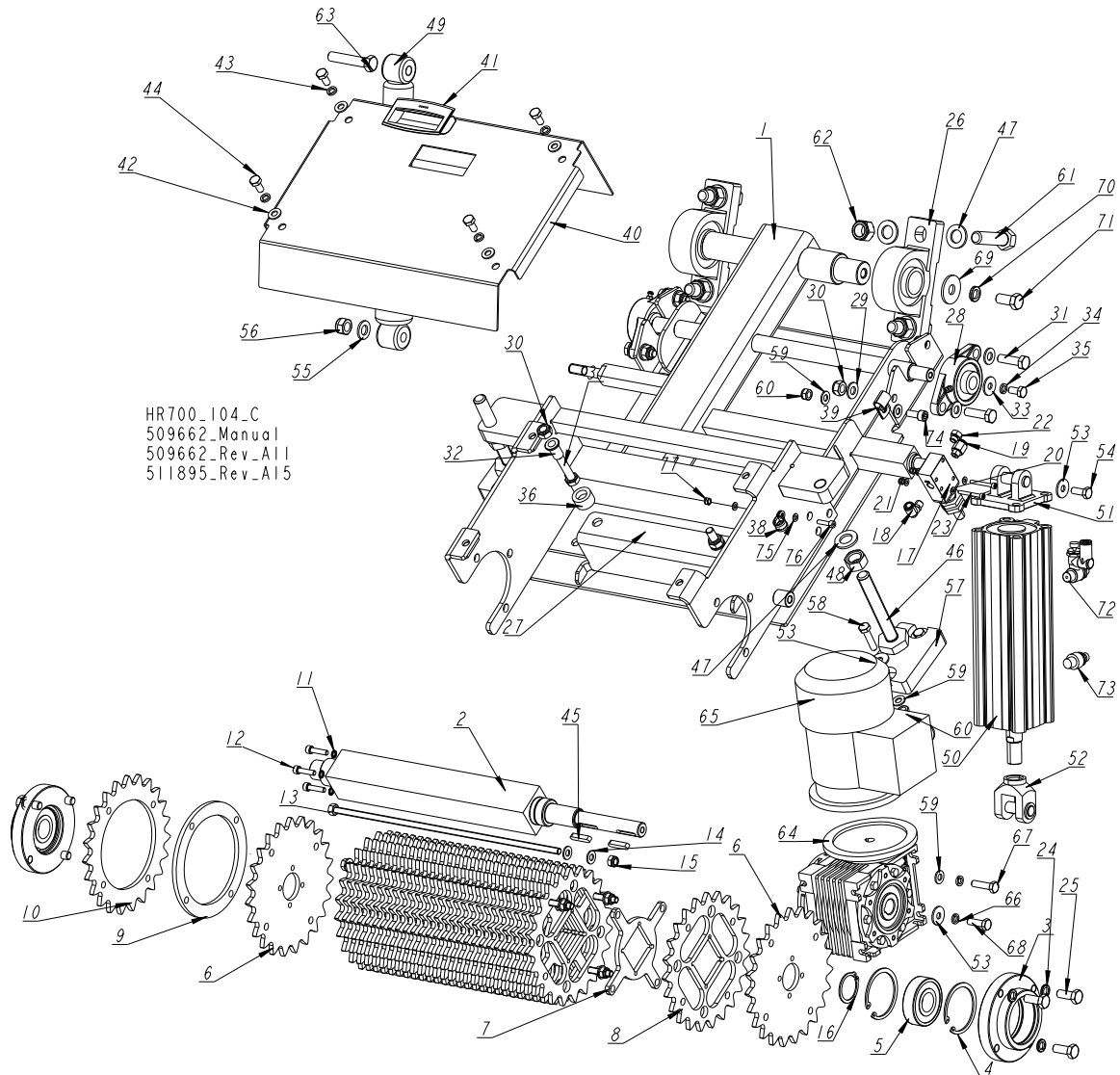

REF.	DESCRIPTION (◆ Indicates Parts Available In Assemblies Only)	PART #	QTY
	<b>ROLLER, HR700 DRIVE - COMPLETE</b>	<b>511895</b>	<b>1</b>
1	ARM WELDMENT, DRIVE HOLD-DOWN ROLLER	511890-1	1
	SHAFT ASSEMBLY, HR700 DRIVE	511885	1
2	SHAFT, HR700 ROLLER DRIVE	511884	1
	BEARING HOUSING, 6205 - COMPLETE	511883	2
3	HOUSING, 6205 BEARING	512144-1	1
4	RING, 62W INSIDE RETAINING	F81090-1	2
5	BEARING, 6305 2RS CX.	085706	1
6	PLATE, N160 OUTSIDE TOOTHED ZINC-PLATED	511887-1	2
	TOOTHED PLATE SET	511901	26

## 1

**REPLACEMENT PARTS***Drive Roller, HR700*

REF.	DESCRIPTION (◆ Indicates Parts Available In Assemblies Only)	PART #	QTY	
7	PLATE, SPACER	511888-1	1	
8	PLATE, N160 TOOTHED ZINC-PLATED CLAMPING	511886-1	1	
9	RING, OUTSIDE SPACER	511902-1	1	
10	PLATE, N160 DIA. OUTSIDE TOOTHED ZINC-PLATED	511903-1	1	
11	WASHER, Z 6.1 SPLIT LOCK ZINC	F81053-3	4	
12	SCREW, M6X25-8.8 HEX SOCKET HEAD CAP ZINC	F81001-41	4	
13	PIN, M8X360 ZINC-PLATED	511905-1	4	
14	WASHER, 8.4 FLAT ZINC	F81054-1	8	
15	NUT, M8 8 HEX NYLON ZINC LOCK	F81032-2	4	
16	RING, Z35 OUTSIDE RETAINING	F81090-36	1	
	MECHANICAL VALVE ASSEMBLY, AIR	511854	1	
17	MECHANICAL VALVE VM430-01-05, (1/8"), (SMC).	515251	1	
18	FITTING, KQ2L08-01AS (1/8") MALE ELBOW	511851	1	
19	FITTING, KQ2H08-01AS (1/8") STRAIGHT MALE	511850	1	
20	WASHER, 4.3 FLAT ZINC	F81051-2	4	
21	NUT, M4-8 HEX NYLON ZINC LOCK	F81029-1	2	
22	SILENCER, G1/8 AIR BRASS	502705	1	
23	SCREW, M4x35-8.8 HEX SOCKET HEAD CAP ZINC	F81011-34	2	
24	WASHER, Z 10.2 SPLIT LOCK ZINC	F81055-2	6	
25	BOLT, M10X25 8.8 HEX HEAD FULL THREAD	F81003-31	6	
26	HOUSING, UCP206 BEARING	099254	2	
	ACTIVATOR PLATE - COMPLETE	511853	1	
27	PLATE, ZINC-PLATED ACTIVATOR	511900-1	1	
28	BEARING, UCFL 203 (CX) W/HOUSING	507347	2	
29	WASHER, 10.5 FLAT ZINC	F81055-1	8	
30	NUT, M10-8-B HEX NYLON ZINC LOCK	F81033-1	6	
31	BOLT, M10X35 8.8 HEX HEAD FULL THREAD ZINC	F81003-17	4	
32	NUT, M10X13X22 ZINC-PLATED RIVET	F81033-15	2	
33	WASHER, ISO 7093-1-8-200 HV-A2E.	F81054-11	1	
34	WASHER, 8.2 SPLIT LOCK ZINC	F81054-4	1	
35	BOLT, M8X16-8.8-B HEX HEAD FULL THREAD ZINC	F81002-20	1	
36	BOOT, RUBBER BUMPER	089083	2	
37	BOLT, M10X45 HEX HEAD FULL THREAD ZINC	F81003-3	2	
38	CLAMP, RSGU 1.10/12W1 METAL & RUBBER	086861	2	
39	CLAMP, 1/2" EMT COATED	P07584	1	
	GUARD, DRIVE SHAFT - COMPLETE	511858	1	
40	GUARD, DRIVE SHAFT	511859-1	1	
41	HANDLE, EPR.90-PF-C1(261051-C1) SNAP-IN FLUSH PULL	100012	1	
42	WASHER, 8.4 FLAT ZINC	F81054-1	4	
43	WASHER, 8.2 SPLIT LOCK ZINC	F81054-4	4	
44	BOLT, M8X16-8.8-B HEX HEAD FULL THREAD ZINC	F81002-20	4	
45	KEY, A6X6X30 PARALLEL	094245	2	
46	BOLT, M16 ZINC-PLATED	100426-1	2	
47	WASHER, 17 SPLIT LOCK ZINC	F81058-1	10	
48	NUT, M16-8 HEX ZINC	F81036-1	2	



**REPLACEMENT PARTS***Drive Roller, HR700***1**

REF.	DESCRIPTION (◆ Indicates Parts Available In Assemblies Only)	PART #	QTY	
49	ABSORBER, WERTTEILE 554412 SHOCK	513494	1	
	CYLINDER, 63X200 AIR	508875_	1	
50	CYLINDER, CDQ2A63TF-200DCMZ AIR	508882	1	
51	BRACKET, CQ-D063 MOUNTING	508884	1	
52	JOINT, Y-G05 DOUBLE KNUCKLE	508883	1	
53	WASHER, ISO 7093-1-8-200 HV-A2E.	F81054-11	6	
54	BOLT, M8X20 5.8 HEX HEAD FULL THREAD ZINC	F81002-1	1	
55	WASHER, 13 FLAT ZINC	F81056-1	2	
56	NUT, M12-8 FE/ZN5 HEX NYLON ZINC LOCK	F81034-2	2	
57	BUMPER, GRENE 70 3201 0010 RUBBER	094969	2	
58	BOLT, M8X35-8.8 HEX HEAD FULL THREAD ZINC	F81002-13	4	
59	WASHER, 8.4 FLAT ZINC	F81054-1	5	
60	NUT, M8 8 HEX NYLON ZINC LOCK	F81032-2	4	
61	BOLT, M16X60-8.8 HEX HEAD FULL THREAD ZINC	F81006-12	4	
62	NUT, M16-8 HEX NYLON ZINC LOCK	F81036-2	4	
63	BOLT, M12X60-8.8 HEX HEAD FULL THREAD ZINC	F81004-51	1	
	MOTOREDUCER, MR40/51/0.12-1400/PS-N1/RR1/V5.	511889	1	
64	REDUCER, R-40/51/V5 W/TORQUE ARM	511907	1	
65	MOTOR, SKH 63-4A, 0.12 KW, 1400 R.P.M.	511908	1	
66	WASHER, 8.2 SPLIT LOCK ZINC	F81054-4	2	
67	BOLT, M8X30 8.8 HEX HEAD FULL THREAD ZINC	F81002-7	1	
68	BOLT, M8X25-8.8-B HEX HEAD FULL THREAD ZINC	F81002-5	1	
69	WASHER, 13 SPECIAL FLAT ZINC	F81056-14	1	
70	WASHER, Z12.2 SPLIT LOCK ZINC	F81056-2	1	
71	BOLT, M12X25-8.8 HEX HEAD FULL THREAD ZINC	F81004-31	1	
72	ASD430F-02-08S Valve, Throttle, non-return	514357	1	
73	ASN2-02-S Valve, Throttle with SilencerZ	514356	1	
74	SCREW, M8X20-8.8 HEX SOCKET HEAD CAP ZINC	F81002-30	1	
75	WASHER, 5.3 FLAT ZINC	F81052-1	1	
76	SCREW, M5X20 8.8 HEX SOCKET HEAD CAP ZINC	F81000-72	2	
77	NUT, M5-8-FE/ZN5 DIN985	F81030-2	2	

# 1

## REPLACEMENT PARTS

Hold-Down Roller, 126 (Optional)

### 1.10 Hold-Down Roller, 126 (Optional)

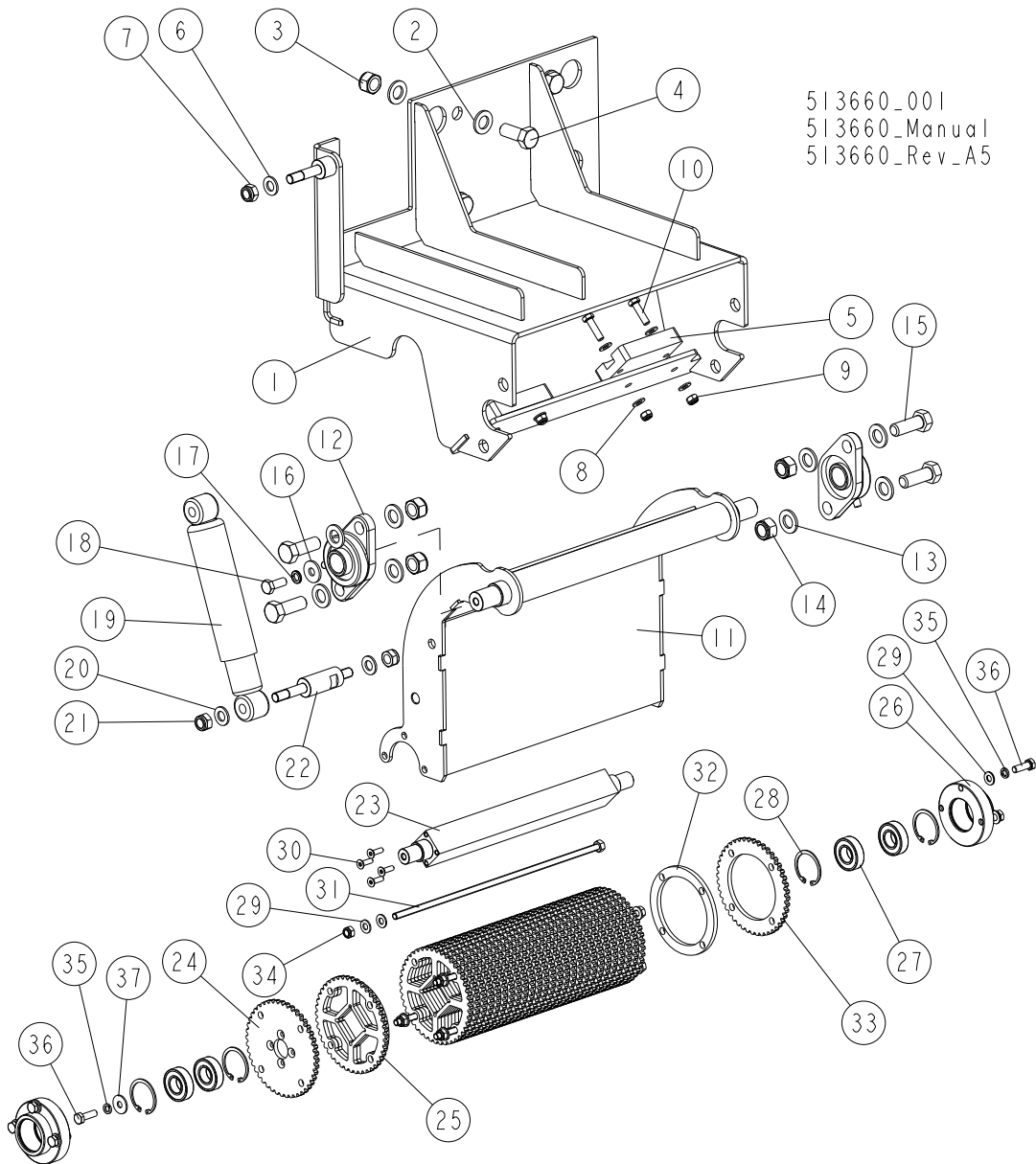

REF.	DESCRIPTION (◆ Indicates Parts Available In Assemblies Only)	PART #	QTY
	<b>ROLLER, N126, HR700,KPL.ADDITIONAL HOLD-DOWN - COMPLETE</b>	<b>513660</b>	<b>1</b>
	<b>MOUNT WELDMENT, ADDITIONAL HOLD-DOWN ROLLER - COMPLETE</b>	<b>513663</b>	<b>1</b>
1	MOUNT WELDMENT, ADDITIONAL HOLD-DOWN ROLLER	513651-1	1
2	WASHER, 17 SPLIT LOCK ZINC	F81058-1	8
3	NUT, M16-8 HEX NYLON ZINC LOCK	F81036-2	4
4	BOLT, M16X40-8.8 HEX HEAD FULL THREAD ZINC	F81006-13	4
5	BUMPER, GRENE 70 3201 0010 RUBBER	094969	2
6	WASHER, 13 FLAT ZINC	F81056-1	1
7	NUT, M12-8 HEX NYLON ZINC LOCK	F81034-2	1
8	WASHER, 8.4 FLAT ZINC	F81054-1	8

# REPLACEMENT PARTS

*Hold-Down Roller, 126 (Optional)*

1

REF.	DESCRIPTION (◆ Indicates Parts Available In Assemblies Only)	PART #	QTY
9	NUT, M8-8-B HEX NYLON ZINC LOCK	F81032-2	4
10	BOLT, M8X30 8.8 HEX HEAD FULL THREAD ZINC	F81002-7	4
	<b>ARM, ADDITIONAL HOLD-DOWN ROLLER - COMPLETE</b>	<b>513662</b>	<b>1</b>
11	ARM, ADDITIONAL HOLD-DOWN ROLLER	513661-1	1
12	BEARING, UCFL205 W/HOUSING (COMPLEX)	089124	2
13	WASHER, 17 SPLIT LOCK ZINC	F81058-1	8
14	NUT, M16-8 HEX NYLON ZINC LOCK	F81036-2	4
15	BOLT, M16X45-8.8 HEX HEAD FULL THREAD ZINC	F81006-46	4
16	WASHER, 10.5 SPECIAL FLAT ZINC	F81055-6	1
17	WASHER, Z10.2 SPLIT LOCK ZINC	F81055-2	1
18	BOLT, M10X25 8.8 HEX HEAD FULL THREAD ZINC	F81003-11	1
19	ABSORBER, WERTTEILE 554412 SHOCK	513494	1
20	WASHER, 13 FLAT ZINC	F81056-1	2
21	NUT, M12-8 HEX NYLON ZINC LOCK	F81034-2	2
22	PIN, SHOCK ABSORBER MOUNT ZINC-PLATED	513657-1	1
	<b>ROLLER, N126 HOLD-DOWN - COMPLETE</b>	<b>513650</b>	<b>1</b>
23	SHAFT, ADDITIONAL HOLD-DOWN ROLLER ZINC-PLATED	513649-1	1
24	WHEEL, N126 TOOTHED ZINC-PLATED LOCKING	513664-1	2
25	WHEEL, TOOTHED INSIDE - COMPLETE	514223	26
	<b>HOUSING W/BEARINGS, 6004 2RS - COMPLETE</b>	<b>514225</b>	<b>2</b>
26	HOUSING, 6004 2RS BEARING ZINC-PLATED	514226-1	1
27	BEARING, 6004 2RS CX ROLLING	093868	2
28	RING, SEG W042 INSIDE RETAINING	F81090-19	2
29	WASHER, 8.4 FLAT ZINC	F81054-1	14
30	SCREW, M6X20-10.9 FE/ZN5 DIN7991 FLAT SOCKET HEAD CAP	F81001-17	8
31	PIN, M8X360 ZINC-PLATED	511905-1	4
32	RING, OUTSIDE ZINC-PLATED SPACER	513666-1	1
33	RING, TOOTHED ZINC-PLATED LOCKING	514224-1	1
34	NUT, M8-8-B HEX NYLON ZINC LOCK	F81032-2	4
35	WASHER, 8.2 SPLIT LOCK ZINC	F81054-4	7
36	BOLT, M8X25-8.8-B HEX HEAD FULL THREAD ZINC	F81002-5	7
37	WASHER, ISO 7093-1-8-200 HV-A2E	F81054-11	1

# 1 REPLACEMENT PARTS

*Up/Down System, HR700*

## 1.11 Up/Down System, HR700

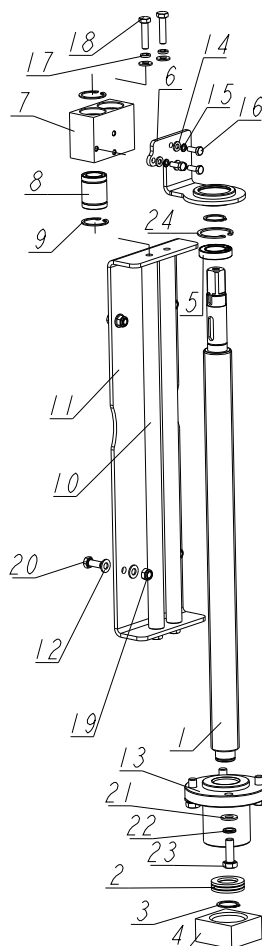

HR700\_108\_A  
509666\_Manual\_Parts  
509666\_Rev\_A10

REF.	DESCRIPTION (◆ Indicates Parts Available In Assemblies Only)	PART #	QTY
	SAW HEAD HEIGHT ADJUSTMENT KIT - 1-HEAD	511823	1/0/0/0/0/0
	SAW HEAD HEIGHT ADJUSTMENT KIT - 2-HEAD	511824	0/1/0/0/0/0
	SAW HEAD HEIGHT ADJUSTMENT KIT - 3-HEAD	511825	0/0/1/0/0/0
	SAW HEAD HEIGHT ADJUSTMENT KIT - 4-HEAD	511826	0/0/0/1/0/0
	SAW HEAD HEIGHT ADJUSTMENT KIT - 5-HEAD	511827	0/0/0/0/1/0
	SAW HEAD HEIGHT ADJUSTMENT KIT - 6-HEAD	511828	0/0/0/0/0/1
	SAW HEAD HEIGHT ADJUSTMENT ASSEMBLY, SHS/HR700 - MANUAL	506778	1/2/3/4/5/6
	RATCHET, 3/4" 645300 HEYCO PUSH-THROUGH	507312	1

# REPLACEMENT PARTS

Up/Down System, HR700

1

REF.	DESCRIPTION (◆ Indicates Parts Available In Assemblies Only)	PART #	QTY.	
	<b>SAW HEAD HEIGHT ADJUSTMENT ASSEMBLY, SHS/HR700 - MANUAL</b>	<b>506778</b>	<b>1</b>	
1	SCREW, TR36X3 ACME ZINC-PLATED	506779-1	1	
2	BEARING, 51105 THRUST	088033	1	
3	RING, 25Z OUTSIDE RETAINING	F81090-22	2	
4	BLOCK, ACME SCREW ZINC-PLATED MOUNT	093265-1	1	
5	BEARING, 61905 2RS (COMPLEX)	099037	1	
6	BRACKET, ZINC-PLATED RETAINING	507309-1	1	
	BLOCK, LASER MOUNT - COMPLETE	504010	1	
7	BLOCK, LM 20 UU LINEAR BEARING HOUSING ZINC-PL.	504011-1	1	
8	BEARING, LM 20 UU LINEAR MOTION	504012	2	
9	RING, 32W INSIDE RETAINING	F81090-5	4	
10	ROD, LASER GUIDE (CHROMIUM-PLATED)	504359	2	
11	BRACKET, GUIDE ROD MOUNT	507308-1	1	
12	WASHER, 8.4 FLAT ZINC	F81054-1	12	
13	NUT, TR36X3 ACME SCREW	506780	1	
14	WASHER, 6.4 FLAT ZINC	F81053-1	3	
15	WASHER, Z 6.1 SPLIT LOCK ZINC	F81053-3	3	
16	BOLT, M6X16 8.8 HEX HEAD FULL THREAD ZINC	F81001-32	3	
17	WASHER, 8.2 SPLIT LOCK ZINC	F81054-4	4	
18	BOLT, M8X35-8.8 HEX HEAD FULL THREAD ZINC	F81002-13	4	
19	NUT, M8 8 HEX NYLON ZINC LOCK	F81032-2	4	
20	BOLT, M8X20 8.8 HEX HEAD FULL THREAD ZINC	F81002-4	4	
21	WASHER, 10.5 FLAT ZINC	F81055-1	4	
22	WASHER, Z10.2 SPLIT LOCK ZINC	F81055-2	4	
23	BOLT, M10X30 5.8 HEX HEAD FULL THREAD ZINC	F81003-2	4	
24	RING, SEG W042 RETAINING	F81090-19	1	

# 1 REPLACEMENT PARTS

## Blade Guide Assembly, Idle Side

### 1.12 Blade Guide Assembly, Idle Side

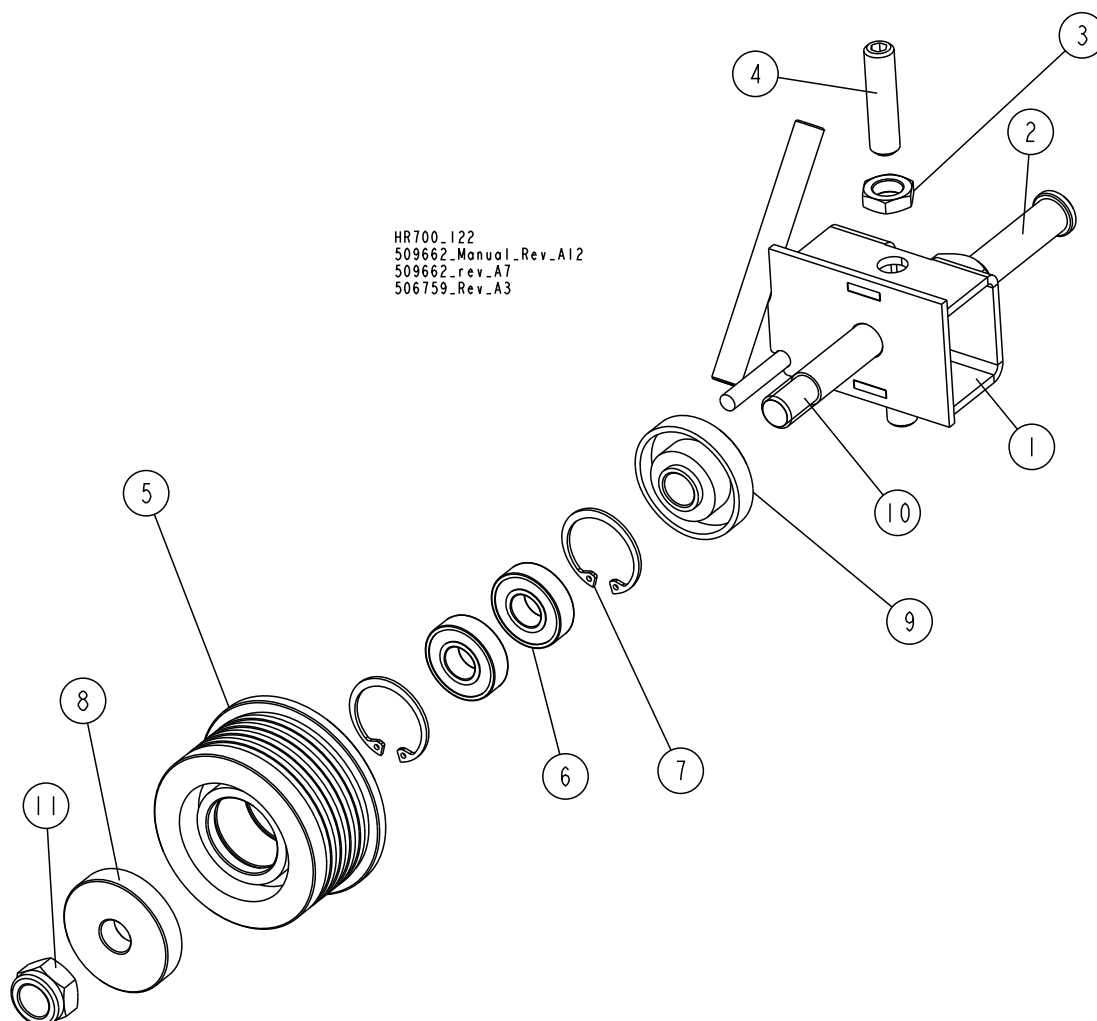

REF.	DESCRIPTION (◆ Indicates Parts Available In Assemblies Only)	PART #	QTY
	<b>BLADE GUIDE W/EXTENDED ROLLER - IDLE SIDE</b>	<b>506759</b>	<b>1</b>
1	BRACKET WELDMENT, IS BLADE GUIDE ZINC-PLATED	500497-1	1
2	SHAFT, BLADE GUIDE MOUNT ZINC-PLATED	088255-1	1
3	NUT, M10X1-04-ST-A2E ISO8675 THIN	F81033-10	2
4	SCREW, M10X1X40 DIN913 A2-70 STAINLESS STEEL SET	F81015-2	2
	ROLLER ASSEMBLY, BLADE GUIDE W/BEARINGS	500561	1
5	ROLLER, EXTENDED BLADE GUIDE	500560	1
6	BEARING, 6001 2RSR (FAG, SKF)	087893	2
7	RING, W28 WG INSIDE RETAINING	F81090-9	2
8	RING, ZINC-PLATED SPACER	087891-1	1
9	RING, ZINC-PLATED SPACER (EXTENDED BLADE GUIDE ROLLER)	087892-1	1
10	SHAFT, EXTENDED ROLLER ZINC-PLATED	087762-1	1
11	NUT, M12-8 HEX NYLON ZINC LOCK	F81034-2	1

**1.13 Blade Guide Assembly, Drive Side**

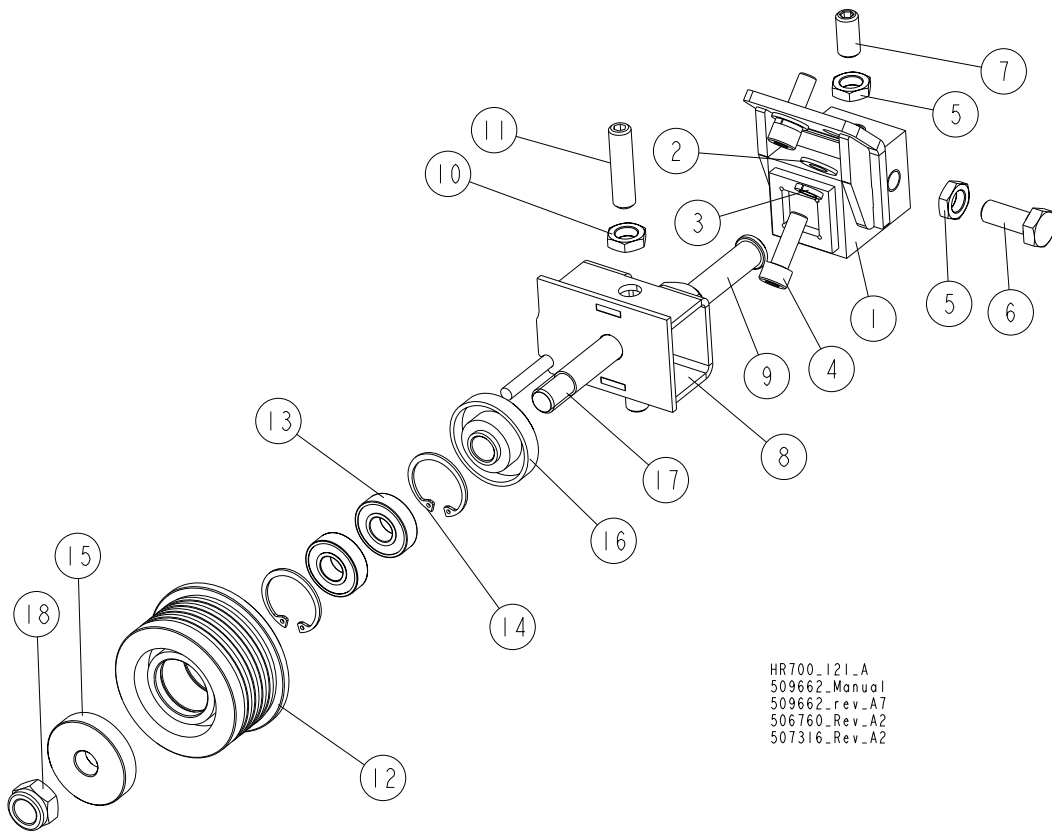

HR700\_121\_A  
509662\_Manual  
509662\_rev\_A7  
506760\_Rev\_A2  
507316\_Rev\_A2

REF.	DESCRIPTION (◆ Indicates Parts Available In Assemblies Only)	PART #	QTY
	<b>BLOCK, BLADE GUIDE MOUNT - COMPLETE</b>	<b>507316</b>	<b>1</b>
1	BLOCK WELDMENT, BLADE GUIDE MOUNT	514887-1	1
2	WASHER, 8.4 FLAT,ZINC	F81054-1	2
3	WASHER, 8.2 SPLIT LOCK ZINC	F81054-4	2
4	SCREW,M8x25-8.8 HEX SOCKET HEAD CAP ZINC	F81002-21	2
5	NUT, M10X1-04-ST-A2E ISO8675 THIN	F81033-10	4
6	BOLT, M10X1X25 DIN 933 STAINLESS STEEL	F81003-28	1
7	SCREW, M10X1X20 DIN 913 STAINLESS STEEL SET	F81015-1	3
	<b>BLADE GUIDE W/EXTENDED ROLLER - DRIVE SIDE</b>	<b>506760</b>	<b>1</b>
8	BRACKET WELDMENT, DRIVE SIDE BLADE GUIDE ROLLER	500498-1	1
9	SHAFT, BLADE GUIDE MOUNT ZINC-PLATED	088255-1	1
10	NUT, M10X1-04-ST-A2E ISO8675 THIN	F81033-10	2
11	SCREW, M10X1X40 DIN913 A2-70 STAINLESS STEEL SET	F81015-2	2
	<b>ROLLER ASSEMBLY, BLADE GUIDE W/BEARINGS</b>	<b>500561</b>	<b>1</b>
12	ROLLER, EXTENDED BLADE GUIDE	500560	1
13	BEARING, 6001 2RSR (FAG, SKF)	087893	2
14	RING, W28 INSIDE RETAINING	F81090-9	2
15	RING, ZINC-PLATED SPACER	087891-1	1
16	RING, ZINC-PLATED SPACER (EXTENDED BLADE GUIDE ROLLER)	087892-1	1
17	SHAFT, EXTENDED ROLLER ZINC-PLATED	087762-1	1
18	NUT, M12-8 HEX NYLON ZINC LOCK	F81034-2	1



# REPLACEMENT PARTS

## Blade Wheel Assembly, Drive Side

### 1.14 Blade Wheel Assembly, Drive Side

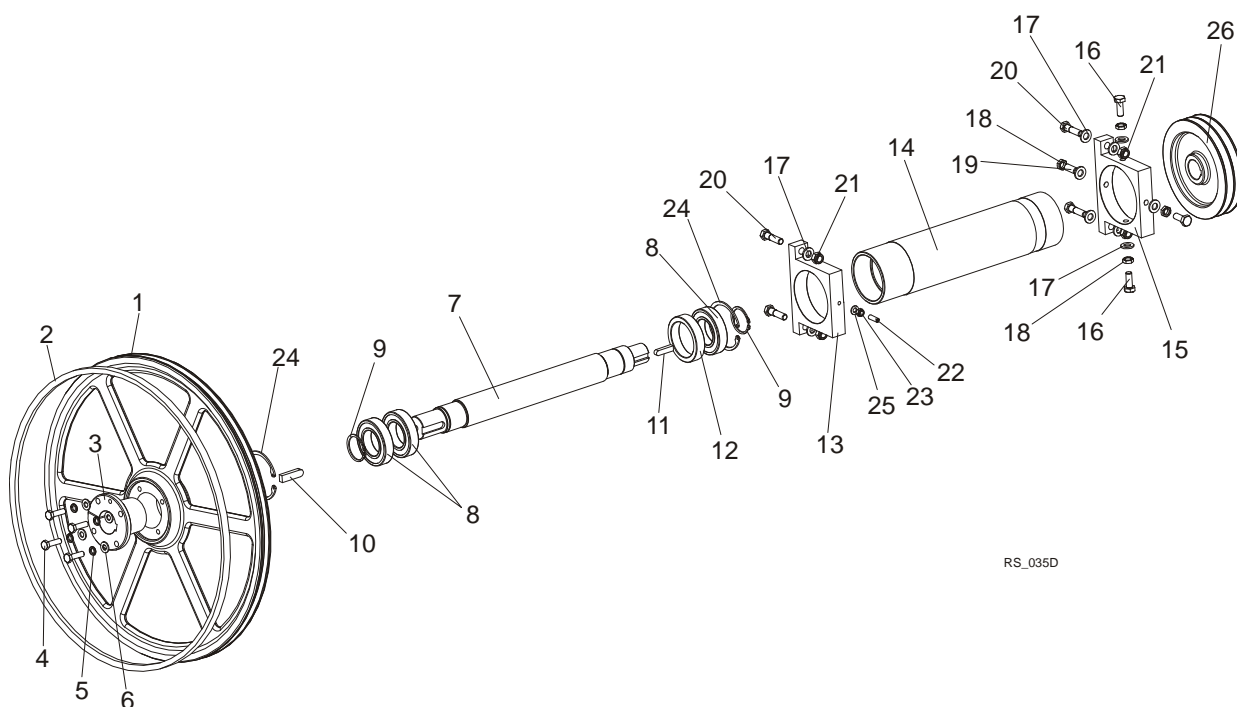

REF.	DESCRIPTION (◆ Indicates Parts Available In Assemblies Only)	PART #	QTY
1	<b>WHEEL, DRIVE SIDE BLADE</b>	500100-1	1
2	<b>V-BELT, B72.5</b>	017922-1	1
3	<b>BUSHING, 45 SPLIT TAPER</b>	500099	1
4	<b>BOLT, M10X35 8.8 HEX HEAD FULL THREAD ZINC</b>	F81003-17	4
5	<b>WASHER, 10.2 SPLIT LOCK ZINC</b>	F81055-2	4
6	<b>WASHER, 10.5 FLAT ZINC</b>	F81055-1	4
	<b>SHAFT, DRIVE SIDE BLADE WHEEL - COMPLETE</b>	093239	1
7	Shaft, Drive Side Blade Wheel	093238	1
8	Bearing, 6210 2RSR	093237	3
9	Ring, Z50 Outside Retaining	F81090-28	2
10	Key, AB 14x9x50 Parallel	093266	1
11	Key, AB 10x8x40 Parallel	091990	1
12	Spacer, Blade Wheel Shaft	094439	1
13	Bracket, Drive Shaft Adjustment Zinc-Plated	093255-1	1
14	Bushing, Drive Shaft Housing	093234-1	1
15	Bracket, Drive Shaft Bushing Mount Zinc-Plated	094535-1	1
16	Bolt, M12x1.25x30 DIN933 A2-70 Stainless Steel	F81004-44	3
17	Washer, 13 Flat Zinc	F81056-1	4
18	Nut, M12x1.25 DIN439 Stainless Steel Thin	F81034-9	4
19	Screw, M12x1.25x30 DIN913 Stainless Steel Set	F81016-1	1
20	Bolt, M12x45-8.8 Hex Head Zinc	F81004-32	4
21	Nut, M12-8 Hex Nylon Zinc Lock	F81034-2	4



# REPLACEMENT PARTS

## Blade Wheel Assembly, Idle Side

1

22	Screw, M8x25 A2-70 DIN 913 Stainless Steel Set	F81014-3	1	
23	Nut, M8-8-B Hex Nylon Zinc Lock	F81032-2	1	
24	Ring, W90 Inside Retaining	F81090-29	2	
25	Washer, 8.4 Flat Zinc	F81054-1	1	
26	PULLEY, SPB $\Phi 224 \times 2 / \Phi 38$ (F02312+T31124)	500177	1	
	PULLEY, SPB $\Phi 190 \times 2 / \Phi 38$ (F02347+T31124)	500569	1	

### 1.15 Blade Wheel Assembly, Idle Side

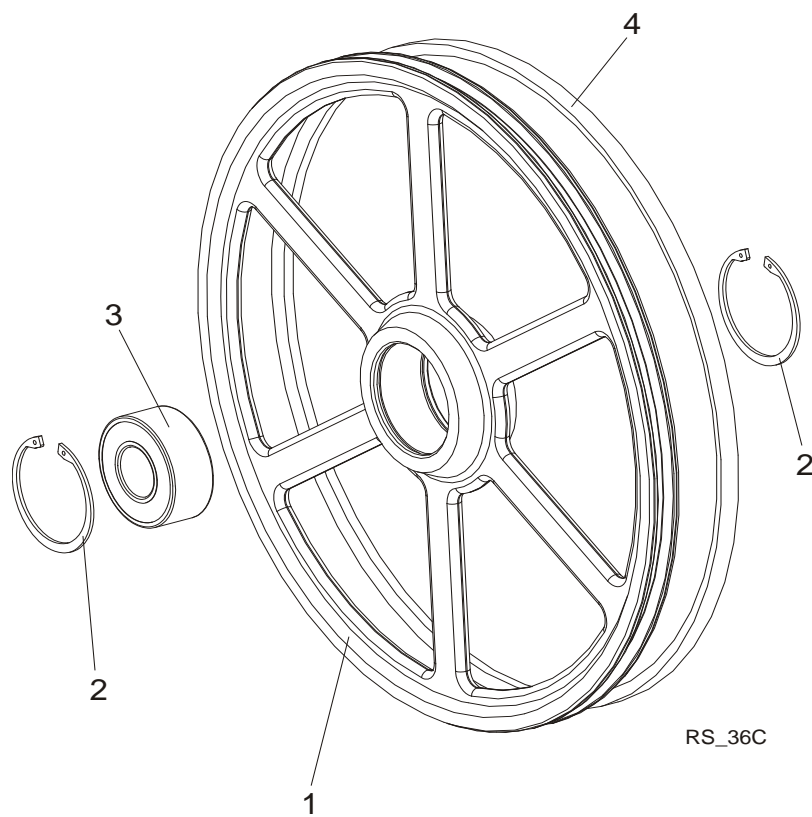

REF.	DESCRIPTION (◆ Indicates Parts Available In Assemblies Only)	PART #	QTY	
	<b>WHEEL, IDLE SIDE BLADE - COMPLETE</b>	<b>088764</b>	1	
1	Wheel, Idle Side Blade	090810	1	
2	Ring, W100 Inside Retaining	F81090-10	2	
3	Bearing, 3309B.2RSR.TVH FAG	086428	1	
4	<b>V-BELT, B72.5</b>	017922-1	1	

# 1

## REPLACEMENT PARTS

### Hydraulic Blade Tensioner Assembly

#### 1.16 Hydraulic Blade Tensioner Assembly

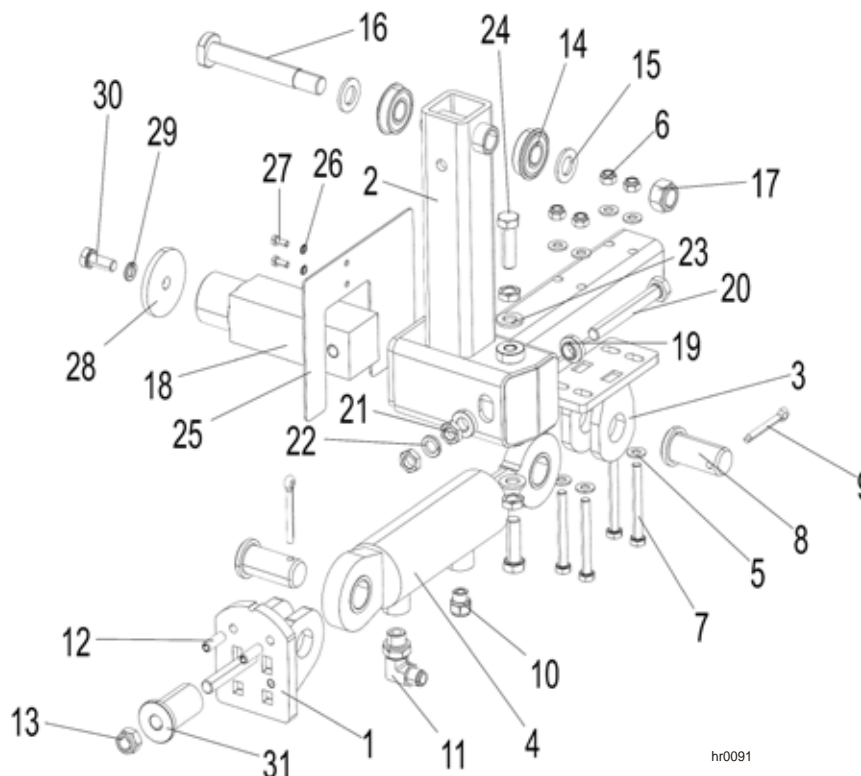

REF.	DESCRIPTION (◆ Indicates Parts Available In Assemblies Only)	PART #	QTY
	<b>HR/SHS HYDRAULIC BLADE TENSIONER - COMPLETE</b>	<b>506750</b>	<b>1</b>
1	BRACKET, PISTON CYLINDER MOUNT	506751-1	1
2	ARM WELDMENT, TVS IDLE BLADE WHEEL (RIGHT-SIDE SAW HEAD)	504817-1	1
3	BRACKET, PISTON CYLINDER UPPER MOUNT	504819-1	1
4	CYLINDER, SJ2F-16-50/28/70 PISTON	504812	1
5	WASHER, 8.4 FLAT ZINC	F81054-1	8
6	NUT, M8 8 HEX NYLON ZINC LOCK	F81032-2	4
7	BOLT, M8x70-8.8 HEX HEAD ZINC	F81002-71	4
8	PIN	504824-1	2
9	PIN, S-Zn-6.3x45 COTTER	F81045-2	2
10	SILENCER, TYPE 2901-14-17	090794	1
11	FITTING, 90° - 3/8 BSP - 9/16 JIC ELBOW	096335	1
12	PIN, 8x26 ZINC ROLL	F81046-4	2
13	NUT, M12 8 HEX NYLON ZINC LOCK	F81034-2	1
14	BEARING, 6203-2RS NR. W/SNAP RING	086395	2
15	WASHER, 17 SPLIT LOCK ZINC	F81058-1	2
16	BOLT, ARM BEARING MOUNT	086404	1
17	NUT, M16-8 HEX NYLON ZINC LOCK	F81036-2	1
18	SHAFT, IDLE-SIDE BLADE WHEEL	088474	1
19	WASHER, FLANGED ZINC-PLATED	086769-1	2
20	BOLT, M12x1.25x100-8.8 HEX HEAD FULL THREAD ZINC	F81004-41	1

# REPLACEMENT PARTS

*Hydraulic Blade Tensioner Assembly*

1

21	NUT, M12X1.25-8 ZINC THIN	F81034-5	4	
22	WASHER, Z12.2 SPLIT LOCK ZINC	F81056-2	1	
23	WASHER, 13 FLAT ZINC	F81056-1	2	
24	BOLT, M12x1.25x40-8.8 HEX HEAD FULL THREAD ZINC	F81004-42	2	
25	GUARD, IDLE BLADE WHEEL ARM	088442-1	1	
26	WASHER, 5.1 SPLIT LOCK	F81052-2	2	
27	BOLT, M5X12 5.8 HEX HEAD FULL THREAD ZINC	F81000-5	2	
28	WASHER, IDLE BLADE WHEEL RETAINING	088957-1	1	
29	WASHER, Z 10.2 SPLIT LOCK ZINC	F81055-2	1	
30	BOLT, M10X25 8.8 HEX HEAD FULL THREAD	F81003-31	1	
31	BUSHING, 28.5 TO 13 ZINC-PLATED REDUCER	508708-1	1	

# 1 REPLACEMENT PARTS

## Hydraulic Blade Tensioner

### 1.17 Hydraulic Blade Tensioner

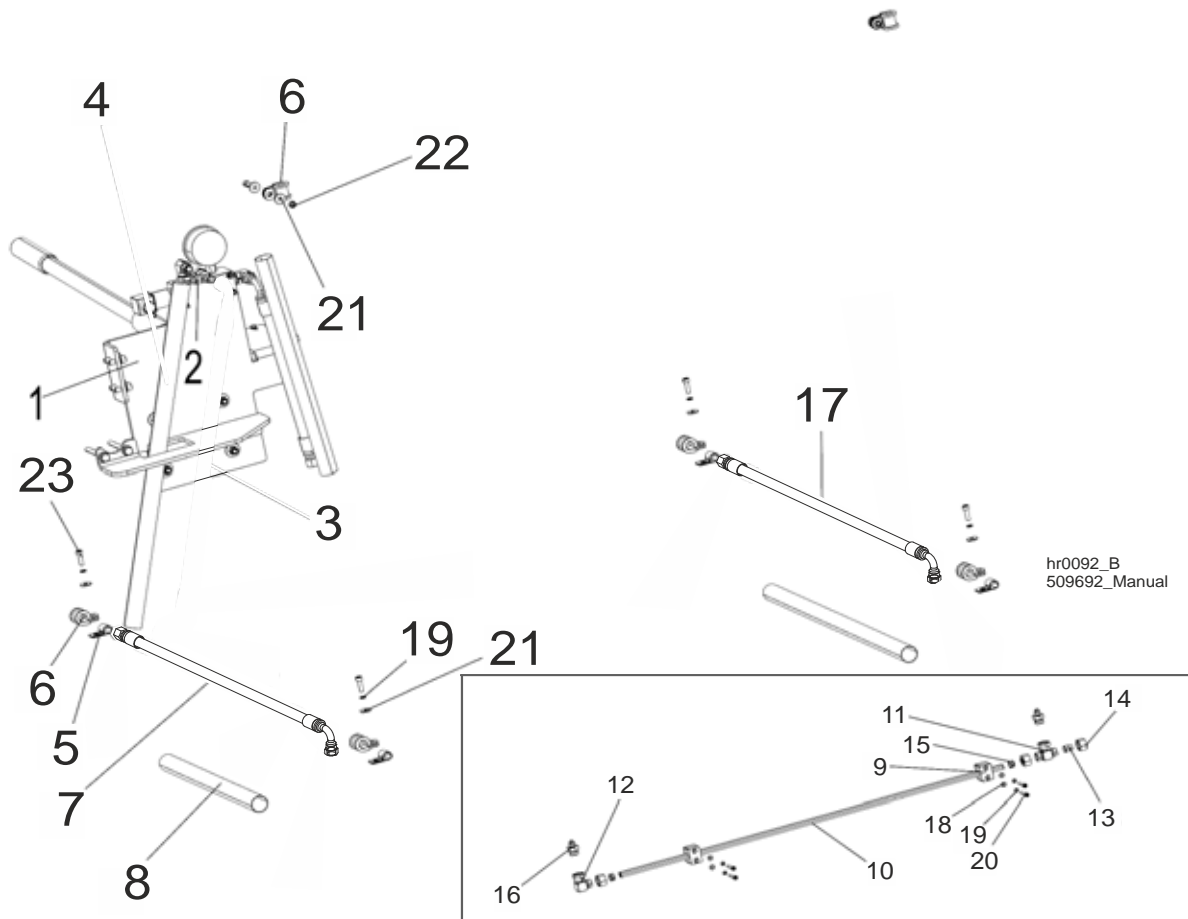

REF.	DESCRIPTION (◆ Indicates Parts Available In Assemblies Only)	PART #	QTY
	<b>HYDRAULIC BLADE TENSIONER FOR HR700-1 - COMPLETE</b>	<b>511863</b>	<b>1</b>
	HYDRAULIC PUMP ASSEMBLY, SHS/HR500/HR700	506733	1
	HOSE, PHD 2T3/8x0.43 90W9/16UNF-90W9/16UNF HYDRAULIC	506737	1
	GUARD, OBLIQUE HOSE	508714	1
	<b>HYDRAULIC BLADE TENSIONER FOR HR700-2 - COMPLETE</b>	<b>511864</b>	<b>1</b>
1	HYDRAULIC PUMP ASSEMBLY, SHS/HR500/HR700	506733 <sup>1</sup>	1
2	FITTING, BBA UNF 9/16" TEE W/NUT	509687	1
3	HOSE, PHD 2T3/8x0.43 90W9/16UNF-90W9/16UNF HYDRAULIC	506737	1
4	GUARD, OBLIQUE HOSE	508714	2
5	CLAMP, 1/2" EMT COATED	P07584	4
6	CLAMP, RSGU 1.15/20 METAL & RUBBER	509701	6
7	HOSE, PHD 2T3/8x2.85 90W9/16UNF-W9/16UNF HYDRAULIC	509718	1
8	GUARD, VERTICAL HOSE	508713	1
9	BLOCK, DN15 APP-L-15 PIPE BRACKET	509720	2
10	PIPE, L=1050	509699	1
11	FITTING, XEVT 15 L 22x1.5 TEE W/NUT	509688	1
12	FITTING, XEWW 15 L 22x1.5 ELBOW W/NUT	509689	1

# REPLACEMENT PARTS

## Hydraulic Blade Tensioner

1

13	CAP, DKL 22x1.5 15 L.	509698	1	
14	NUT, M 15 L M22x1.5	509690	3	
15	SLEEVE, DPR 15 L. PIPE CLINCH	509697	2	
16	FITTING, 9/16"-18 UNF - M22x1.5 ZINC-PLATED REDUCER	510446-1	2	
17	HOSE, PHD 2T3/8x3 90W9/16UNF-W9/16UNF HYDRAULIC	509719	1	
18	WASHER, 6.4 FLAT ZINC	F81053-1	4	
19	WASHER, Z 6.1 SPLIT LOCK	F81053-3	8	
20	SCREW, M6x35 8.8 HEX SOCKET HEAD CAP ZINC	F81001-23	4	
21	WASHER, 6.5 SPECIAL FLAT ZINC	F81053-11	8	
22	NUT, M6-8-B HEX NYLON ZINC LOCK	F81031-2	2	
23	SCREW, M6x20 8.8 HEX SOCKET HEAD CAP ZINC	F81001-22	6	
	<b>HYDRAULIC BLADE TENSIONER FOR HR700-3 - COMPLETE</b>	<b>511865</b>	<b>1</b>	
	HYDRAULIC BLADE TENSIONER FOR HR500-1 - COMPLETE	509691	1	
	HYDRAULIC BLADE TENSIONER FOR HR500-2 - COMPLETE	509692	1	
	<b>HYDRAULIC BLADE TENSIONER FOR HR700-4 - COMPLETE</b>	<b>511866</b>	<b>1</b>	
	HYDRAULIC BLADE TENSIONER FOR HR500-2 - COMPLETE	509692	2	
	<b>HYDRAULIC BLADE TENSIONER FOR HR700-5 - COMPLETE</b>	<b>511867</b>	<b>1</b>	
	HYDRAULIC BLADE TENSIONER FOR HR500-1 - COMPLETE	509691	1	
	HYDRAULIC BLADE TENSIONER FOR HR500-2 - COMPLETE	509692	2	
	<b>HYDRAULIC BLADE TENSIONER FOR HR700-6 - COMPLETE</b>	<b>511868</b>	<b>1</b>	
	HYDRAULIC BLADE TENSIONER FOR HR500-2 - COMPLETE	509692	3	

<sup>1</sup> [See Section 1.18](#)

# 1 REPLACEMENT PARTS

## Hydraulic Pump Assembly

### 1.18 Hydraulic Pump Assembly

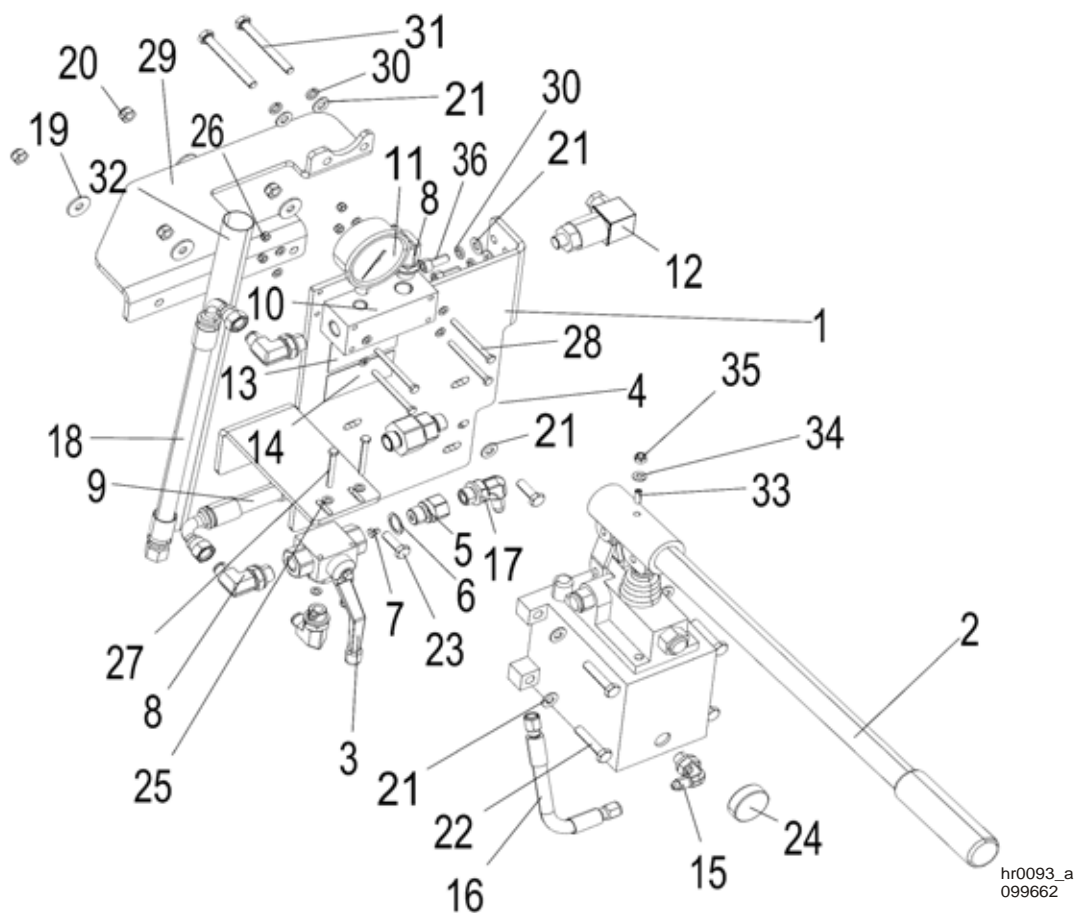

REF.	DESCRIPTION (◆ Indicates Parts Available In Assemblies Only)	PART #	QTY
	<b>HYDRAULIC PUMP ASSEMBLY, SHS/HR500/HR700</b>	<b>506733</b>	<b>1</b>
1	PLATE, MOUNTING	506734-1	1
2	PUMP, PMS12/TNK1 W/ONE-LITER TANK	092789	1
3	VALVE, RSAP3 VO2L G3/8" 3-WAY BALL	504803	1
4	VALVE, RHV12LREDA3C (HVR NW10MLED) CHECK	094559	1
	FITTING, G 3/8 W/NOZZLE	096849	1
5	FITTING, G3/8 ZINC-PLATED SPECIAL	096850-1	1
6	WASHER, 16 COPPER	F81058-3	1
7	NOZZLE, D092-O 1MM DIA. PROPANE&BUTANE	091007	1
8	FITTING, 90\$ - 3/8 BSP - 9/16 JIC ELBOW	096335	4
9	HYDRAULIC HOSE, 3/8' W/DKJ 90 DN10 9/16 UNF/DKOL DN10 M18x1.5 END FITTINGS	504831	1
10	BLOCK, MOUNTING	504829-1	1
11	GAUGE, 200 BAR (3000PSI) PRESSURE	505176	1
12	SWITCH, F4Z1/M3-20 BAR PRESSURE	504830	1
13	DECAL, PRESSURE VALUE SETTING	505348	1
14	DECAL, TVS BLADE TENSIONER HANDLE POSITION	505346	1

# REPLACEMENT PARTS

## Hydraulic Pump Assembly

**1**

15	FITTING, CA-204410-3 (W90HROKO4HJ) G1/4-JIC37.7/16-20 ELBOW	094562	1	
16	HOSE, 1/4 (0.19m) HYDRAULIC	505174	1	
17	FITTING, CA-204411-3 (W90HROKO6HJ04) G3/8-JIC37.7/16-20 ELBOW	094563	1	
18	HOSE, PHD 2T3/8x0.27 90W9/16UNF-W9/16UNF HYDRAULIC	506736	1	
19	WASHER, ISO 7093-1-8-200 HV-A2E	F81054-11	4	
20	NUT, M8 8 HEX NYLON ZINC LOCK	F81032-2	6	
21	WASHER, 8.4 FLAT ZINC	F81054-1	14	
22	BOLT, M8X40-8.8 HEX HEAD FULL THREAD ZINC	F81002-15	4	
23	BOLT, M8x25-8.8-B HEX HEAD FULL THREAD ZINC	F81002-5	2	
24	MAGNET, MW 38x12/N38 NEODYMIUM	500022	1	
25	WASHER, 5.3 FLAT ZINC	F81052-1	12	
26	NUT, M5-8-FE/ZN5 DIN985	F81030-2	6	
27	BOLT, M5x45 DIN933-A2-70 STAINLESS STEEL	F81000-22	2	
28	BOLT, M5X60 8.8 HEX HEAD ZINC	F81000-36	4	
29	BRACKET, SUPPORT	506732-1	1	
30	WASHER, 8.2 SPLIT LOCK ZINC	F81054-4	6	
31	BOLT, M8x75-8.8 HEX HEAD ZINC	F81002-91	2	
32	GUARD, VERTICAL HOSE	508713	1	
33	LATCH, GN 615.3-M6-KN BALL THREADED	096874	1	
34	WASHER, 6.4 FLAT ZINC	F81053-1	1	
35	NUT, M6-8-B HEX NYLON ZINC LOCK	F81031-2	1	
36	SCREW, M8x20-8.8 HEX SOCKET HEAD CAP ZINC	F81002-30	4	

# 1 REPLACEMENT PARTS

## Water Bottle Assembly (Option)

### 1.19 Water Bottle Assembly (Option)

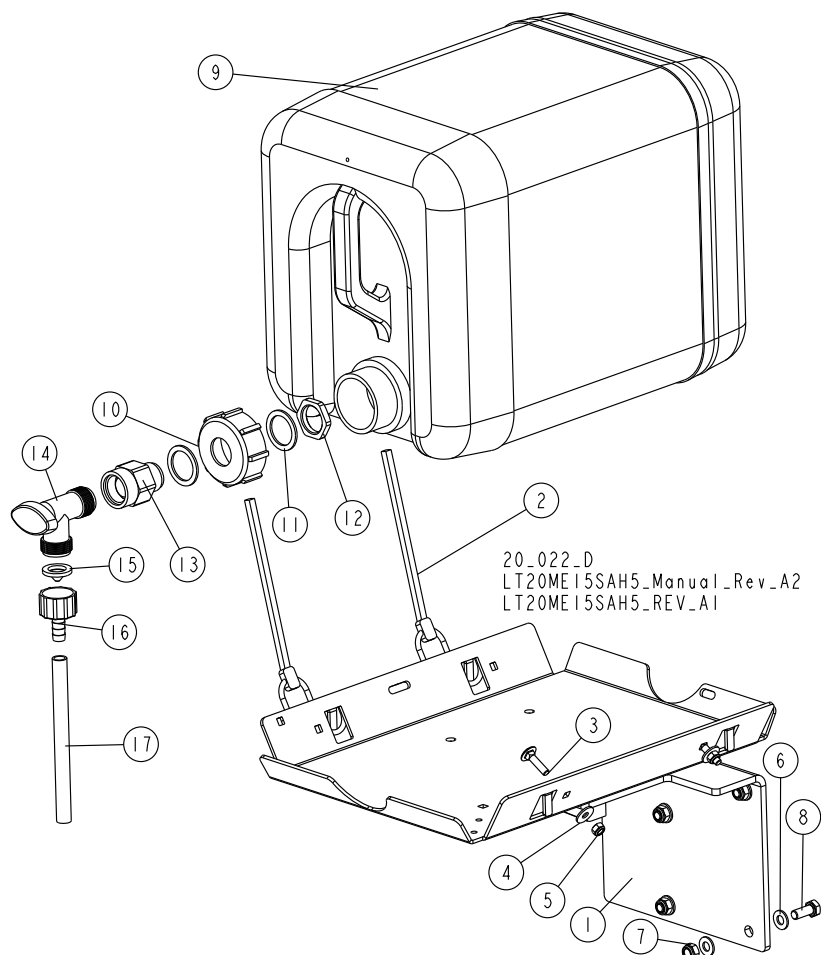

REF.	DESCRIPTION (◆ Indicates Parts Available In Assemblies Only)	PART #	QTY
	<b>BOTTLE KIT, WATER LUBE</b>	<b>091036</b>	<b>1</b>
1	TRAY WELDMENT, WATER LUBE BOTTLE	091033-1	1
2	STRAP, 20" RUBBER W/HOOK	P11668	2
3	BOLT, M6X25-8.8 CARRIAGE HEAD ZINC	F81001-20	2
4	WASHER, 6.5 SPECIAL FLAT ZINC	F81053-11	2
5	NUT, M6-8-B HEX NYLON ZINC LOCK	F81031-2	2
6	WASHER, 8.4 FLAT ZINC	F81054-1	8
7	NUT, M8-8 HEX NYLON ZINC LOCK	F81032-2	4
8	BOLT, M8X20 8.8 HEX HEAD FULL THREAD ZINC	F81002-4	4
	WATER BOTTLE - COMPLETE	513864	1
	WATER BOTTLE W/CAP	513865	1
9	BOTTLE, WATER	513866	1
10	CAP, WATER BOTTLE	513867	1
11	SEAL, 35X26X2 RUBBER	513869	2
12	NUT, 3/4 NPT GLAND	513868	1



REF.	DESCRIPTION (◆ Indicates Parts Available In Assemblies Only)	PART #	QTY
13	FITTING, 3/4FPT X 3/4MPT	014636	1
14	VALVE, 3/4 NPT ELBOW 3/4 MALE OUTLET PVC	014100	1
15	FILTER, WATER LUBE	016086	1
16	REDUCER, 5/8NPT/3/8 BARB WATER LUBE	014113	1
17	TUBING, WATER LUBE	R01885	2.1 m

### 1.20 Blade Lube System

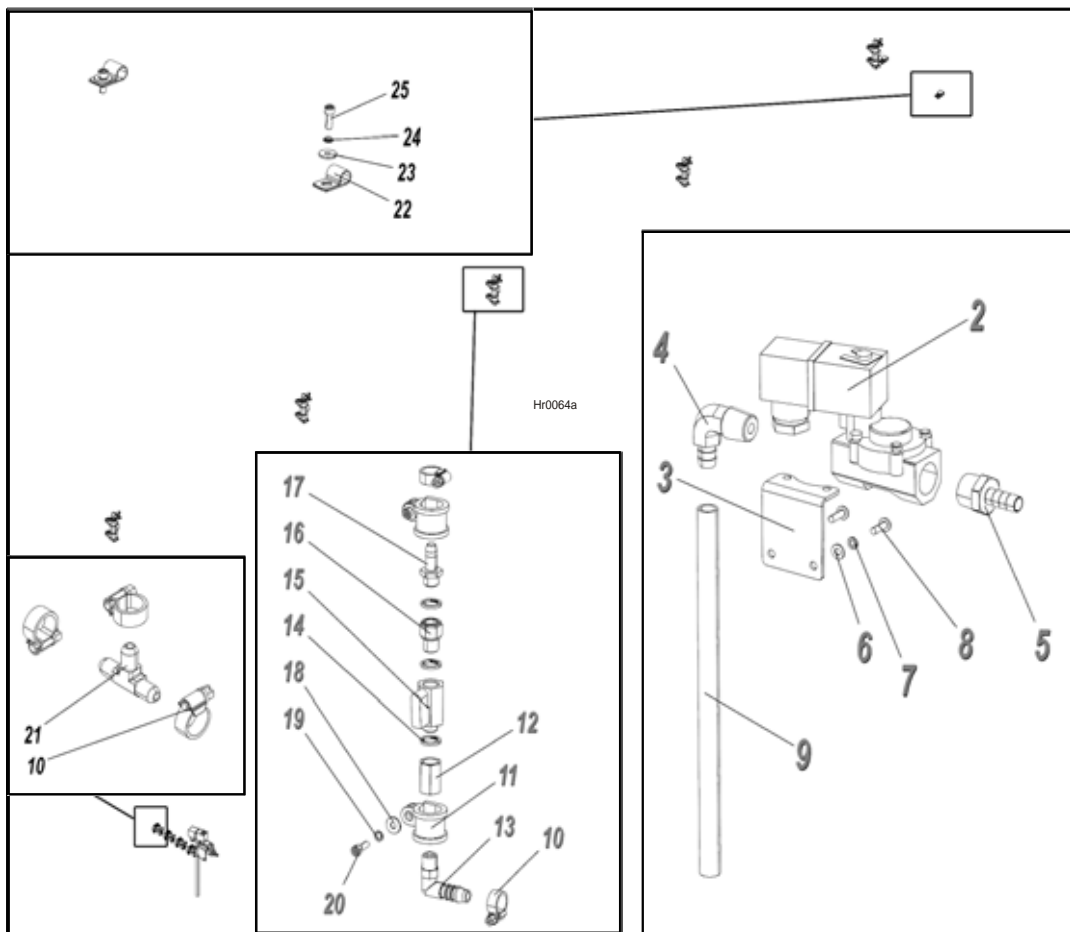

REF.	DESCRIPTION (◆ Indicates Parts Available In Assemblies Only)	PART #	QTY
	<b>BLADE LUBE KIT, HR700 (1 SAW HEAD)</b>	509710	1 / 0 / 0 / 0 / 0 / 0
	<b>BLADE LUBE KIT, HR700 (2 SAW HEADS)</b>	509711	0 / 1 / 0 / 0 / 0 / 0
	<b>BLADE LUBE KIT, HR700 (3 SAW HEADS)</b>	509712	0 / 0 / 1 / 0 / 0 / 0
	<b>BLADE LUBE KIT, HR700 (4 SAW HEADS)</b>	509713	0 / 0 / 0 / 1 / 0 / 0
	<b>BLADE LUBE KIT, HR700 (5 SAW HEADS)</b>	509714	0 / 0 / 0 / 0 / 1 / 0
	<b>BLADE LUBE KIT, HR700 (6 SAW HEADS)</b>	509715	0 / 0 / 0 / 0 / 0 / 1
1	<b>SOLENOID VALVE, BLADE LUBE SYSTEM - COMPLETE</b>	<b>509702</b>	1 / 1 / 1 / 1 / 1 / 1
2	VALVE, ASCO SCE238A002 24VDC SOLENOID	510270	1

# 1

## REPLACEMENT PARTS

### Blade Lube System

3	BRACKET, SOLENOID VALVE ZINC-PLATED	092870-1	1	
4	FITTING, 1/2NPT-3/8 BARB ELBOW	P12707	1	
5	FITTING, 1/2" HOSE END	092356	1	
6	WASHER, 4.3 FLAT ZINC	F81051-2	2	
7	WASHER, Z 4.1 SPLIT LOCK ZINC	F81051-1	2	
8	SCREW, M4X12-5.8-B CROSS RECESSED PAN HEAD ZINC	F81011-43	2	
9	TUBING, 3/8" - 1 SAW HEAD	509704	1 / 0 / 0 / 0 / 0 / 0	
	TUBING, 3/8" - 2 SAW HEADS	509705	0 / 1 / 0 / 0 / 0 / 0	
	TUBING, 3/8" - 3 SAW HEADS	509706	0 / 0 / 1 / 0 / 0 / 0	
	TUBING, 3/8" - 4 SAW HEADS	509707	0 / 0 / 0 / 1 / 0 / 0	
	TUBING, 3/8" - 5 SAW HEADS	509708	0 / 0 / 0 / 0 / 1 / 0	
	TUBING, 3/8" - 6 SAW HEADS	509709	0 / 0 / 0 / 0 / 0 / 1	
10	CLAMP, 12-20MM DIA.	F81080-3	3 / 8 / 13 / 18 / 23 / 28	
11	CLIP, RSGU 1.20/20 W1 RETAINING	F81087-2	2 / 4 / 6 / 8 / 10 / 12	
12	SLEEVE, G1/4W/G1/4W 1823300001	090808	1 / 2 / 3 / 4 / 5 / 6	
13	FITTING, WES 10/R 1/4 ELBOW	088379	1 / 2 / 3 / 4 / 5 / 6	
14	SEAL, G1/4 866-014-000-0	090809	3 / 6 / 9 / 12 / 15 / 18	
15	VALVE, FP60.KIT 28 G1/4	088380	1 / 2 / 3 / 4 / 5 / 6	
16	ADAPTER, 2521 1/4-1/4 (CAMOZZI)	097704	1 / 2 / 3 / 4 / 5 / 6	
17	BUSHING, GT13/09 NR 13539	092783	1 / 2 / 3 / 4 / 5 / 6	
18	WASHER, 5.5 SPECIAL FLAT ZINC	F81052-3	2 / 4 / 6 / 8 / 10 / 12	
19	WASHER, 5.1 SPLIT LOCK	F81052-2	2 / 4 / 6 / 8 / 10 / 12	
20	SCREW, M5X16-8.8 HEX SOCKET HEAD CAP ZINC	F81000-25	2 / 4 / 6 / 8 / 10 / 12	
21	FITTING, 3/8 BARB TEE	015485	0 / 1 / 2 / 3 / 4 / 5	
22	CLAMP, 1/2" EMT COATED	P07584	2 / 0 / 2 / 0 / 2 / 0	
23	WASHER, 6.5 SPECIAL FLAT ZINC	F81053-11	2 / 0 / 2 / 0 / 2 / 0	
24	WASHER, Z 6.1 SPLIT LOCK	F81053-3	2 / 0 / 2 / 0 / 2 / 0	
25	SCREW, M6X16 8.8 HEX SOCKET HEAD CAP ZINC	F81001-21	2 / 0 / 2 / 0 / 2 / 0	

### 1.21 HR700 Saw Head Warning Decals

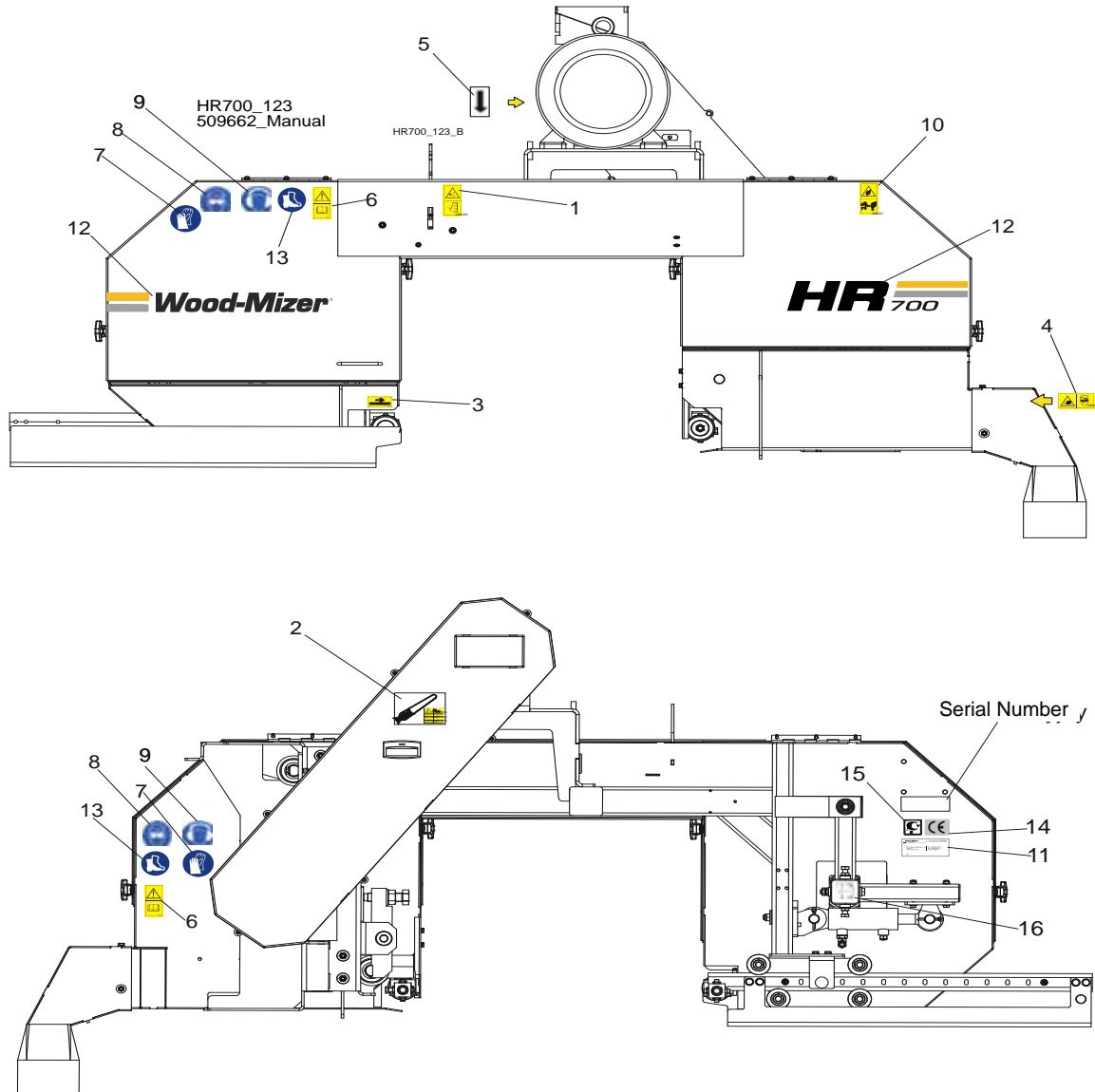

REF.	DESCRIPTION (◆ Indicates Parts Available In Assemblies Only)	PART #	QTY
	<b>DECAL KIT, HR700 - FOR 1 SAW HEAD</b>	<b>514207</b>	<b>1</b>
1	DECAL "CLOSE ALL GUARDS AND COVERS BEFORE STARTING THE MACHINE"	099220	1
2	DECAL, DRIVE-SIDE WHEEL DIAMETER, LINEAR BLADE SPEED	509025	1
3	DECAL, BLADE MOVEMENT DIRECTION (PICTOGRAM)	096321	1
4	DECAL, SAWDUST CHUTE WARNING (PICTOGRAM)	099222	1
5	DECAL, MOTOR REVOLUTIONS DIRECTION	S20097	1
6	DECAL, READ THE OPERATOR'S MANUAL (PICTOGRAM)	096317	2
7	DECAL, WEAR SAFETY GLOVES (PICTOGRAM)	512107	2
8	DECAL, EYE WARNING (PICTOGRAM)	S12004G	2
9	DECAL, EAR WARNING (PICTOGRAM)	S12005G	2
10	DECAL, KEEP A SAFE DISTANCE AWAY(PICTOGRAM)	099221	1

# 1

## REPLACEMENT PARTS

### HR700 Saw Head Warning Decals

11	DECAL, EUROPEAN HEADQUARTERS ADDRESS	015841	1	
12	DECAL KIT, HR700 NAME	514076	1	
13	DECAL, USE SAFETY BOOTS (PICTOGRAM)	501465	2	
14	DECAL, CE CERTIFIED MACHINE (SMALL)	P85070	1	
15	DECAL, RUSSIAN SAFETY CERTIFICATION	099401	1	
16	DECAL, BLADE ALIGNMENT	P11789	1	
	DECAL, COMPRESSED AIR IN THE SYSTEM EVEN AFTER ELECTRIC POWER DISCONNECTION <a href="#">See Section 1.22</a>	101176	1	
	DECAL, PNEUMATIC SYSTEM PRESSURE VALUE <a href="#">See Section 1.22</a>	513181	1	
	<b>DECAL KIT, HR700-1</b>	<b>514201</b>	<b>1</b>	
	DECAL KIT, HR700 - FOR 1 SAW HEAD	514207	1	
	DECAL, COMPRESSED AIR IN THE SYSTEM EVEN AFTER ELECTRIC POWER DISCONNECTION	101176 <sup>1</sup>	1	
	DECAL, PNEUMATIC SYSTEM PRESSURE VALUE	513181 <sup>1</sup>	1	
	<b>DECAL KIT, HR700-2</b>	<b>514202</b>	<b>1</b>	
	DECAL KIT, HR700 - FOR 1 SAW HEAD	514207	2	
	DECAL, COMPRESSED AIR IN THE SYSTEM EVEN AFTER ELECTRIC POWER DISCONNECTION	101176 <sup>1</sup>	1	
	DECAL, PNEUMATIC SYSTEM PRESSURE VALUE	513181 <sup>1</sup>	1	
	<b>DECAL KIT, HR700-3</b>	<b>514203</b>	<b>1</b>	
	DECAL KIT, HR700 - FOR 1 SAW HEAD	514207	3	
	DECAL, COMPRESSED AIR IN THE SYSTEM EVEN AFTER ELECTRIC POWER DISCONNECTION	101176 <sup>1</sup>	1	
	DECAL, PNEUMATIC SYSTEM PRESSURE VALUE	513181 <sup>1</sup>	1	
	<b>DECAL KIT, HR700-4</b>	<b>514204</b>	<b>1</b>	
	DECAL KIT, HR700 - FOR 1 SAW HEAD	514207	4	
	DECAL, COMPRESSED AIR IN THE SYSTEM EVEN AFTER ELECTRIC POWER DISCONNECTION	101176 <sup>1</sup>	1	
	DECAL, PNEUMATIC SYSTEM PRESSURE VALUE	513181 <sup>1</sup>	1	
	<b>DECAL KIT, HR700-5</b>	<b>514205</b>	<b>1</b>	
	DECAL KIT, HR700 - FOR 1 SAW HEAD	514207	5	
	DECAL, COMPRESSED AIR IN THE SYSTEM EVEN AFTER ELECTRIC POWER DISCONNECTION	101176 <sup>1</sup>	1	
	DECAL, PNEUMATIC SYSTEM PRESSURE VALUE	513181 <sup>1</sup>	1	
	<b>DECAL KIT, HR700-6</b>	<b>514206</b>	<b>1</b>	
	DECAL KIT, HR700 - FOR 1 SAW HEAD	514207	6	
	DECAL, COMPRESSED AIR IN THE SYSTEM EVEN AFTER ELECTRIC POWER DISCONNECTION	101176 <sup>1</sup>	1	
	DECAL, PNEUMATIC SYSTEM PRESSURE VALUE	513181 <sup>1</sup>	1	

<sup>1</sup> [See Section 1.22](#)

**1.22 Pneumatic System Decals**

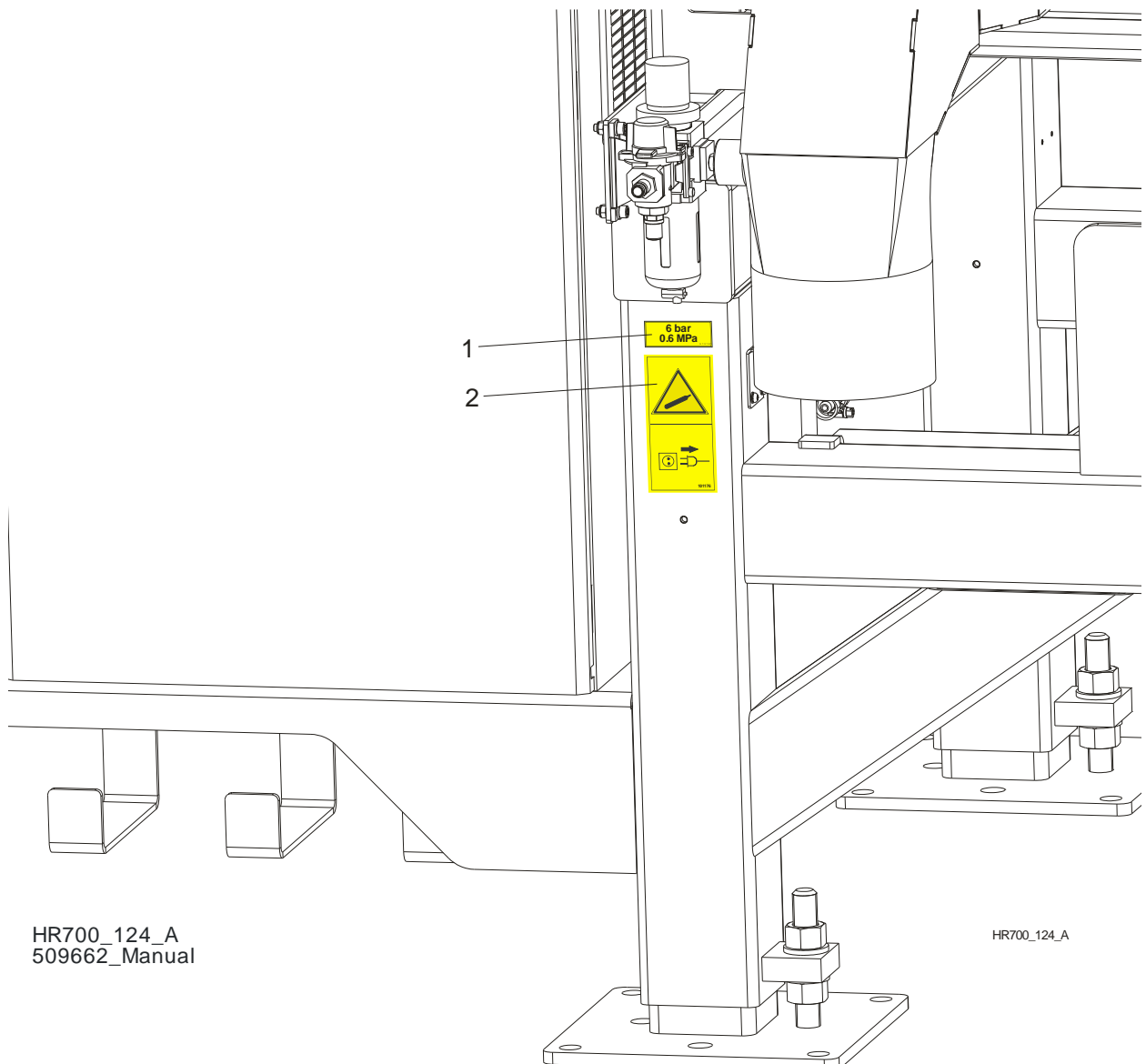

HR700\_124\_A  
 509662\_Manual

HR700\_124\_A

REF.	DESCRIPTION (◆ Indicates Parts Available In Assemblies Only)	PART #	QTY
1	DECAL, COMPRESSED AIR IN THE SYSTEM EVEN AFTER ELECTRIC POWER DISCONNECTION	101176	1
2	DECAL, PNEUMATIC SYSTEM PRESSURE VALUE	513181	1

# 1 REPLACEMENT PARTS

## HR700 Saw Head

### 1.23 HR700 Saw Head

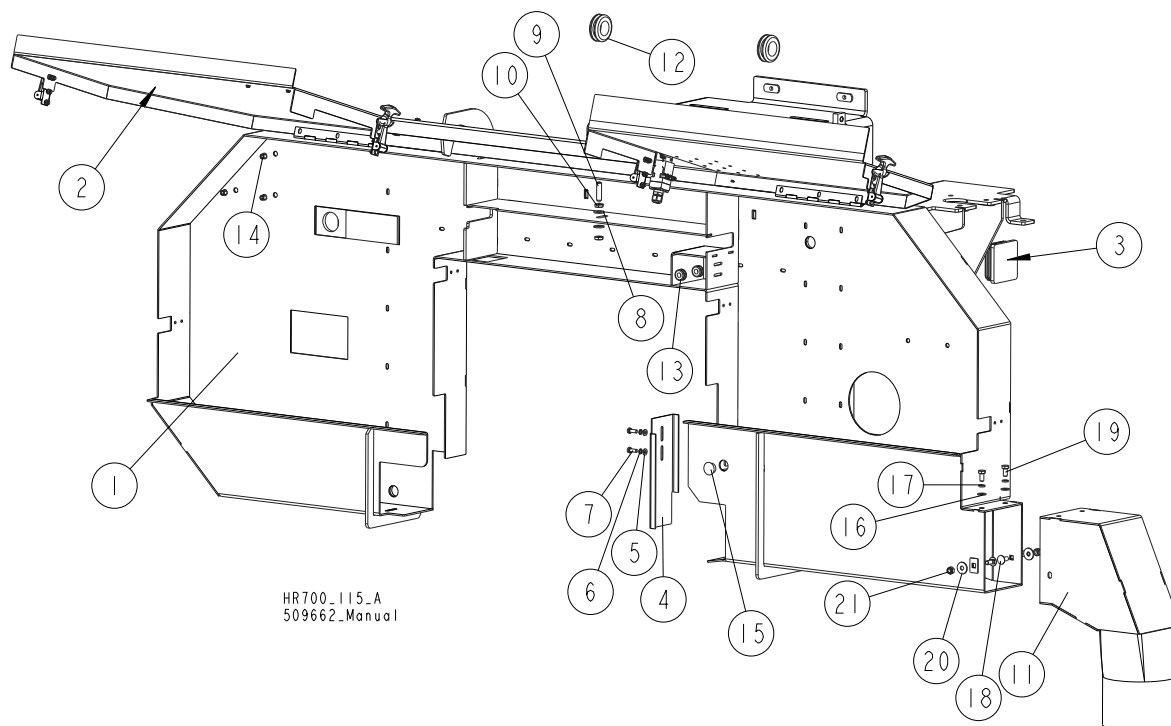

REF.	DESCRIPTION (◆ Indicates Parts Available In Assemblies Only)	PART #	QTY
1	SAW HEAD, SHS/HR700	506714-1	1
2	COVER, SHS/HR700 FRONT - COMPLETE <a href="#">See Section 1.24</a>	506762	1
3	CAP, 80X80 GR 2-4 #111227 TUBE END	089644	4
4	GUARD, BLADE GUIDE ROLLER	094737-1	1
5	WASHER, 6.4 FLAT ZINC	F81053-1	2
6	WASHER, Z 6.1 SPLIT LOCK	F81053-3	2
7	BOLT, M6X16-8.8 HEX HEAD FULL THREAD ZINC	F81001-15	2
8	WASHER, 10.5 FLAT ZINC	F81055-1	2
9	SCREW, M10X40-45H HEX SOCKET SET CONE POINT ZINC	F81003-61	1
10	NUT, M10-04-A ZINC-PLATED THIN	F81033-6	2
11	CHUTE, RESAW SAWDUST	094059-1	1
12	GROMMET, 30X42X8 RUBBER	509717	2
13	GROMMET, 3/8" ID RUBBER	025248	2
14	PLUG, SR1086-9.5 #46009 (MOSS) BLANKING	096846	3
15	PLUG, SR1086 22.2 HOLE	093544	1
16	WASHER, 8.4 FLAT ZINC	F81054-1	2
17	WASHER, 8.2 SPLIT LOCK ZINC	F81054-4	2
18	BOLT, M8X20-8.8 CARRIAGE HEAD ZINC	F81002-11	2
19	BOLT, M8X16-8.8-B HEX HEAD FULL THREAD ZINC	F81002-20	2
20	WASHER, ISO 7093-1-8-200 HV-A2E	F81054-11	2
21	NUT, M8-8-B HEX NYLON ZINC LOCK	F81032-2	2

1.24 Front Blade Housing Cover

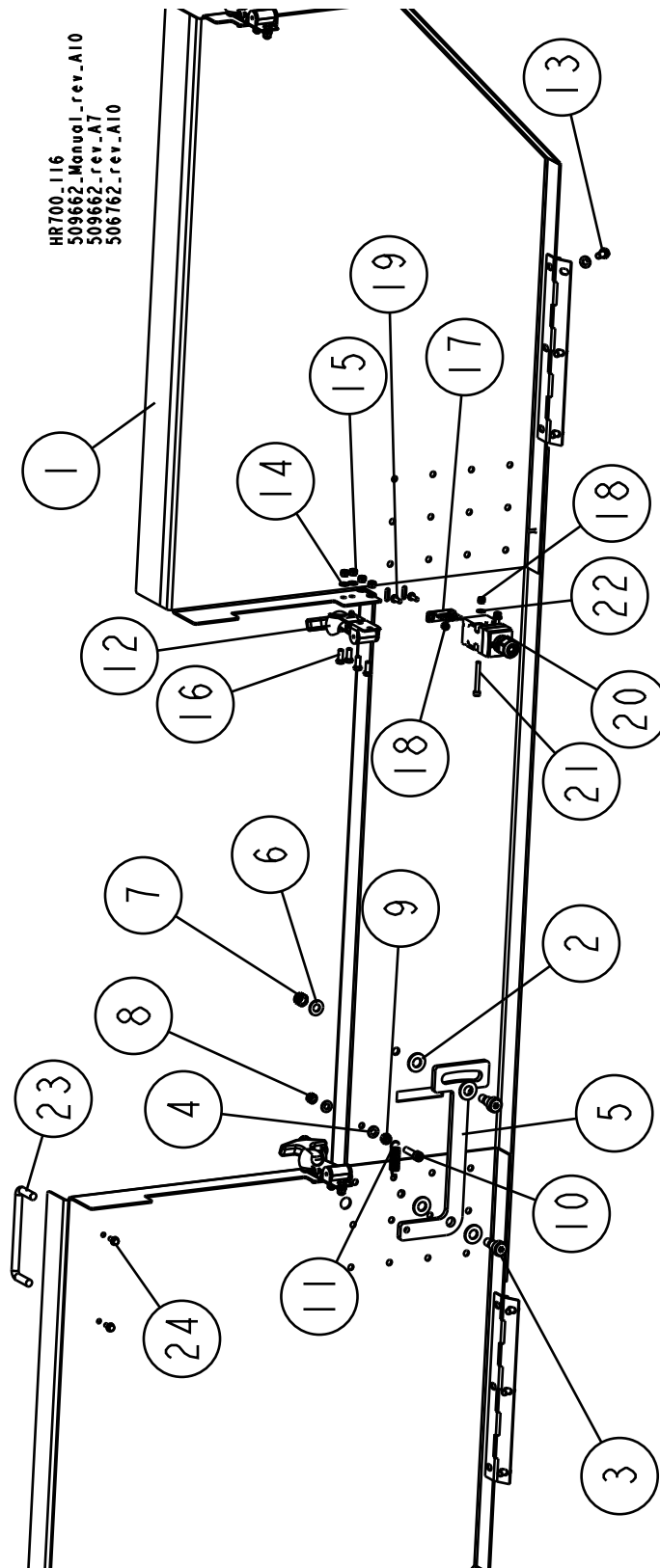

# 1

## REPLACEMENT PARTS

### Front Blade Housing Cover

REF.	DESCRIPTION (◆ Indicates Parts Available In Assemblies Only)	PART #	QTY	
	<b>COVER, SHS/HR700 FRONT - COMPLETE</b>	<b>506762</b>	<b>1</b>	
1	COVER, SHS/HR700 FRONT	506763-1	1	
2	WASHER, 10.5 FLAT ZINC	F81055-1	4	
3	BOLT, 10/M8X12-12.9 BOSSARD SHOULDER	F81003-62	2	
4	WASHER, 6.4 FLAT ZINC	F81053-1	8	
5	PAWL, LOCKING	090643-1	1	
6	WASHER, 8.4 FLAT ZINC	F81054-1	2	
7	NUT, M8 8 HEX NYLON ZINC LOCK	F81032-2	2	
8	NUT, M6-8-B HEX NYLON ZINC LOCK	F81031-2	1	
9	NUT, M6 8 HEX ZINC	F81031-1	1	
10	SCREW, M6X25-8.8 HEX SOCKET HEAD CAP ZINC	F81001-41	1	
11	SPRING, 1.6X12X38 EXTENSION	092208	1	
12	LATCH, FLEXIBLE DRAW	014829	4	
13	BOLT, M6X12 8.8 HEX HEAD FULL THREAD ZINC	F81001-7	6	
14	WASHER, 5.3 FLAT ZINC	F81052-1	16	
15	NUT, M5-8 DIN985 ZINC-PLATED	F81030-2	16	
16	BOLT, M5X12 5.8 HEX HEAD FULL THREAD ZINC	F81000-5	16	
17	KEY, AZ17/170-B5 SAFETY SWITCH	094422	1	
18	NUT, M4-8 HEX NYLON ZINC LOCK	F81029-1	4	
19	SCREW, M4X12-5.8-B CROSS RECESSED PAN HEAD ZINC	F81011-43	2	
20	SWITCH, AZ17-11ZRK SAFETY	094232	1	
21	SCREW, M4X35 8.8 HEX SOCKET HEAD CAP ZINC	F81011-34	2	
22	WASHER, 4.3 FLAT ZINC	F81051-2	2	
23	HANDLE, 4"	P08065	1	
24	SCREW, #8-32X3/8 SELF-TAPPING	F05015-8	2	



### 1.25 Adjustable Saw Head Guide Rollers

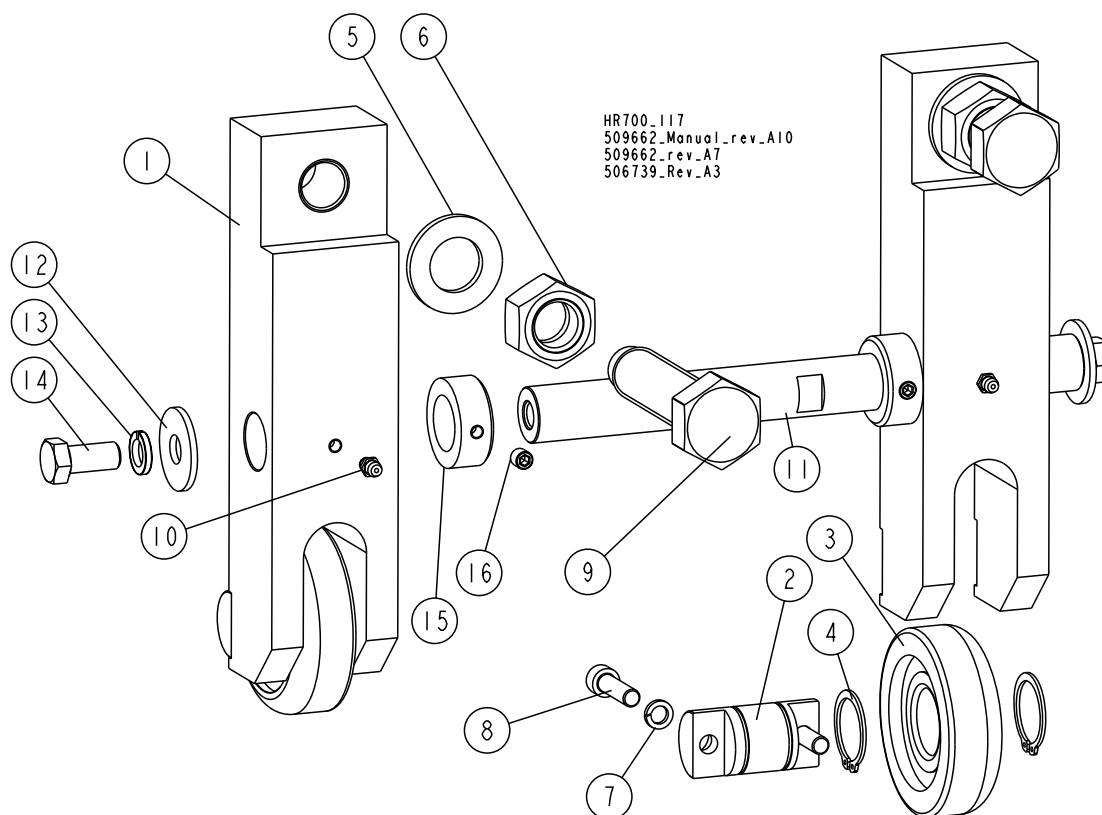

REF.	DESCRIPTION (◆ Indicates Parts Available In Assemblies Only)	PART #	QTY
	<b>ROLLER ASSEMBLY, ADJUSTABLE SAW HEAD GUIDE</b>	<b>506739</b>	<b>1</b>
1	BAR, ROLLER ZINC-PLATED MOUNT	506741-1	2
2	SHAFT, GUIDE ROLLER ZINC-PLATED	506742-1	2
3	ROLLER, SBBA3084-01 (COMPLEX)	088433	2
4	RING, 30Z OUTSIDE RETAINING	F81090-23	4
5	WASHER, 25 FLAT ZINC	F81061-3	2
6	NUT, M24X2-8-B HEX ZINC	F81039-11	2
7	WASHER, 8.2 SPLIT LOCK ZINC	F81054-4	4
8	SCREW, M8X30-8.8 HEX SOCKET HEAD CAP ZINC	F81002-31	4
9	BOLT, M24X2X95 ZINC-PLATED SPECIAL	506748-1	2
10	FITTING, M6 STRAIGHT GREASE	086280	2
11	ROD, GUIDE ROLLER CONNECTION	506747	1
12	WASHER, 13 SPECIAL FLAT ZINC	F81056-14	2
13	WASHER, Z12.2 SPLIT LOCK ZINC	F81056-2	2
14	BOLT, M12X25-8.8 HEX HEAD FULL THREAD ZINC	F81004-31	2
15	RING, 25 STOPPING LIGHT TYPE	F81039-4	2
16	SCREW, M8X8-33H HEX SOCKET FLAT POINT ZINC SET	F81014-1	2

# 1 REPLACEMENT PARTS

## Fixed Saw Head Guide Rollers

### 1.26 Fixed Saw Head Guide Rollers

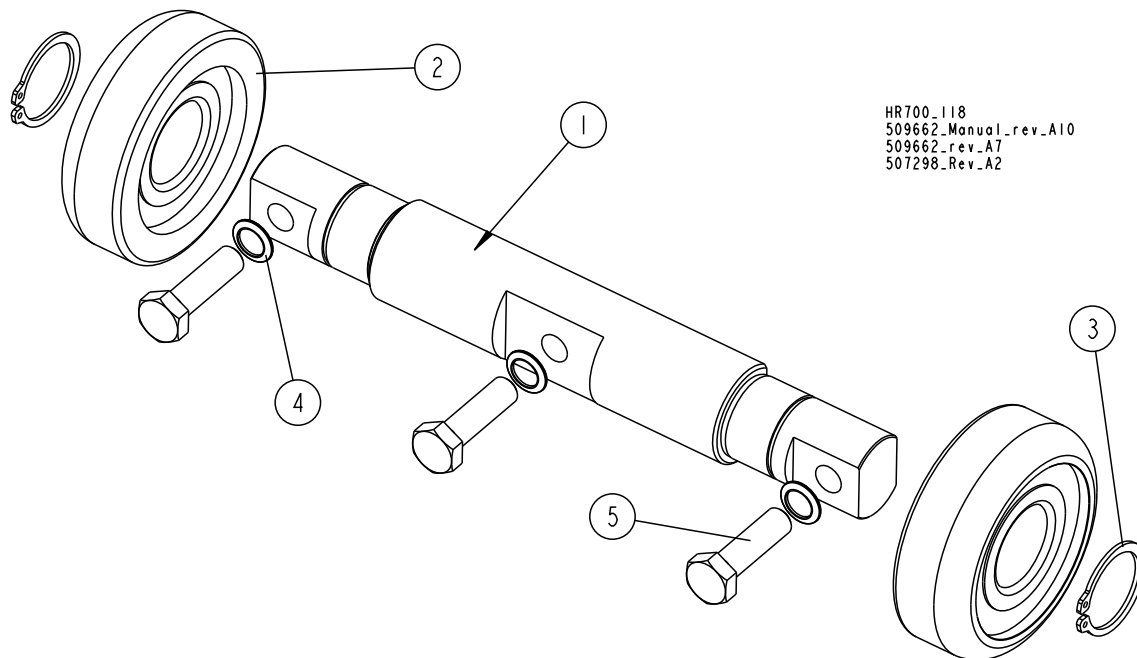

REF.	DESCRIPTION (◆ Indicates Parts Available In Assemblies Only)	PART #	QTY
	<b>ROLLER ASSEMBLY, FIXED SAW HEAD GUIDE</b>	<b>507298</b>	<b>1</b>
1	SHAFT, FIXED GUIDE ROLLER ZINC-PLATED	088815-1	1
2	ROLLER, SBBA3084-01 (COMPLEX)	088433	2
3	RING, 30Z OUTSIDE RETAINING	F81090-23	2
4	WASHER, 791 M10/10.5 SPLIT LOCK	F81055-7	3
5	BOLT, M10X35 8.8 HEX HEAD FULL THREAD ZINC	F81003-17	3

1.27 HR700 Vertical Mast

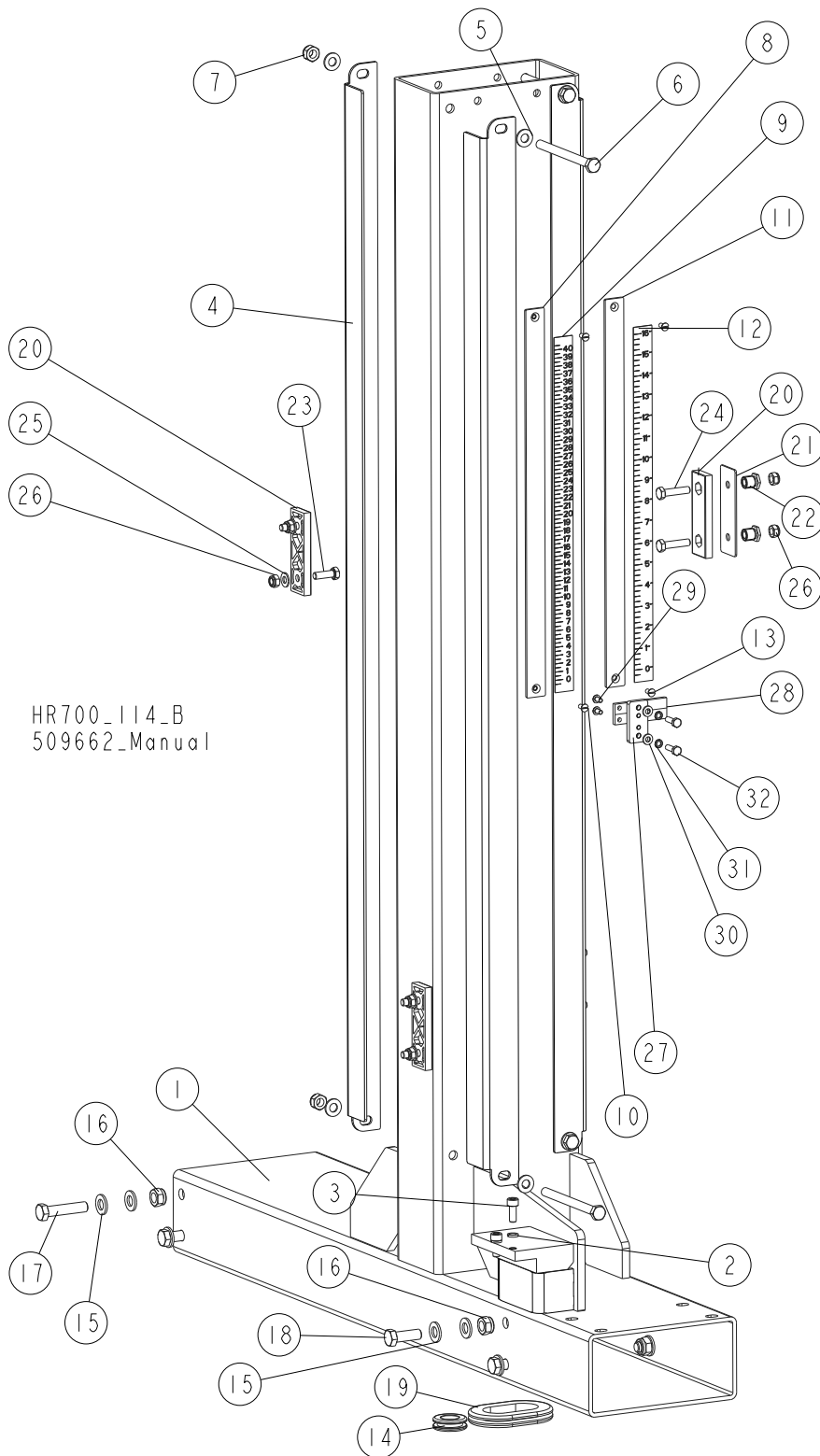

HR700\_114-B  
509662\_Manual

## 1

**REPLACEMENT PARTS***HR700 Vertical Mast*

REF.	DESCRIPTION (◆ Indicates Parts Available In Assemblies Only)	PART #	QTY	
	<b>MAST, HR700 COMPLETE</b>	<b>508697</b>	<b>1</b>	
1	MAST, HR700	508698-1	1	
2	WASHER, 8.2 SPLIT LOCK ZINC	F81054-4	2	
3	SCREW, M8X20-8.8 HEX SOCKET HEAD CAP ZINC	F81002-30	2	
4	ANGLE, MAST TUBE	513489	4	
5	WASHER, 10.5 FLAT ZINC	F81055-1	8	
6	BOLT, M10X125 8.8 HEX HEAD ZINC	F81003-18	4	
7	NUT, M10-8-B HEX NYLON ZINC LOCK	F81033-1	4	
	SCALE, METRIC BLADE HEIGHT - COMPLETE	507302	1	
8	BAR, SHS/HR700 BLADE HEIGHT SCALE	507303	1	
9	DECAL, 0-40 METRIC BLADE HEIGHT SCALE	507304	1	
10	SCREW, M5X12- 5.8-B SLOTTED COUNTERSUNK HEAD ZINC	F81000-15	2	
	SCALE, INCH BLADE HEIGHT - COMPLETE	507305	1	
11	BAR, SHS/HR700 BLADE HEIGHT SCALE	507303	1	
12	DECAL, 0-15.75 INCH BLADE HEIGHT SCALE	507306	1	
13	SCREW, M5X12- 5.8-B SLOTTED COUNTERSUNK HEAD ZINC	F81000-15	2	
14	GROMMET, 22MM ID RUBBER	087400	6	
15	WASHER, 13MM FLAT ZINC	F81056-1	16	
16	NUT, M12-8 HEX NYLON ZINC LOCK	F81034-2	8	
17	BOLT, M12X55-8.8 HEX HEAD ZINC	F81004-12	4	
18	BOLT, M12X35 8.8 HEX HEAD FULL THREAD ZINC	F81004-24	4	
19	GROMMET	089532	2	
20	PAD, DELRIN UP/DOWN SLIDE	M04096	4	
21	PLATE, SLIDE PAD MOUNTING	093246-1	2	
22	.NUT, SLIDE PAD ZINC-PLATED ADJUSTMENT	086683-1	4	
23	BOLT, M8X25-8.8-B HEX HEAD FULL THREAD ZINC	F81002-5	4	
24	BOLT, M8X35-8.8 HEX HEAD FULL THREAD ZINC	F81002-13	4	
25	WASHER, 8.4 FLAT ZINC	F81054-1	4	
26	NUT, M8 8 HEX NYLON ZINC LOCK	F81032-2	8	
	INDICATOR, BLADE HEIGHT SCALE - COMPLETE	507299	1	
27	PLATE, SCALE INDICATOR ZINC-PLATED MOUNTING	507301-1	1	
28	INDICATOR, BLADE HEIGHT SCALE	094821	1	
29	BOLT M5x10 wg. ISO 7380	F81000-32	2	
30	WASHER, 6.4 FLAT ZINC	F81053-1	2	
31	WASHER, Z 6.1 SPLIT LOCK ZINC	F81053-3	2	
32	BOLT, M6X20 8.8 HEX HEAD FULL THREAD ZINC	F81001-2	2	

1.28 Drive Belt Guard

HR700\_119  
 509662\_Manual\_Rev\_All  
 509662\_rev\_A7  
 506767\_Rev\_A4

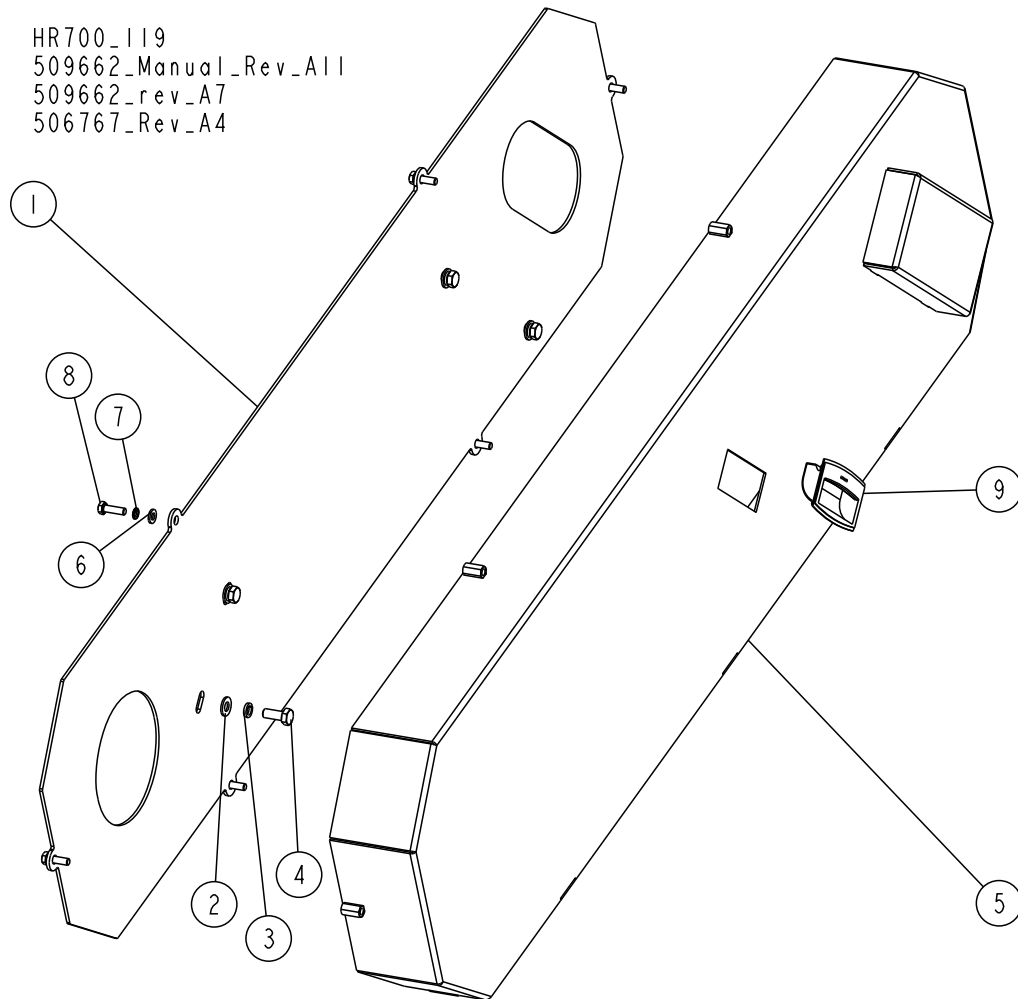

REF.	DESCRIPTION (◆ Indicates Parts Available In Assemblies Only)	PART #	QTY
	<b>GUARD, DRIVE BELT - COMPLETE</b>	<b>506767</b>	<b>1</b>
1	PLATE, DRIVE BELT GUARD REAR	506731-1	1
2	WASHER, 8.4 FLAT ZINC	F81054-1	4
3	WASHER, 8.2 SPLIT LOCK ZINC	F81054-4	4
4	BOLT, M8X20 8.8 HEX HEAD FULL THREAD ZINC	F81002-4	4
5	GUARD, DRIVE BELT	506768-1	1
6	WASHER, 6.4 FLAT ZINC	F81053-1	6
7	WASHER, Z 6.1 SPLIT LOCK ZINC	F81053-3	6
8	BOLT, M6X20 8.8 HEX HEAD FULL THREAD ZINC	F81001-2	6
9	HANDLE, EPR.90-PF-C1(261051-C1) SNAP-IN FLUSH PULL	100012	1

# 1 REPLACEMENT PARTS

## Blade Guide Arm

### 1.29 Blade Guide Arm

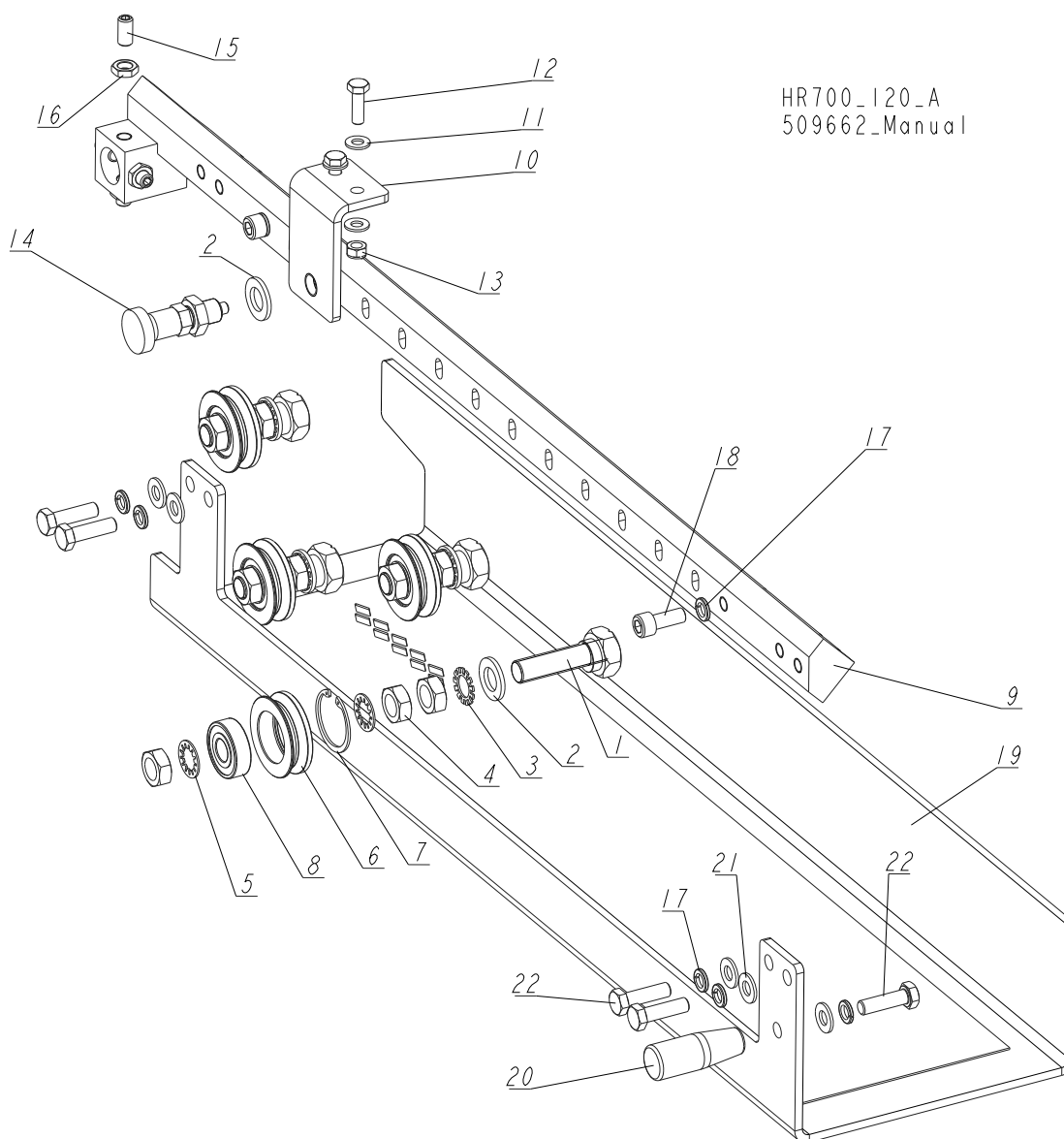

REF.	DESCRIPTION (◆ Indicates Parts Available In Assemblies Only)	PART #	QTY
	<b>ARM, ADJUSTABLE BLADE GUIDE - COMPLETE</b>	<b>506756</b>	<b>1</b>
1	BOLT WELDMENT, ECCENTRIC	086508-1	4
2	WASHER, 17 SPLIT LOCK ZINC	F81058-1	5
3	WASHER, 5/8" EXTERNAL STAR	F05011-26	4
4	NUT, 5/8"-18 HEX ZINC	F05010-11	12
5	WASHER, 5/8" INTERNAL STAR	F05011-25	8
	ROLLER ASSEMBLY, V-GROOVE W/BEARING	093855	4
6	ROLLER, V-GROOVE ZINC-PLATED	093856-1	1
7	RING, W40 INSIDE RETAINING	F81090-3	1
8	BEARING, 6203 2RSP6- 5/8 CX	095087	1

**REPLACEMENT PARTS***Blade Guide Arm***1**

REF.	DESCRIPTION (◆ Indicates Parts Available In Assemblies Only)	PART #	QTY	
9	ARM, BLADE GUIDE ZINC-PLATED	506757-1	1	
10	BRACKET, DETENT PIN MOUNT	099077-1	1	
11	WASHER, 8.4 FLAT ZINC	F81054-1	4	
12	BOLT, M8X25-8.8-B HEX HEAD FULL THREAD ZINC	F81002-5	2	
13	NUT, M8 8 HEX NYLON ZINC LOCK	F81032-2	2	
14	PIN, 45308DNW DETENT	089939	1	
15	SCREW, M10X1X20 DIN 913 STAINLESS STEEL SET	F81015-1	4	
16	NUT, M10X1-04-ST-A2E ISO8675 THIN	F81033-10	4	
17	WASHER, Z 10.2 SPLIT LOCK ZINC	F81055-2	7	
18	SCREW, M10X25 8.8 HEX SOCKET HEAD CAP ZINC	F81003-32	2	
19	GUARD, BLADE	506761-1	1	
20	KNOB, M10 13870M10 CRANK HANDLE	089445	1	
21	WASHER, 10.5 FLAT ZINC	F81055-1	5	
22	BOLT, M10X35 8.8 HEX HEAD FULL THREAD ZINC	F81003-17	5	

# 1

## REPLACEMENT PARTS

E20 (Standard) & E25 (Option) Motors

### 1.30 E20 (Standard) & E25 (Option) Motors

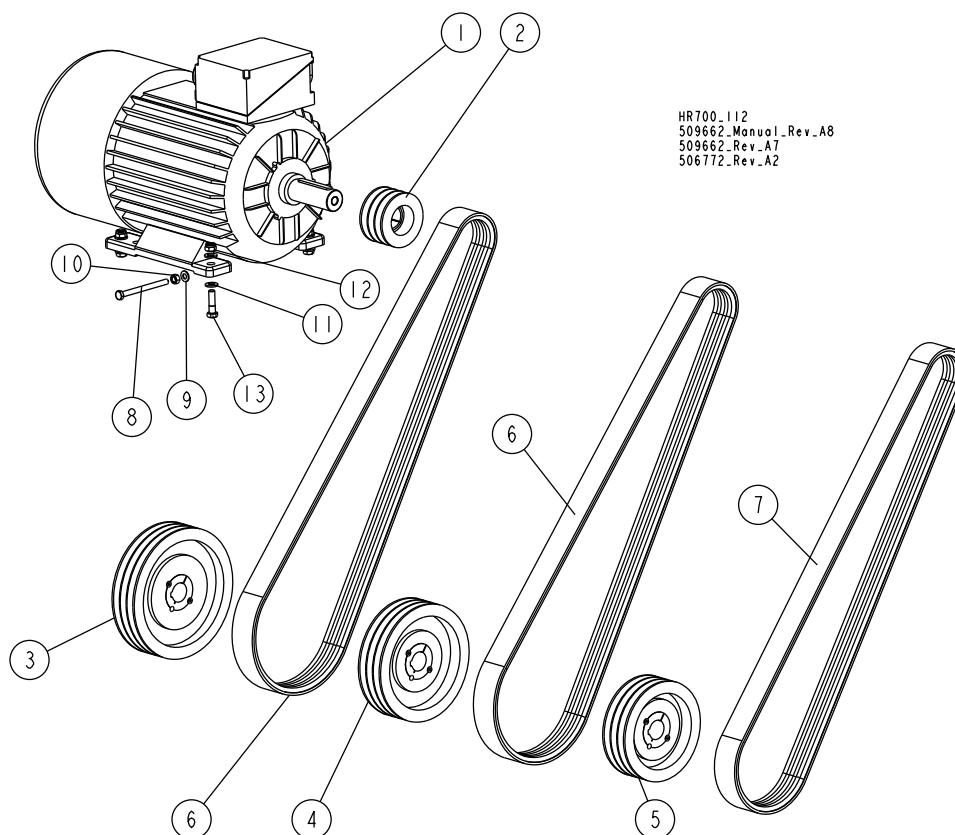

REF.	DESCRIPTION (◆ Indicates Parts Available In Assemblies Only)	PART #	QTY
	<b>MOTOR, E25 SHS/HR700 MAIN - COMPLETE</b>	<b>506771</b>	<b>1/0</b>
	<b>MOTOR, E20 SHS/HR700 MAIN - COMPLETE</b>	<b>506772</b>	<b>0/1</b>
1	MOTOR, PSG-160 L4 18,5KW + H-160+	508712	1/0
	MOTOR, 2SIE-160 L4 400 50HZ+H160 15KW 1460 1/MIN.	507317	0/1
2	PULLEY, PBT SPB3 100/42, (F02313+T31081)	506753 <sup>1 2 3</sup>	1
3	PULLEY, PBT SPB3 250/38, (F01816+T31138)	507273 <sup>2</sup>	1
4	PULLEY, PBT SPB3 224/38, (F01876+T31124)	506755 <sup>1</sup>	1
5	PULLEY, PBT SPB3 190/38, (F01802+T31124)	506754 <sup>3</sup>	1
6	V-BELT, KB RED POWER II 3SPB 2240 OPT TRIPLE	088993 <sup>1 2</sup>	2
7	V-BELT, KB RED POWER II 3SPB 2160 TRIPLE	507311 <sup>3</sup>	1
8	BOLT, M10X120-8.8 HEX HEAD FULL THREAD ZINC	F81003-47	2
9	WASHER, 10.5 FLAT ZINC	F81055-1	2
10	NUT, M10 8 HEX ZINC	F81033-3	2
11	WASHER, 13 FLAT ZINC	F81056-1	8
12	NUT, M12 8 HEX NYLON ZINC LOCK	F81034-2	4
13	BOLT, M12X45 8.8 HEX HEAD ZINC	F81004-32	4

<sup>1</sup> For standard blade speed of V=20m/s, mount pulley #506753 on motor shaft, and pulley #506755 with belt #088993 on drive shaft.

<sup>2</sup> For optional blade speed of V=18m/s, mount pulley #506753 on motor shaft, and pulley #507273 with belt #088993 on drive shaft.

<sup>3</sup> For optional blade speed of V=24m/s, mount pulley #506753 on motor shaft, and pulley #506754 with belt #507311 on drive shaft.



**1.31 E15 Motor Assembly (Option)**

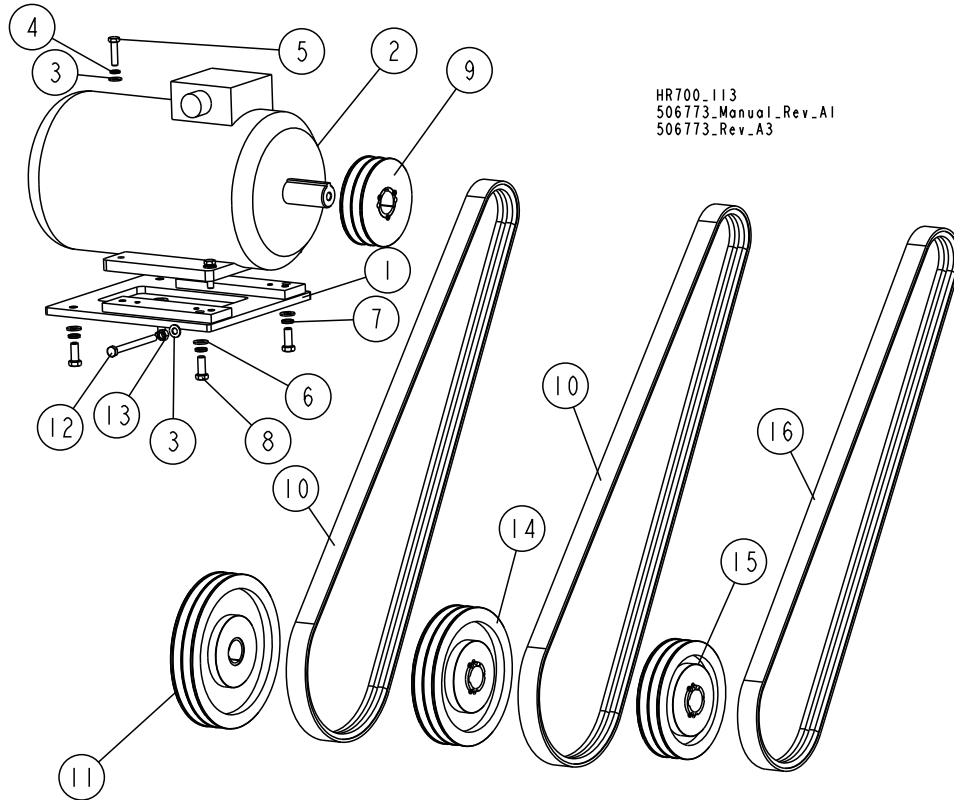

REF.	DESCRIPTION (◆ Indicates Parts Available In Assemblies Only)	PART #	QTY
	<b>MOTOR, E15 SHS/HR700 MAIN - COMPLETE</b>	<b>506773</b>	<b>1</b>
1	PLATE, E15 HR-L MOTOR MOUNT	506774-1	1
2	MOTOR, SG132M-4PC-HM (11KW,1500 r.p.m.)	093219	1
3	WASHER, 10.5 FLAT ZINC	F81055-1	6
4	WASHER, Z 10.2 SPLIT LOCK ZINC	F81055-2	4
5	BOLT, M10X40-8.8 HEX HEAD FULL THREAD ZINC	F81003-16	4
6	WASHER, 13 FLATZINC	F81056-1	4
7	WASHER, Z12.2 SPLIT LOCK ZINC	F81056-2	4
8	BOLT, M12X30 8.8 HEX HEAD FULL THREAD ZINC	F81004-22	4
9	PULLEY, SPB-B-5VN100X2CGROOVES/N38(F02312+T31079)	500176 <sup>1 2 3</sup>	1
10	V-BELT, KB RED POWER II 2SPB 2240 TRIPLE	507307 <sup>1 2</sup>	2
11	PULLEY, SPB-B-5VN250X2 GROOVES /N38 (F02365+T31124)	507274 <sup>2</sup>	1
12	BOLT, M10X120-8.8 HEX HEAD FULL THREAD ZINC	F81003-47	2
13	NUT, M10 8 HEX ZINC	F81033-3	2
14	PULLEY, SPB-B-5VN224X2 GROOVES /N38 (F02359+T31124)	500177	1
15	PULLEY, SPB-B-5V N190X 2 GROOVES /N38(F02347+T31124)	500569 <sup>3</sup>	1
16	V-BELT, KB RED POWER II 2SPB 2160 TRIPLE	507315 <sup>3</sup>	1

<sup>1</sup> For standard blade speed of V=20m/s, mount pulley #500176 on motor shaft, and pulley #500177 with belt #507307 on drive shaft.

<sup>2</sup> For optional blade speed of V=18m/s, mount pulley #500176 on motor shaft, and pulley #507274 with belt #507307 on drive shaft.

<sup>3</sup> For optional blade speed of V=24m/s, mount pulley #500176 on motor shaft, and pulley #500569 with belt #507315 on drive shaft.

# 1 REPLACEMENT PARTS

## Idle Roller Table, SLPIRT

### 1.32 Idle Roller Table, SLPIRT

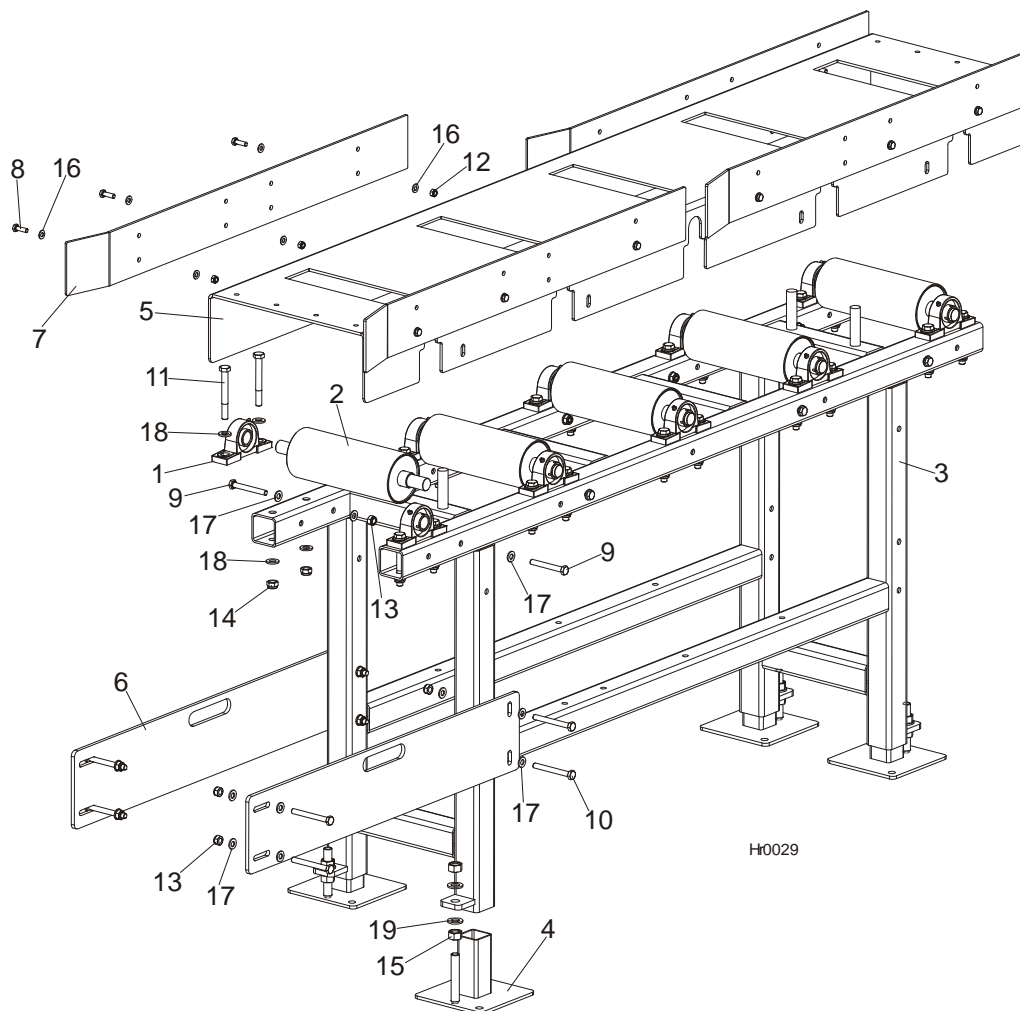

REF.	DESCRIPTION (◆ Indicates Parts Available In Assemblies Only)	PART #	QTY
	<b>HR IDLE ROLLER TABLE</b>	<b>SLPIRT</b>	<b>1</b>
	IDLE RETURN TABLE - COMPLETE	099659	1
1	BEARING, UCP 205 CX W/HOUSING	088468	10
2	ROLLER, SVS FEED	098140-1	5
3	FRAME, SVS INFEED & OUTFEED TABLE	099168-1	1
4	FOOT ASSEMBLY, TABLE LEG	099281-1	4
5	PLATE, RETURN TABLE TOP	099686-1	1
6	PLATE, RETURN TABLE CONNECTION	099687-1	2
7	PLATE, GUIDE	099688-1	4
8	BOLT, M8x25-8.8-B HEX HEAD FULL THREAD ZINC	F81002-5	12
9	BOLT, M10x80-8.8 HEX HEAD ZINC	F81003-50	9
10	BOLT, M10x90-8.8-B HEX HEAD ZINC	F81003-66	8
11	BOLT, M12x100-8.8 HEX HEAD ZINC	F81004-3	20

## REPLACEMENT PARTS

*Idle Roller Table, SLPIRT*

**1**

12	NUT, M8-8-B HEX NYLON ZINC LOCK	F81032-2	12	
13	NUT, M10-8-B HEX NYLON ZINC LOCK	F81033-1	17	
14	NUT, M12-8 HEX NYLON ZINC LOCK	F81034-2	20	
15	NUT, M16-5.8 HEX ZINC	F81036-1	8	
16	WASHER, 8.4 FLAT ZINC	F81054-1	23	
17	WASHER, 10.5 FLAT ZINC	F81055-1	34	
18	WASHER, 13 FLAT ZINC	F81056-1	40	
19	WASHER, 17 FLAT ZINC	F81058-1	8	



# REPLACEMENT PARTS

## Cross Roller Table, SLPCRT

### 1.33 Cross Roller Table, SLPCRT

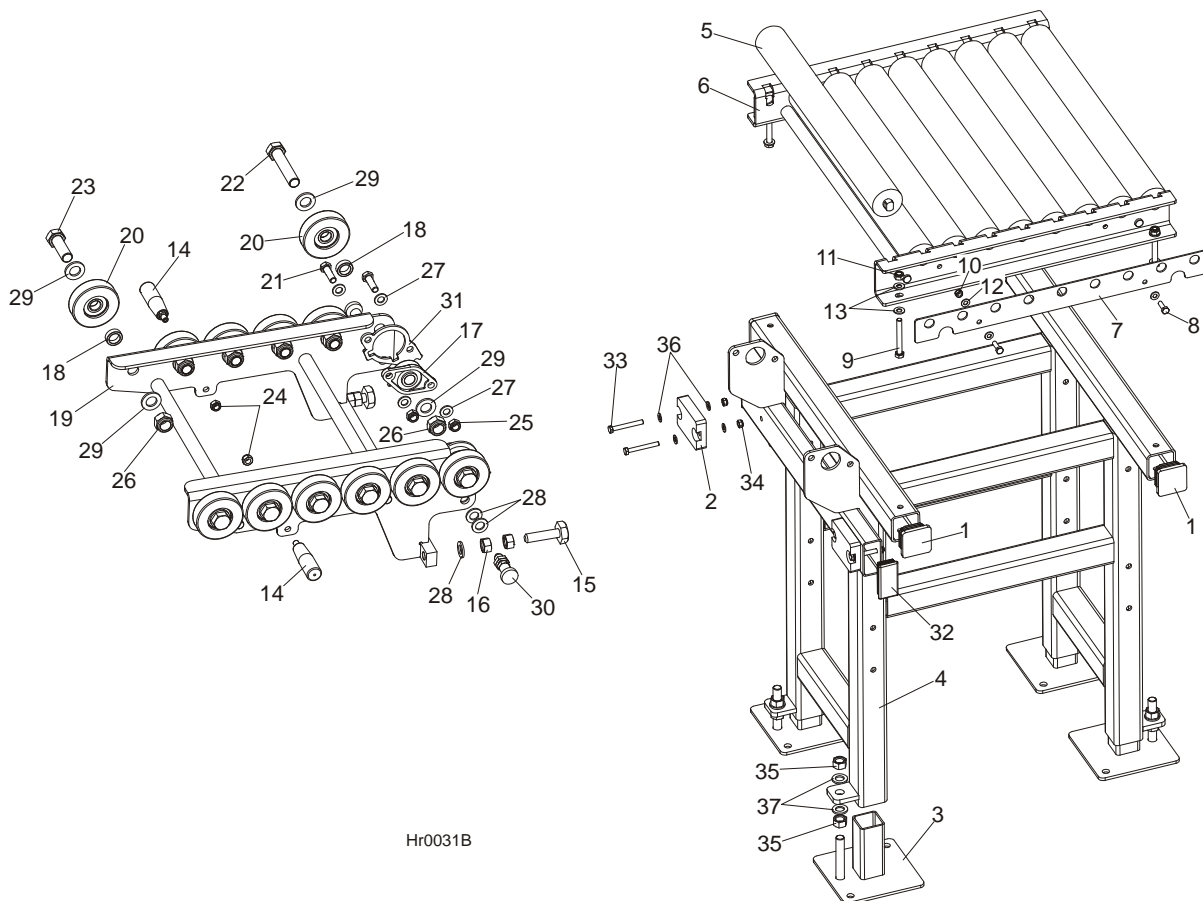

REF.	DESCRIPTION (◆ Indicates Parts Available In Assemblies Only)	PART #	QTY
	<b>HR CROSS ROLLER TABLE</b>	<b>SLPCRT</b>	<b>1</b>
	COMPLETE CROSS RETURN TABLE	099648	1
1	CAP, 1540 DIA. OUTRIGGER LEG	089710	4
2	BUMPER, GRENE 70 3201 0010. SHR RUBBER	094969	2
3	FOOT ASSEMBLY, TABLE LEG	099281-1	4
4	FRAME WELDMENT, CROSS RETURN TABLE	099652-1	1
	TOP, 63.5X600 CROSS RETURN TABLE - COMPLETE	099656	1
5	ROLLER, 63.5/20X600/608/626 s=14 (EE15)	089044-1	9
6	BRACKET, 63.5X600 ROLLER MOUNTING	099649-1	1
7	PLATE, 63.5/20X600 ROLLER CLAMP	099650-1	2
8	BOLT, M8x25-8.8-B HEX HEAD FULL THREAD ZINC	F81002-5	4
9	BOLT, M10x80-8.8 HEX HEAD ZINC	F81003-50	4
10	NUT, M8-8-B HEX NYLON ZINC LOCK	F81032-2	4
11	NUT, M10-8-B HEX NYLON ZINC LOCK	F81033-1	4
12	WASHER, 8.4 FLAT ZINC	F81054-1	8
13	WASHER, 10.5 FLAT ZINC	F81055-1	8

**REPLACEMENT PARTS***Cross Roller Table, SLPCRT***1**

	ARM, OPENED W/RP-90 ROLLERS - COMPLETE	099679	1	
14	KNOB, PLASTIC CRANK HANDLE	086338	2	
	M16 BOLTS +2 NUTS	093710	2	
15	NUT, M16-5-B HEX	F81036-5	1	
16	BOLT, M16 BED RAIL ADJUSTMENT	086809	2	
17	BEARING, UCFL204 (COMPLEX) W/HOUSING	500060	2	
18	BUSHING, 21X30X10 ZINC-PLATED SPACER	099351-1	12	
19	ARM WELDMENT, OPENED	099680-1	1	
20	ROLLER, RP-90. 6304 POLYURETHANE	099689	12	
21	BOLT, M12x40-8.8 HEX HEAD ZINC	F81004-1	4	
22	BOLT, M20X100-8.8 HEX HEAD ZINC	F81007-6	2	
23	BOLT, M20X60-8.8 HEX HEAD ZINC	F81007-7	10	
24	NUT, M10-8-B HEX NYLON ZINC LOCK	F81033-1	2	
25	NUT, M12-8 HEX NYLON ZINC LOCK	F81034-2	4	
26	NUT, M20-8-A HEX NYLON ZINC LOCK	F81037-2	12	
27	WASHER, 13 FLAT ZINC	F81056-1	8	
28	WASHER, 17 FLAT ZINC	F81058-1	8	
29	WASHER, 21 FLAT ZINC	F81059-2	24	
30	PIN, 45308DNW DETENT	089939	2	
31	PLATE, OPENED ARM LOCK	503336-1	2	
32	CAP, 80x40 TUBE	099692	2	
33	BOLT, M8x65 8.8 HEX HEAD FULL THREAD ZINC	F81002-9	4	
34	NUT, M8-8-B HEX NYLON ZINC LOCK	F81032-2	4	
35	NUT, M16-5.8 HEX ZINC	F81036-1	8	
36	WASHER, 8.4 FLAT ZINC	F81054-1	8	
37	WASHER, 17 FLAT ZINC	F81058-1	8	

# 1 REPLACEMENT PARTS

## Control Box

### 1.34 Control Box

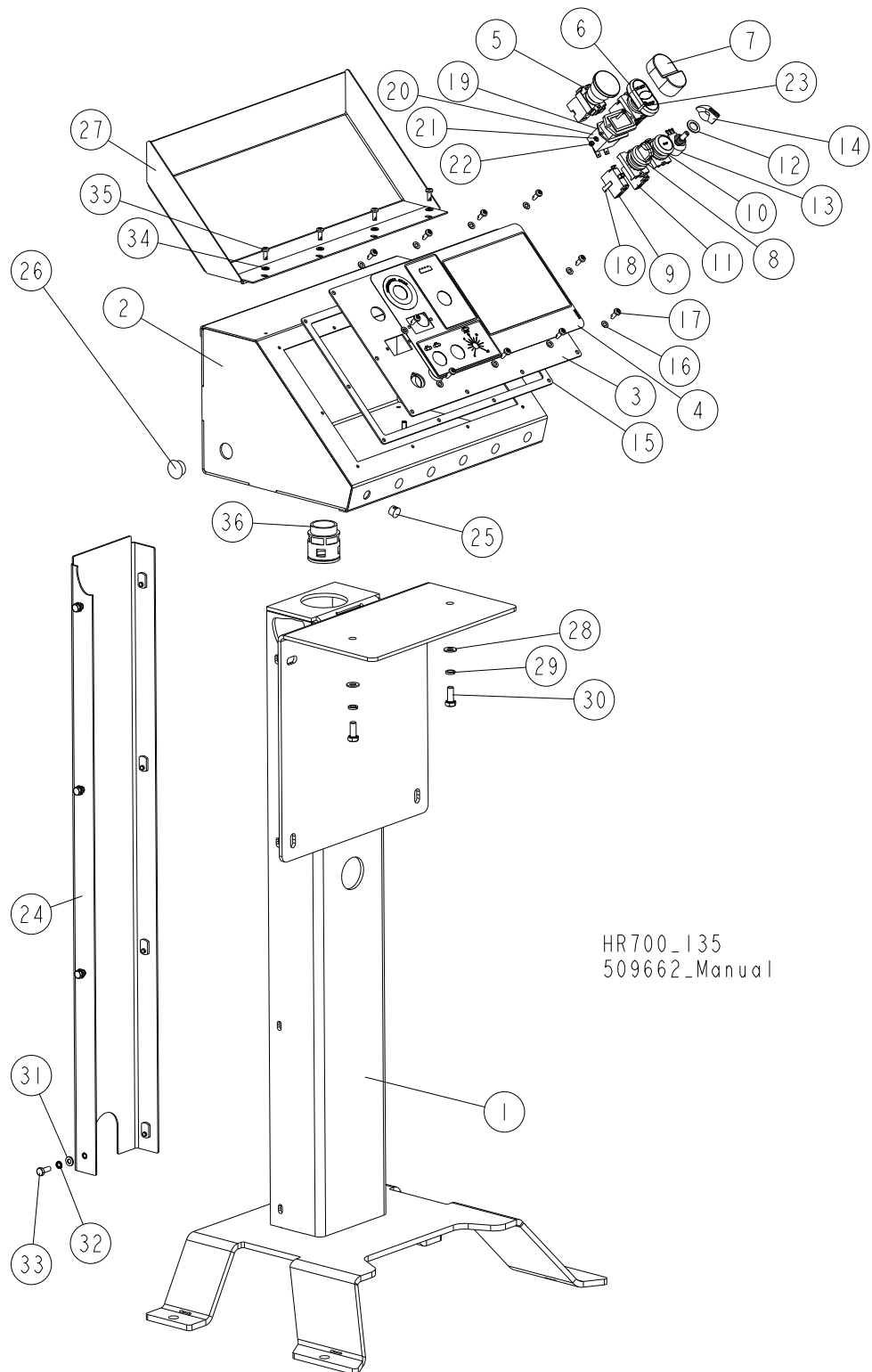

HR700\_135  
509662\_Manual

REF.	DESCRIPTION (◆ Indicates Parts Available In Assemblies Only)	PART #	QTY
	<b>BOX, HR500/700 CONTROL - COMPLETE</b>	<b>515180</b>	<b>1</b>
<b>1</b>	PEDESTAL, CONTROL BOX	505555-1	1

# REPLACEMENT PARTS

Control Box

1

REF.	DESCRIPTION (◆ Indicates Parts Available In Assemblies Only)	PART #	QTY
2	BOX WELDMENT, TVS CONTROL	510061-1	1
	PANEL ASSEMBLY, HR500/700 CONTROL BOX FRONT	511804	1
3	PANEL, HR500/700 CONTROL BOX FRONT	511803-1	1
4	DECAL, HR500/700 CONTROL BOX	510765	1
5	BUTTON, XB4 BS542 EMERGENCY STOP	086556	1
6	SWITCH, 24V ILLUMINATED MOELLER START/STOP	090452	1
7	DIAPHRAGM, M22-T-DD MOELLER ACTUATOR	090462	1
8	SWITCH, MOELLER 3-POSITION GREEN	091359	1
9	ELEMENT, M22 K10 MOELLER CONTACT	091362	1
10	SWITCH, M22 RED PUSHBUTTON	090926	1
11	ELEMENT, M22 K10 MOELLER CONTACT	091362	1
12	WASHER, 1/2X3/4X1/16 NYLON	P05251-1	1
13	POTENTIOMETER, 5K 53C35K	504389	1
14	KNOB, SPEED CONTROL	P06257	1
15	GASKET, CONTROL BOX	097132	1
16	WASHER, 5.3 FLAT ZINC	F81052-1	10
17	BOLT, #10-24X1/2 PAN HEAD, TYPE 23	F05015-17	10
18	ADAPTOR, M22-XC-Y CODING	092687	2
19	GASKET, HOUR METER	093346	1
20	METER, (HOBBS-HONEYWELL) HOUR	093166	1
21	WASHER, 3.2 FLAT ZINC	F81050-2	2
22	NUT, M3-6 HEX NYLON ZINC LOCK	F81028-2	2
23	SCREW, M3x16 5.8-B CROSS RECESSED PAN HEAD ZINC	F81028-3	2
24	PLATE, WM1000 REAR CONTROL BOX PEDESTAL	504499-1	1
25	CAP, HEYMAN DP-812 12.7 HOLE	086773	6
26	CAP, SR1086 22.2 HOLE	093544	2
27	COVER, CONTROL BOX - COMPLETE	097135-1	1
28	WASHER, 8.4 FLAT ZINC	F81054-1	2
29	WASHER, 8.2 SPLIT LOCK ZINC	F81054-4	2
30	BOLT, M8X20 8.8 HEX HEAD FULL THREAD ZINC	F81002-4	2
31	WASHER, 6.4 FLAT ZINC	F81053-1	8
32	WASHER, Z6.1 SPLIT LOCK ZINC	F81053-3	8
33	BOLT, M6X16-8.8 HEX HEAD FULL THREAD ZINC	F81001-15	8
34	WASHER, 5.3 FLAT ZINC	F81052-1	4
35	BOLT, #10-24X1/2 PAN HEAD, TYPE 23	F05015-17	4
36	GLAND, KCLICK-GP29 RILL 29 CONDUIT	086576	1

# 1 REPLACEMENT PARTS

Multisetwork

## 1.35 Multisetwork

511869\_001  
511869\_Manual

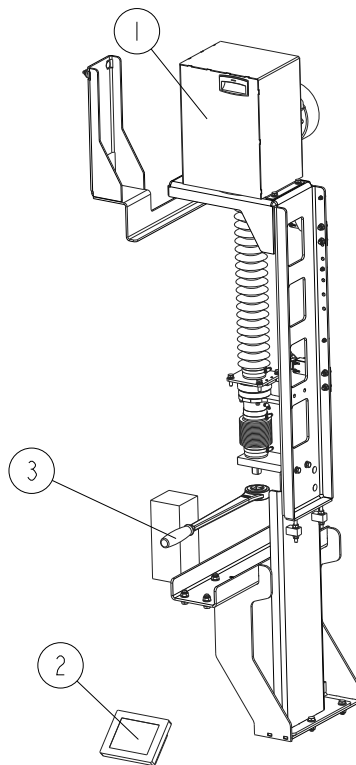

REF.	DESCRIPTION (◆ Indicates Parts Available In Assemblies Only)	PART #	QTY					
	MULTISETWORK, HR700-1	511869	x	-	-	-	-	-
	MULTISETWORK, HR700-2	511870	-	x	-	-	-	-
	MULTISETWORK, HR700-3	511871	-	-	x	-	-	-
	MULTISETWORK, HR700-4	511872	-	-	-	x	-	-
	MULTISETWORK, HR700-5	511873	-	-	-	-	x	-
	MULTISETWORK, HR700-6	511874	-	-	-	-	-	x
1	DRIVE ASSEMBLY, HR700 UP/DOWN <a href="#">See Section 1.36</a>	515140	1	2	3	4	5	6
2	SCREEN, HMISTU855 TOUCH	508978	1	1	1	1	1	1
3	WRENCH, 3/4" RATCHET	507312	1	1	1	1	1	1



1.36 Up/Down Drive Assembly, HR700 (Optional)

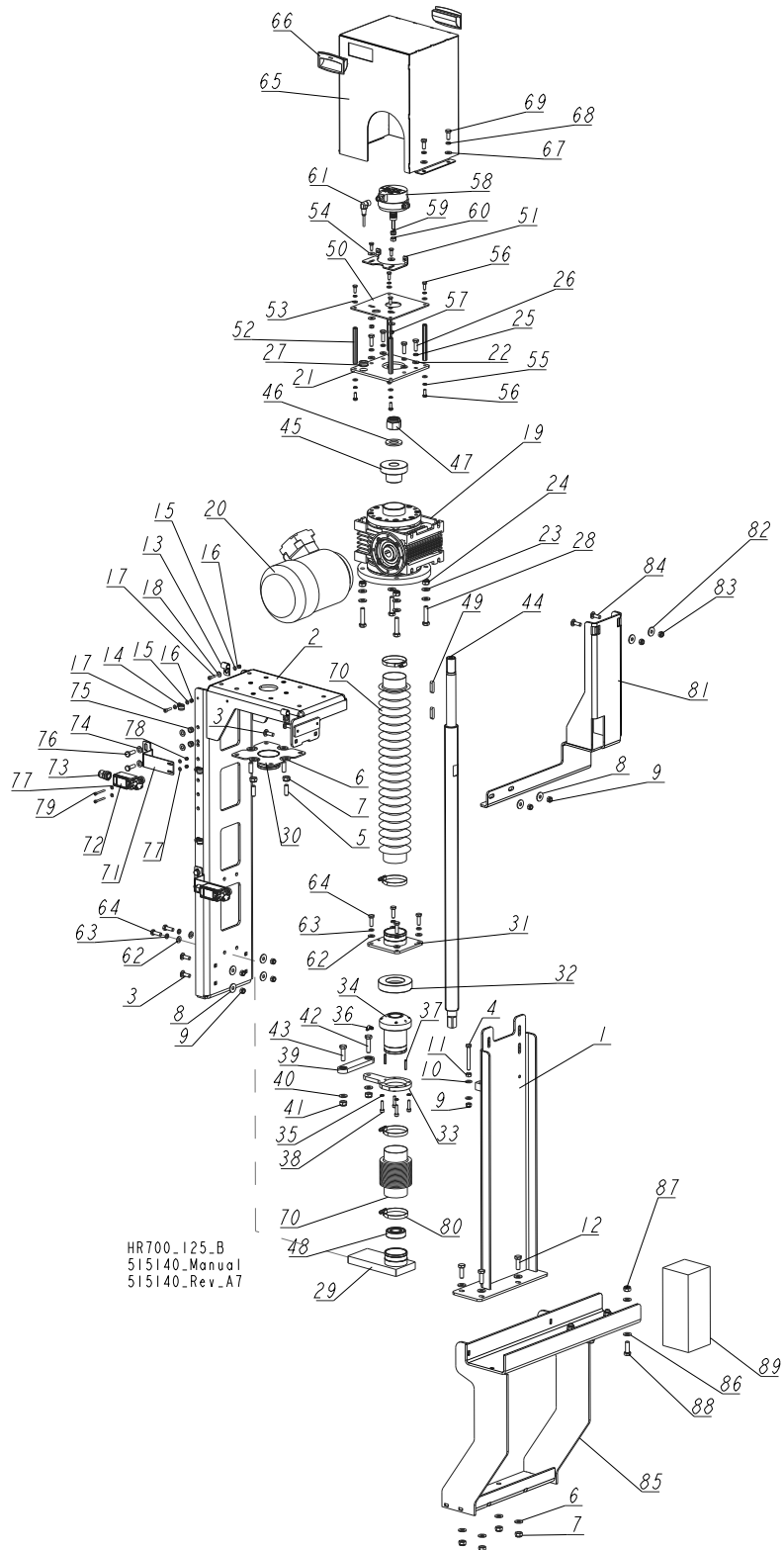

# 1

## REPLACEMENT PARTS

*Up/Down Drive Assembly, HR700 (Optional)*

REF.	DESCRIPTION (◆ Indicates Parts Available In Assemblies Only)	PART #	QTY
	<b>DRIVE ASSEMBLY, HR700 UP/DOWN SCREW</b>	<b>515140</b>	<b>1</b>
	<b>BRACKET, HR700 UP/DOWN DRIVE SUPPORT - COMPLETE</b>	<b>515139</b>	<b>1</b>
1	BRACKET, HR700 UP/DOWN DRIVE SUPPORT - LOWER	514911-1	1
2	BRACKET, HR700/SHS UP/DOWN DRIVE SUPPORT - UPPER	515155-1	1
3	BOLT, M8X25-8.8 CARRIAGE HEAD ZINC	F81002-59	6
4	BOLT, M8X65 8.8 HEX HEAD FULL THREAD ZINC	F81002-9	2
5	SCREW, M10X30-33H-GEOMET SET	F81003-35	4
6	WASHER, 10.5 FLAT ZINC	F81055-1	12
7	NUT, M10-8-B HEX NYLON ZINC LOCK	F81033-1	8
8	WASHER, ISO 7093-1-8-200 HV-A2E	F81054-11	6
9	NUT, M8-8-B HEX NYLON ZINC LOCK	F81032-2	8
10	WASHER, 8.4 FLAT ZINC	F81054-1	4
11	NUT, M8-8-B HEX ZINC	F81032-1	2
12	BOLT, M10X30 5.8 HEX HEAD FULL THREAD ZINC	F81003-2	4
13	CLAMP, 1/2" EMT COATED	P07584	2
14	CLAMP, RSGU 1.10/12W1 METAL & RUBBER	086861	3
15	WASHER, 5.3 FLAT ZINC	F81052-1	8
16	NUT, M5-8 DIN985 ZINC-PLATED	F81030-2	5
17	SCREW, M5X20 8.8 HEX SOCKET HEAD CAP ZINC	F81000-72	5
18	WASHER, 5.5 SPECIAL FLAT ZINC	F81052-3	2
	<b>REDUCER, MRP-63 SHS/HR700 UP/DOWN DRIVE - COMPLETE</b>	<b>515157</b>	<b>1</b>
	<b>REDUCER, MRP-63/16[0.75-1400-120/19]-WMI-[S3=60%]-B/SO/K2/B6</b>	<b>514932</b>	<b>1</b>
19	REDUCER, MRP-63/16 [120/19]SO/K2/B6	514933	1
20	MOTOR, SKH 80-4B2/3045 (N=0.75 kW, N=1380 r.p.m.) INDUCTION	514934	1
21	PLATE, ENCODER MOUNT	515149-1	1
22	WASHER, 8.4 FLAT ZINC	F81054-1	4
23	WASHER, 10.5 FLAT ZINC	F81055-1	8
24	NUT, M10-8-B HEX NYLON ZINC LOCK	F81033-1	4
25	WASHER, 8.2 SPLIT LOCK ZINC	F81054-4	4
26	BOLT, M8X25-8.8-B HEX HEAD FULL THREAD ZINC	F81002-5	4
27	GROMMET, 20/13 RUBBER	086188	1
28	BOLT, M10X45 HEX HEAD FULL THREAD ZINC	F81003-3	4
29	BRACKET, UP/DOWN SCREW BELLOWS - LOWER	514935-1	1
30	BRACKET, UP/DOWN SCREW BELLOWS - UPPER	514915-1	1
31	BRACKET, UP/DOWN SCREW BELLOWS - MIDDLE	514919-1	1
32	WASHER, 90X50X20 SPHERICAL ZINC-PLATED SEAT	514898-1	1
	<b>NUT, TR36X3 UP/DOWN SCREW - COMPLETE</b>	<b>515138</b>	<b>1</b>
33	PLATE, TR36X3 NUT SEAT	515143-1	1
34	NUT, TR36X3 ACME SCREW	514899	1
35	WASHER, Z6.1 SPLIT LOCK ZINC	F81053-3	4
36	FITTING, M6 PN/M-86003 GREASE	094213	1
37	PIN, 5X26 ROLL ZINC	F81044-2	2
38	SCREW, M6X25-8.8 HEX SOCKET HEAD CAP ZINC	F81001-41	4
39	LINK, SBPL 10104 PIVOTAL (COMPLEX)	097700	1
40	WASHER, 10.5 FLAT ZINC	F81055-1	2

# REPLACEMENT PARTS

Up/Down Drive Assembly, HR700 (Optional)

1

REF.	DESCRIPTION (◆ Indicates Parts Available In Assemblies Only)	PART #	QTY
41	NUT, M10-8-B HEX NYLON ZINC LOCK	F81033-1	2
42	BOLT, M10X40-8.8 HEX HEAD FULL THREAD ZINC	F81003-16	1
43	BOLT, M10X35 8.8 HEX HEAD FULL THREAD ZINC	F81003-17	1
44	SCREW, TR36X3 ACME ZINC-PLATED	515145-1	1
45	CAP, MRP-63 MOTOREDUCER ZINC-PLATED	515144-1	1
46	WASHER, 25 FLAT ZINC	F81061-3	1
47	NUT, M24X2 PN-EN ISO 7040 NYLON	F81039-10	1
48	BEARING, 6205 2RSR P6 (FAG,NSK,SKF) BALL	087353	1
49	KEY, A8X7X32 PARALLEL	088564	2
	<b>ENCODER ASSEMBLY, SHS/HR700</b>	<b>515147</b>	<b>1</b>
50	PLATE, ENCODER MOUNT	515148-1	1
51	BRACKET, ENCODER	507372-1	1
52	SPACER, M6X100- BN3319 (BOSSARD)	F81031-10	4
53	WASHER, 6.4 FLAT ZINC	F81053-1	8
54	WASHER, 6.5 SPECIAL FLAT ZINC	F81053-11	4
55	WASHER, Z 6.1 SPLIT LOCK ZINC	F81053-3	8
56	BOLT, M6X16-8.8 HEX HEAD FULL THREAD ZINC	F81001-15	10
57	NUT, M6-8-B HEX NYLON ZINC LOCK	F81031-2	2
58	ENCODER, 48 IMP./TURN 12V DC INCREMENTAL	510285	1
59	NUT, M8 8 HEX NYLON ZINC LOCK	F81032-2	1
60	NUT, M8-8-B HEX ZINC	F81032-1	1
61	CABLE, 5M LIMIT SWITCH	087652	1
62	WASHER, 8.4 FLAT ZINC	F81054-1	6
63	WASHER, 8.2 SPLIT LOCK ZINC	F81054-4	7
64	BOLT, M8X25-8.8-B HEX HEAD FULL THREAD ZINC	F81002-5	6
	<b>GUARD, SHS/HR700 UP/DOWN DRIVE - COMPLETE</b>	<b>515151</b>	<b>1</b>
65	GUARD, SHS/HR700 UP/DOWN DRIVE	515152-1	1
66	HANDLE, EPR.90-PF-C1(261051-C1) SNAP-IN FLUSH PULL	100012	2
67	WASHER, 8.4 FLAT ZINC	F81054-1	4
68	WASHER, 8.2 SPLIT LOCK ZINC	F81054-4	4
69	BOLT, M8X20 8.8 HEX HEAD FULL THREAD ZINC	F81002-4	4
70	BELLOWS, 60/520 PROTECTIVE	514918	2
	<b>LIMIT SWITCH ASSEMBLY</b>	<b>515141</b>	<b>2</b>
71	BRACKET, LIMIT SWITCH MOUNT	515142-1	1
72	SWITCH, GLCB01A1B LIMIT	100931	1
73	GLAND, DP9/H CABLE	F81096-2	1
74	WASHER, 8.4 FLAT ZINC	F81054-1	4
75	NUT, M8 8 HEX NYLON ZINC LOCK	F81032-2	2
76	BOLT, M8X25-8.8-B HEX HEAD FULL THREAD ZINC	F81002-5	2
77	WASHER, 4.3 FLAT ZINC	F81051-2	4
78	NUT, M4-8 HEX NYLON ZINC LOCK	F81029-1	2
79	SCREW, M4X35 8.8 HEX SOCKET HEAD CAP ZINC	F81011-34	2
80	CLAMP, 50-70 DIN 3017 WORM	F81095-6	4
	<b>BRACKET ASSEMBLY, HR700 UP/DOWN DRIVE TRANSPORT - UPPER</b>	<b>515163</b>	<b>1</b>
81	BRACKET, HR700 UP/DOWN DRIVE TRANSPORT - UPPER	515164-1	1

**1****REPLACEMENT PARTS***Up/Down Drive Assembly, HR700 (Optional)*

REF.	DESCRIPTION (◆ Indicates Parts Available In Assemblies Only)	PART #	QTY	
82	WASHER, ISO 7093-1-8-200 HV-A2E	F81054-11	2	
83	NUT, M8-8-B HEX NYLON ZINC LOCK	F81032-2	2	
84	BOLT, M8X25-8.8 CARRIAGE HEAD ZINC	F81002-59	2	
	<b>BRACKET ASSEMBLY, HR700 UP/DOWN DRIVE TRANSPORT - LOWER</b>	<b>515159</b>	<b>1</b>	
85	BRACKET, HR700 UP/DOWN DRIVE TRANSPORT - LOWER	515160-1	1	
86	WASHER, 10.5 FLAT ZINC	F81055-1	8	
87	NUT, M10-8-B HEX NYLON ZINC LOCK	F81033-1	4	
88	BOLT, M10X30 5.8 HEX HEAD FULL THREAD ZINC	F81003-2	4	
89	BLOCK, HR700 SAW HEAD TRANSPORT SUPPORT	514382	1	

1.37 Single Blade Tension Assembly (Optional for non-CE Markets)

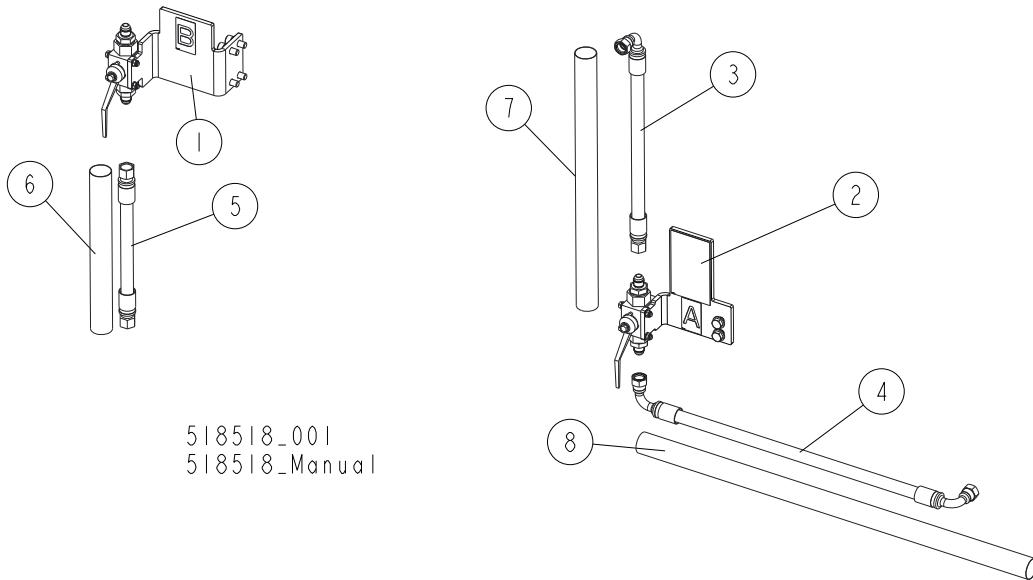

REF.	DESCRIPTION (◆ Indicates Parts Available In Assemblies Only)	PART #	QTY
	<b>SINGLE BLADE TENSION ASSEMBLY (HR500/700, USA)</b>	<b>518518</b>	<b>1</b>
1	VALVE, OIL FLOW CONTROL - COMPLETE (FOR SECOND SAW HEAD) <a href="#">See Section 1.39</a>	518515	1
2	VALVE, OIL FLOW CONTROL - COMPLETE (FOR FIRST SAW HEAD) <a href="#">See Section 1.38</a>	518516	1
3	HOSE, PHD 2T3/8X0.27 90W9/16UNF-W9/16UNF HYDRAULIC	506736	1
4	HOSE, PHD 2T3/8X0.43 90W9/16UNF-90W9/16UNF HYDRAULIC	506737	1
5	HOSE, PHD 2T3/8X0.45 W9/16UNF-W9/16UNF HYDRAULIC	518552	1
6	SLEEVE, VERTICAL HOSE PROTECTION	098489	1
7	SLEEVE, VERTICAL HOSE PROTECTION	508713	1
8	SLEEVE, OBLIQUE HOSE PROTECTION	508714	1

# 1 REPLACEMENT PARTS

## Oil Flow Control Valve (Optional for First Saw Head)

### 1.38 Oil Flow Control Valve (Optional for First Saw Head)

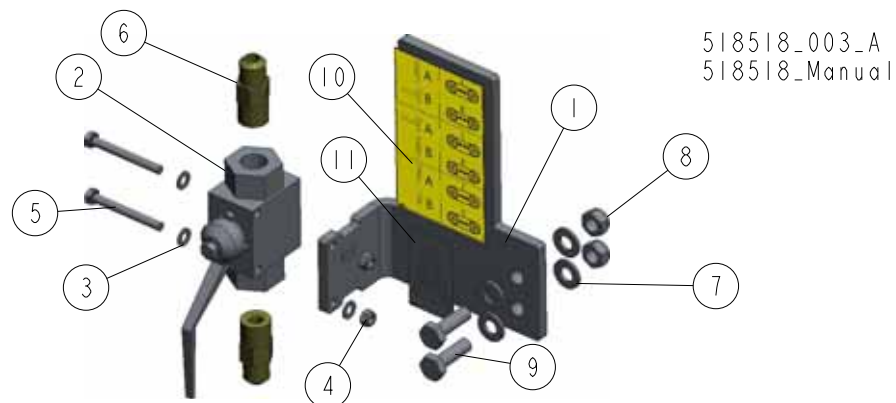

REF.	DESCRIPTION (◆ Indicates Parts Available In Assemblies Only)	PART #	QTY
	<b>VALVE, OIL FLOW CONTROL - COMPLETE (FOR FIRST SAW HEAD)</b>	<b>518516</b>	<b>1</b>
1	BRACKET, RSAP2V02FF 3/8G VALVE MOUNT	518517-1	1
2	VALVE, PN 500 RSAP2V02FF 3/8" G DN10 BALL	502056	1
3	WASHER, 5.3 FLAT ZINC	F81052-1	4
4	NUT, M5-8 DIN985 ZINC-PLATED	F81030-2	2
5	BOLT, M5x45 DIN933-A2-70 STAINLESS STEEL	F81000-22	2
6	FITTING, BSP-JIC 3/8"-9/16" STRAIGHT	091842	2
7	WASHER, 8.4 FLAT ZINC	F81054-1	4
8	NUT, M8 8 HEX NYLON ZINC LOCK	F81032-2	2
9	BOLT, M8x25-8.8-B HEX HEAD FULL THREAD ZINC	F81002-5	2
10	DECAL, SINGLE BLADE TENSION ASSEMBLY	518900 <sup>1</sup>	1
11	DECAL A, SINGLE BLADE TENSION ASSEMBLY	518901 <sup>1</sup>	1

<sup>1</sup> Decals belongs to 520500 decals kit.

**1.39 Oil Flow Control Valve (Optional for Second Saw Head)**

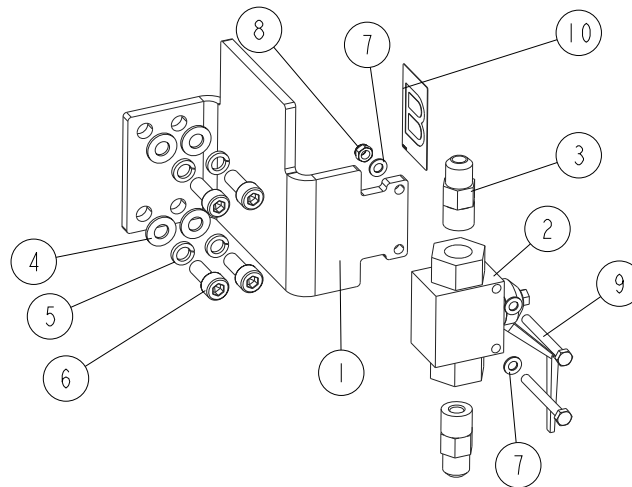

518518\_002\_A  
518518\_Manual

REF.	DESCRIPTION (◆ Indicates Parts Available In Assemblies Only)	PART #	QTY
	<b>VALVE, OIL FLOW CONTROL - COMPLETE (FOR SECOND SAW HEAD)</b>	<b>518515</b>	<b>1</b>
1	BRACKET, RSAP2VO2FF G3/8 VALVE MOUNT	518840-1	1
2	VALVE, PN 500 RSAP2V02FF 3/8" G DN10 BALL	502056	1
3	FITTING, BSP-JIC 3/8"-9/16" STRAIGHT	091842	2
4	WASHER, 8.4 FLAT ZINC	F81054-1	4
5	WASHER, 8.2 SPLIT LOCK ZINC	F81054-4	4
6	SCREW, M8x20-8.8 HEX SOCKET HEAD CAP ZINC	F81002-30	4
7	WASHER, 5.3 FLAT ZINC	F81052-1	4
8	NUT, M5-8 DIN985 ZINC-PLATED	F81030-2	2
9	BOLT, M5x45 DIN933-A2-70 STAINLESS STEEL	F81000-22	2
10	DECAL B, SINGLE BLADE TENSION ASSEMBLY	518902 <sup>1</sup>	1

<sup>1</sup> Decal belongs to 520500 decals kit.

# 1 REPLACEMENT PARTS

## Ground Cable

### 1.40 Ground Cable

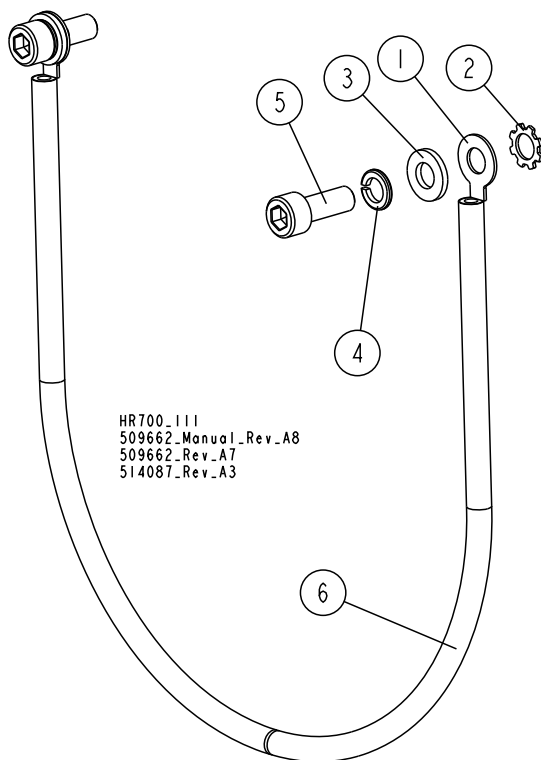

REF.	DESCRIPTION (◆ Indicates Parts Available In Assemblies Only)	PART #	QTY
	<b>CABLE, COMPLETE GROUND</b>	<b>514087</b>	<b>1</b>
1	TERMINAL, 1/4 14-16GA RING NI LOOSE	F81065-1	2
2	WASHER, 6.4 FE/ZN5 SERRATED LOCK EXTERNAL TEETH	F81053-2	2
3	WASHER, 6.4 FLAT ZINC	F81053-1	2
4	WASHER, Z 6.1 SPLIT LOCK	F81053-3	2
5	SCREW, M6X16 8.8 HEX SOCKET HEAD CAP ZINC	F81001-21	2
6	CABLE, GROUND	R80587-3_400	1



1.41 Electric Boxes

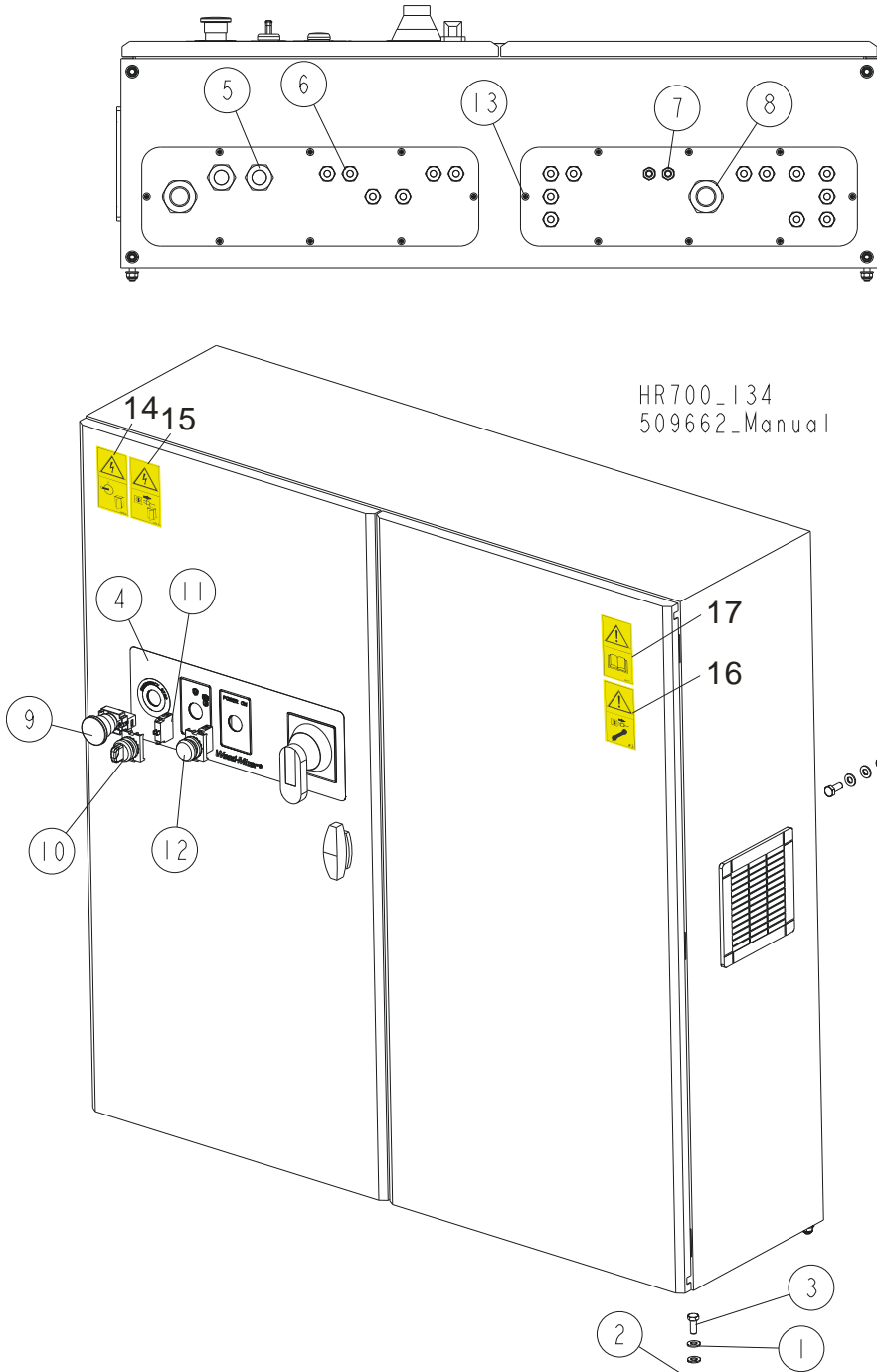

REF.	DESCRIPTION (◆ Indicates Parts Available In Assemblies Only)	PART #	QTY
1	WASHER, 8.4 FLAT ZINC	F81054-1	12
2	NUT, M8 8 HEX NYLON ZINC LOCK	F81032-2	6
3	BOLT, M8X20 8.8 HEX HEAD FULL THREAD ZINC	F81002-4	6
	BOX, 1000X1000X300 HR500-2/HR700-2 ELECTRIC	515221	1/0/0/0/0
	BOX, 1000X1000X300 HR500-2/HR700-2 ELECTRIC	515222	0/1/0/0/0
	BOX, 1000X1000X300 HR500-2/HR700-2 ELECTRIC	515223	0/0/1/0/0

# 1

## REPLACEMENT PARTS

### *Electric Boxes*

REF.	DESCRIPTION (◆ Indicates Parts Available In Assemblies Only)	PART #	QTY
	<b>BOX, 1000X1000X300 HR500-2/HR700-2 ELECTRIC</b>	<b>515224</b>	<b>0/0/0/1/0/0</b>
	<b>BOX, 1000X1000X300 HR500-2/HR700-2 ELECTRIC</b>	<b>515225</b>	<b>0/0/0/0/1/0</b>
	<b>BOX, 1000X1000X300 HR500-2/HR700-2 ELECTRIC</b>	<b>515226</b>	<b>0/0/0/0/0/1</b>
4	DECAL, 1000X1000X300 HR500/700 ELECTRIC BOX	515227	1
5	GLAND, DP21/H CABLE	F81096-3	1/2/3/4/5/6
6	GLAND, DP9/H CABLE	F81096-2	11/17/23/27/33/38
7	GLAND, DP 7/H CABLE	F81096-11	1/2/3/4/5/6
8	GLAND, PG29 CABLE	F81096-1	2
9	BUTTON, XB4 BS542 EMERGENCY STOP	086556	1
10	SWITCH, 3-POSITION MOELLER GREEN	091359	1
11	ELEMENT, M22 K10 MOELLER CONTACT	091362	1
12	LIGHT, 1SFA619402L5415 WHITE CONTROL	509129	1
13	BOLT, #10-24X1/2 PH PAN HEAD, TYPE 23	F05015-17	16
14	<b>DECAL, HAZARDOUS VOLTAGE INSIDE THE ELECTRIC BOX (PICTOGRAM)</b>	<b>096316</b>	<b>1</b>
15	<b>DECAL, REMOVE THE PLUG BEFORE OPENING THE ELECTRIC BOX (PICTOGRAM)</b>	<b>096319</b>	<b>1</b>
16	<b>DECAL, DISCONNECT POWER SUPPLY BEFORE SERVICING (PICTOGRAM)</b>	<b>098177</b>	<b>1</b>
17	<b>DECAL, READ THE OPERATOR'S MANUAL (PICTOGRAM)</b>	<b>096317</b>	<b>1</b>

## SECTION 2 SIDE FENCE (CE VERSION ONLY)

### 2.1 Side Fence

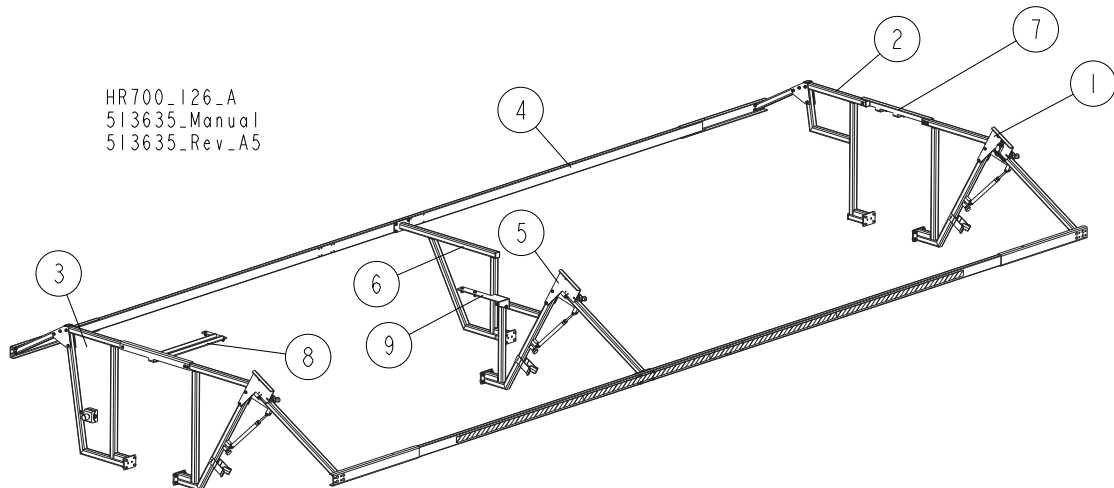

REF.	DESCRIPTION (◆ Indicates Parts Available In Assemblies Only)	PART#	QTY
	<b>FENCE, HR700-1/HR700-2 SIDE - COMPLETE</b>	<b>513633</b>	<b>1/0/0</b>
	<b>FENCE, HR700-3/HR700-4 SIDE - COMPLETE</b>	<b>513634</b>	<b>0/1/0</b>
	<b>FENCE, HR700-5/HR700-6 SIDE - COMPLETE</b>	<b>513635</b>	<b>0/0/1</b>
1	BRACKET, MOVING SIDE FENCE SUPPORT - COMPLETE <a href="#">See Section 2.2</a>	514229	2
2	BRACKET, FIXED SIDE FENCE SUPPORT - COMPLETE <a href="#">See Section 2.3</a>	515211	1
3	BRACKET, FIXED SIDE FENCE SUPPORT - COMPLETE <a href="#">See Section 2.4</a>	514365	1
4	BARRIER, HR700-1/HR700-2 SIDE FENCE - COMPLETE <a href="#">See Section 2.6</a>	514367	2/0/0
	BARRIER, HR700-3/HR700-4 SIDE FENCE - COMPLETE <a href="#">See Section 2.6</a>	514366	0/2/0
	BARRIER, HR700-5/HR700-6 SIDE FENCE - COMPLETE <a href="#">See Section 2.6</a>	514215	0/0/2
5	BRACKET, MOVING SIDE FENCE MIDDLE SUPPORT - COMPLETE <a href="#">See Section 2.5</a>	515197	0/0/1
6	BRACKET, FIXED SIDE FENCE MIDDLE SUPPORT - COMPLETE <a href="#">See Section 2.5</a>	515216	0/0/1
7	BRACKET, FENCE FRONT CONNECTION - COMPLETE <a href="#">See Section 2.3</a>	514209	1
8	BRACKET, FENCE REAR CONNECTION - COMPLETE <a href="#">See Section 2.4</a>	514213	1
9	PLATE, MIDDLE SUPPORT BRACKET CONNECTION - COMPLETE <a href="#">See Section 2.5</a>	515201	0/0/1

# 2

## Side Fence (CE Version Only)

### Moving Side Fence Support Bracket

## 2.2 Moving Side Fence Support Bracket

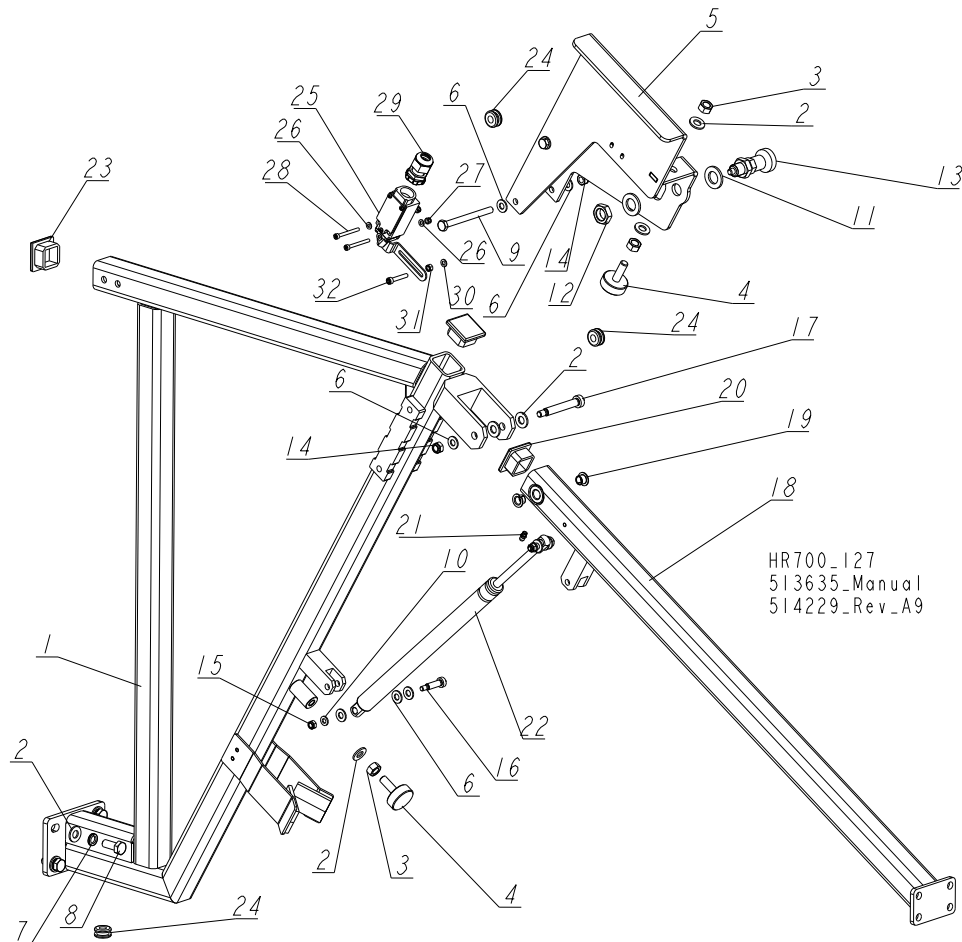

REF.	DESCRIPTION (◆ Indicates Parts Available In Assemblies Only)	PART#	QTY
	<b>BRACKET, MOVING SIDE FENCE SUPPORT - COMPLETE</b>	<b>514229</b>	<b>1</b>
1	BRACKET WELDMENT, MOVING SIDE FENCE SUPPORT	099450-1	1
2	WASHER, 10.5 FLAT ZINC	F81055-1	10
3	NUT, M10-8-B HEX ZINC	F81033-3	3
4	FOOT, M10	092839	2
5	BRACKET, LIMIT SWITCH MOUNT	099470-1	1
6	WASHER, 8.4 FLAT ZINC	F81054-1	11
7	WASHER, Z10.2 SPLIT LOCK ZINC	F81055-2	4
8	BOLT, M10X25 8.8 HEX HEAD FULL THREAD ZINC	F81003-11	4
9	BOLT, M8X90-8.8 HEX HEAD FULL THREAD ZINC	F81002-16	2
10	WASHER, 6.4 FLAT ZINC	F81053-1	2
11	WASHER, 17 SPLIT LOCK ZINC	F81058-1	2
12	NUT, M16X1.5-08-B THIN ZINC	F81036-6	1
13	PIN, 45308DNW DETENT	089939	1
14	NUT, M8-8-B HEX NYLON ZINC LOCK	F81032-2	3

## Side Fence (CE Version Only)

### Moving Side Fence Support Bracket

2

REF.	DESCRIPTION (◆ Indicates Parts Available In Assemblies Only)	PART#	QTY	
15	NUT, M6-8-B HEX NYLON ZINC LOCK	F81031-2	2	
16	BOLT, 8/M6X25-12.9 ISO 7379 SHOULDER	F81001-47	2	
17	BOLT, 10/M8X60-12.9 ISO7379/BN1359 BOSSARD SHOULDER	F81003-79	1	
	<b>ARM, SIDE FENCE MOVING - COMPLETE</b>	<b>099464</b>	<b>1</b>	
18	ARM, SIDE FENCE MOVING	099465-1	1	
19	BEARING, TUF1 10.090 (CX) SLIDE	099074	2	
20	CAP, 40X40X(3-4) MOSS TUBE END	097480	1	
21	FITTING, M6 STRAIGHT GREASE	086280	1	
22	SPRING, MS10-1-1F-1F-1000-100-460 (EUROTECHNIKA) GAS	099446	1	
23	CAP, 40X40X(3-4) MOSS TUBE END	097480	2	
24	<b>GROMMET, 3/8 ID RUBBER</b>	025248	3	
25	<b>SWITCH, GSCA 01S1 LIMIT</b>	088407	1	
26	<b>WASHER, 4.3 FLAT ZINC</b>	F81051-2	4	
27	<b>NUT, M4-8 HEX NYLON ZINC LOCK</b>	F81029-1	2	
28	<b>SCREW, M4X40 8.8 HEX SOCKET HEAD CAP ZINC</b>	F81011-37	2	
29	<b>GLAND, PG13.5 CABLE</b>	086524	1	
30	<b>WASHER, 5.3 FLAT ZINC</b>	F81052-1	1	
31	<b>NUT, M5-8 HEX ZINC</b>	F81030-1	1	
32	<b>SCREW, M5X30 5.8 HEX SOCKET HEAD CAP ZINC</b>	F81000-71	1	



## Side Fence (CE Version Only)

### Fixed Side Fence Support Bracket & Front Connection Bracket

## 2.3 Fixed Side Fence Support Bracket & Front Connection Bracket

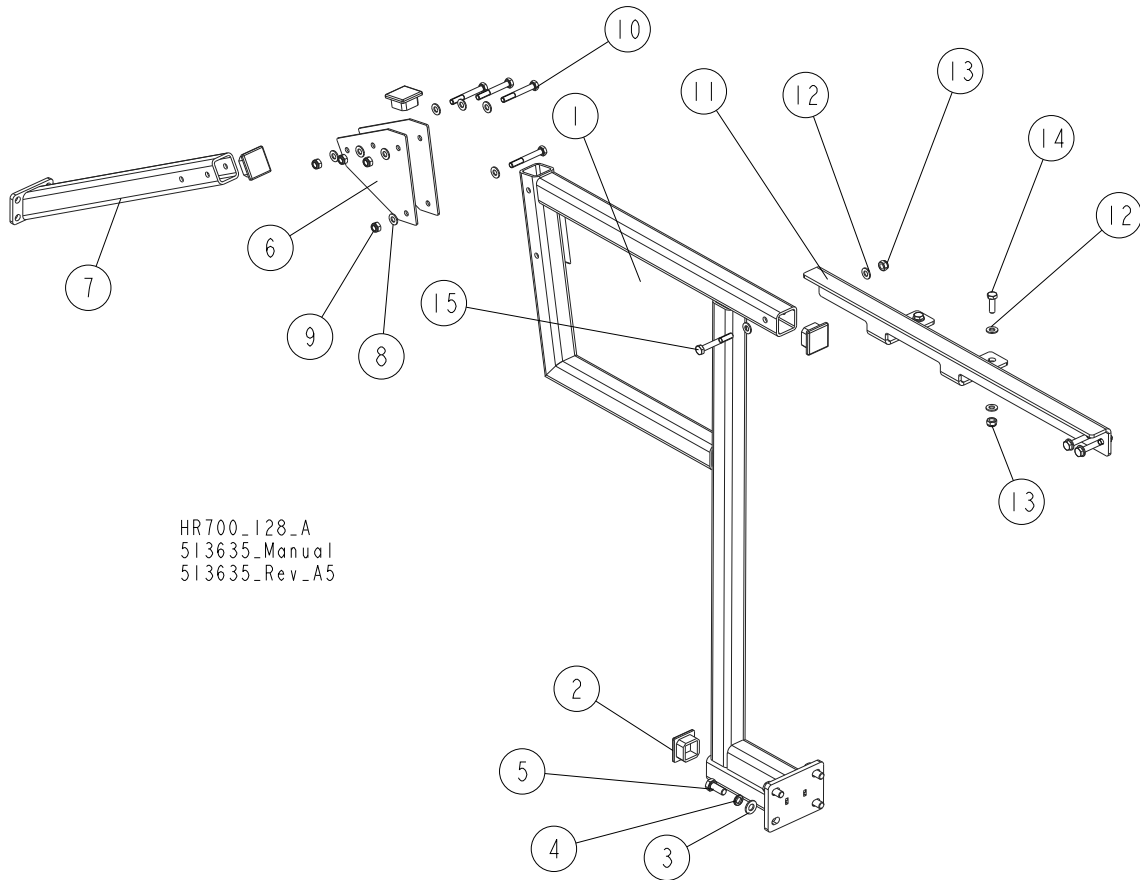

REF.	DESCRIPTION (◆ Indicates Parts Available In Assemblies Only)	PART#	QTY
	<b>BRACKET, FIXED SIDE FENCE SUPPORT - COMPLETE</b>	<b>515211</b>	<b>1</b>
1	BRACKET, FIXED SIDE FENCE SUPPORT	515212-1	1
2	CAP, 40X40X(3-4) MOSS TUBE END	097480	3
3	WASHER, 10.5 FLAT ZINC	F81055-1	4
4	WASHER, Z 10.2 SPLIT LOCK ZINC	F81055-2	4
5	BOLT, M10X25 8.8 HEX HEAD FULL THREAD ZINC	F81003-11	4
6	PLATE, CONNECTING	099462-1	2
7	TUBE WELDMENT, SUPPORT BRACKET	518553-1	1
8	WASHER, 8.4 FLAT ZINC	F81054-1	8
9	NUT, M8-8-B HEX NYLON ZINC LOCK	F81032-2	4
10	BOLT, M8X60-8.8 HEX HEAD ZINC	F81002-54	4
	<b>BRACKET, FENCE FRONT CONNECTION - COMPLETE</b>	<b>514209</b>	<b>1</b>
11	BRACKET, FENCE FRONT CONNECTION	514210-1	1
12	WASHER, 8.4 FLAT ZINC	F81054-1	10
13	NUT, M8 8 HEX NYLON ZINC LOCK	F81032-2	5
14	BOLT, M8X25-8.8-B HEX HEAD FULL THREAD ZINC	F81002-5	2
15	BOLT, M8X60 8.8 HEX HEAD ZINC	F81002-54	3

## 2.4 Fixed Side Fence Support Bracket & Rear Connection Bracket

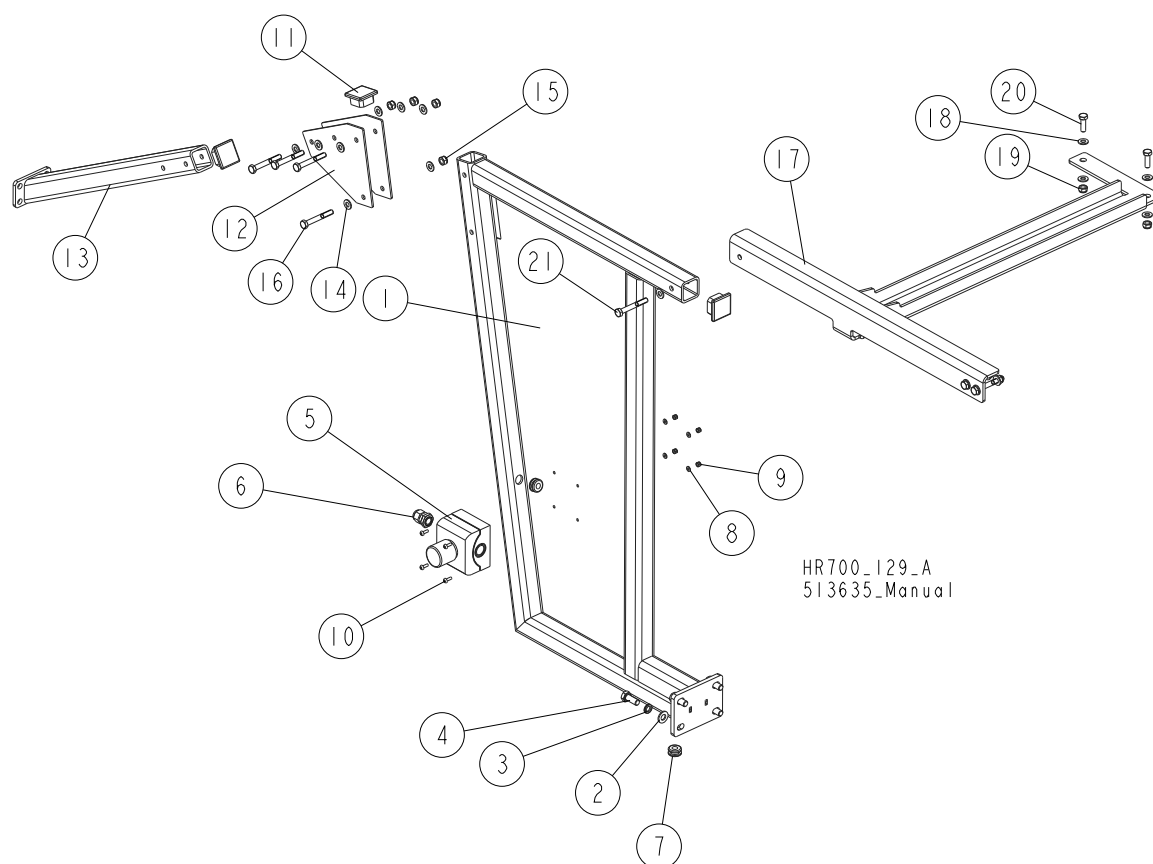

REF.	DESCRIPTION (◆ Indicates Parts Available In Assemblies Only)	PART#	QTY
	<b>BRACKET, FIXED SIDE FENCE SUPPORT - COMPLETE</b>	<b>514365</b>	<b>1</b>
1	BRACKET, FIXED SIDE FENCE SUPPORT	099451-1	1
2	WASHER, 10.5 FLAT ZINC	F81055-1	4
3	WASHER, Z 10.2 SPLIT LOCK ZINC	F81055-2	4
4	BOLT, M10X25 8.8 HEX HEAD FULL THREAD ZINC	F81003-11	4
5	BUTTON, M22-PV/KCO2 EMERGENCY STOP	094726	1
6	GLAND, DP9/H CABLE	F81096-2	1
7	GROMMET, 3/8 ID RUBBER	025248	2
8	WASHER, 4.3 FLAT ZINC	F81051-2	4
9	NUT, M4-8 HEX NYLON ZINC LOCK	F81029-1	4
10	SCREW, M4X12-5.8-B CROSS RECESSED PAN HEAD ZINC	F81011-43	4
11	CAP, 40X40X(3-4) MOSS TUBE END	097480	2
	<b>BRACKET, FENCE REAR CONNECTION - COMPLETE</b>	<b>514213</b>	<b>1</b>
12	BRACKET, FENCE REAR CONNECTION	514214-1	1
13	WASHER, 8.4 FLAT ZINC	F81054-1	10
14	NUT, M8 8 HEX NYLON ZINC LOCK	F81032-2	5
15	BOLT, M8X25-8.8-B HEX HEAD FULL THREAD ZINC	F81002-5	2
16	BOLT, M8X60 8.8 HEX HEAD ZINC	F81002-54	3

## 2 Side Fence (CE Version Only) Middle Support Bracket

### 2.5 Middle Support Bracket

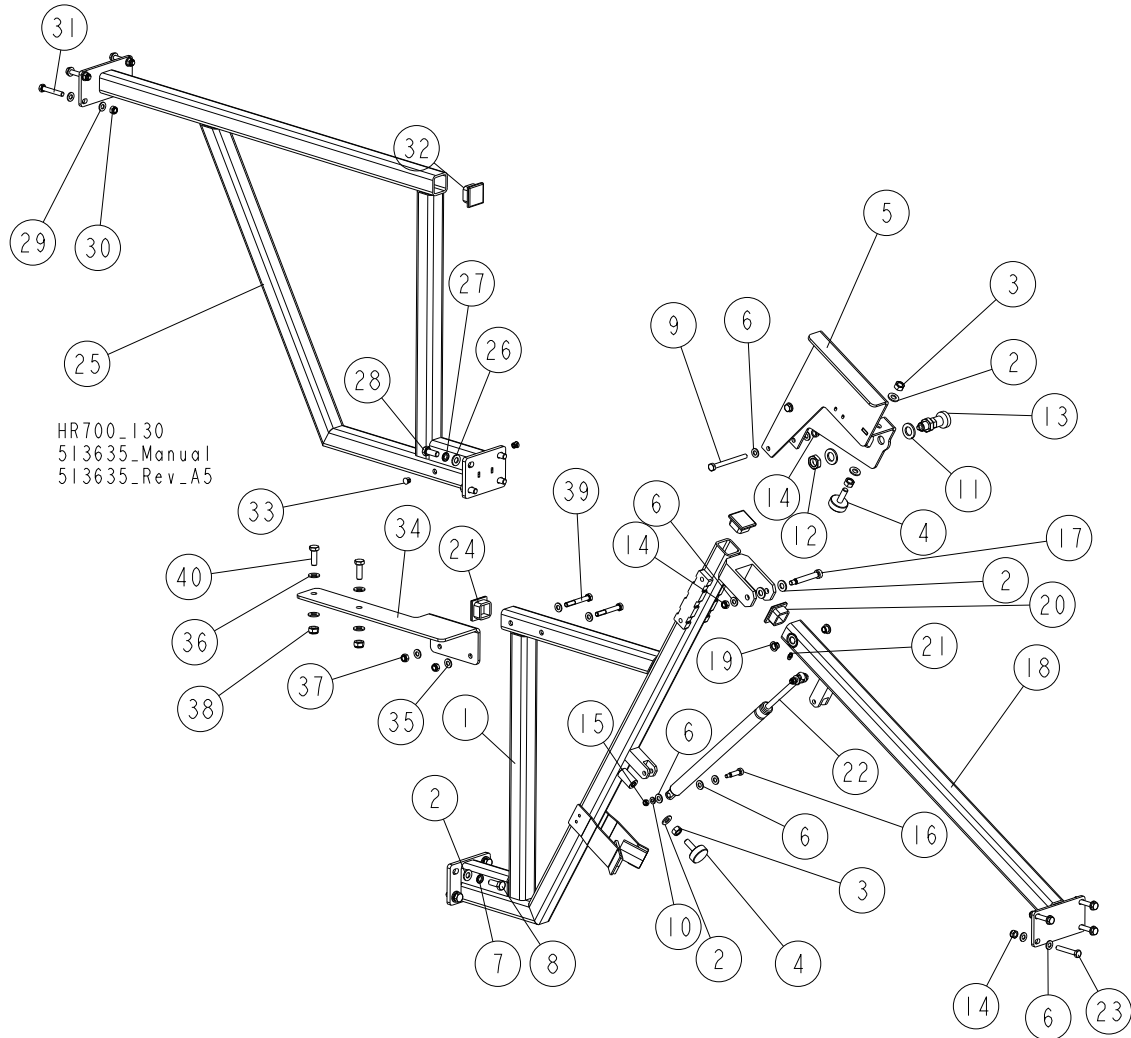

REF.	DESCRIPTION (◆ Indicates Parts Available In Assemblies Only)	PART#	QTY
	<b>BRACKET, MOVING SIDE FENCE MIDDLE SUPPORT - COMPLETE</b>	<b>515197</b>	<b>1</b>
1	BRACKET, MOVING SIDE FENCE MIDDLE SUPPORT	515198-1	1
2	WASHER, 10.5 FLAT ZINC	F81055-1	10
3	NUT, M10-8-B HEX ZINC	F81033-3	3
4	FOOT, M10	092839	2
5	BRACKET, LIMIT SWITCH MOUNT	099470-1	1
6	WASHER, 8.4 FLAT ZINC	F81054-1	19
7	WASHER, Z10.2 SPLIT LOCK ZINC	F81055-2	4
8	BOLT, M10X25 8.8 HEX HEAD FULL THREAD ZINC	F81003-11	4
9	BOLT, M8X90-8.8 HEX HEAD FULL THREAD ZINC	F81002-16	2
10	WASHER, 6.4 FLAT ZINC	F81053-1	2
11	WASHER, 17 SPLIT LOCK ZINC	F81058-1	2
12	NUT, M16X1.5-08-B THIN ZINC	F81036-6	1



REF.	DESCRIPTION (◆ Indicates Parts Available In Assemblies Only)	PART#	QTY	
13	PIN, 45308DNW DETENT	089939	1	
14	NUT, M8-8-B HEX NYLON ZINC LOCK	F81032-2	7	
15	NUT, M6-8-B HEX NYLON ZINC LOCK	F81031-2	2	
16	BOLT, 8/M6X25-12.9 ISO 7379 SHOULDER	F81001-47	2	
17	BOLT, 10/M8X60-12.9 ISO7379/BN1359 BOSSARD SHOULDER	F81003-79	1	
	<b>ARM, MIDDLE MOVING - COMPLETE</b>	<b>515204</b>	<b>1</b>	
18	ARM, MIDDLE MOVING	515205-1	1	
19	BEARING, TUF1 10.090 (CX) SLIDE	099074	2	
20	CAP, 40X40X(3-4) MOSS TUBE END	097480	1	
21	FITTING, M6 GREASE	086280	1	
22	SPRING, MS10-1-1F-1F-1000-100-460 (EUROTECHNIKA) GAS	099446	1	
23	BOLT, M8X50-8.8 HEX HEAD FULL THREAD ZINC	F81002-19	4	
24	CAP, 40X40X(3-4) MOSS TUBE END	097480	2	
	<b>BRACKET, FIXED SIDE FENCE MIDDLE SUPPORT - COMPLETE</b>	<b>515216</b>	<b>1</b>	
25	BRACKET, FIXED SIDE FENCE MIDDLE SUPPORT	515217-1	1	
26	WASHER, 10.5 FLAT ZINC	F81055-1	4	
27	WASHER, Z10.2 SPLIT LOCK ZINC	F81055-2	4	
28	BOLT, M10X25 8.8 HEX HEAD FULL THREAD	F81003-31	4	
29	WASHER, 8.4 FLAT ZINC	F81054-1	8	
30	NUT, M8-8-B HEX NYLON ZINC LOCK	F81032-2	4	
31	BOLT, M8X50-8.8 HEX HEAD FULL THREAD ZINC	F81002-19	4	
32	CAP, 40X40X(3-4) MOSS TUBE END	097480	1	
33	PLUG, SR1086-9.5 #46009 (MOSS) BLANKING	096846	4	
	<b>PLATE, MIDDLE SUPPORT BRACKET CONNECTION - COMPLETE</b>	<b>515201</b>	<b>1</b>	
34	ANGLE, MOUNTING	515220-1	1	
35	WASHER, 8.4 FLAT ZINC	F81054-1	4	
36	WASHER, 10.5 FLAT ZINC	F81055-1	4	
37	NUT, M8-8-B HEX NYLON ZINC LOCK	F81032-2	2	
38	NUT, M10-8-B HEX NYLON ZINC LOCK	F81033-1	2	
39	BOLT, M8X60 8.8 HEX HEAD ZINC	F81002-54	2	
40	BOLT, M10X30 5.8 HEX HEAD FULL THREAD ZINC	F81003-2	2	

# 2

## Side Fence (CE Version Only)

### Side Fence Barriers

### 2.6 Side Fence Barriers

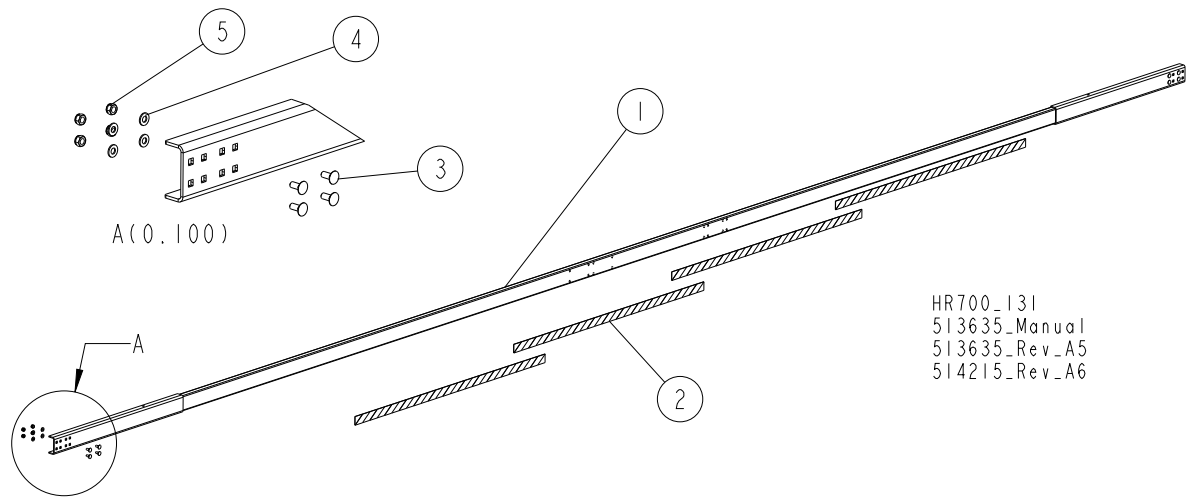

REF.	DESCRIPTION (◆ Indicates Parts Available In Assemblies Only)	PART#	QTY
	<b>BARRIER, HR700-1/HR700-2 SIDE FENCE - COMPLETE</b>	<b>514367</b>	<b>1/0/0</b>
	<b>BARRIER, HR700-3/HR700-4 SIDE FENCE - COMPLETE</b>	<b>514366</b>	<b>0/1/0</b>
	<b>BARRIER, HR700-5/HR700-6 SIDE FENCE - COMPLETE</b>	<b>514215</b>	<b>0/0/1</b>
1	BARRIER, HR700-1/HR700-2 SIDE FENCE	514359-1	1/0/0
	BARRIER, HR700-3/HR700-4 SIDE FENCE	514218-1	0/1/0
	BARRIER, HR700-5/HR700-6 SIDE FENCE	514216-1	0/0/1
2	DECAL, SAFETY WARNING (BLACK&YELLOW)	099368	1/2/4
3	BOLT, M8X20-8.8 CARRIAGE HEAD ZINC	F81002-11	8
4	WASHER, 8.4 FLAT ZINC	F81054-1	8
5	NUT, M8-8-B HEX NYLON ZINC LOCK	F81032-2	8