

Horizontal Resaw

HR700

Parts List

HR700E20S	rev. A1.00
(HR1-6E20S)	rev. A1.00
HR700E25	rev. A1.00
(HR1-6E25)	rev. A1.00



Safety is our #1 concern! Read and understand all safety information and instructions before operating, setting up or maintaining this machine.

June 2014

Form #1023

Table of Contents

Section-Page

SECTION 1 REPLACEMENT PARTS		1-1
1.1	How To Use The Parts List	1-1
1.1	Sample Assembly	1-1
1.2	Main Module Base	1-2
1.3	Main Module Feed Track, HR700	1-4
1.4	Additional Module Base, HR700	1-6
1.5	Additional Module Feed Track, HR700	1-7
1.6	Feed Chain Drive Assembly, HR700	1-9
1.7	HR700 Hold-Down Rollers.....	1-11
1.8	Air Supply Assembly	1-12
1.9	Drive Roller, HR700	1-13
1.10	Up/Down System, HR700	1-16
1.11	Blade Guide Assembly, Idle Side	1-18
1.12	Blade Guide Assembly, Drive Side	1-19
1.13	Blade Wheel Assembly, Drive Side	1-20
1.14	Blade Wheel Assembly, Idle Side.....	1-21
1.15	Water Bottle Assembly (Option)	1-22
1.16	Blade Lube System.....	1-23
1.17	HR700 Saw Head Warning Decals	1-25
1.18	Pneumatic System Decals	1-27
1.19	HR700 Saw Head	1-28
1.20	Front Blade Housing Cover	1-29
1.21	Adjustable Saw Head Guide Rollers	1-31
1.22	Fixed Saw Head Guide Rollers	1-32
1.23	HR700 Vertical Mast	1-33
1.24	Drive Belt Guard	1-35
1.25	Blade Guide Arm	1-36
1.26	E20 (Standard) & E25 (Option) Motors	1-38
1.27	E15 Motor Assembly (Option)	1-39
1.28	Feed Chain Drive & Tensioner.....	1-40
1.29	Idle Roller Table, SLPIRT	1-42
1.30	Cross Roller Table, SLPCRT	1-44
1.31	Hydraulic Blade Tensioner Assembly	1-46
1.32	Hydraulic Blade Tensioner	1-48
1.33	Hydraulic Pump Assembly	1-50
1.34	Control Box	1-52
1.35	Up/Down Screw Drive Assembly, HR700 (Option)	1-54
1.36	Ground Cable	1-58

SECTION 1 REPLACEMENT PARTS

1.1 How To Use The Parts List

- Go to the appropriate section and locate the part in the illustration.
- Use the number pointing to the part to locate the correct part number and description in the table.
- Parts shown indented under another part are included with that part.
- Parts marked with a diamond (◆) are only available in the assembly listed above the part.

See the sample table below. Sample Part #A01111 includes part F02222-2 and subassembly A03333. Subassembly A03333 includes part S04444-4 and subassembly K05555. The diamond (◆) indicates that S04444-4 is not available except in subassembly A03333. Subassembly K05555 includes parts M06666 and F07777-77. The diamond (◆) indicates M06666 is not available except in subassembly K05555.

1.1 Sample Assembly				
REF.	DESCRIPTION (◆ Indicates Parts Available In Assemblies Only)	PART #	QTY.	
	SAMPLE ASSEMBLY, COMPLETE (INCLUDES ALL INDENTED PARTS BELOW)	A01111	1	
1	Sample Part	F02222-22	1	
2	Sample Subassembly (Includes All Indented Parts Below)	A03333	1	
	Sample Part (◆ Indicates Part Is Only Available With A03333)	S04444-4	1	◆
3	Sample Subassembly (Includes All Indented Parts Below)	K05555	1	
	Sample Part (◆ Indicates Part Is Only Available With K05555)	M06666	2	◆
4	Sample Part	F07777-77	1	

To Order Parts:

From Europe call your local distributor or our European Headquarters and Manufacturing Facility in Kolo, Nagórna 114 St, Poland at **+48-63-2626000** or **+48-3912-1319**. From the continental U.S., call at **1-800-448-7881**. Have your customer number, vehicle identification number, and part numbers ready when you call. From other international locations, contact the Wood-Mizer distributor in your area for parts.



CAUTION! It is strongly recommended that only original spare parts be used.

1 REPLACEMENT PARTS

Main Module Base

1.2 Main Module Base

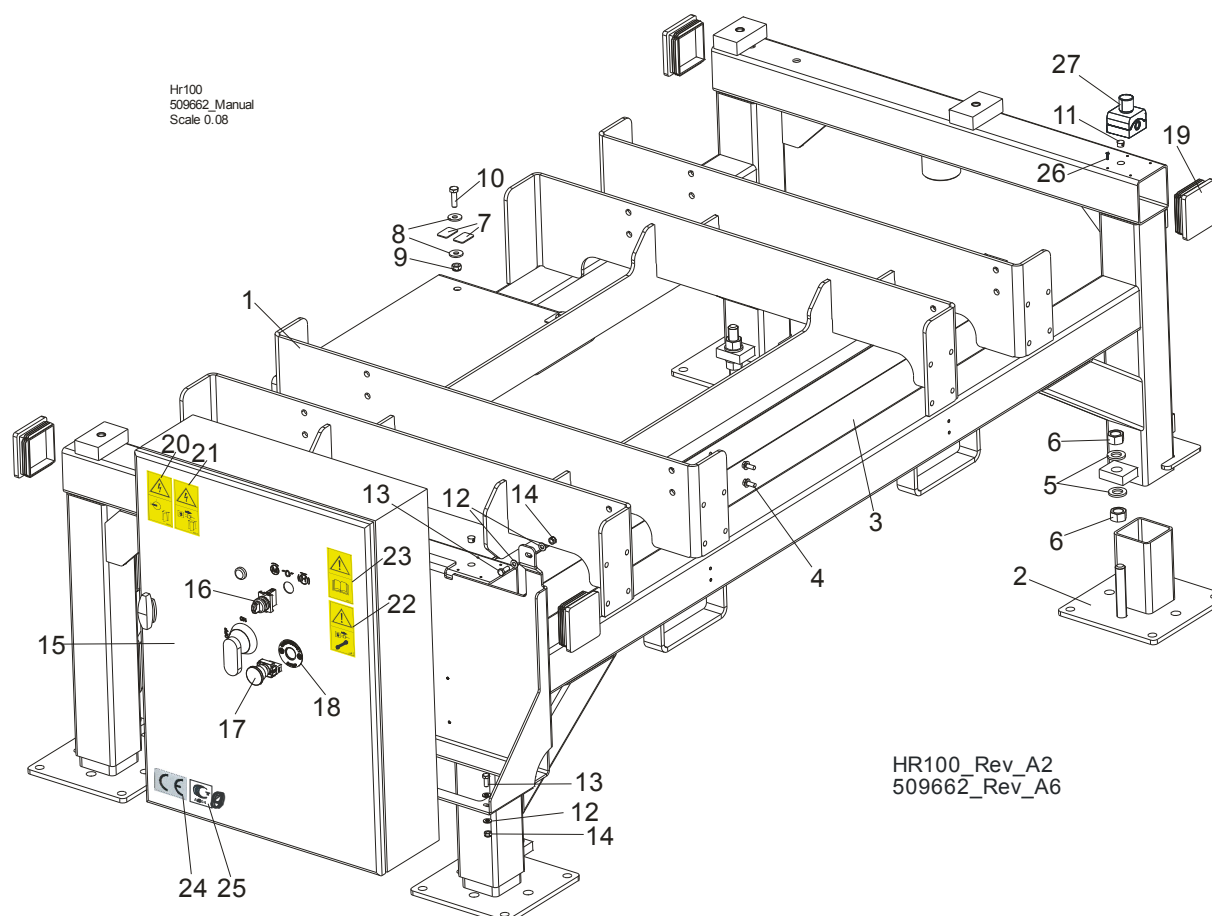

REF.	DESCRIPTION (◆ Indicates Parts Available In Assemblies Only)	PART #	QTY.
	BASE, HR700-2 MAIN MODULE - COMPLETE	509679	1
1	FRAME, HR700-2 MAIN MODULE BASE	509680-1	1
2	FOOT, LEG ADJUSTABLE	099547-1	4
3	DUCT, HR700-2 CABLE	511811	1
4	SCREW, 5/16-18 X 3/4 SELF-TAPPING	F05015-30	6
5	WASHER, 21 FLAT ZINC	F81059-2	8
6	NUT, M20-8 HEX ZINC	F81037-1	8
7	WASHER, SELF-ADHESIVE CORK	502881	8
8	WASHER, 10.5 SPECIAL FLAT ZINC	F81055-6	8
9	NUT, M10-8-B HEX NYLON ZINC LOCK	F81033-1	4
10	BOLT, M10X35 8.8 HEX HEAD FULL THREAD ZINC	F81003-17	4
11	PLUG, 12.7 HOLE HEYMAN DP-812	086773	2
12	WASHER, 8.4 FLAT ZINC	F81054-1	12
13	BOLT, M8X20 8.8 HEX HEAD FULL THREAD ZINC	F81002-4	6
14	NUT, M8-8-B HEX NYLON ZINC LOCK	F81032-2	6
15	BOX, HR700 E15/E25 ELECTRIC	512136-M1	1
16	SWITCH, MOELLER 3-POSITION GREEN	091359	1
17	BUTTON, EMERGENCY STOP	086556	1
18	WASHER, EMERGENCY STOP BUTTON	086561	1

REPLACEMENT PARTS

Main Module Base

1

REF.	DESCRIPTION (◆ Indicates Parts Available In Assemblies Only)	PART #	QTY.	
19	CAP, 100X100 #199200 SQUARE	090694	4	
20	DECAL, HAZARDOUS VOLTAGE INSIDE THE ELECTRIC BOX (PICTOGRAM)	096316	1	
21	DECAL, REMOVE THE PLUG BEFORE OPENING THE ELECTRIC BOX (PICTOGRAM)	096319	1	
22	DECAL, DISCONNECT POWER SUPPLY BEFORE SERVICING (PICTOGRAM)	098177	1	
23	DECAL, READ THE OPERATOR'S MANUAL (PICTOGRAM)	096317	1	
24	DECAL, CE CERTIFIED MACHINE (SMALL)	P85070	1	
25	DECAL, RUSSIAN SAFETY CERTIFICATION	099401	1	
26	SCREW, M4X16 5.8-B CROSS RECESSED PAN HEAD ZINC	F81011-42	4	
27	BUTTON, M22-PV/KC02/IY EMERGENCY STOP	094726	1	

1 REPLACEMENT PARTS

Main Module Feed Track, HR700

1.3 Main Module Feed Track, HR700

Hr102
509662_Manual
Scale 0.055

HR102_Rev_A2
509662_Rev_A6

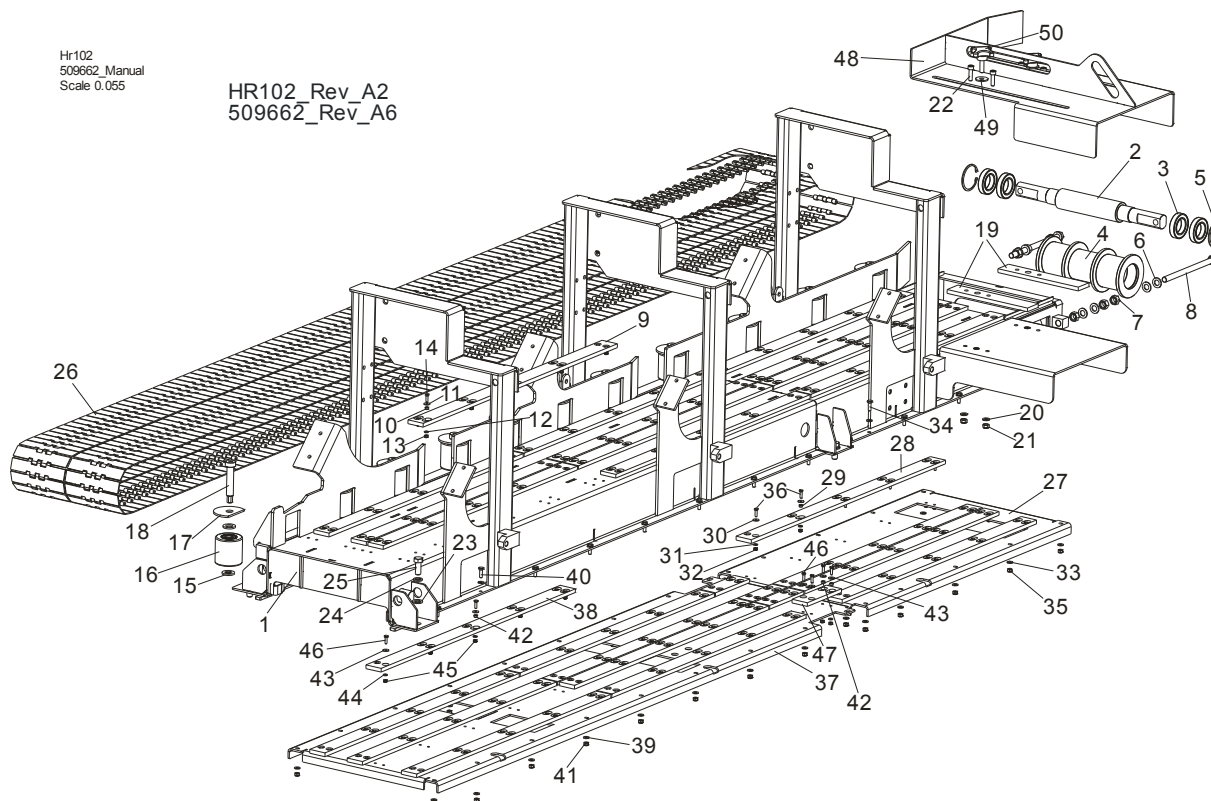

REF.	DESCRIPTION (◆ Indicates Parts Available In Assemblies Only)	PART #	QTY.
	TRACK, HR700 MAIN MODULE FEED - COMPLETE	509595	1
1	TRACK, HR700-2 MAIN MODULE FEED	509596-1	1
	TENSIONER, HR700 CHAIN - COMPLETE	509637	1
2	SHAFT, TENSION PULLEY ZINC-PLATED	509639-1	1
3	BEARING, 6009.2RSR (FAG) ROLLING	096025	4
4	PULLEY, CHAIN TENSION ZINC-PLATED	509638-1	1
5	RING, W75 INSIDE RETAINING	F81090-41	2
6	WASHER, 17 SPLIT LOCK ZINC	F81058-1	8
7	NUT, M16-8 HEX ZINC	F81036-1	6
8	BOLT, ISO 4017-M16X240-8.8-A2E. HEX HEAD FULL THREAD	F81006-29	2
9	PAD, FEED TRACK PLASTIC	092080	12
10	BUSHING, 6.2X10X5 ZINC-PLATED SPACER	503674-1	96
11	WASHER, 6.5 SPECIAL FLAT ZINC	F81053-11	120
12	WASHER, 6.4 FLAT ZINC	F81053-1	120
13	NUT, M6-8-B HEX NYLON ZINC LOCK	F81031-2	120
14	BOLT, M6X20 8.8 HEX HEAD FULL THREAD ZINC	F81001-2	118
15	WASHER, 21 FLAT ZINC	F81059-2	22
16	ROLLER, 80 R80-80-80 (ZABI) PLASTIC	099429	11
17	PLATE, GUIDE ROLLER COVER ZINC-PLATED	099441-1	11
18	BOLT, 20/M16X90 12.9 ISO7379 (BOSSARD) SHOULDER	F81006-30	11

REPLACEMENT PARTS

Main Module Feed Track, HR700

1

REF.	DESCRIPTION (◆ Indicates Parts Available In Assemblies Only)	PART #	QTY.	
19	WASHER, LOG GUIDE SLIDE	099478	2	
20	WASHER, 10.5 FLAT ZINC	F81055-1	4	
21	NUT, M10-8-B HEX NYLON ZINC LOCK	F81033-1	4	
22	SCREW, M10X35-8.8 HEX SOCKET HEAD CAP ZINC	F81003-56	4	
23	WASHER, 17 FLAT ZINC	F81058-1	4	
24	WASHER, 16.3 SPLIT LOCK ZINC	F81058-2	4	
25	BOLT, M16X40-8.8 HEX HEAD FULL THREAD ZINC	F81006-13	4	
26	CHAIN, ACCATE S802 K750 7.94.110 (204-LINK)	099080	2	
	PLATE, SHORT CHAIN SUPPORT - COMPLETE	509624	1	
27	PLATE, SHORT CHAIN SUPPORT	509626-1	1	
28	PAD, FEED TRACK PLASTIC	092080	4	
29	BUSHING, 6.2X10X5 ZINC-PLATED SPACER	503674-1	32	
30	WASHER, 6.5 SPECIAL FLAT ZINC	F81053-11	40	
31	WASHER, 6.4 FLAT ZINC	F81053-1	40	
32	NUT, M6-8-B HEX NYLON ZINC LOCK	F81031-2	40	
33	WASHER, 8.4 FLAT ZINC	F81054-1	20	
34	BOLT, M8X25-8.8-B HEX HEAD FULL THREAD ZINC	F81002-5	10	
35	NUT, M8 8 HEX NYLON ZINC LOCK	F81032-2	10	
36	BOLT, M6X20 8.8 HEX HEAD FULL THREAD ZINC	F81001-2	42	
	PLATE, LONG CHAIN SUPPORT - COMPLETE	509620	1	
37	PLATE, LONG CHAIN SUPPORT	509622-1	1	
38	PAD, FEED TRACK PLASTIC	092080	8	
39	WASHER, 8.4 FLAT ZINC	F81054-1	36	
40	BOLT, M8X25-8.8-B HEX HEAD FULL THREAD ZINC	F81002-5	18	
41	NUT, M8 8 HEX NYLON ZINC LOCK	F81032-2	18	
42	BUSHING, 6.2X10X5 ZINC-PLATED SPACER	503674-1	72	
43	WASHER, 6.5 SPECIAL FLAT ZINC	F81053-11	96	
44	WASHER, 6.4 FLAT ZINC	F81053-1	96	
45	NUT, M6-8-B HEX NYLON ZINC LOCK	F81031-2	96	
46	BOLT, M6X20 8.8 HEX HEAD FULL THREAD ZINC	F81001-2	96	
47	PAD, FEED TRACK PLASTIC - SHORT	099430	4	
48	BRACKET, HR700 LOG GUIDE	511819-1	1	
49	WASHER, 13 SPECIAL FLAT ZINC	F81056-14	2	
50	KNOB, SR1580 80X40M12 (466408 MOSS)	100848	2	

1 REPLACEMENT PARTS

Additional Module Base, HR700

1.4 Additional Module Base, HR700

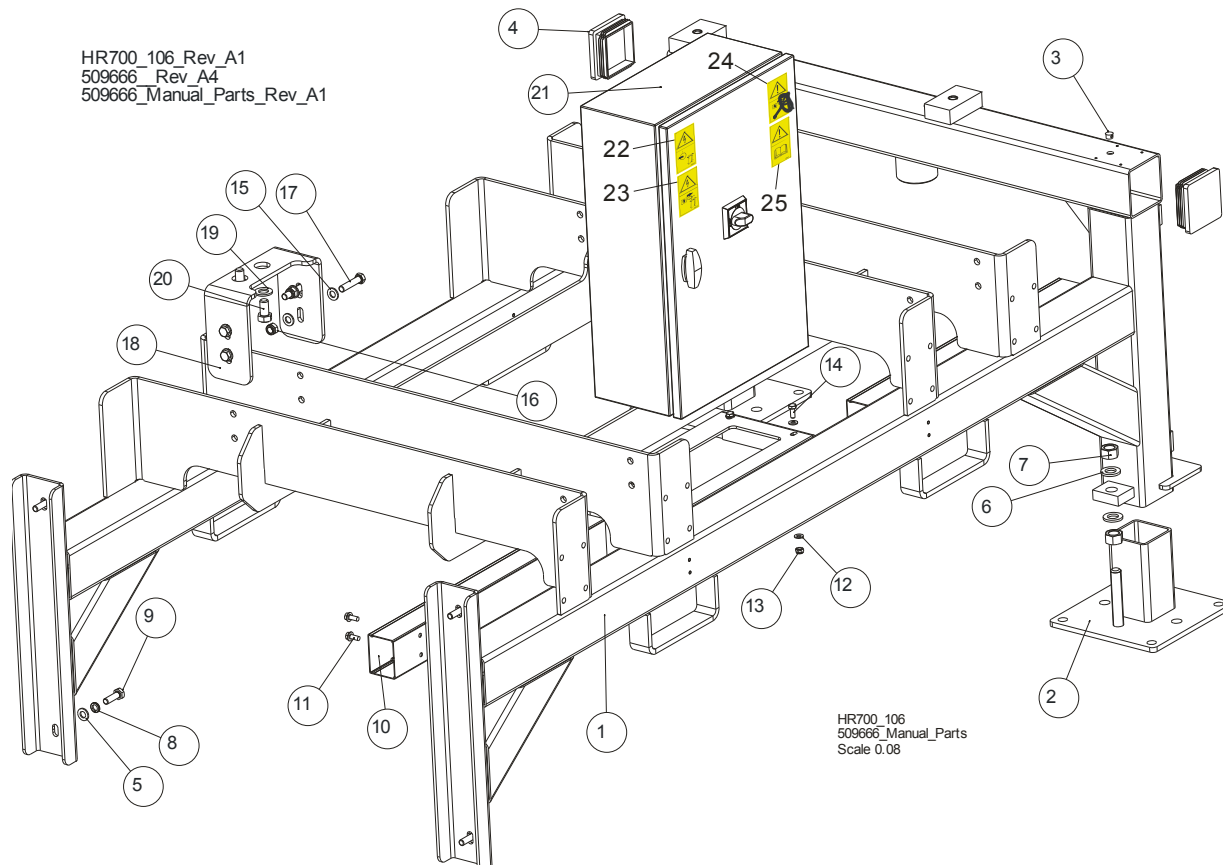

REF.	DESCRIPTION (◆ Indicates Parts Available In Assemblies Only)	PART #	QTY.
	MODULE, HR700-2 ADDITIONAL - COMPLETE	509643	1
	BASE, HR700-2 ADDITIONAL MODULE - COMPLETE	509681	1
1	BASE, HR700-2 ADDITIONAL MODULE	509682-1	1
2	FOOT, ADJUSTABLE LEG	099547-1	2
3	PLUG, 12.7 HOLE HEYMAN DP-812	086773	1
4	CAP, 100X100 #199200 SQUARE	090694	2
5	WASHER, 13 FLAT ZINC	F81056-1	4
6	WASHER, 21 FLAT ZINC	F81059-2	4
7	NUT, M20-8 HEX ZINC	F81037-1	4
8	WASHER, Z12.2 SPLIT LOCK ZINC	F81056-2	4
9	BOLT, M12X40-8.8 HEX HEAD FULL THREAD ZINC	F81004-4	4
10	DUCT, HR700-2 CABLE	511812	2
11	SCREW, 5/16-18 X 3/4 SELF-TAPPING	F05015-30	8
12	WASHER, 8.4 FLAT ZINC	F81054-1	8
13	NUT, M8 8 HEX NYLON ZINC LOCK	F81032-2	4
14	BOLT, M8X20 8.8 HEX HEAD FULL THREAD ZINC	F81002-4	4
15	WASHER, 13 FLAT ZINC	F81056-1	8
16	NUT, M12-8 HEX NYLON ZINC LOCK	F81034-2	4
17	BOLT, M12x55-8.8 HEX HEAD ZINC	F81004-12	4
18	BRACKET, HR700 FEED TRACK SUPPORT	513495	1

REPLACEMENT PARTS

Additional Module Feed Track, HR700

1

REF.	DESCRIPTION (◆ Indicates Parts Available In Assemblies Only)	PART #	QTY.
19	WASHER, 19 FLAT ZINC	F81060-1	2
20	BOLT, M16x30-8.8 HEX HEAD FULL THREAD ZINC	F81006-36	2
21	BOX, HR ELECTRIC - ADDITIONAL MODULE	507270-M2 ¹	1
	BOX, HR ELECTRIC - ADDITIONAL MODULE	507270-M3 ²	1
22	DECAL, HAZARDOUS VOLTAGE INSIDE THE ELECTRIC BOX (PICTOGRAM)	096316	1
23	DECAL, REMOVE THE PLUG BEFORE OPENING THE ELECTRIC BOX (PICTOGRAM)	096319	1
24	DECAL, DISCONNECT POWER SUPPLY BEFORE SERVICING (PICTOGRAM)	098177	1
25	DECAL, READ THE OPERATOR'S MANUAL (PICTOGRAM)	096317	1

¹ Used on: 509663, 509664, 509665, 509666 (one piece on each).

² Used together with 507270-M2 on: 099665, 509666 (one piece on each).

1.5 Additional Module Feed Track, HR700

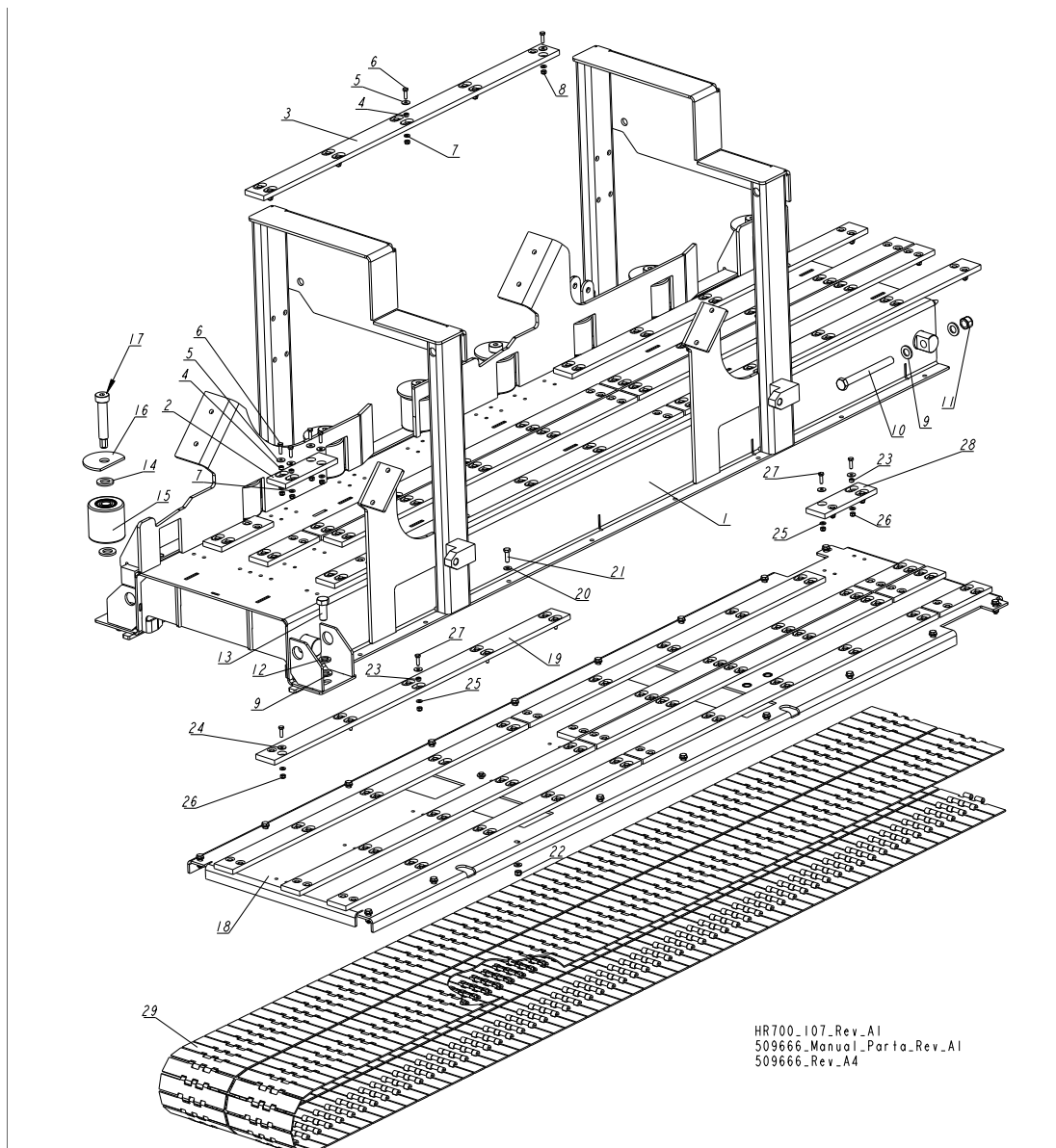

1

REPLACEMENT PARTS

Additional Module Feed Track, HR700

REF.	DESCRIPTION (◆ Indicates Parts Available In Assemblies Only)	PART #	QTY.	
	TRACK, HR700 ADDITIONAL MODULE FEED - COMPLETE	509644	1	
1	TRACK, HR700-2 ADDITIONAL MODULE FEED	509645-1	1	
2	PAD, FEED TRACK PLASTIC - SHORT	099430	4	
3	PAD, FEED TRACK PLASTIC	092080	8	
4	BUSHING, 6.2X10X5 ZINC-PLATED SPACER	503674-1	72	
5	WASHER, 6.5 SPECIAL FLAT ZINC	F81053-11	96	
6	BOLT, M6X20 8.8 HEX HEAD FULL THREAD ZINC	F81001-2	96	
7	WASHER, 6.4 FLAT ZINC	F81053-1	96	
8	NUT, M6-8-B HEX NYLON ZINC LOCK	F81031-2	96	
9	WASHER, 17 SPLIT LOCK ZINC	F81058-1	6	
10	BOLT, M16X160 HEX HEAD ZINC	F81006-20	2	
11	NUT, M16-8 HEX NYLON ZINC LOCK	F81036-2	2	
12	WASHER, 16.3 SPLIT LOCK ZINC	F81058-2	2	
13	BOLT, M16X40-8.8 HEX HEAD FULL THREAD ZINC	F81006-13	2	
14	WASHER, 21 FLAT ZINC	F81059-2	16	
15	ROLLER, 80 R80-80-80 (ZABI) PLASTIC	099429	8	
16	PLATE, GUIDE ROLLER COVER ZINC-PLATED	099441-1	8	
17	BOLT, 20/M16X90 12.9 ISO7379 (BOSSARD) SHOULDER	F81006-30	8	
	PLATE, LONG CHAIN SUPPORT - COMPLETE	511875	1	
18	PLATE, LONG CHAIN SUPPORT	511876	1	
19	PAD, FEED TRACK PLASTIC	092080	8	
20	WASHER, 8.4 FLAT ZINC	F81054-1	36	
21	BOLT, M8X25-8.8-B HEX HEAD FULL THREAD ZINC	F81002-5	18	
22	NUT, M8 8 HEX NYLON ZINC LOCK	F81032-2	18	
23	BUSHING, 6.2X10X5 ZINC-PLATED SPACER	503674-1	72	
24	WASHER, 6.5 SPECIAL FLAT ZINC	F81053-11	96	
25	WASHER, 6.4 FLAT ZINC	F81053-1	96	
26	NUT, M6-8-B HEX NYLON ZINC LOCK	F81031-2	96	
27	BOLT, M6X20 8.8 HEX HEAD FULL THREAD ZINC	F81001-2	96	
28	PAD, FEED TRACK PLASTIC - SHORT	099430	4	
29	CHAIN, ACCATE S802 K750 7.94.110 (116-LINK)	099344	2	

1.6 Feed Chain Drive Assembly, HR700

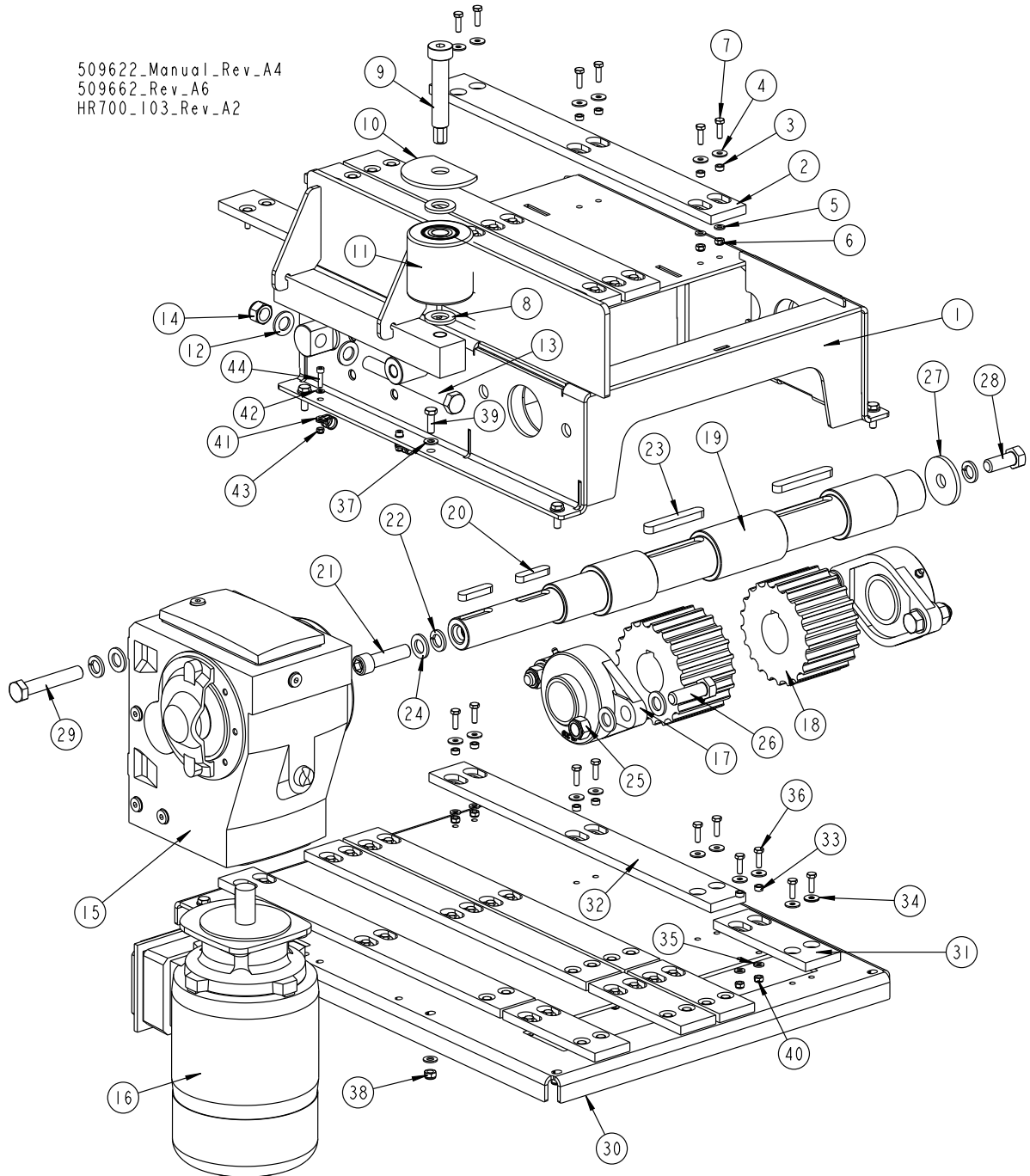

REF.	DESCRIPTION (◆ Indicates Parts Available In Assemblies Only)	PART #	QTY.
	DRIVE ASSEMBLY, HR700 FEED CHAIN	509611	1
1	BRACKET, CHAIN DRIVE MOUNT	509612-1	1
2	PAD, FEED TRACK PLASTIC (MEDIUM)	099376	4



REPLACEMENT PARTS

Feed Chain Drive Assembly, HR700

REF.	DESCRIPTION (◆ Indicates Parts Available In Assemblies Only)	PART #	QTY.
3	BUSHING, 6.2X10X5 ZINC-PLATED SPACER	503674-1	16
4	WASHER, 6.5 SPECIAL FLAT ZINC	F81053-11	24
5	WASHER, 6.4 FLAT ZINC	F81053-1	16
6	NUT, M6-8-B HEX NYLON ZINC LOCK	F81031-2	16
7	BOLT, M6X20 8.8 HEX HEAD FULL THREAD ZINC	F81001-2	24
8	WASHER, 21 FLAT ZINC	F81059-2	2
9	BOLT, 20/M16X90 12.9 ISO7379 (BOSSARD) SHOULDER	F81006-30	1
10	PLATE, GUIDE ROLLER COVER ZINC-PLATED	099441-1	1
11	ROLLER, 80 R80-80-80 (ZABI) PLASTIC	099429	1
12	WASHER, 17 SPLIT LOCK ZINC	F81058-1	4
13	BOLT, M16X160 HEX HEAD ZINC	F81006-20	2
14	NUT, M16-8 HEX NYLON ZINC LOCK	F81036-2	2
	DRIVE ASSEMBLY, FEED CHAIN	509634	1
	MOTOREDUCTER, SK9022.1AZDBH-90LH/4TF,I=49.01,M2,F3.0	509630	1
15	REDUCER, SK9022.1AZBDH I=49.01 (NORD)	511846	1
16	MOTOR, SK 90LH/4 TF 1.5KW1400 (NORD)	511845	1
17	BEARING, UCFL210 W/HOUSING	098824	2
18	SPROCKET, KZN 800/21 A=80 B=50	099079	2
19	SHAFT, HR700 ZINC-PLATED DRIVE	509635-1	1
20	KEY, A12X8X50 DIN6885 PARALLEL	506735	2
21	SCREW, M16X60-8.8 HEX SOCKET HEAD CAP ZINC	F81006-19	1
22	WASHER, 16.3 SPLIT LOCK ZINC	F81058-2	3
23	KEY, A14X9X90 PARALLEL	099424	2
24	WASHER, 17 SPLIT LOCK ZINC	F81058-1	10
25	NUT, M16-8 HEX NYLON ZINC LOCK	F81036-2	4
26	BOLT, M16X50-8.8 HEX HEAD FULL THREAD ZINC	F81006-7	4
27	WASHER, 60X17X6 ZINC-PLATED CLAMPING	509636-1	1
28	BOLT, M16X40-8.8 HEX HEAD FULL THREAD ZINC	F81006-13	1
29	BOLT, M16X90-8.8 HEX HEAD ZINC	F81006-17	1
	PLATE, FEED CHAIN SUPPORT - COMPLETE	509631	1
30	PLATE, FEED CHAIN SUPPORT	511822-1	1
31	PAD, FEED TRACK PLASTIC (SHORT)	099430	4
32	PAD, FEED TRACK PLASTIC (MEDIUM)	099376	4
33	BUSHING, 6.2X10X5 ZINC-PLATED SPACER	503674-1	24
34	WASHER, 6.5 SPECIAL FLAT ZINC	F81053-11	40
35	WASHER, 6.4 FLAT ZINC	F81053-1	40
36	BOLT, M6X20 8.8 HEX HEAD FULL THREAD ZINC	F81001-2	40
37	WASHER, 8.4 FLAT ZINC	F81054-1	16
38	NUT, M8 8 HEX NYLON ZINC LOCK	F81032-2	8
39	BOLT, M8X25-8.8-B HEX HEAD FULL THREAD ZINC	F81002-5	8
40	NUT, M6-8-B HEX NYLON ZINC LOCK	F81031-2	40
41	CLAMP, RSGU 1.10/12W1 METAL & RUBBER	086861	2
42	WASHER, 5.3 FLAT ZINC	F81052-1	2
43	NUT, M5-8 DIN985 ZINC-PLATED	F81030-2	2
44	SCREW, M5X20 8.8 HEX SOCKET HEAD CAP ZINC	F81000-72	2

1.7 HR700 Hold-Down Rollers

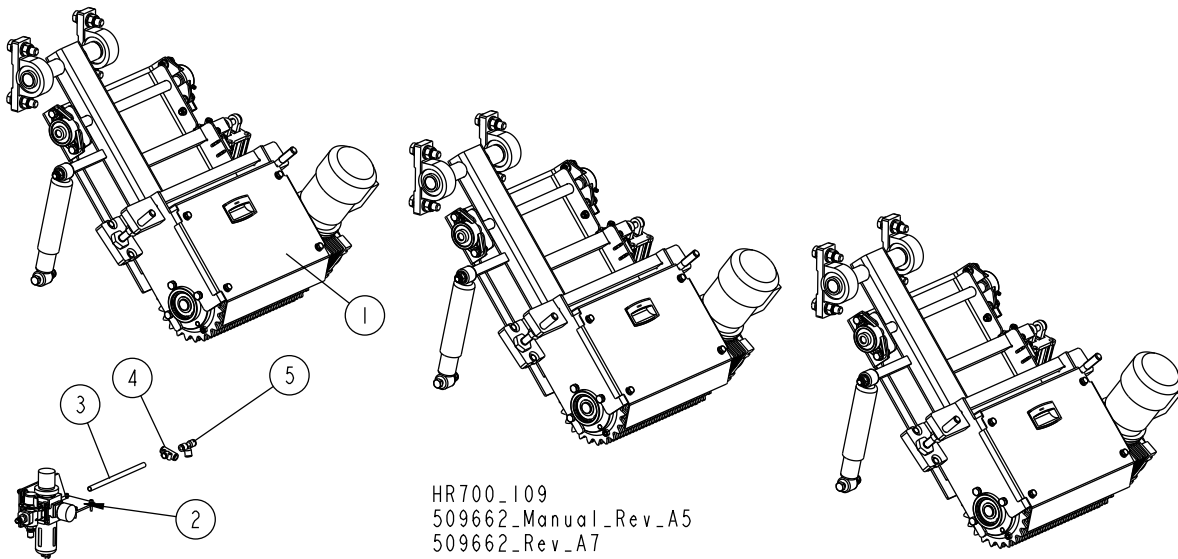

REF.	DESCRIPTION (◆ Indicates Parts Available In Assemblies Only)	PART #	QTY.
	HOLD-DOWN ROLLER KIT, HR700-1	511836	1/0/0/0/0/0
	HOLD-DOWN ROLLER KIT, HR700-2	511837	0/1/0/0/0/0
	HOLD-DOWN ROLLER KIT, HR700-3	511838	0/0/1/0/0/0
	HOLD-DOWN ROLLER KIT, HR700-4	511839	0/0/0/1/0/0
	HOLD-DOWN ROLLER KIT, HR700-5	511840	0/0/0/0/1/0
	HOLD-DOWN ROLLER KIT, HR700-6	511841	0/0/0/0/0/1
1	ROLLER, HR700 DRIVE - COMPLETE See Section 1.9	511895	2/3/4/5/6/7
2	AIR SUPPLY ASSEMBLY See Section 1.8	511847	1
3	HOSE, 10MM POLYURETHANE	096308	1/1/1/0/1/1
4	FITTING, TEE (SMC KQ2T08-10A)	514067	0/1/1/1/1/1
5	FITTING, T KQ2T08-00A TEE	090235	0/1/3/4/5/5
	HOSE, 8MM POLYURETHANE ¹	R80588-6	13.3
	HOSE, 10MM BLUE POLYURETHANE ¹	R80588-8	1.2

¹ Included in 511839

1 REPLACEMENT PARTS

Air Supply Assembly

1.8 Air Supply Assembly

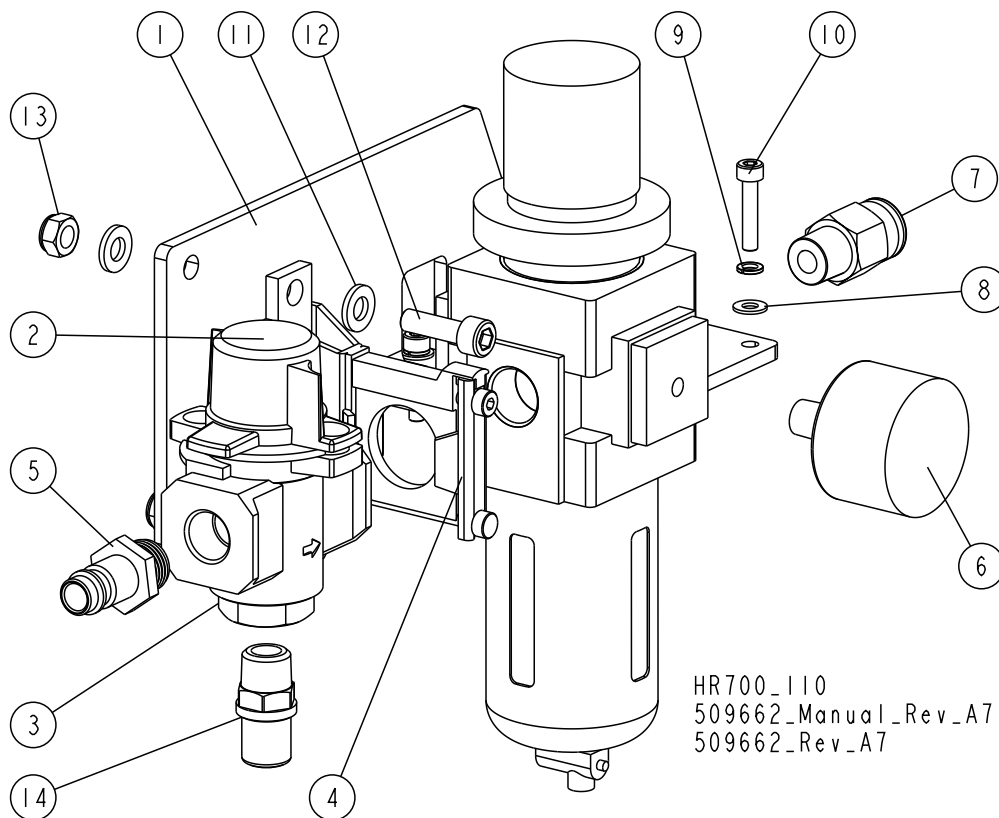

REF.	DESCRIPTION (◆ Indicates Parts Available In Assemblies Only)	PART #	QTY.
	AIR SUPPLY ASSEMBLY	511847	1
1	PLATE, MOUNTING	511848-1	1
2	SPACER, Y300T W/BRACKET	510067	1
3	VALVE, VHS30-F02 SHUT-OFF	510068	1
4	REDUCER, AW30-F03H FILTER	510974	1
5	FITTING, GK 1381A GZ 1/4" MALE	510171	1
6	GAUGE, G36-10-01 (1/8") PRESSURE	510069	1
7	FITTING, (SMC KQ2H10-03) STRAIGHT MALE	510984	1
8	WASHER, 4.3 FLAT ZINC	F81051-2	4
9	WASHER, Z 4.1 SPLIT LOCK ZINC	F81051-1	4
10	SCREW, M4X20 8.8 HEX SOCKET HEAD CAP ZINC	F81011-31	4
11	WASHER, 6.4 FLAT ZINC	F81053-1	4
12	SCREW, M6X20 8.8 HEX SOCKET HEAD CAP ZINC	F81001-22	2
13	NUT, M6-8-B HEX NYLON ZINC LOCK	F81031-2	2
14	SILENCER, AN15-02 (1/4")	510073	1

1.9 Drive Roller, HR700

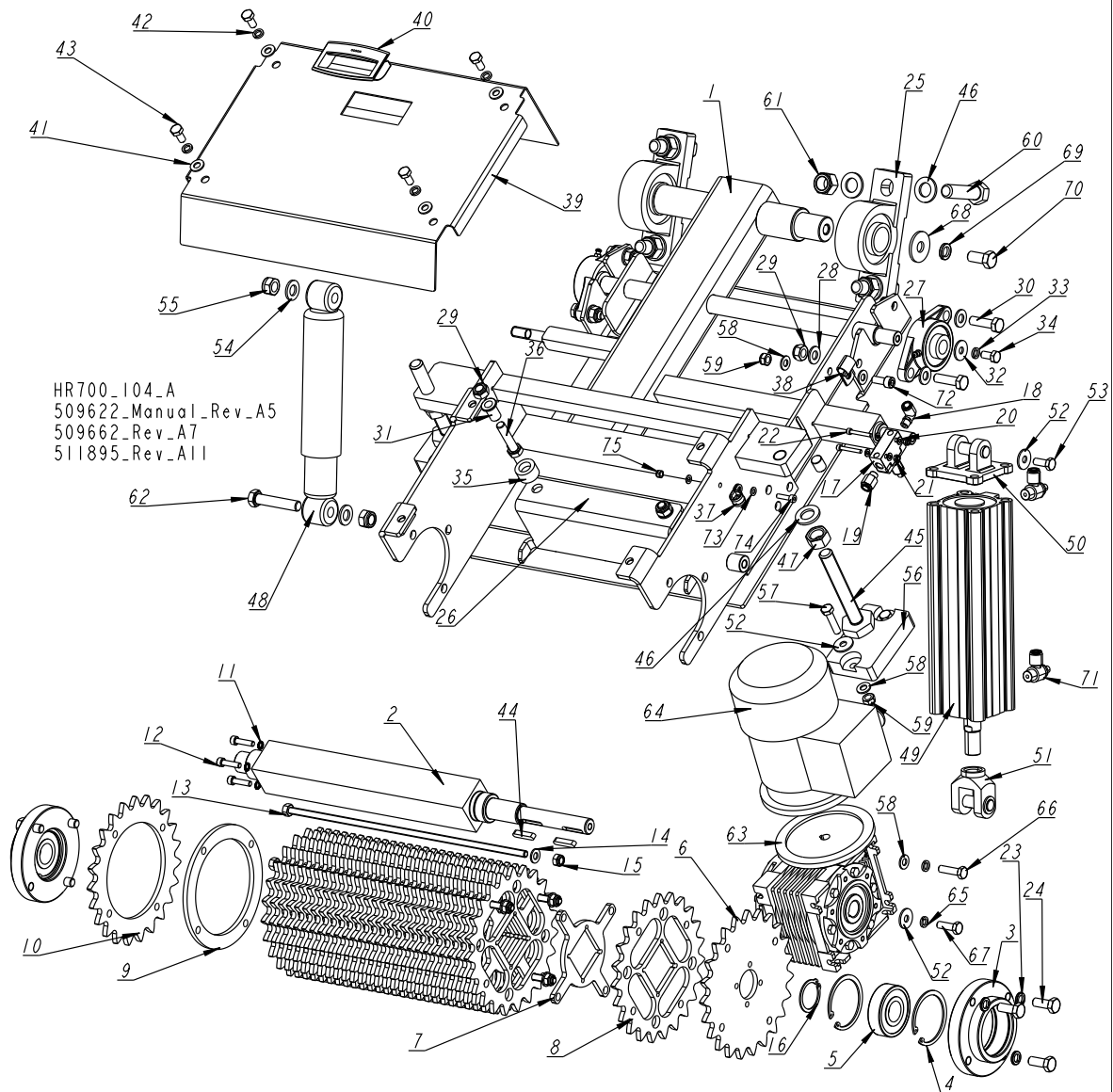

HR700_104_A
 509622_Manual_Rev_A5
 509662_Rev_A7
 511895_Rev_A11

REF.	DESCRIPTION (◆ Indicates Parts Available In Assemblies Only)	PART #	QTY.
	ROLLER, HR700 DRIVE - COMPLETE	511895	1
1	ARM WELDMENT, DRIVE HOLD-DOWN ROLLER	511890-1	1
	SHAFT ASSEMBLY, HR700 DRIVE	511885	1
2	SHAFT, HR700 ROLLER DRIVE	511884	1
	BEARING HOUSING, 6205 - COMPLETE	511883	2
3	HOUSING, 6205 BEARING	512144-1	1
4	RING, 62W INSIDE RETAINING	F81090-1	2

1 REPLACEMENT PARTS

Drive Roller, HR700

REF.	DESCRIPTION (◆ Indicates Parts Available In Assemblies Only)	PART #	QTY.	
5	BEARING, 6305 2RS CX.	085706	1	
6	PLATE, N160 OUTSIDE TOOTHED ZINC-PLATED	511887-1	2	
	TOOTHED PLATE SET	511901	26	
7	PLATE, SPACER	511888-1	1	
8	PLATE, N160 TOOTHED ZINC-PLATED CLAMPING	511886-1	1	
9	RING, OUTSIDE SPACER	511902-1	1	
10	PLATE, N160 DIA. OUTSIDE TOOTHED ZINC-PLATED	511903-1	1	
11	WASHER, Z 6.1 SPLIT LOCK ZINC	F81053-3	4	
12	SCREW, M6X25-8.8 HEX SOCKET HEAD CAP ZINC	F81001-41	4	
13	ROD WELDMENT, ROLLER ZINC-PL. MOUNTING	511905-1	4	
14	WASHER, 8.4 FLAT ZINC	F81054-1	4	
15	NUT, M8 8 HEX NYLON ZINC LOCK	F81032-2	5	
16	RING, Z35 OUTSIDE RETAINING	F81090-36	1	
	MECHANICAL VALVE ASSEMBLY	511854	1	
17	MECHANICAL VALVE, 3/2 G1/8 ROLLER PLUNGER (EVM130-F01-05)	511849	1	
18	FITTING, KQ2L08-01AS (1/8") MALE ELBOW	511851	1	
19	FITTING, KQ2H08-01AS (1/8") STRAIGHT MALE	511850	1	
20	WASHER, 4.3 FLAT ZINC	F81051-2	4	
21	NUT, M4-8 HEX NYLON ZINC LOCK	F81029-1	2	
22	SCREW, M4X30-8.8 DIN 912 HEX SOCKET HEAD CAP ZINC	F81000-85	2	
23	WASHER, Z 10.2 SPLIT LOCK ZINC	F81055-2	6	
24	BOLT, M10X25 8.8 HEX HEAD FULL THREAD	F81003-31	6	
25	HOUSING, UCP206 BEARING	099254	2	
	ACTIVATOR PLATE - COMPLETE	511853	1	
26	PLATE, ZINC-PLATED ACTIVATOR	511900-1	1	
27	BEARING, UCFL 203 (CX) W/HOUSING	507347	2	
28	WASHER, 10.5 FLAT ZINC	F81055-1	8	
29	NUT, M10-8-B HEX NYLON ZINC LOCK	F81033-1	6	
30	BOLT, M10X35 8.8 HEX HEAD FULL THREAD ZINC	F81003-17	4	
31	NUT, M10X13X22 ZINC-PLATED RIVET	F81033-15	2	
32	WASHER, ISO 7093-1-8-200 HV-A2E.	F81054-11	1	
33	WASHER, 8.2 SPLIT LOCK ZINC	F81054-4	1	
34	BOLT, M8X16-8.8-B HEX HEAD FULL THREAD ZINC	F81002-20	1	
35	BOOT, RUBBER BUMPER	089083	2	
36	BOLT, M10X45 HEX HEAD FULL THREAD ZINC	F81003-3	2	
37	CLAMP, RSGU 1.10/12W1 METAL & RUBBER	086861	2	
38	CLAMP, 1/2" EMT COATED	P07584	1	
	GUARD, DRIVE SHAFT - COMPLETE	511858	1	
39	GUARD, DRIVE SHAFT	511859-1	1	
40	HANDLE, EPR.90-PF-C1(261051-C1) SNAP-IN FLUSH PULL	100012	1	
41	WASHER, 8.4 FLAT ZINC	F81054-1	4	
42	WASHER, 8.2 SPLIT LOCK ZINC	F81054-4	4	
43	BOLT, M8X16-8.8-B HEX HEAD FULL THREAD ZINC	F81002-20	4	
44	KEY, A6X6X30 PARALLEL	094245	2	
45	BOLT, M16 ZINC-PLATED	100426-1	2	

REPLACEMENT PARTS*Drive Roller, HR700***1**

REF.	DESCRIPTION (◆ Indicates Parts Available In Assemblies Only)	PART #	QTY.	
46	WASHER, 17 SPLIT LOCK ZINC	F81058-1	10	
47	NUT, M16-8 HEX ZINC	F81036-1	2	
48	ABSORBER, WERTTEILE 554412 SHOCK	513494	1	
	CYLINDER, 63X200 AIR	508875_	1	
49	CYLINDER, CDQ2A63TF-200DCMZ AIR	508882	1	
50	BRACKET, CQ-D063 MOUNTING	508884	1	
51	JOINT, Y-G05 DOUBLE KNUCKLE	508883	1	
52	WASHER, ISO 7093-1-8-200 HV-A2E.	F81054-11	6	
53	BOLT, M8X20 5.8 HEX HEAD FULL THREAD ZINC	F81002-1	1	
54	WASHER, 13 FLAT ZINC	F81056-1	2	
55	NUT, M12-8 FE/ZN5 HEX NYLON ZINC LOCK	F81034-2	2	
56	BUMPER, GRENE 70 3201 0010 RUBBER	094969	2	
57	BOLT, M8X35-8.8 HEX HEAD FULL THREAD ZINC	F81002-13	4	
58	WASHER, 8.4 FLAT ZINC	F81054-1	7	
59	NUT, M8 8 HEX NYLON ZINC LOCK	F81032-2	5	
60	BOLT, M16X60-8.8 HEX HEAD FULL THREAD ZINC	F81006-12	4	
61	NUT, M16-8 HEX NYLON ZINC LOCK	F81036-2	4	
62	BOLT, M12X60-8.8 HEX HEAD FULL THREAD ZINC	F81004-51	1	
	MOTOREDUCER, MR40/51/0.12-1400/PS-N1/RR1/V5.	511889	1	
63	REDUCER, R-40/51/V5 W/TORQUE ARM	511907	1	
64	MOTOR, SKH 63-4A, 0.12 KW, 1400 R.P.M.	511908	1	
65	WASHER, 8.2 SPLIT LOCK ZINC	F81054-4	2	
66	BOLT, M8X30 8.8 HEX HEAD FULL THREAD ZINC	F81002-7	1	
67	BOLT, M8X25-8.8-B HEX HEAD FULL THREAD ZINC	F81002-5	1	
68	WASHER, 13 SPECIAL FLAT ZINC	F81056-14	1	
69	WASHER, Z12.2 SPLIT LOCK ZINC	F81056-2	1	
70	BOLT, M12X25-8.8 HEX HEAD FULL THREAD ZINC	F81004-31	1	
71	VALVE, AS2201F-02-08S AIR FLOW CONTROL	509039	2	
72	SCREW, M8X20-8.8 HEX SOCKET HEAD CAP ZINC	F81002-30	1	
73	WASHER, 5.3 FLAT ZINC	F81052-1	4	
74	SCREW, M5X20 8.8 HEX SOCKET HEAD CAP ZINC	F81000-72	2	
75	NUT, M5-8-FE/ZN5 DIN985	F81030-2	2	

1 REPLACEMENT PARTS

Up/Down System, HR700

1.10 Up/Down System, HR700

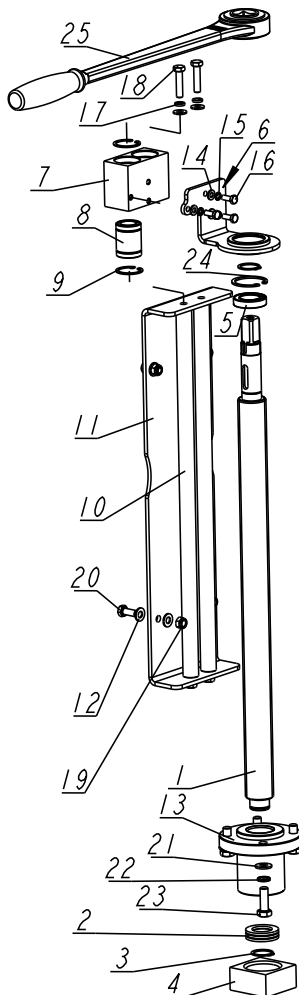

HR700_108_Rev_A1
 509666_Manual_Parts_Rev_A1
 509666_Rev_A4

REF.	DESCRIPTION (◆ Indicates Parts Available In Assemblies Only)	PART #	QTY.
	SAW HEAD HEIGHT ADJUSTMENT KIT - 1-HEAD	511823	1 / 0 / 0 / 0 / 0 / 0
	SAW HEAD HEIGHT ADJUSTMENT KIT - 2-HEAD	511824	0 / 1 / 0 / 0 / 0 / 0
	SAW HEAD HEIGHT ADJUSTMENT KIT - 3-HEAD	511825	0 / 0 / 1 / 0 / 0 / 0
	SAW HEAD HEIGHT ADJUSTMENT KIT - 4-HEAD	511826	0 / 0 / 0 / 1 / 0 / 0
	SAW HEAD HEIGHT ADJUSTMENT KIT - 5-HEAD	511827	0 / 0 / 0 / 0 / 1 / 0
	SAW HEAD HEIGHT ADJUSTMENT KIT - 6-HEAD	511828	0 / 0 / 0 / 0 / 0 / 1
	SAW HEAD HEIGHT ADJUSTMENT ASSEMBLY, SHS/HR700 - MANUAL	506778	1 / 2 / 3 / 4 / 5 / 6

REF.	DESCRIPTION (◆ Indicates Parts Available In Assemblies Only)	PART #	QTY.
	SAW HEAD HEIGHT ADJUSTMENT ASSEMBLY, SHS/HR700 - MANUAL	506778	1

REPLACEMENT PARTS*Up/Down System, HR700***1**

REF.	DESCRIPTION (◆ Indicates Parts Available In Assemblies Only)	PART #	QTY.	
1	SCREW, TR36X3 ACME ZINC-PLATED	506779-1	1	
2	BEARING, 51105 THRUST	088033	1	
3	RING, 25Z OUTSIDE RETAINING	F81090-22	2	
4	BLOCK, ACME SCREW ZINC-PLATED MOUNT	093265-1	1	
5	BEARING, 61905 2RS (COMPLEX)	099037	1	
6	BRACKET, ZINC-PLATED RETAINING	507309-1	1	
	BLOCK, LASER MOUNT - COMPLETE	504010	1	
7	BLOCK, LM 20 UU LINEAR BEARING HOUSING ZINC-PL.	504011-1	1	
8	BEARING, LM 20 UU LINEAR MOTION	504012	2	
9	RING, 32W INSIDE RETAINING	F81090-5	4	
10	ROD, LASER GUIDE (CHROMIUM-PLATED)	504359	2	
11	BRACKET, GUIDE ROD MOUNT	507308-1	1	
12	WASHER, 8.4 FLAT ZINC	F81054-1	12	
13	NUT, TR36X3 ACME SCREW	506780	1	
14	WASHER, 6.4 FLAT ZINC	F81053-1	3	
15	WASHER, Z 6.1 SPLIT LOCK ZINC	F81053-3	3	
16	BOLT, M6X16 8.8 HEX HEAD FULL THREAD ZINC	F81001-32	3	
17	WASHER, 8.2 SPLIT LOCK ZINC	F81054-4	4	
18	BOLT, M8X35-8.8 HEX HEAD FULL THREAD ZINC	F81002-13	4	
19	NUT, M8 8 HEX NYLON ZINC LOCK	F81032-2	4	
20	BOLT, M8X20 8.8 HEX HEAD FULL THREAD ZINC	F81002-4	4	
21	WASHER, 10.5 FLAT ZINC	F81055-1	4	
22	WASHER, Z10.2 SPLIT LOCK ZINC	F81055-2	4	
23	BOLT, M10X30 5.8 HEX HEAD FULL THREAD ZINC	F81003-2	4	
24	RING, SEG W042 RETAINING	F81090-19	1	
25	RATCHET, 3/4" 645300 HEYCO PUSH-THROUGH	507312	1	

1 REPLACEMENT PARTS

Blade Guide Assembly, Idle Side

1.11 Blade Guide Assembly, Idle Side

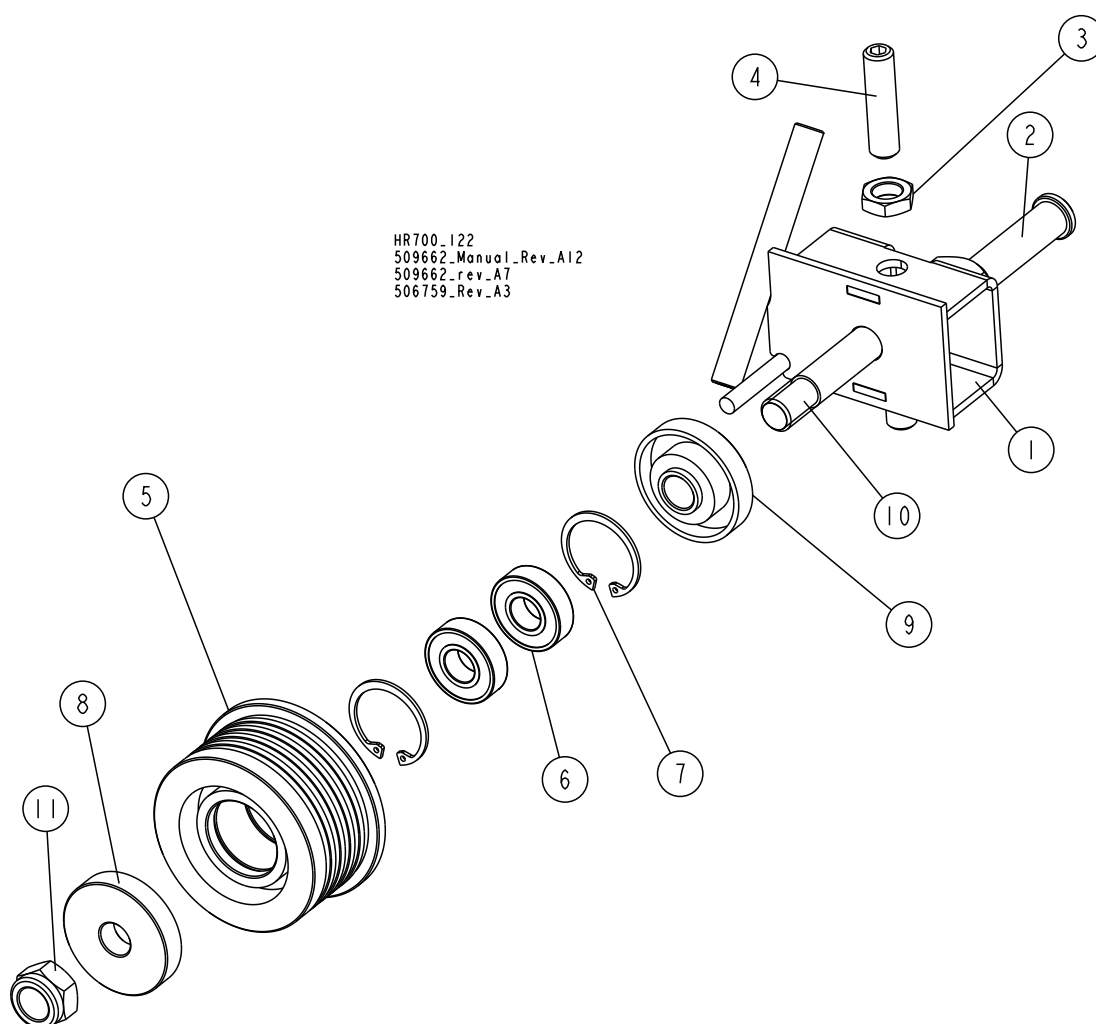

REF.	DESCRIPTION (◆ Indicates Parts Available In Assemblies Only)	PART #	QTY.
	BLADE GUIDE W/EXTENDED ROLLER - IDLE SIDE	506759	1
1	BRACKET WELDMENT, IS BLADE GUIDE ZINC-PLATED	500497-1	1
2	SHAFT, BLADE GUIDE MOUNT ZINC-PLATED	088255-1	1
3	NUT, M10X1-04-ST-A2E ISO8675 THIN	F81033-10	2
4	SCREW, M10X1X40 DIN913 A2-70 STAINLESS STEEL SET	F81015-2	2
	ROLLER ASSEMBLY, BLADE GUIDE W/BEARINGS	500561	1
5	ROLLER, EXTENDED BLADE GUIDE	500560	1
6	BEARING, 6001 2RSR (FAG, SKF)	087893	2
7	RING, W28 WG INSIDE RETAINING	F81090-9	2
8	RING, ZINC-PLATED SPACER	087891-1	1
9	RING, ZINC-PLATED SPACER (EXTENDED BLADE GUIDE ROLLER)	087892-1	1
10	SHAFT, EXTENDED ROLLER ZINC-PLATED	087762-1	1
11	NUT, M12-8 HEX NYLON ZINC LOCK	F81034-2	1

1.12 Blade Guide Assembly, Drive Side

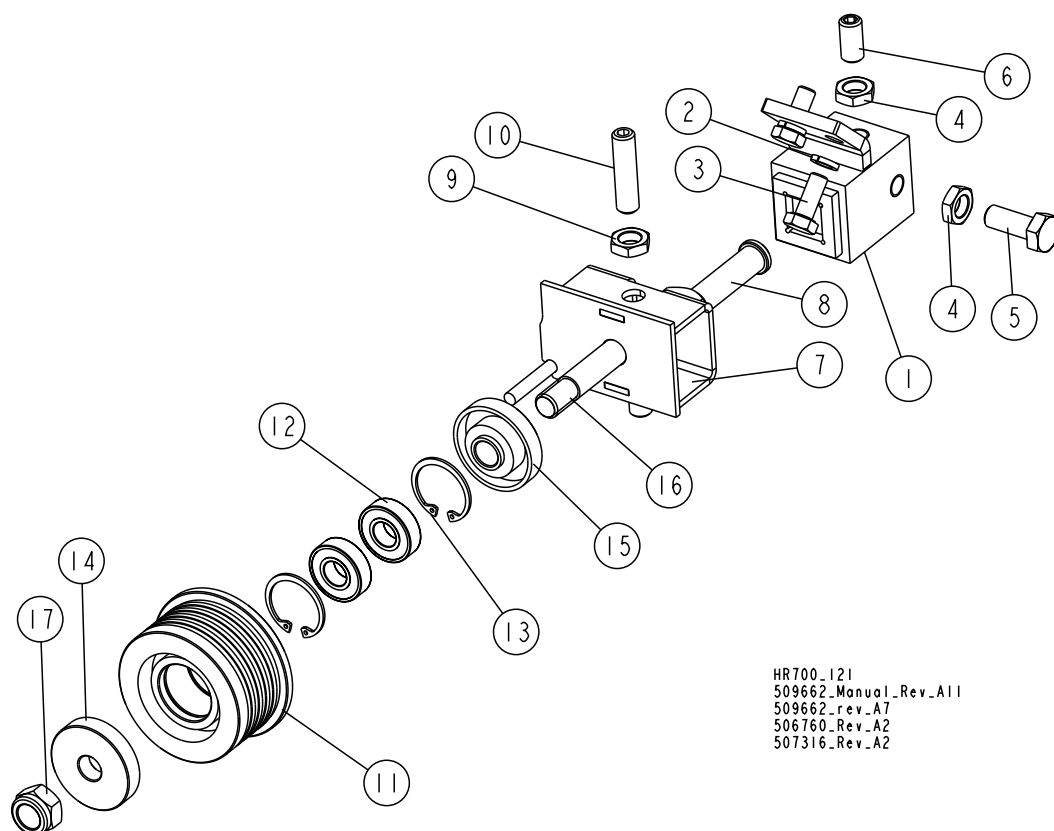

REF.	DESCRIPTION (◆ Indicates Parts Available In Assemblies Only)	PART #	QTY.
	BLOCK, BLADE GUIDE MOUNT - COMPLETE	507316	1
1	BLOCK WELDMENT, BLADE GUIDE MOUNT	088292-1	1
2	WASHER, 8.2 SPLIT LOCK ZINC	F81054-4	2
3	BOLT, M8X20 8.8 HEX HEAD FULL THREAD ZINC	F81002-4	2
4	NUT, M10X1-04-ST-A2E ISO8675 THIN	F81033-10	4
5	BOLT, M10X1X25 DIN 933 STAINLESS STEEL	F81003-28	1
6	SCREW, M10X1X20 DIN 913 STAINLESS STEEL SET	F81015-1	3
	BLADE GUIDE W/EXTENDED ROLLER - DRIVE SIDE	506760	1
7	BRACKET WELDMENT, DRIVE SIDE BLADE GUIDE ROLLER	500498-1	1
8	SHAFT, BLADE GUIDE MOUNT ZINC-PLATED	088255-1	1
9	NUT, M10X1-04-ST-A2E ISO8675 THIN	F81033-10	2
10	SCREW, M10X1X40 DIN913 A2-70 STAINLESS STEEL SET	F81015-2	2
	ROLLER ASSEMBLY, BLADE GUIDE W/BEARINGS	500561	1
11	ROLLER, EXTENDED BLADE GUIDE	500560	1
12	BEARING, 6001 2RSR (FAG, SKF)	087893	2
13	RING, W28 INSIDE RETAINING	F81090-9	2
14	RING, ZINC-PLATED SPACER	087891-1	1
15	RING, ZINC-PLATED SPACER (EXTENDED BLADE GUIDE ROLLER)	087892-1	1
16	SHAFT, EXTENDED ROLLER ZINC-PLATED	087762-1	1
17	NUT, M12-8 HEX NYLON ZINC LOCK	F81034-2	1

REPLACEMENT PARTS

Blade Wheel Assembly, Idle Side

1

21	Nut, M12-8 Hex Nylon Zinc Lock	F81034-2	4	
22	Screw, M8x25 A2-70 DIN 913 Stainless Steel Set	F81014-3	1	
23	Nut, M8-8-B Hex Nylon Zinc Lock	F81032-2	1	
24	Ring, W90 Inside Retaining	F81090-29	2	
25	Washer, 8.4 Flat Zinc	F81054-1	1	
26	PULLEY, SPB Φ224X2/Φ38 (F02312+T31124)	500177	1	
	PULLEY, SPB Φ190X2/Φ38 (F02347+T31124)	500569	1	

1.14 Blade Wheel Assembly, Idle Side

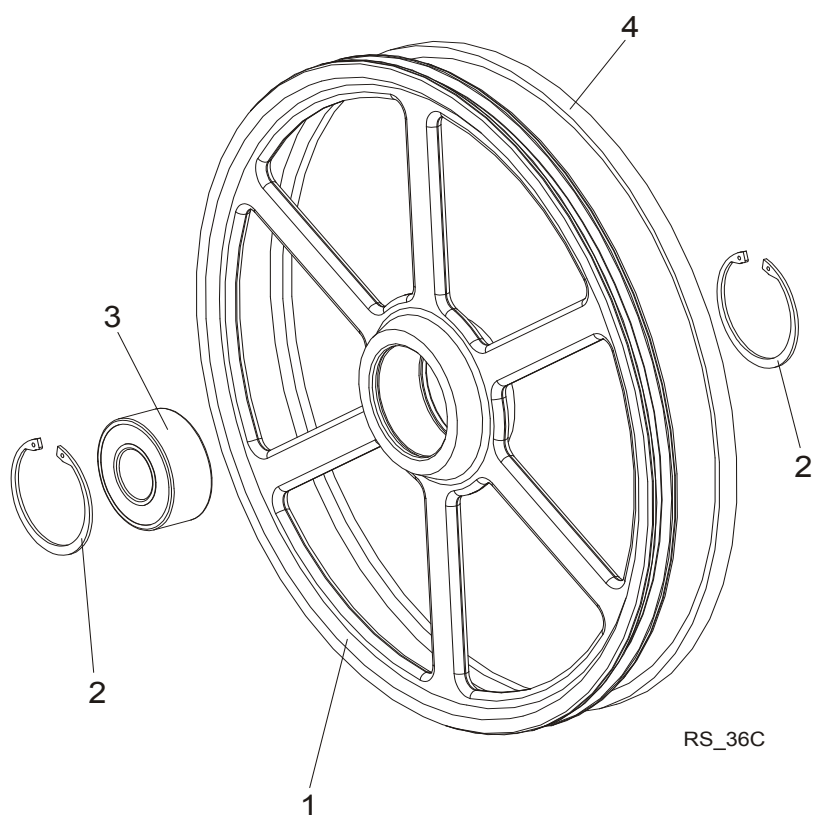

REF.	DESCRIPTION (◆ Indicates Parts Available In Assemblies Only)	PART #	QTY.	
	WHEEL, IDLE SIDE BLADE - COMPLETE	088764	1	
1	Wheel, Idle Side Blade	090810	1	
2	Ring, W100 Inside Retaining	F81090-10	2	
3	Bearing, 3309B.2RSR.TVH FAG	086428	1	
4	V-BELT, B72.5	017922	1	

1 REPLACEMENT PARTS

Water Bottle Assembly (Option)

1.15 Water Bottle Assembly (Option)

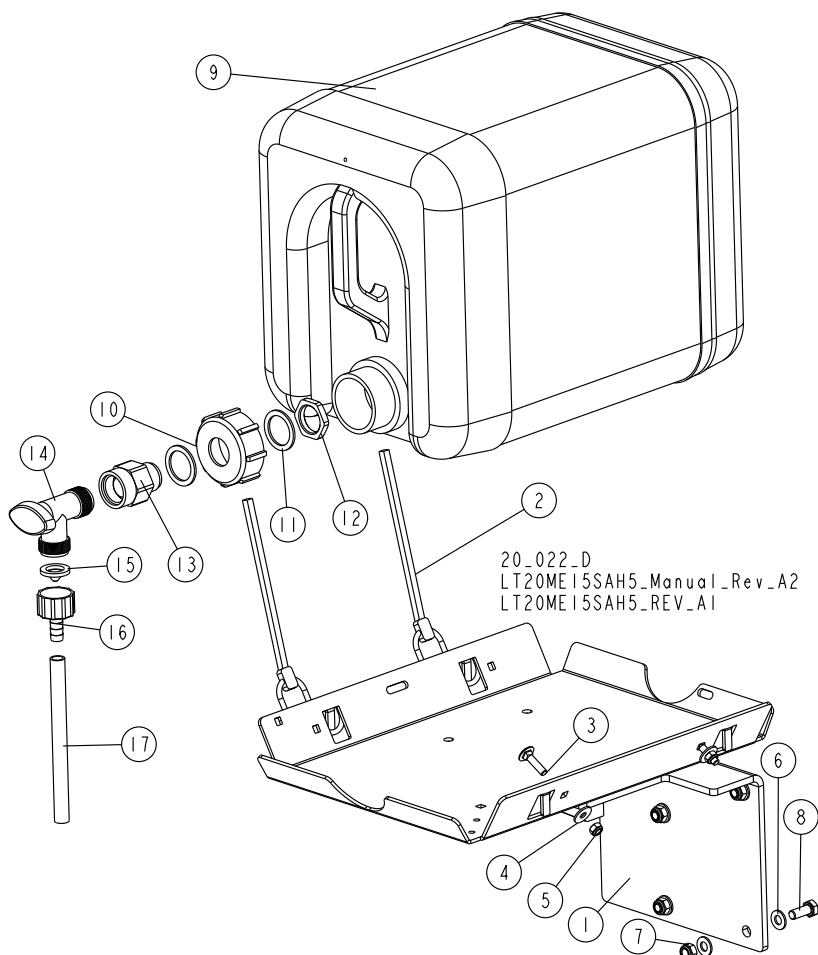

REF.	DESCRIPTION (◆ Indicates Parts Available In Assemblies Only)	PART #	QTY.
	BOTTLE KIT, WATER LUBE	091036	1
1	TRAY WELDMENT, WATER LUBE BOTTLE	091033-1	1
2	STRAP, 20" RUBBER W/HOOK	P11668	2
3	BOLT, M6X25-8.8 CARRIAGE HEAD ZINC	F81001-20	2
4	WASHER, 6.5 SPECIAL FLAT ZINC	F81053-11	2
5	NUT, M6-8-B HEX NYLON ZINC LOCK	F81031-2	2
6	WASHER, 8.4 FLAT ZINC	F81054-1	8
7	NUT, M8-8 HEX NYLON ZINC LOCK	F81032-2	4
8	BOLT, M8X20 8.8 HEX HEAD FULL THREAD ZINC	F81002-4	4
	WATER BOTTLE - COMPLETE	513864	1
	WATER BOTTLE W/CAP	513865	1
9	BOTTLE, WATER	513866	1
10	CAP, WATER BOTTLE	513867	1
11	SEAL, 35X26X2 RUBBER	513869	2
12	NUT, 3/4 NPT GLAND	513868	1

REF.	DESCRIPTION (◆ Indicates Parts Available In Assemblies Only)	PART #	QTY.
13	FITTING, 3/4FPT X 3/4MPT	014636	1
14	VALVE, 3/4 NPT ELBOW 3/4 MALE OUTLET PVC	014100	1
15	FILTER, WATER LUBE	016086	1
16	REDUCER, 5/8NPT/3/8 BARB WATER LUBE	014113	1
17	TUBING, WATER LUBE	R01885	2.1 m

1.16 Blade Lube System

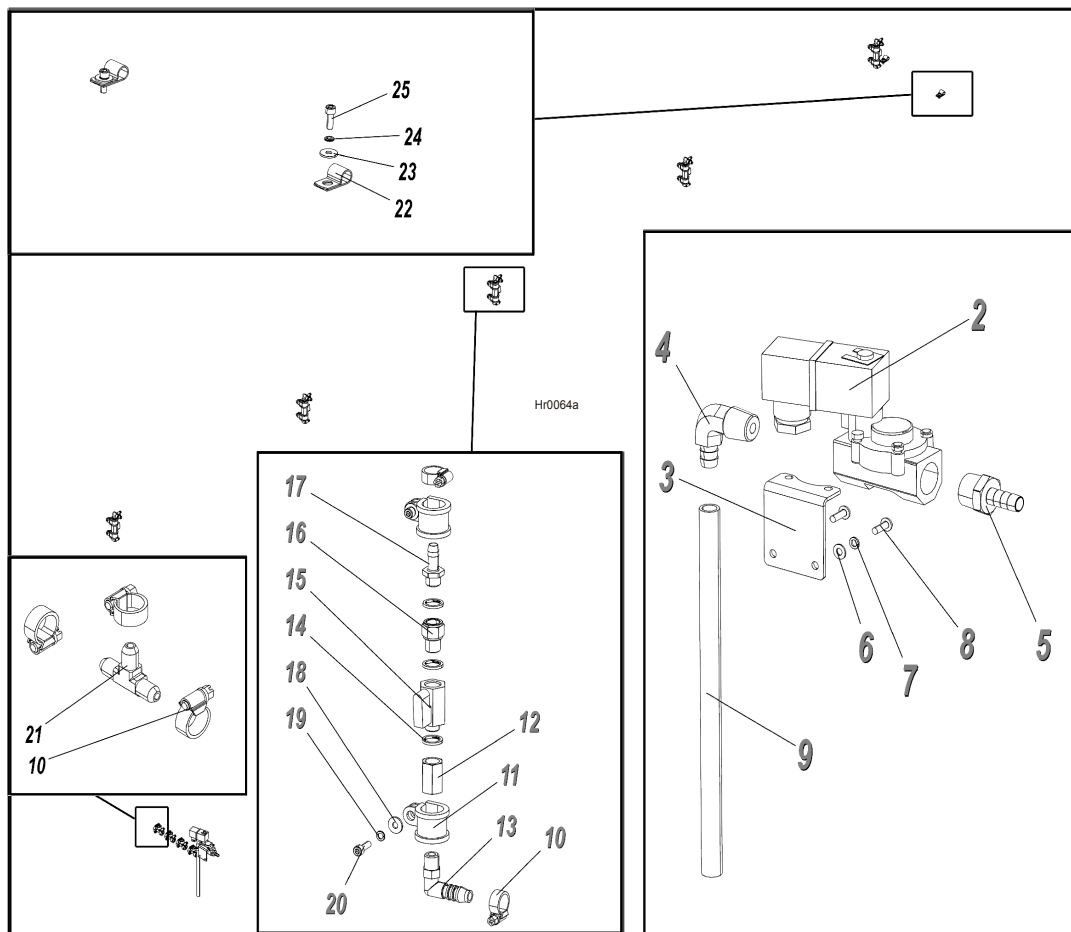

REF.	DESCRIPTION (◆ Indicates Parts Available In Assemblies Only)	PART #	QTY.
	BLADE LUBE KIT, HR700 (1 SAW HEAD)	509710	1 / 0 / 0 / 0 / 0 / 0
	BLADE LUBE KIT, HR700 (2 SAW HEADS)	509711	0 / 1 / 0 / 0 / 0 / 0
	BLADE LUBE KIT, HR700 (3 SAW HEADS)	509712	0 / 0 / 1 / 0 / 0 / 0
	BLADE LUBE KIT, HR700 (4 SAW HEADS)	509713	0 / 0 / 0 / 1 / 0 / 0
	BLADE LUBE KIT, HR700 (5 SAW HEADS)	509714	0 / 0 / 0 / 0 / 1 / 0
	BLADE LUBE KIT, HR700 (6 SAW HEADS)	509715	0 / 0 / 0 / 0 / 0 / 1
1	SOLENOID VALVE, BLADE LUBE SYSTEM - COMPLETE	509702	1 / 1 / 1 / 1 / 1 / 1
2	VALVE, ASCO SCE238A002 24VDC SOLENOID	510270	1

1

REPLACEMENT PARTS

Blade Lube System

3	BRACKET, SOLENOID VALVE ZINC-PLATED	092870-1	1	
4	FITTING, 1/2NPT-3/8 BARB ELBOW	P12707	1	
5	FITTING, 1/2" HOSE END	092356	1	
6	WASHER, 4.3 FLAT ZINC	F81051-2	2	
7	WASHER, Z 4.1 SPLIT LOCK ZINC	F81051-1	2	
8	SCREW, M4X12-5.8-B CROSS RECESSED PAN HEAD ZINC	F81011-43	2	
9	TUBING, 3/8" - 1 SAW HEAD	509704	1 / 0 / 0 / 0 / 0 / 0	
	TUBING, 3/8" - 2 SAW HEADS	509705	0 / 1 / 0 / 0 / 0 / 0	
	TUBING, 3/8" - 3 SAW HEADS	509706	0 / 0 / 1 / 0 / 0 / 0	
	TUBING, 3/8" - 4 SAW HEADS	509707	0 / 0 / 0 / 1 / 0 / 0	
	TUBING, 3/8" - 5 SAW HEADS	509708	0 / 0 / 0 / 0 / 1 / 0	
	TUBING, 3/8" - 6 SAW HEADS	509709	0 / 0 / 0 / 0 / 0 / 1	
10	CLAMP, 12-20MM DIA.	F81080-3	3 / 8 / 13 / 18 / 23 / 28	
11	CLIP, RSGU 1.20/20 W1 RETAINING	F81087-2	2 / 4 / 6 / 8 / 10 / 12	
12	SLEEVE, G1/4W/G1/4W 1823300001	090808	1 / 2 / 3 / 4 / 5 / 6	
13	FITTING, WES 10/R 1/4 ELBOW	088379	1 / 2 / 3 / 4 / 5 / 6	
14	SEAL, G1/4 866-014-000-0	090809	3 / 6 / 9 / 12 / 15 / 18	
15	VALVE, FP60.KIT 28 G1/4	088380	1 / 2 / 3 / 4 / 5 / 6	
16	ADAPTER, 2521 1/4-1/4 (CAMOZZI)	097704	1 / 2 / 3 / 4 / 5 / 6	
17	BUSHING, GT13/09 NR 13539	092783	1 / 2 / 3 / 4 / 5 / 6	
18	WASHER, 5.5 SPECIAL FLAT ZINC	F81052-3	2 / 4 / 6 / 8 / 10 / 12	
19	WASHER, 5.1 SPLIT LOCK	F81052-2	2 / 4 / 6 / 8 / 10 / 12	
20	SCREW, M5X16-8.8 HEX SOCKET HEAD CAP ZINC	F81000-25	2 / 4 / 6 / 8 / 10 / 12	
21	FITTING, 3/8 BARB TEE	015485	0 / 1 / 2 / 3 / 4 / 5	
22	CLAMP, 1/2" EMT COATED	P07584	2 / 0 / 2 / 0 / 2 / 0	
23	WASHER, 6.5 SPECIAL FLAT ZINC	F81053-11	2 / 0 / 2 / 0 / 2 / 0	
24	WASHER, Z 6.1 SPLIT LOCK	F81053-3	2 / 0 / 2 / 0 / 2 / 0	
25	SCREW, M6X16 8.8 HEX SOCKET HEAD CAP ZINC	F81001-21	2 / 0 / 2 / 0 / 2 / 0	

1.17 HR700 Saw Head Warning Decals

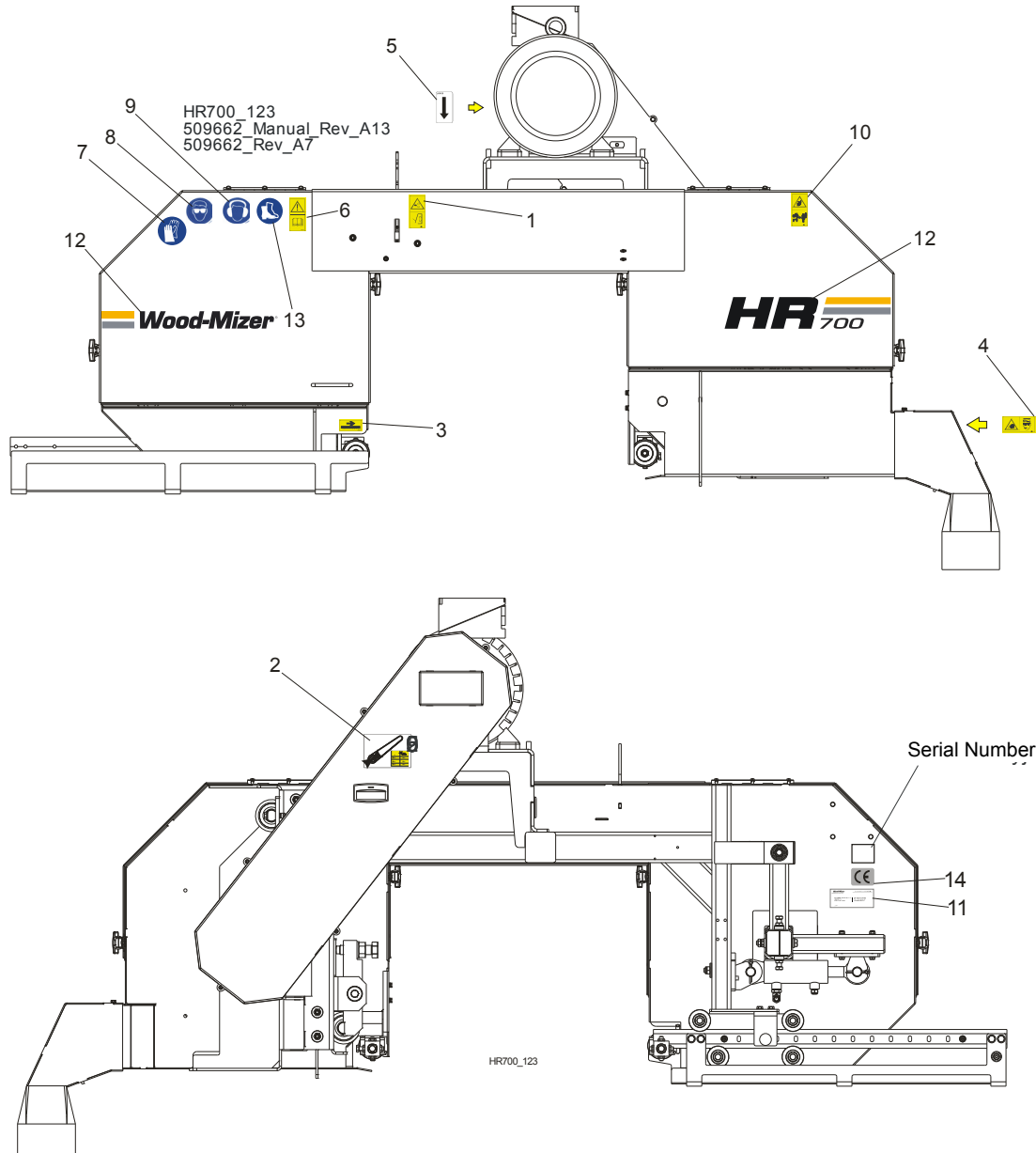

REF.	DESCRIPTION (◆ Indicates Parts Available In Assemblies Only)	PART #	QTY.
	DECAL KIT, HR700 - FOR 1 SAW HEAD	514207	1
1	DECAL "CLOSE ALL GUARDS AND COVERS BEFORE STARTING THE MACHINE"	099220	1
2	DECAL, DRIVE-SIDE WHEEL DIAMETER, LINEAR BLADE SPEED	509025	1
3	DECAL, BLADE MOVEMENT DIRECTION (PICTOGRAM)	096321	1
4	DECAL, SAWDUST CHUTE WARNING (PICTOGRAM)	099222	1
5	DECAL, MOTOR REVOLUTIONS DIRECTION	S20097	1
6	DECAL, READ THE OPERATOR'S MANUAL (PICTOGRAM)	096317	2
7	DECAL, WEAR SAFETY GLOVES (PICTOGRAM)	512107	1

1

REPLACEMENT PARTS

HR700 Saw Head Warning Decals

8	DECAL, EYE WARNING (PICTOGRAM)	S12004G	2	
9	DECAL, EAR WARNING (PICTOGRAM)	S12005G	2	
10	DECAL, KEEP A SAFE DISTANCE AWAY(PICTOGRAM)	099221	1	
11	DECAL, EUROPEAN HEADQUARTERS ADDRESS	015841	1	
12	DECAL KIT, HR700 NAME	514076	1	
13	DECAL, USE SAFETY BOOTS (PICTOGRAM)	501465	2	
14	DECAL, CE CERTIFIED MACHINE (SMALL)	P85070	1	
	DECAL KIT, HR700-1	514201	1	
	DECAL KIT, HR700 - FOR 1 SAW HEAD	514207	2	
	DECAL, COMPRESSED AIR IN THE SYSTEM EVEN AFTER ELECTRIC POWER DISCONNECTION	101176 ¹	1	
	DECAL, PNEUMATIC SYSTEM PRESSURE VALUE	513181 ¹	1	
	DECAL KIT, HR700-2	514202	1	
	DECAL KIT, HR700 - FOR 1 SAW HEAD	514207	2	
	DECAL, COMPRESSED AIR IN THE SYSTEM EVEN AFTER ELECTRIC POWER DISCONNECTION	101176 ¹	1	
	DECAL, PNEUMATIC SYSTEM PRESSURE VALUE	513181 ¹	1	
	DECAL KIT, HR700-3	514203	1	
	DECAL KIT, HR700 - FOR 1 SAW HEAD	514207	3	
	DECAL, COMPRESSED AIR IN THE SYSTEM EVEN AFTER ELECTRIC POWER DISCONNECTION	101176 ¹	1	
	DECAL, PNEUMATIC SYSTEM PRESSURE VALUE	513181 ¹	1	
	DECAL KIT, HR700-4	514204	1	
	DECAL KIT, HR700 - FOR 1 SAW HEAD	514207	4	
	DECAL, COMPRESSED AIR IN THE SYSTEM EVEN AFTER ELECTRIC POWER DISCONNECTION	101176 ¹	1	
	DECAL, PNEUMATIC SYSTEM PRESSURE VALUE	513181 ¹	1	
	DECAL KIT, HR700-5	514205	1	
	DECAL KIT, HR700 - FOR 1 SAW HEAD	514207	5	
	DECAL, COMPRESSED AIR IN THE SYSTEM EVEN AFTER ELECTRIC POWER DISCONNECTION	101176 ¹	1	
	DECAL, PNEUMATIC SYSTEM PRESSURE VALUE	513181 ¹	1	
	DECAL KIT, HR700-6	514206	1	
	DECAL KIT, HR700 - FOR 1 SAW HEAD	514207	6	
	DECAL, COMPRESSED AIR IN THE SYSTEM EVEN AFTER ELECTRIC POWER DISCONNECTION	101176 ¹	1	
	DECAL, PNEUMATIC SYSTEM PRESSURE VALUE	513181 ¹	1	

¹ See Section 1.18

1.18 Pneumatic System Decals

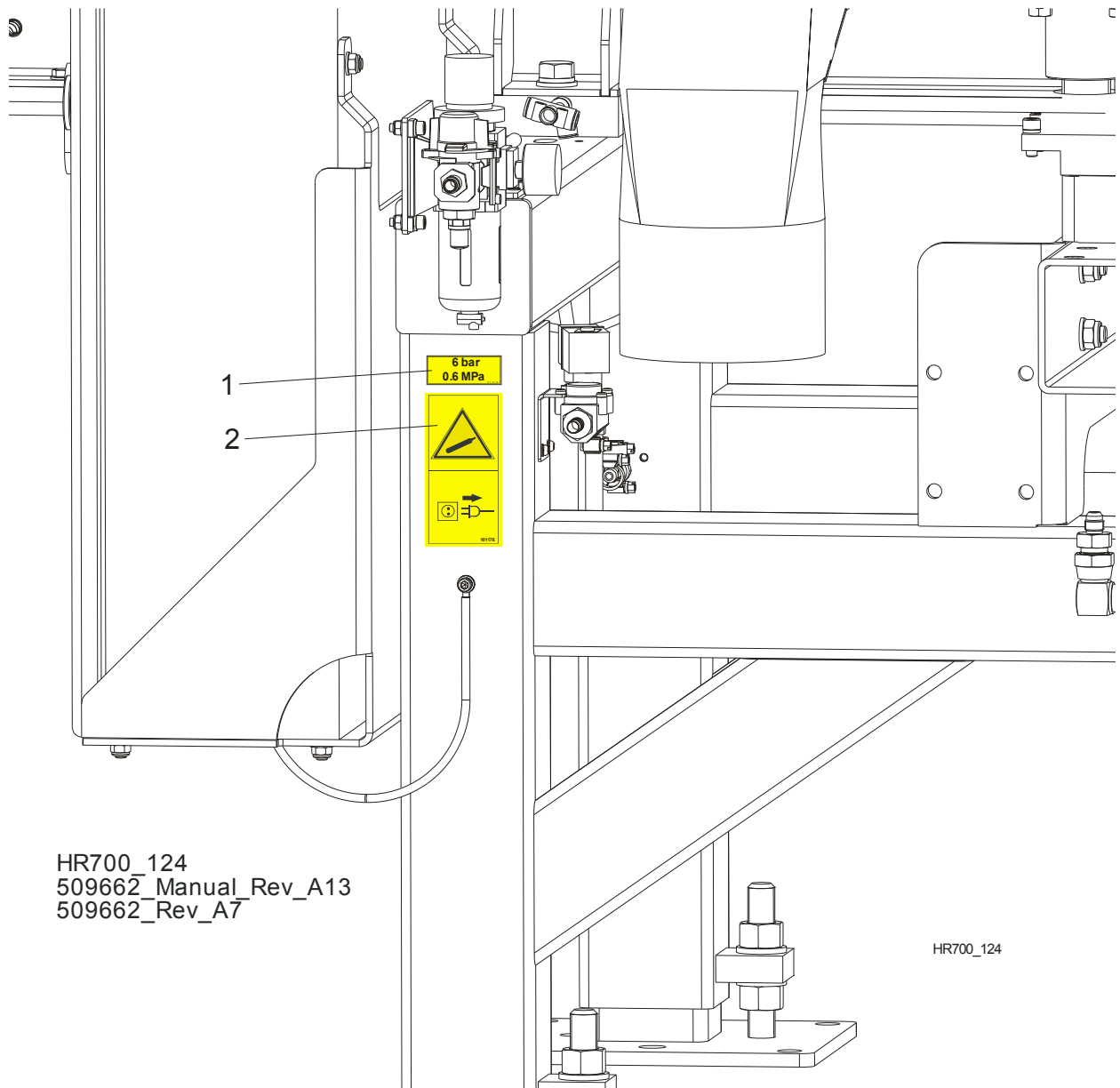

HR700_124
 509662_Manual_Rev_A13
 509662_Rev_A7

HR700_124

REF.	DESCRIPTION (◆ Indicates Parts Available In Assemblies Only)	PART #	QTY.
1	DECAL, COMPRESSED AIR IN THE SYSTEM EVEN AFTER ELECTRIC POWER DISCONNECTION	101176	1
2	DECAL, PNEUMATIC SYSTEM PRESSURE VALUE	513181	1

1 REPLACEMENT PARTS

HR700 Saw Head

1.19 HR700 Saw Head

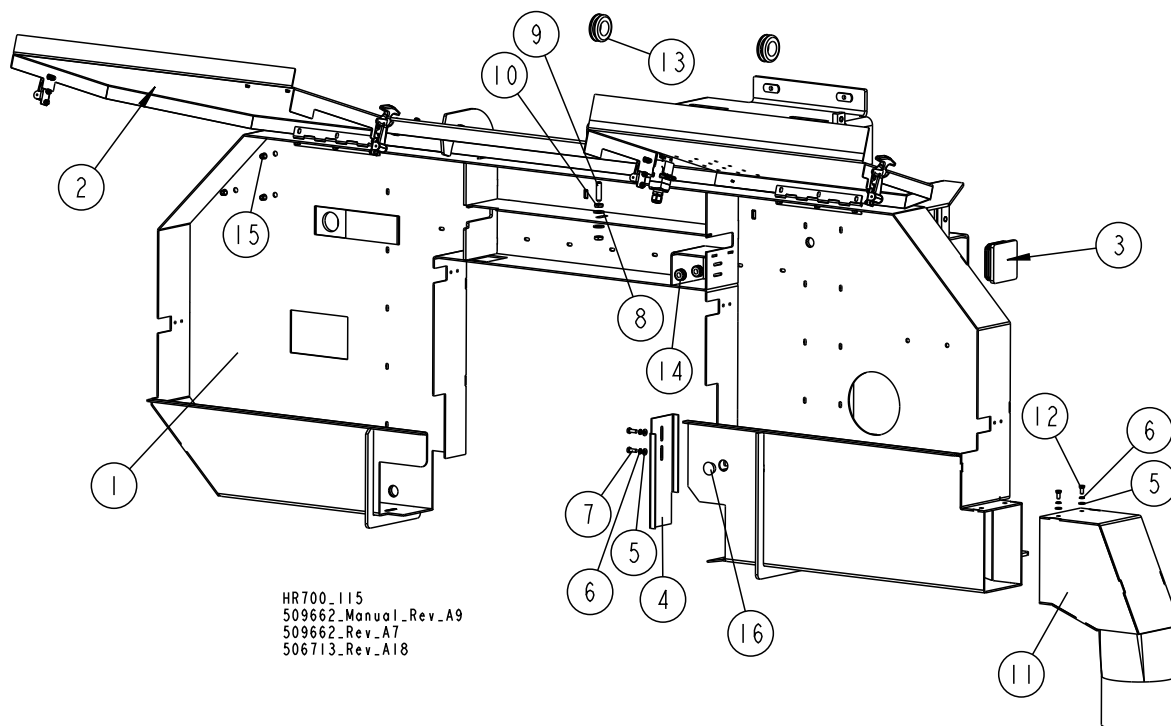

REF.	DESCRIPTION (◆ Indicates Parts Available In Assemblies Only)	PART #	QTY.
1	SAW HEAD, SHS/HR700	506714-1	1
2	COVER, SHS/HR700 FRONT - COMPLETE See Section 1.20	506762	1
3	CAP, 80X80 GR 2-4 #111227 TUBE END	089644	4
4	GUARD, BLADE GUIDE ROLLER	094737-1	1
5	WASHER, 6.4 FLAT ZINC	F81053-1	4
6	WASHER, Z 6.1 SPLIT LOCK	F81053-3	4
7	BOLT, M6X16-8.8 HEX HEAD FULL THREAD ZINC	F81001-15	2
8	WASHER, 10.5 FLAT ZINC	F81055-1	2
9	SCREW, M10X40-45H HEX SOCKET SET CONE POINT ZINC	F81003-61	1
10	NUT, M10-04-A ZINC-PLATED THIN	F81033-6	2
11	CHUTE, RESAW SAWDUST	094059-1	1
12	BOLT, M6X12 8.8 HEX HEAD FULL THREAD ZINC	F81001-7	2
13	GROMMET, 30X42X8 RUBBER	509717	2
14	GROMMET, 3/8" ID RUBBER	025248	2
15	PLUG, SR1086-9.5 #46009 (MOSS) BLANKING	096846	3
16	PLUG, SR1086 22.2 HOLE	093544	1

1.20 Front Blade Housing Cover

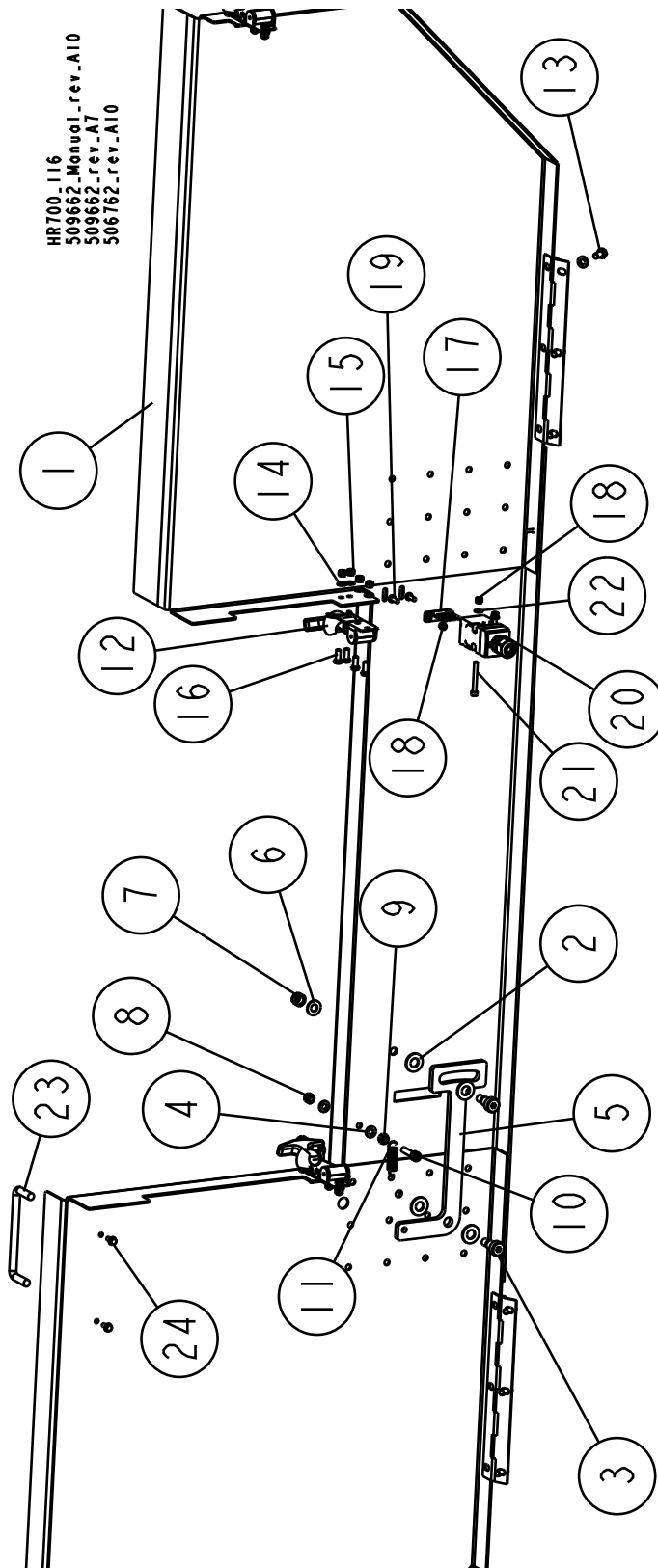

1 REPLACEMENT PARTS

Front Blade Housing Cover

REF.	DESCRIPTION (◆ Indicates Parts Available In Assemblies Only)	PART #	QTY.	
	COVER, SHS/HR700 FRONT - COMPLETE	506762	1	
1	COVER, SHS/HR700 FRONT	506763-1	1	
2	WASHER, 10.5 FLAT ZINC	F81055-1	4	
3	BOLT, 10/M8X12-12.9 BOSSARD SHOULDER	F81003-62	2	
4	WASHER, 6.4 FLAT ZINC	F81053-1	8	
5	PAWL, LOCKING	090643-1	1	
6	WASHER, 8.4 FLAT ZINC	F81054-1	2	
7	NUT, M8 8 HEX NYLON ZINC LOCK	F81032-2	2	
8	NUT, M6-8-B HEX NYLON ZINC LOCK	F81031-2	1	
9	NUT, M6 8 HEX ZINC	F81031-1	1	
10	SCREW, M6X25-8.8 HEX SOCKET HEAD CAP ZINC	F81001-41	1	
11	SPRING, 1.6X12X38 EXTENSION	092208	1	
12	LATCH, FLEXIBLE DRAW	014829	4	
13	BOLT, M6X12 8.8 HEX HEAD FULL THREAD ZINC	F81001-7	6	
14	WASHER, 5.3 FLAT ZINC	F81052-1	16	
15	NUT, M5-8 DIN985 ZINC-PLATED	F81030-2	16	
16	BOLT, M5X12 5.8 HEX HEAD FULL THREAD ZINC	F81000-5	16	
17	KEY, AZ17/170-B5 SAFETY SWITCH	094422	1	
18	NUT, M4-8 HEX NYLON ZINC LOCK	F81029-1	4	
19	SCREW, M4X12-5.8-B CROSS RECESSED PAN HEAD ZINC	F81011-43	2	
20	SWITCH, AZ17-11ZRK SAFETY	094232	1	
21	SCREW, M4X35 8.8 HEX SOCKET HEAD CAP ZINC	F81011-34	2	
22	WASHER, 4.3 FLAT ZINC	F81051-2	2	
23	HANDLE, 4"	P08065	1	
24	SCREW, #8-32X3/8 SELF-TAPPING	F05015-8	2	

1.21 Adjustable Saw Head Guide Rollers

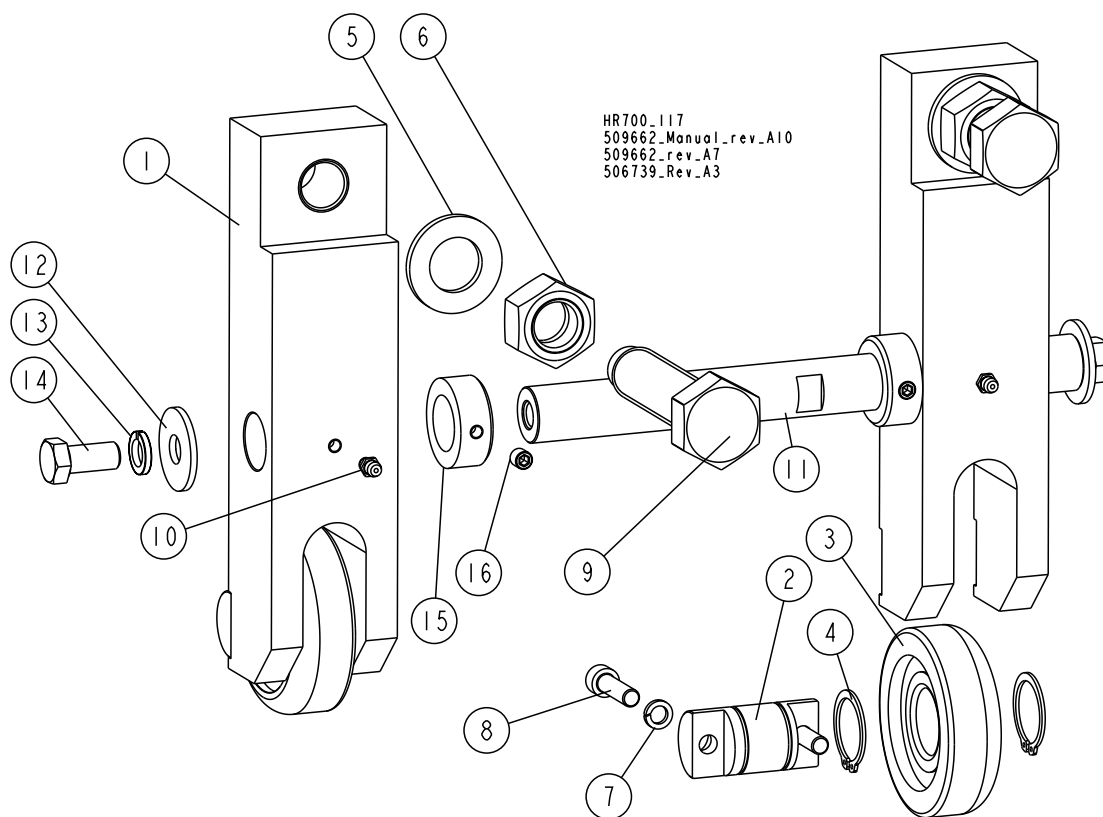

REF.	DESCRIPTION (◆ Indicates Parts Available In Assemblies Only)	PART #	QTY.
	ROLLER ASSEMBLY, ADJUSTABLE SAW HEAD GUIDE	506739	1
1	BAR, ROLLER ZINC-PLATED MOUNT	506741-1	2
2	SHAFT, GUIDE ROLLER ZINC-PLATED	506742-1	2
3	ROLLER, SBBA3084-01 (COMPLEX)	088433	2
4	RING, 30Z OUTSIDE RETAINING	F81090-23	4
5	WASHER, 25 FLAT ZINC	F81061-3	2
6	NUT, M24X2-8-B HEX ZINC	F81039-11	2
7	WASHER, 8.2 SPLIT LOCK ZINC	F81054-4	4
8	SCREW, M8X30-8.8 HEX SOCKET HEAD CAP ZINC	F81002-31	4
9	BOLT, M24X2X95 ZINC-PLATED SPECIAL	506748-1	2
10	FITTING, M6 STRAIGHT GREASE	086280	2
11	ROD, GUIDE ROLLER CONNECTION	506747-1	1
12	WASHER, 13 SPECIAL FLAT ZINC	F81056-14	2
13	WASHER, Z12.2 SPLIT LOCK ZINC	F81056-2	2
14	BOLT, M12X25-8.8 HEX HEAD FULL THREAD ZINC	F81004-31	2
15	RING, 25 STOPPING LIGHT TYPE	F81039-4	2
16	SCREW, M8X8-33H HEX SOCKET FLAT POINT ZINC SET	F81014-1	2

1 REPLACEMENT PARTS

Fixed Saw Head Guide Rollers

1.22 Fixed Saw Head Guide Rollers

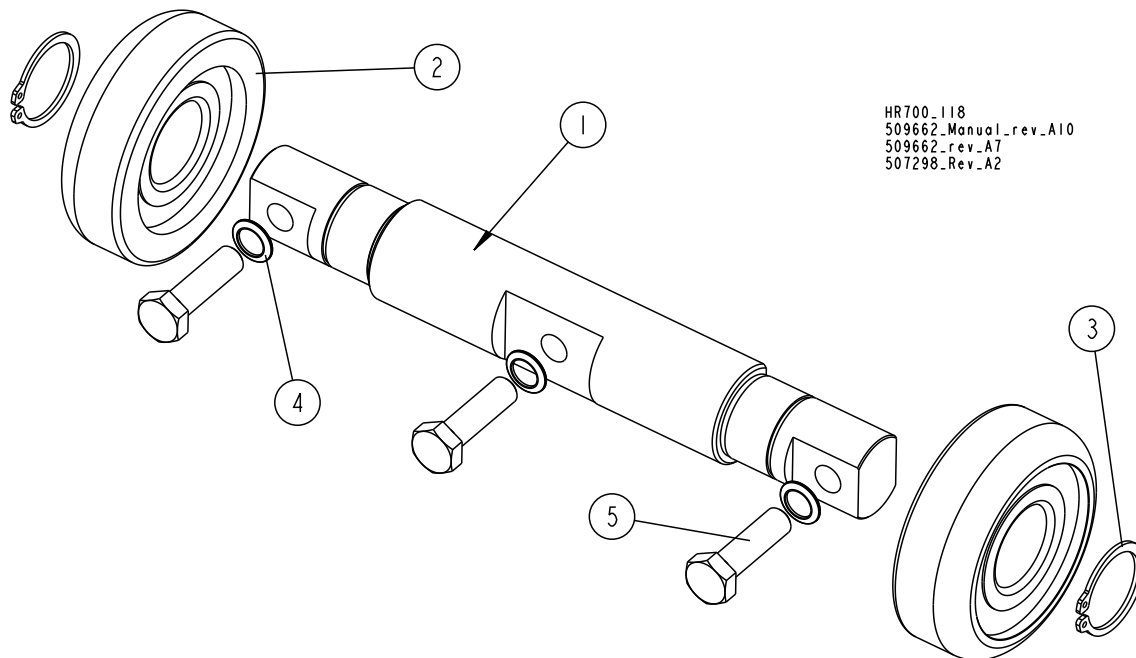

REF.	DESCRIPTION (◆ Indicates Parts Available In Assemblies Only)	PART #	QTY.
	ROLLER ASSEMBLY, FIXED SAW HEAD GUIDE	507298	1
1	SHAFT, FIXED GUIDE ROLLER ZINC-PLATED	088815-1	1
2	ROLLER, SBBA3084-01 (COMPLEX)	088433	2
3	RING, 30Z OUTSIDE RETAINING	F81090-23	2
4	WASHER, 791 M10/10.5 SPLIT LOCK	F81055-7	3
5	BOLT, M10X35 8.8 HEX HEAD FULL THREAD ZINC	F81003-17	3

1.23 HR700 Vertical Mast

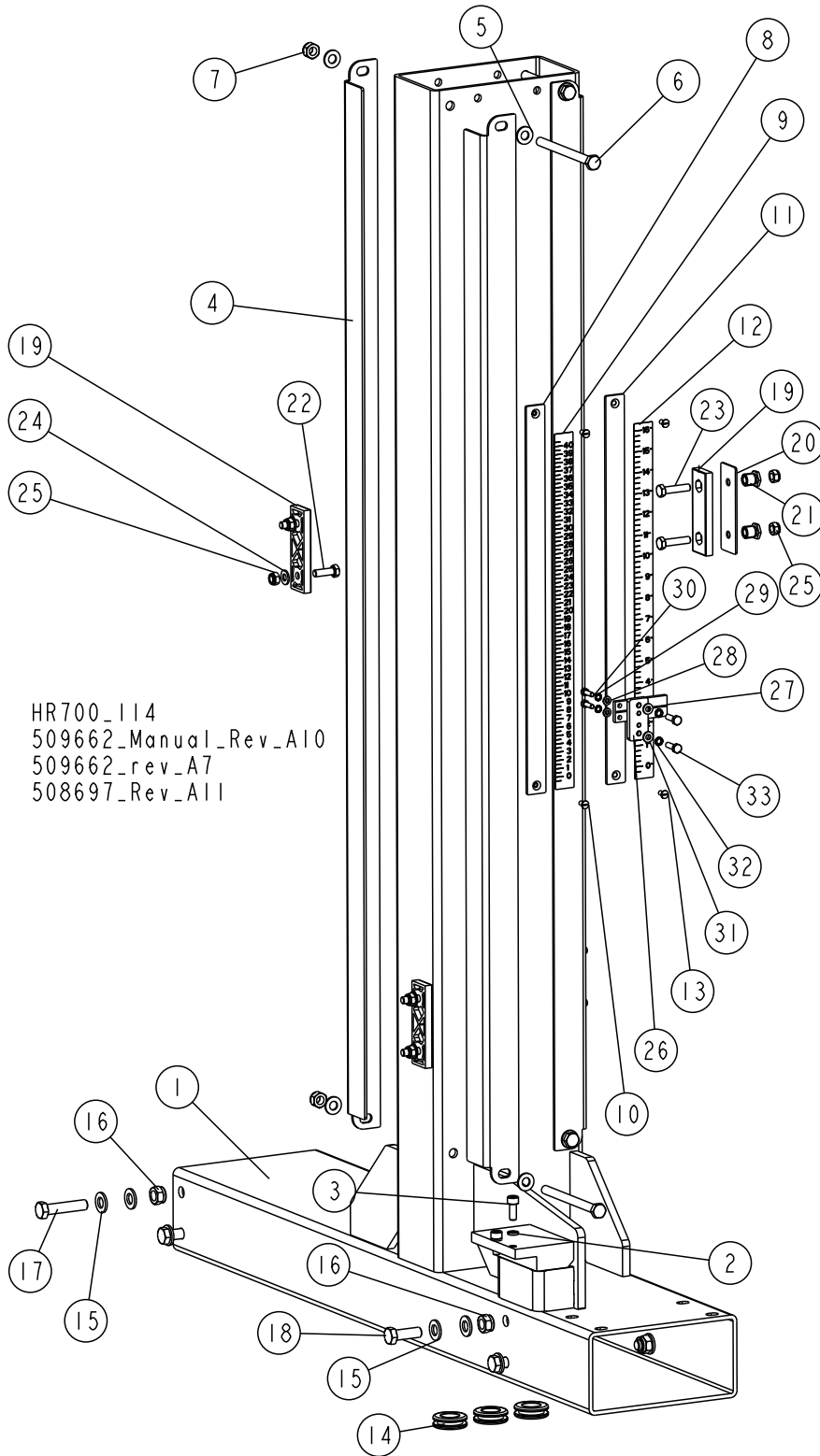

HR700_114
509662_Manual_Rev_A10
509662_rev_A7
508697_Rev_A11



REPLACEMENT PARTS

HR700 Vertical Mast

REF.	DESCRIPTION (◆ Indicates Parts Available In Assemblies Only)	PART #	QTY.
	MAST, HR700 COMPLETE	508697	1
1	MAST, HR700	508698-1	1
2	WASHER, 8.2 SPLIT LOCK ZINC	F81054-4	2
3	SCREW, M8X20-8.8 HEX SOCKET HEAD CAP ZINC	F81002-30	2
4	ANGLE, MAST TUBE	513489	4
5	WASHER, 10.5 FLAT ZINC	F81055-1	8
6	BOLT, M10X125 8.8 HEX HEAD ZINC	F81003-18	4
7	NUT, M10-8-B HEX NYLON ZINC LOCK	F81033-1	4
	SCALE, METRIC BLADE HEIGHT - COMPLETE	507302	1
8	BAR, SHS/HR700 BLADE HEIGHT SCALE	507303	1
9	DECAL, 0-40 METRIC BLADE HEIGHT SCALE	507304	1
10	SCREW, M5X12- 5.8-B SLOTTED COUNTERSUNK HEAD ZINC	F81000-15	2
	SCALE, INCH BLADE HEIGHT - COMPLETE	507305	1
11	BAR, SHS/HR700 BLADE HEIGHT SCALE	507303	1
12	DECAL, 0-15.75 INCH BLADE HEIGHT SCALE	507306	1
13	SCREW, M5X12- 5.8-B SLOTTED COUNTERSUNK HEAD ZINC	F81000-15	2
14	GROMMET, 22MM ID RUBBER	087400	6
15	WASHER, 13MM FLAT ZINC	F81056-1	16
16	NUT, M12-8 HEX NYLON ZINC LOCK	F81034-2	8
17	BOLT, M12X55-8.8 HEX HEAD ZINC	F81004-12	4
18	BOLT, M12X35 8.8 HEX HEAD FULL THREAD ZINC	F81004-24	4
19	PAD, DELRIN UP/DOWN SLIDE	M04096	4
20	PLATE, SLIDE PAD MOUNTING	093246-1	2
21	.NUT, SLIDE PAD ZINC-PLATED ADJUSTMENT	086683-1	4
22	BOLT, M8X25-8.8-B HEX HEAD FULL THREAD ZINC	F81002-5	4
23	BOLT, M8X35-8.8 HEX HEAD FULL THREAD ZINC	F81002-13	4
24	WASHER, 8.4 FLAT ZINC	F81054-1	4
25	NUT, M8 8 HEX NYLON ZINC LOCK	F81032-2	8
	INDICATOR, BLADE HEIGHT SCALE - COMPLETE	507299	1
26	PLATE, SCALE INDICATOR ZINC-PLATED MOUNTING	507301-1	1
27	INDICATOR, BLADE HEIGHT SCALE	094821	1
28	WASHER, 5.3 FLAT ZINC	F81052-1	2
29	WASHER, 5.1 SPLIT LOCK ZINC	F81052-2	2
30	BOLT, M5X16-5.8 HEX HEAD FULL THREAD ZINC	F81000-51	2
31	WASHER, 6.4 FLAT ZINC	F81053-1	2
32	WASHER, Z 6.1 SPLIT LOCK ZINC	F81053-3	2
33	BOLT, M6X20 8.8 HEX HEAD FULL THREAD ZINC	F81001-2	2

1.24 Drive Belt Guard

HR700_119
 509662_Manual_Rev_All
 509662_rev_A7
 506767_Rev_A4

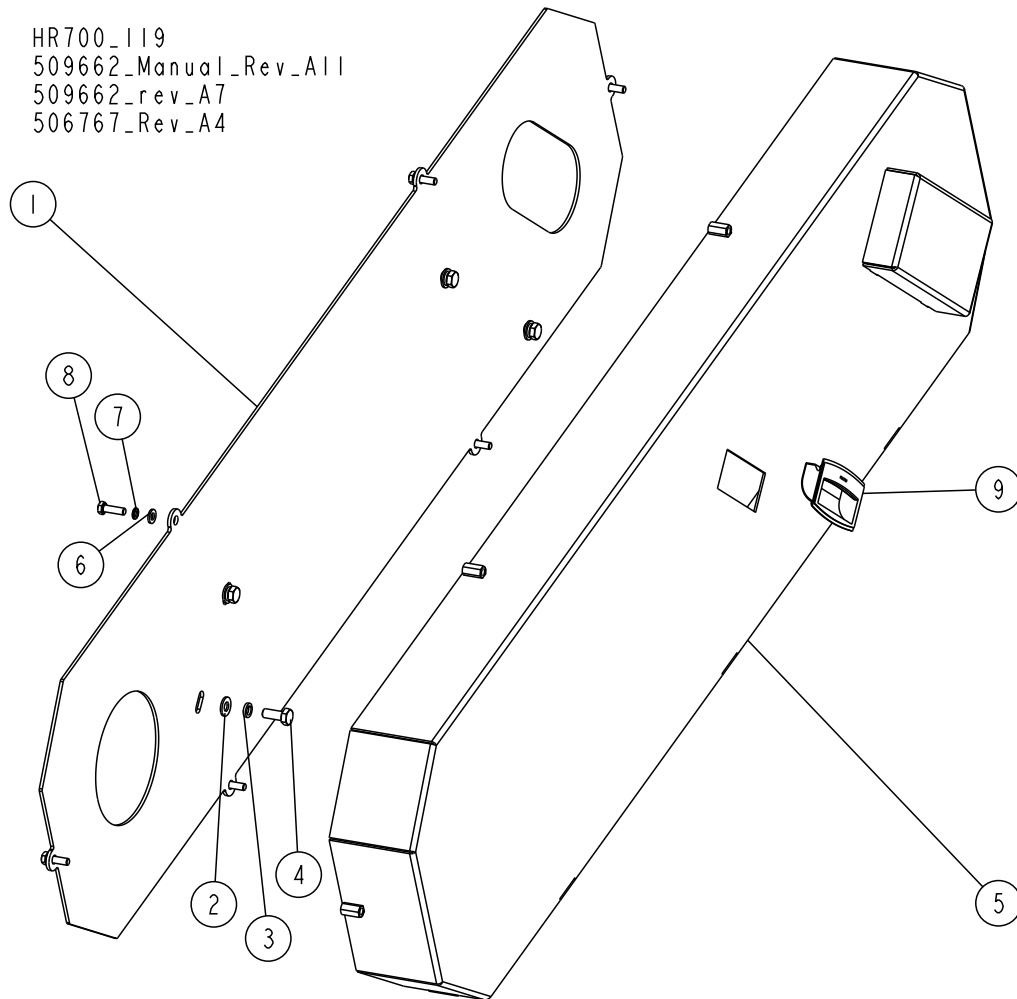

REF.	DESCRIPTION (◆ Indicates Parts Available In Assemblies Only)	PART #	QTY.
	GUARD, DRIVE BELT - COMPLETE	506767	1
1	PLATE, DRIVE BELT GUARD REAR	506731-1	1
2	WASHER, 8.4 FLAT ZINC	F81054-1	4
3	WASHER, 8.2 SPLIT LOCK ZINC	F81054-4	4
4	BOLT, M8X20 8.8 HEX HEAD FULL THREAD ZINC	F81002-4	4
5	GUARD, DRIVE BELT	506768-1	1
6	WASHER, 6.4 FLAT ZINC	F81053-1	6
7	WASHER, Z 6.1 SPLIT LOCK ZINC	F81053-3	6
8	BOLT, M6X20 8.8 HEX HEAD FULL THREAD ZINC	F81001-2	6
9	HANDLE, EPR.90-PF-C1(261051-C1) SNAP-IN FLUSH PULL	100012	1

1 REPLACEMENT PARTS

Blade Guide Arm

1.25 Blade Guide Arm

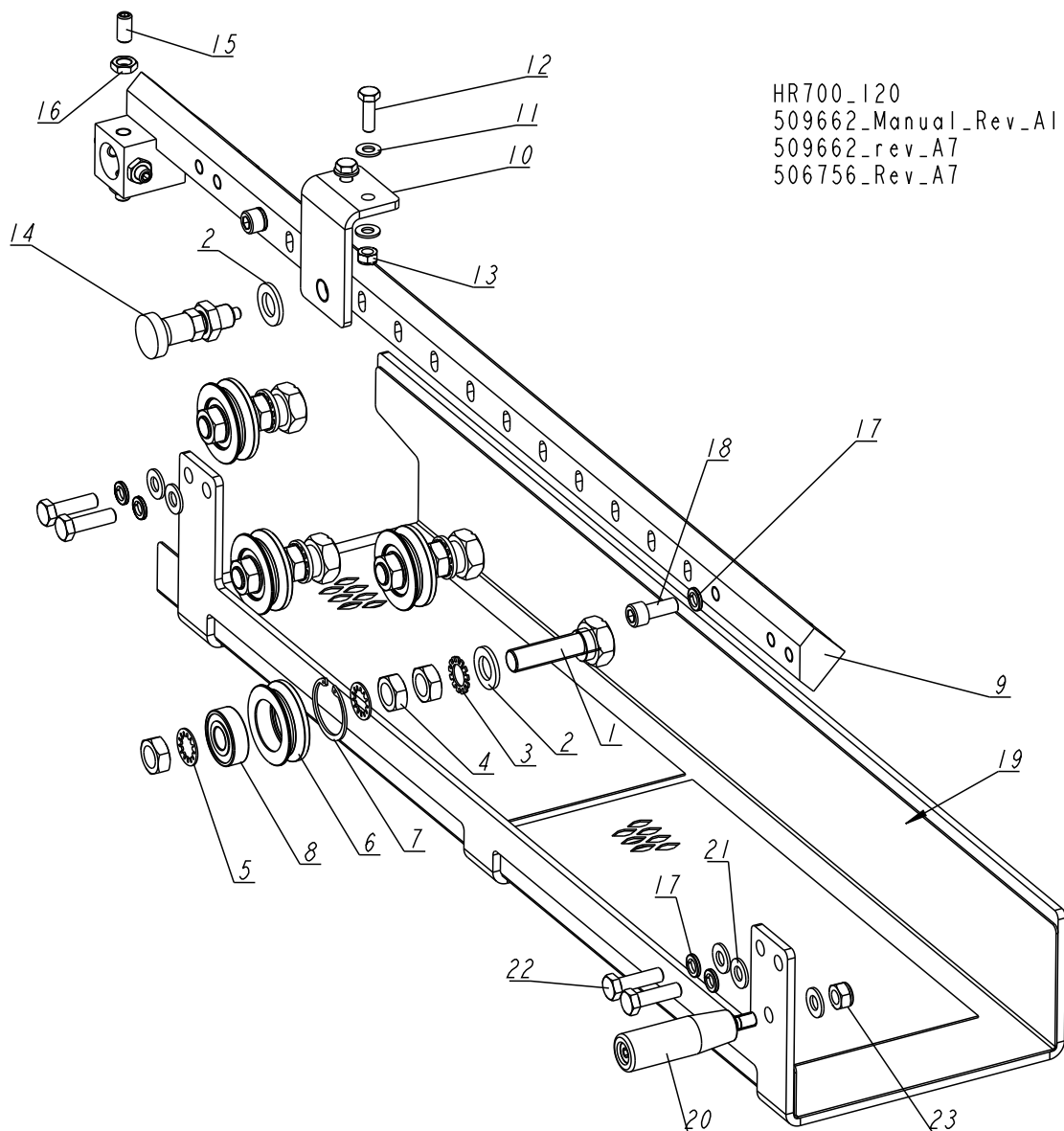

HR700_120
 509662_Manual_Rev_All
 509662_rev_A7
 506756_Rev_A7

REF.	DESCRIPTION (◆ Indicates Parts Available In Assemblies Only)	PART #	QTY.
	ARM, ADJUSTABLE BLADE GUIDE - COMPLETE	506756	1
1	BOLT WELDMENT, ECCENTRIC	086508-1	4
2	WASHER, 17 SPLIT LOCK ZINC	F81058-1	5
3	WASHER, 5/8" EXTERNAL STAR	F05011-26	4
4	NUT, 5/8"-18 HEX ZINC	F05010-11	12
5	WASHER, 5/8" INTERNAL STAR	F05011-25	8
	ROLLER ASSEMBLY, V-GROOVE W/BEARING	093855	4
6	ROLLER, V-GROOVE ZINC-PLATED	093856-1	1
7	RING, W40 INSIDE RETAINING	F81090-3	1
8	BEARING, 6203 2RSP6- 5/8 CX	095087	1

REPLACEMENT PARTS*Blade Guide Arm***1**

REF.	DESCRIPTION (◆ Indicates Parts Available In Assemblies Only)	PART #	QTY.	
9	ARM, BLADE GUIDE ZINC-PLATED	506757-1	1	
10	BRACKET, DETENT PIN MOUNT	099077-1	1	
11	WASHER, 8.4 FLAT ZINC	F81054-1	4	
12	BOLT, M8X25-8.8-B HEX HEAD FULL THREAD ZINC	F81002-5	2	
13	NUT, M8 8 HEX NYLON ZINC LOCK	F81032-2	2	
14	PIN, 45308DNW DETENT	089939	1	
15	SCREW, M10X1X20 DIN 913 STAINLESS STEEL SET	F81015-1	4	
16	NUT, M10X1-04-ST-A2E ISO8675 THIN	F81033-10	4	
17	WASHER, Z 10.2 SPLIT LOCK ZINC	F81055-2	6	
18	SCREW, M10X25 8.8 HEX SOCKET HEAD CAP ZINC	F81003-32	2	
19	GUARD, BLADE	506761-1	1	
20	KNOB, L=85 M10, RO11-M10 PLASTIC CRANK HANDLE	086338	1	
21	WASHER, 10.5 FLAT ZINC	F81055-1	5	
22	BOLT, M10X35 8.8 HEX HEAD FULL THREAD ZINC	F81003-17	4	
23	NUT, M10-8-B HEX NYLON ZINC LOCK	F81033-1	1	

1 REPLACEMENT PARTS

E20 (Standard) & E25 (Option) Motors

1.26 E20 (Standard) & E25 (Option) Motors

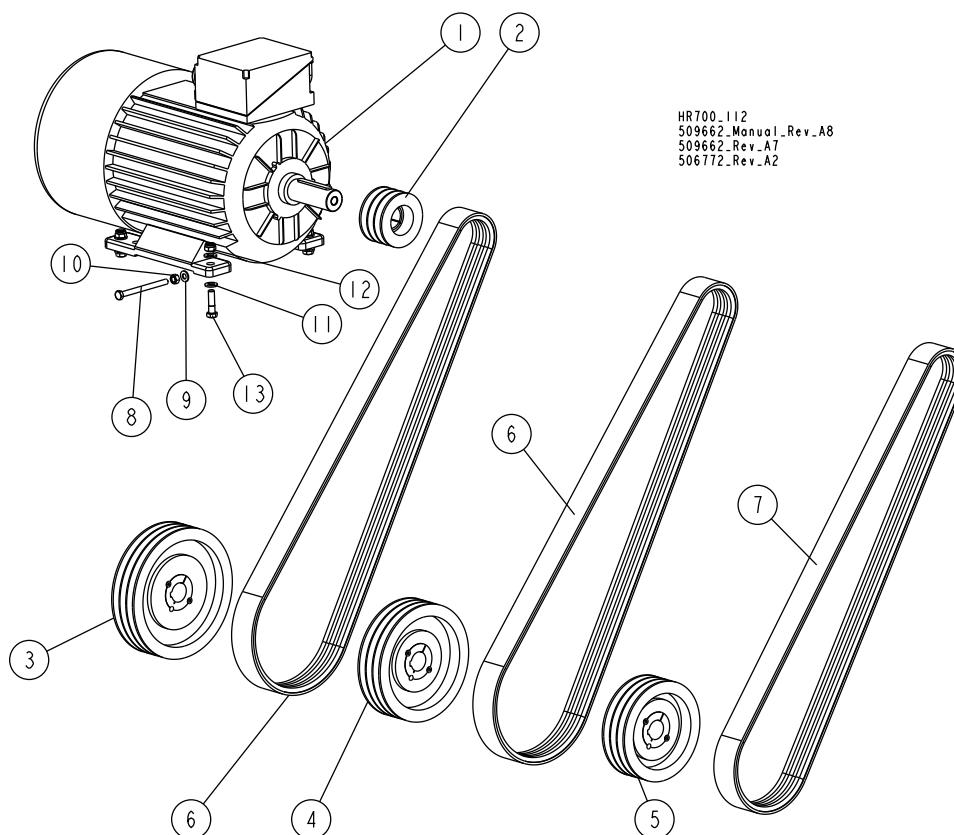

REF.	DESCRIPTION (◆ Indicates Parts Available In Assemblies Only)	PART #	QTY.
	MOTOR, E25 SHS/HR700 MAIN - COMPLETE	506771	1/0
	MOTOR, E20 SHS/HR700 MAIN - COMPLETE	506772	0/1
1	MOTOR, PSG-160 L4 18,5KW + H-160+	508712	1/0
	MOTOR, 2SIE-160 L4 400 50HZ+H160 15KW 1460 1/MIN.	507317	0/1
2	PULLEY, PBT SPB3 100/42, (F02313+T31081)	506753 ^{1 2 3}	1
3	PULLEY, PBT SPB3 250/38, (F01816+T31138)	507273 ²	1
4	PULLEY, PBT SPB3 224/38, (F01876+T31124)	506755 ¹	1
5	PULLEY, PBT SPB3 190/38, (F01802+T31124)	506754 ³	1
6	V-BELT, 3B HB2240	088993 ^{1 2}	2
7	V-BELT, 3B HB2160	507311 ³	1
8	BOLT, M10X120-8.8 HEX HEAD FULL THREAD ZINC	F81003-47	2
9	WASHER, 10.5 FLAT ZINC	F81055-1	2
10	NUT, M10 8 HEX ZINC	F81033-3	2
11	WASHER, 13 FLAT ZINC	F81056-1	8
12	NUT, M12 8 HEX NYLON ZINC LOCK	F81034-2	4
13	BOLT, M12X45 8.8 HEX HEAD ZINC	F81004-32	4

¹ For standard blade speed of V=20m/s, mount pulley #506753 on motor shaft, and pulley #506755 with belt #088993 on drive shaft.

² For optional blade speed of V=18m/s, mount pulley #506753 on motor shaft, and pulley #507273 with belt #088993 on drive shaft.

³ For optional blade speed of V=24m/s, mount pulley #506753 on motor shaft, and pulley #506754 with belt #507311 on drive shaft.

1.27 E15 Motor Assembly (Option)

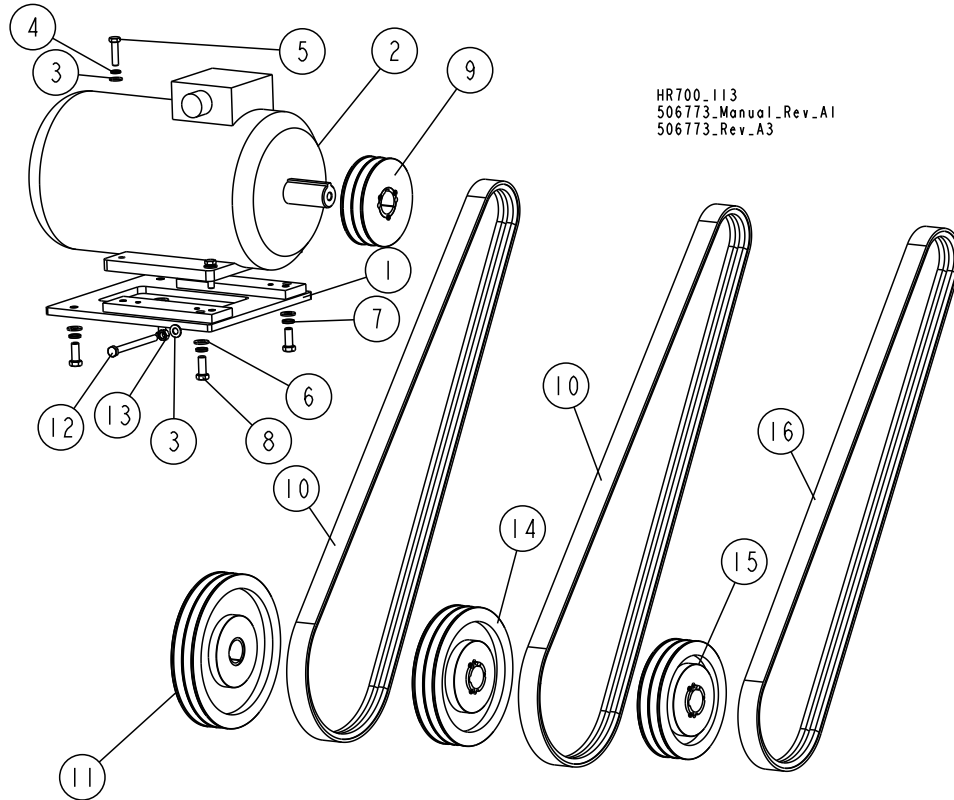

HR700_113
506773_Manual_Rev_A1
506773_Rev_A3

REF.	DESCRIPTION (◆ Indicates Parts Available In Assemblies Only)	PART #	QTY.
	MOTOR, E15 SHS/HR700 MAIN - COMPLETE	506773	1
1	PLATE, E15 HR-L MOTOR MOUNT	506774-1	1
2	MOTOR, SG132M-4PC-HM (11KW,1500 r.p.m.)	093219	1
3	WASHER, 10.5 FLAT ZINC	F81055-1	6
4	WASHER, Z 10.2 SPLIT LOCK ZINC	F81055-2	4
5	BOLT, M10X40-8.8 HEX HEAD FULL THREAD ZINC	F81003-16	4
6	WASHER, 13 FLATZINC	F81056-1	4
7	WASHER, Z12.2 SPLIT LOCK ZINC	F81056-2	4
8	BOLT, M12X30 8.8 HEX HEAD FULL THREAD ZINC	F81004-22	4
9	PULLEY, SPB-B-5VN100X2CGROOVES/N38(F02312+T31079)	500176 ^{1 2 3}	1
10	V-BELT, 2B HB2240	507307 ^{1 2}	2
11	PULLEY, SPB-B-5VN250X2 GROOVES /N38 (F02365+T31124)	507274 ²	1
12	BOLT, M10X120-8.8 HEX HEAD FULL THREAD ZINC	F81003-47	2
13	NUT, M10 8 HEX ZINC	F81033-3	2
14	PULLEY, SPB-B-5VN224X2 GROOVES /N38 (F02359+T31124)	500177	1
15	PULLEY, SPB-B-5V N190X 2 GROOVES /N38(F02347+T31124)	500569 ³	1
16	V-BELT, 2B HB2160	507315 ³	1

¹ For standard blade speed of V=20m/s, mount pulley #500176 on motor shaft, and pulley #500177 with belt #507307 on drive shaft.

² For optional blade speed of V=18m/s, mount pulley #500176 on motor shaft, and pulley #507274 with belt #507307 on drive shaft.

³ For optional blade speed of V=24m/s, mount pulley #500176 on motor shaft, and pulley #500569 with belt #507315 on drive shaft.

1 REPLACEMENT PARTS

Feed Chain Drive & Tensioner

1.28 Feed Chain Drive & Tensioner

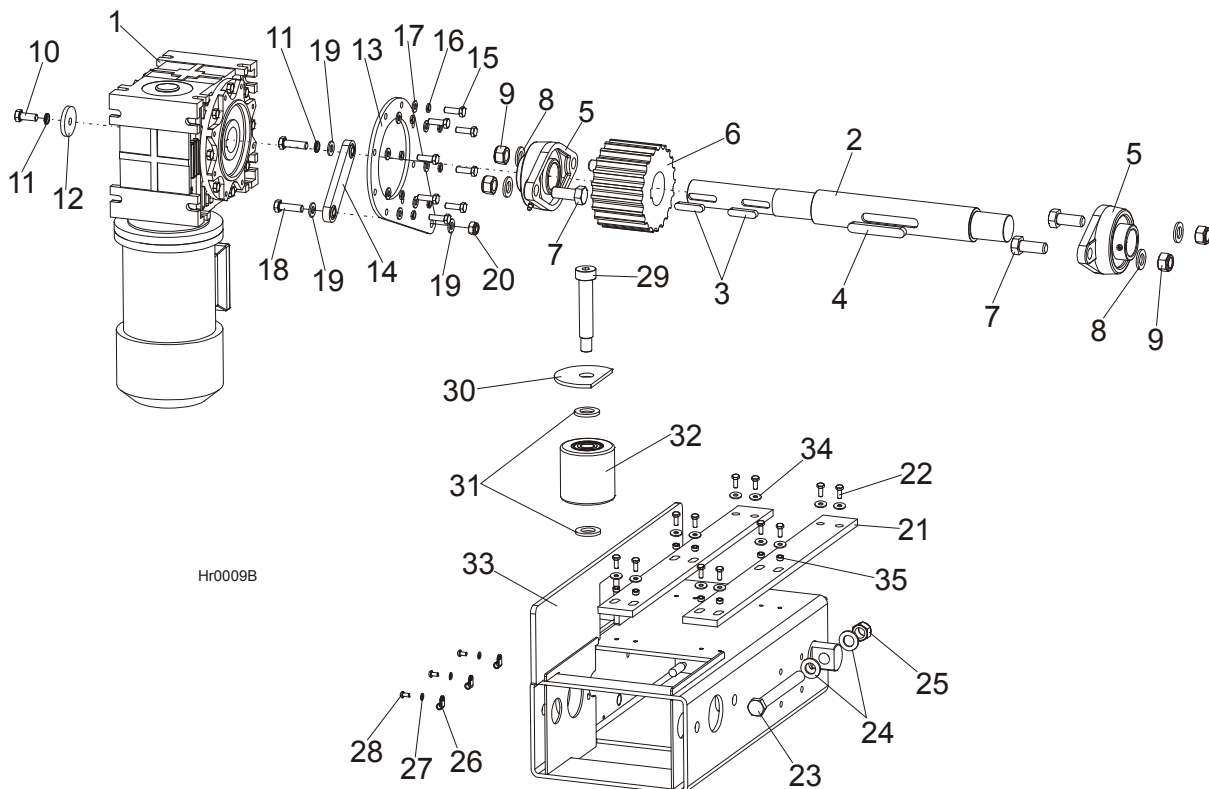

REF.	DESCRIPTION (◆ Indicates Parts Available In Assemblies Only)	PART #	QTY.
	DRIVE ASSEMBLY, HR FEED CHAIN	099377	1
	DRIVE ASSEMBLY, HR FEED CHAIN	099069	1
1	MOTOREDUCER, MR-80/42/1,1-1400/K4/V6	099070	1
	MOTOR, 1.1kW 1400 r.p.m.	086530	1
2	SHAFT, ZINC-PLATED DRIVE	099335-1	1
3	KEY, A10x8x45 PARALLEL	091312	2
4	KEY, A14X9X90 PARALLEL	099424	1
5	BEARING, UCFL208 W/HOUSING	099423	2
6	SPROCKET, KZN800/21-40 A=80 B=40	099079	1
7	BOLT, M16x40-8.8 HEX HEAD FULL THREAD ZINC	F81006-13	4
8	WASHER, 17 FLAT ZINC	F81058-1	4
9	NUT, M16-8 HEX NYLON ZINC LOCK	F81036-2	4
10	BOLT, M10x25-8.8 HEX HEAD FULL THREAD ZINC	F81003-11	1
11	WASHER, 10.2 SPLIT LOCK ZINC	F81055-2	2
12	WASHER, LT15 DRIVE WHEEL ZINC-PLATED	086286-1	1
13	PLATE, RA80 MOTOREDUCER SUPPORT	099425-1	1
14	LINK, SBPL 10104 PIVOTAL	097700	1
15	BOLT, M8x25-8.8-B HEX HEAD FULL THREAD ZINC	F81002-5	8
16	WASHER, 8.2 SPLIT LOCK ZINC	F81054-4	8
17	WASHER, 8.4 FLAT ZINC	F81054-1	8
18	BOLT, M10x35-8.8 HEX HEAD FULL THREAD ZINC	F81003-17	2

REPLACEMENT PARTS

Feed Chain Drive & Tensioner

1

19	WASHER, 10.5 FLAT ZINC	F81055-1	2	
20	NUT, M10-8-B HEX NYLON ZINC LOCK	F81033-1	1	
21	PAD, FEED TRACK PLASTIC (MEDIUM)	099376	2	
22	BOLT, M6x16 8.8 HEX HEAD FULL THREAD ZINC	F81001-15	12	
23	BOLT, M16x160-8.8 HEX HEAD ZINC	F81006-20	2	
24	WASHER, 17 FLAT ZINC	F81058-1	4	
25	NUT, M16-8 HEX NYLON ZINC LOCK	F81036-2	2	
26	CLAMP, RSGU 1.10/12 W1 METAL & RUBBER	086861	3	
27	WASHER, 5.3 FLAT ZINC	F81052-1	3	
28	SCREW, H M5x10 8.8 CROSS RECESSED PAN HEAD ZINC	F81000-13	3	
29	BOLT, 20/M16X90 12.9 ISO7379 SHOULDER	F81006-30 ¹	1	
30	PLATE, GUIDE ROLLER COVER ZINC-PLATED	099441-1 ¹	1	
31	WASHER, 21 FLAT ZINC	F81059-2 ¹	2	
32	ROLLER, R-80-80 (ZABI)	099429 ¹	1	
33	MOUNT WELDMENT, HR CHAIN DRIVE	099378-1	1	
34	WASHER, 6.5 SPECIAL FLAT ZINC	F81053-11	12	
35	BUSHING, 6.2X10X5 ZINC-PLATED SPACER	503674-1	8	

¹ The quantities of rollers and their mounting hardware are: HR1/2 - 12 pcs, HR3/4 - 20 pcs, HR5/6 - 28 pcs.

1 REPLACEMENT PARTS

Idle Roller Table, SLPIRT

1.29 Idle Roller Table, SLPIRT

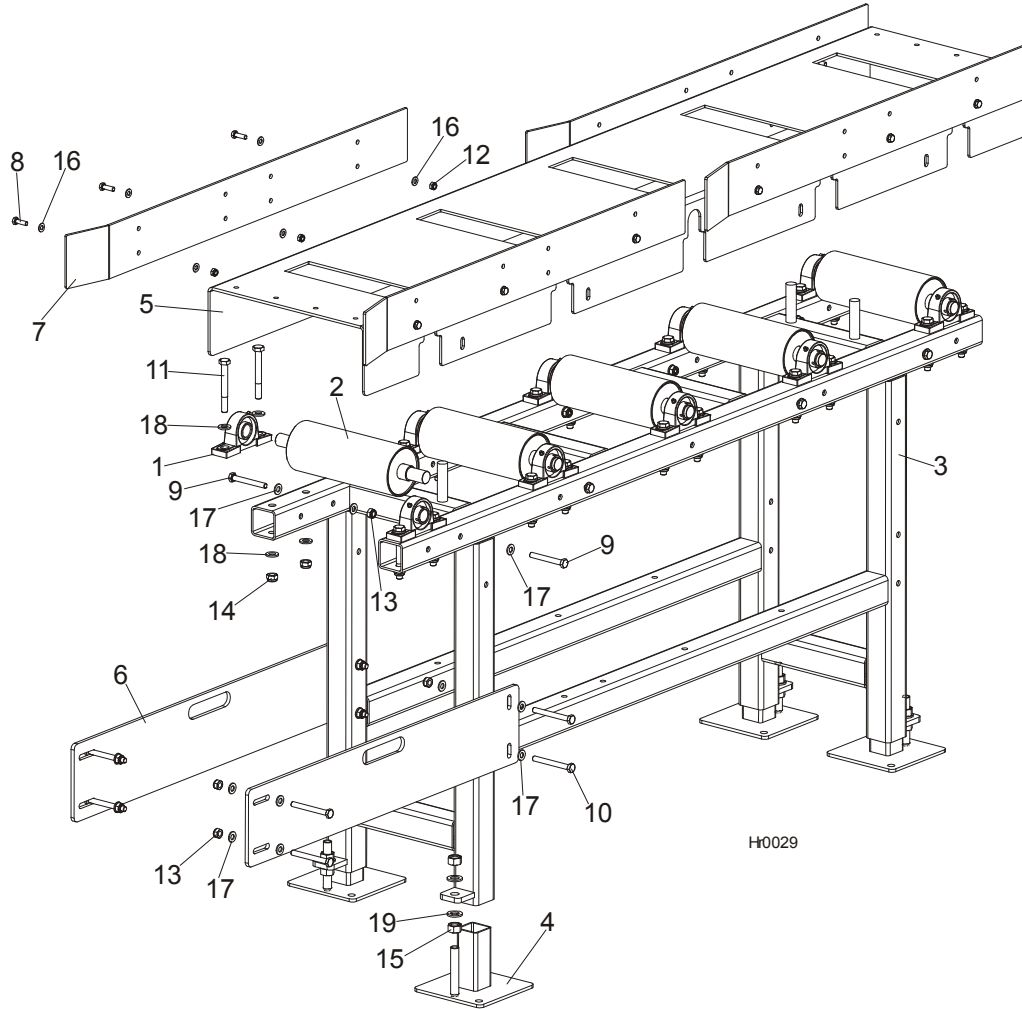

REF.	DESCRIPTION (◆ Indicates Parts Available In Assemblies Only)	PART #	QTY.
	HR IDLE ROLLER TABLE	SLPIRT	1
	IDLE RETURN TABLE - COMPLETE	099659	1
1	BEARING, UCP 205 CX W/HOUSING	088468	10
2	ROLLER, SVS FEED	098140-1	5
3	FRAME, SVS INFEED & OUTFEED TABLE	099168-1	1
4	FOOT ASSEMBLY, TABLE LEG	099281-1	4
5	PLATE, RETURN TABLE TOP	099686-1	1
6	PLATE, RETURN TABLE CONNECTION	099687-1	2
7	PLATE, GUIDE	099688-1	4
8	BOLT, M8x25-8.8-B HEX HEAD FULL THREAD ZINC	F81002-5	12
9	BOLT, M10x80-8.8 HEX HEAD ZINC	F81003-50	9
10	BOLT, M10x90-8.8-B HEX HEAD ZINC	F81003-66	8
11	BOLT, M12x100-8.8 HEX HEAD ZINC	F81004-3	20

REPLACEMENT PARTS

Idle Roller Table, SLPIRT

1

12	NUT, M8-8-B HEX NYLON ZINC LOCK	F81032-2	12	
13	NUT, M10-8-B HEX NYLON ZINC LOCK	F81033-1	17	
14	NUT, M12-8 HEX NYLON ZINC LOCK	F81034-2	20	
15	NUT, M16-5.8 HEX ZINC	F81036-1	8	
16	WASHER, 8.4 FLAT ZINC	F81054-1	23	
17	WASHER, 10.5 FLAT ZINC	F81055-1	34	
18	WASHER, 13 FLAT ZINC	F81056-1	40	
19	WASHER, 17 FLAT ZINC	F81058-1	8	

1 REPLACEMENT PARTS

Cross Roller Table, SLPCRT

1.30 Cross Roller Table, SLPCRT

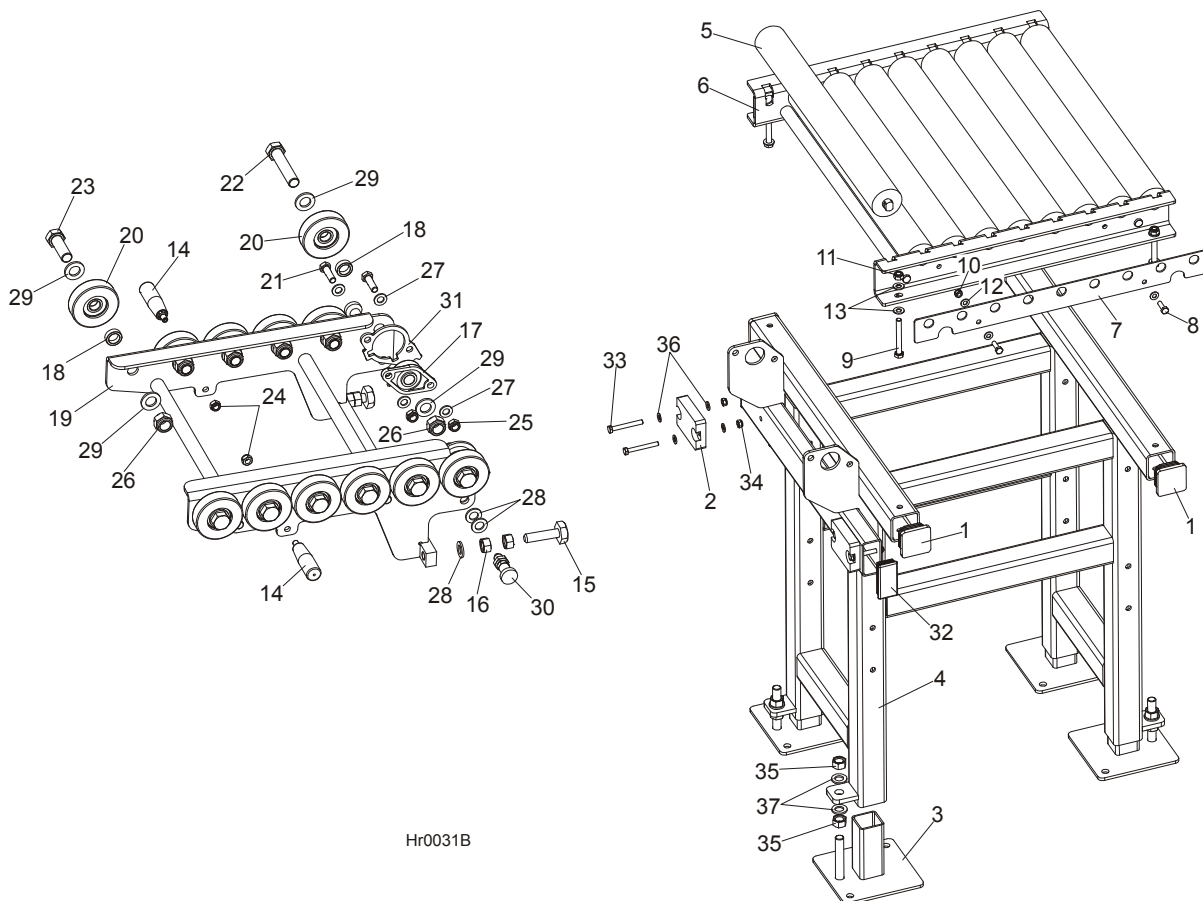

REF.	DESCRIPTION (◆ Indicates Parts Available In Assemblies Only)	PART #	QTY.
	HR CROSS ROLLER TABLE	SLPCRT	1
	COMPLETE CROSS RETURN TABLE	099648	1
1	CAP, 1540 DIA. OUTRIGGER LEG	089710	4
2	BUMPER, GRENE 70 3201 0010. SHR RUBBER	094969	2
3	FOOT ASSEMBLY, TABLE LEG	099281-1	4
4	FRAME WELDMENT, CROSS RETURN TABLE	099652-1	1
	TOP, 63.5X600 CROSS RETURN TABLE - COMPLETE	099656	1
5	ROLLER, 63.5/20X600/608/626 s=14 (EE15)	089044-1	9
6	BRACKET, 63.5X600 ROLLER MOUNTING	099649-1	1
7	PLATE, 63.5/20X600 ROLLER CLAMP	099650-1	2
8	BOLT, M8x25-8.8-B HEX HEAD FULL THREAD ZINC	F81002-5	4
9	BOLT, M10x80-8.8 HEX HEAD ZINC	F81003-50	4
10	NUT, M8-8-B HEX NYLON ZINC LOCK	F81032-2	4
11	NUT, M10-8-B HEX NYLON ZINC LOCK	F81033-1	4
12	WASHER, 8.4 FLAT ZINC	F81054-1	8
13	WASHER, 10.5 FLAT ZINC	F81055-1	8

REPLACEMENT PARTS*Cross Roller Table, SLPCRT***1**

	ARM, OPENED W/RP-90 ROLLERS - COMPLETE	099679	1	
14	KNOB, PLASTIC CRANK HANDLE	086338	2	
	M16 BOLTS +2 NUTS	093710	2	
15	NUT, M16-5-B HEX	F81036-5	1	
16	BOLT, M16 BED RAIL ADJUSTMENT	086809	2	
17	BEARING, UCFL204 (COMPLEX) W/HOUSING	500060	2	
18	BUSHING, 21X30X10 ZINC-PLATED SPACER	099351-1	12	
19	ARM WELDMENT, OPENED	099680-1	1	
20	ROLLER, RP-90. 6304 POLYURETHANE	099689	12	
21	BOLT, M12x40-8.8 HEX HEAD ZINC	F81004-1	4	
22	BOLT, M20X100-8.8 HEX HEAD ZINC	F81007-6	2	
23	BOLT, M20X60-8.8 HEX HEAD ZINC	F81007-7	10	
24	NUT, M10-8-B HEX NYLON ZINC LOCK	F81033-1	2	
25	NUT, M12-8 HEX NYLON ZINC LOCK	F81034-2	4	
26	NUT, M20-8-A HEX NYLON ZINC LOCK	F81037-2	12	
27	WASHER, 13 FLAT ZINC	F81056-1	8	
28	WASHER, 17 FLAT ZINC	F81058-1	8	
29	WASHER, 21 FLAT ZINC	F81059-2	24	
30	PIN, 45308DNW DETENT	089939	2	
31	PLATE, OPENED ARM LOCK	503336-1	2	
32	CAP, 80x40 TUBE	099692	2	
33	BOLT, M8x65 8.8 HEX HEAD FULL THREAD ZINC	F81002-9	4	
34	NUT, M8-8-B HEX NYLON ZINC LOCK	F81032-2	4	
35	NUT, M16-5.8 HEX ZINC	F81036-1	8	
36	WASHER, 8.4 FLAT ZINC	F81054-1	8	
37	WASHER, 17 FLAT ZINC	F81058-1	8	

1 REPLACEMENT PARTS

Hydraulic Blade Tensioner Assembly

1.31 Hydraulic Blade Tensioner Assembly

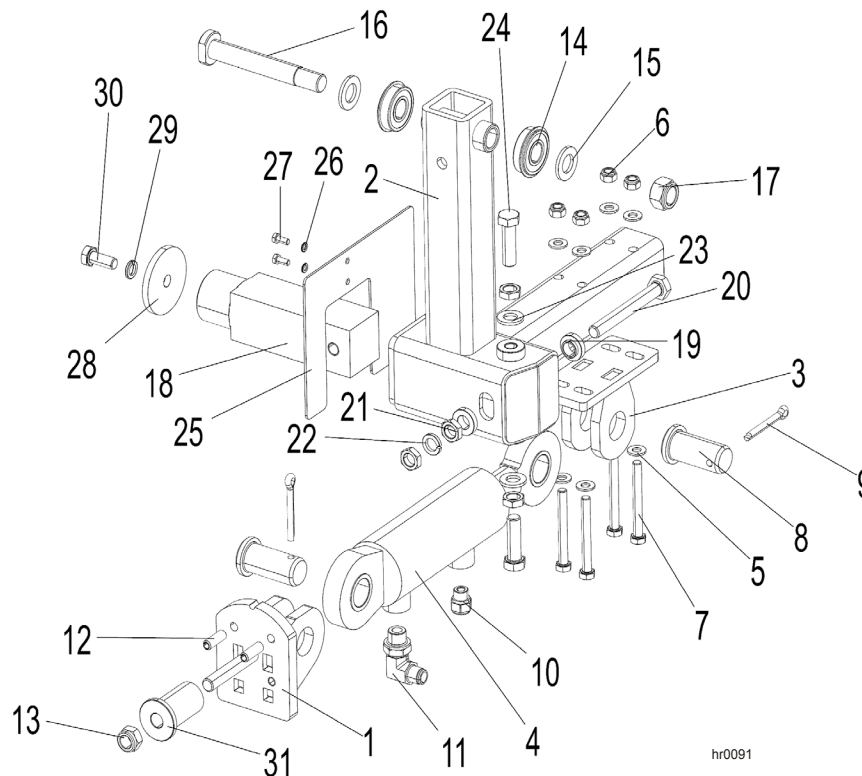

REF.	DESCRIPTION (◆ Indicates Parts Available In Assemblies Only)	PART #	QTY.
	HR/SHS HYDRAULIC BLADE TENSIONER - COMPLETE	506750	1
1	BRACKET, PISTON CYLINDER MOUNT	506751-1	1
2	ARM WELDMENT, TVS IDLE BLADE WHEEL (RIGHT-SIDE SAW HEAD)	504817-1	1
3	BRACKET, PISTON CYLINDER UPPER MOUNT	504819-1	1
4	CYLINDER, SJ2F-16-50/28/70 PISTON	504812	1
5	WASHER, 8.4 FLAT ZINC	F81054-1	8
6	NUT, M8 8 HEX NYLON ZINC LOCK	F81032-2	4
7	BOLT, M8x70-8.8 HEX HEAD ZINC	F81002-71	4
8	PIN	504824-1	2
9	PIN, S-Zn-6.3x45 COTTER	F81045-2	2
10	SILENCER, TYPE 2901-14-17	090794	1
11	FITTING, 90° - 3/8 BSP - 9/16 JIC ELBOW	096335	1
12	PIN, 8x26 ZINC ROLL	F81046-4	2
13	NUT, M12 8 HEX NYLON ZINC LOCK	F81034-2	1
14	BEARING, 6203-2RS NR. W/SNAP RING	086395	2
15	WASHER, 17 SPLIT LOCK ZINC	F81058-1	2
16	BOLT, ARM BEARING MOUNT	086404	1
17	NUT, M16-8 HEX NYLON ZINC LOCK	F81036-2	1
18	SHAFT, IDLE-SIDE BLADE WHEEL	088474	1
19	WASHER, FLANGED ZINC-PLATED	086769-1	2
20	BOLT, M12x1.25x100-8.8 HEX HEAD FULL THREAD ZINC	F81004-41	1

REPLACEMENT PARTS

Hydraulic Blade Tensioner Assembly

1

21	NUT, M12X1.25-8 ZINC THIN	F81034-5	4	
22	WASHER, Z12.2 SPLIT LOCK ZINC	F81056-2	1	
23	WASHER, 13 FLAT ZINC	F81056-1	2	
24	BOLT, M12x1.25x40-8.8 HEX HEAD FULL THREAD ZINC	F81004-42	2	
25	GUARD, IDLE BLADE WHEEL ARM	088442-1	1	
26	WASHER, 5.1 SPLIT LOCK	F81052-2	2	
27	BOLT, M5X12 5.8 HEX HEAD FULL THREAD ZINC	F81000-5	2	
28	WASHER, IDLE BLADE WHEEL RETAINING	088957-1	1	
29	WASHER, Z 10.2 SPLIT LOCK ZINC	F81055-2	1	
30	BOLT, M10X25 8.8 HEX HEAD FULL THREAD	F81003-31	1	
31	BUSHING, 28.5 TO 13 ZINC-PLATED REDUCER	508708-1	1	

1 REPLACEMENT PARTS

Hydraulic Blade Tensioner

1.32 Hydraulic Blade Tensioner

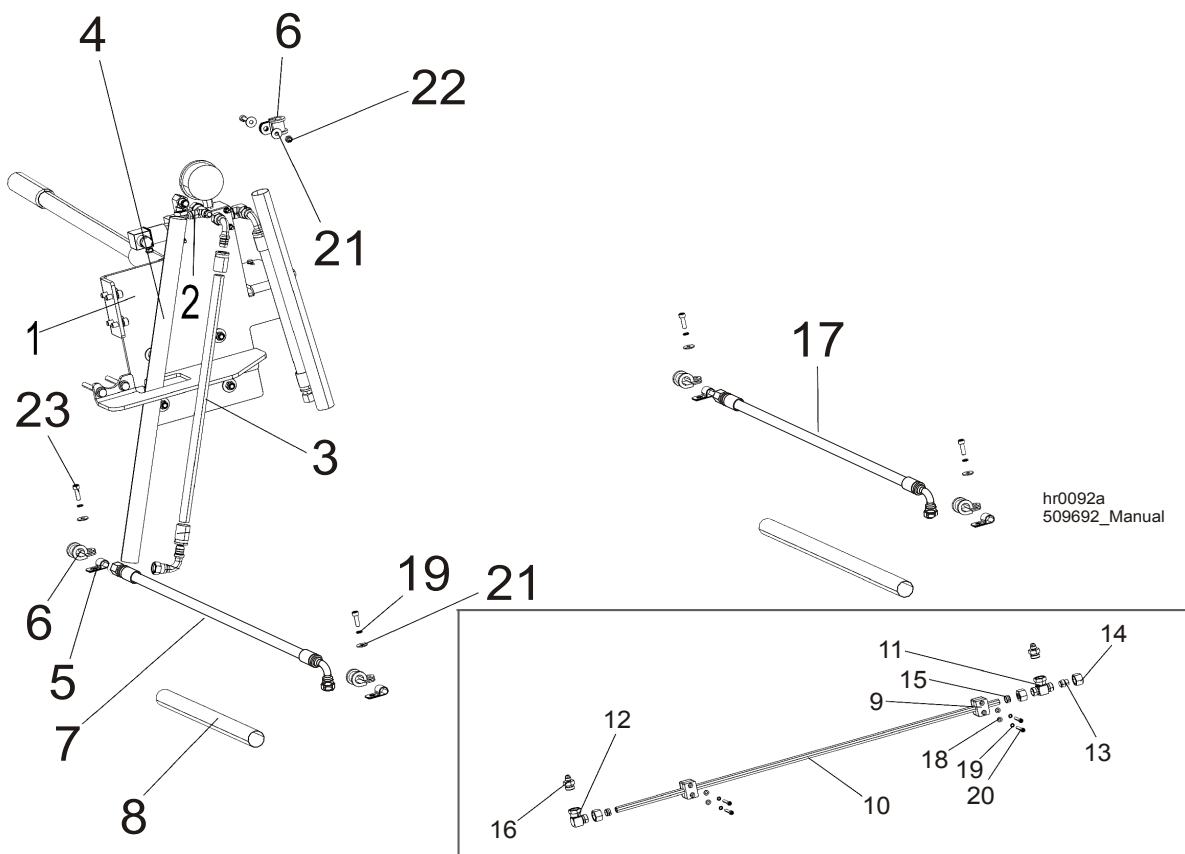

REF.	DESCRIPTION (◆ Indicates Parts Available In Assemblies Only)	PART #	QTY.
	HYDRAULIC BLADE TENSIONER FOR HR700-1 - COMPLETE	511863	1
	HYDRAULIC PUMP ASSEMBLY, SHS/HR500/HR700	506733	1
	HOSE, PHD 2T3/8x0.43 90W9/16UNF-90W9/16UNF HYDRAULIC	506737	1
	GUARD, OBLIQUE HOSE	508714	1
	HYDRAULIC BLADE TENSIONER FOR HR700-2 - COMPLETE	511864	1
1	HYDRAULIC PUMP ASSEMBLY, SHS/HR500/HR700	506733 ¹	1
2	FITTING, BBA UNF 9/16" TEE W/NUT	509687	1
3	HOSE, PHD 2T3/8x0.43 90W9/16UNF-90W9/16UNF HYDRAULIC	506737	1
4	GUARD, OBLIQUE HOSE	508714	2
5	CLAMP, 1/2" EMT COATED	P07584	4
6	CLAMP, RSGU 1.15/20 METAL & RUBBER	509701	6
7	HOSE, PHD 2T3/8x2.85 90W9/16UNF-W9/16UNF HYDRAULIC	509718	1
8	GUARD, VERTICAL HOSE	508713	1
9	BLOCK, DN15 APP-L-15 PIPE BRACKET	509720	2
10	PIPE, L=1050	509699	1
11	FITTING, XEVT 15 L 22x1.5 TEE W/NUT	509688	1
12	FITTING, XEWW 15 L 22x1.5 ELBOW W/NUT	509689	1

REPLACEMENT PARTS

Hydraulic Blade Tensioner

1

13	CAP, DKL 22x1.5 15 L.	509698	1	
14	NUT, M 15 L M22x1.5	509690	3	
15	SLEEVE, DPR 15 L. PIPE CLINCH	509697	2	
16	FITTING, 9/16"-18 UNF - M22x1.5 ZINC-PLATED REDUCER	510446-1	2	
17	HOSE, PHD 2T3/8x2.85 90W9/16UNF-W9/16UNF HYDRAULIC	509719	1	
18	WASHER, 6.4 FLAT ZINC	F81053-1	4	
19	WASHER, Z 6.1 SPLIT LOCK	F81053-3	8	
20	SCREW, M6x35 8.8 HEX SOCKET HEAD CAP ZINC	F81001-23	4	
21	WASHER, 6.5 SPECIAL FLAT ZINC	F81053-11	8	
22	NUT, M6-8-B HEX NYLON ZINC LOCK	F81031-2	2	
23	SCREW, M6x20 8.8 HEX SOCKET HEAD CAP ZINC	F81001-22	6	
	HYDRAULIC BLADE TENSIONER FOR HR700-3 - COMPLETE	511865	1	
	HYDRAULIC BLADE TENSIONER FOR HR500-1 - COMPLETE	509691	1	
	HYDRAULIC BLADE TENSIONER FOR HR500-2 - COMPLETE	509692	1	
	HYDRAULIC BLADE TENSIONER FOR HR700-4 - COMPLETE	511866	1	
	HYDRAULIC BLADE TENSIONER FOR HR500-2 - COMPLETE	509692	2	
	HYDRAULIC BLADE TENSIONER FOR HR700-5 - COMPLETE	511867	1	
	HYDRAULIC BLADE TENSIONER FOR HR500-1 - COMPLETE	509691	1	
	HYDRAULIC BLADE TENSIONER FOR HR500-2 - COMPLETE	509692	2	
	HYDRAULIC BLADE TENSIONER FOR HR700-6 - COMPLETE	511868	1	
	HYDRAULIC BLADE TENSIONER FOR HR500-2 - COMPLETE	509692	3	

¹ [See Section 1.33](#)

1 REPLACEMENT PARTS

Hydraulic Pump Assembly

1.33 Hydraulic Pump Assembly

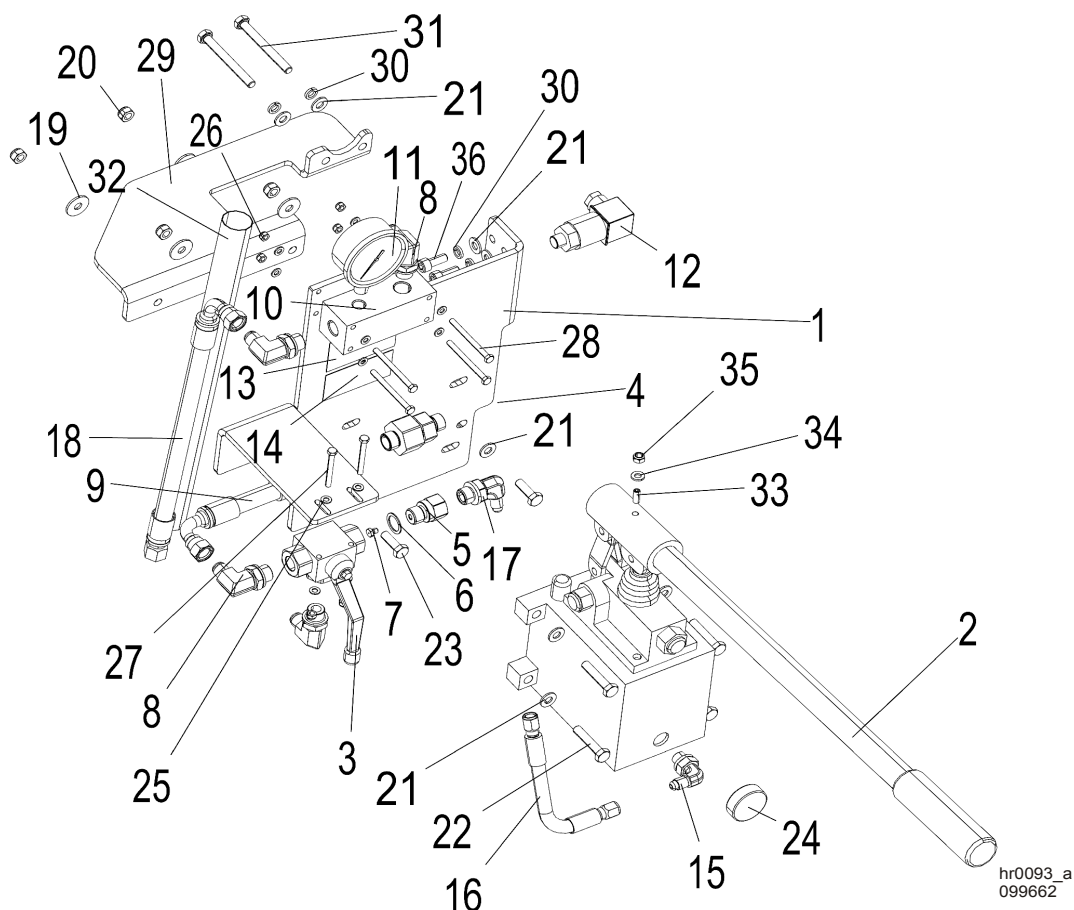

REF.	DESCRIPTION (◆ Indicates Parts Available In Assemblies Only)	PART #	QTY.
	HYDRAULIC PUMP ASSEMBLY, SHS/HR500/HR700	506733	1
1	PLATE, MOUNTING	506734-1	1
2	PUMP, PMS12/TNK1 W/ONE-LITER TANK	092789	1
3	VALVE, RSAP3 VO2L G3/8" 3-WAY BALL	504803	1
4	VALVE, RHV12LREDA3C (HVR NW10MLED) CHECK	094559	1
	FITTING, G 3/8 W/NOZZLE	096849	1
5	FITTING, G3/8 ZINC-PLATED SPECIAL	096850-1	1
6	WASHER, 16 COPPER	F81058-3	1
7	NOZZLE, D092-O 1MM DIA. PROPANE&BUTANE	091007	1
8	FITTING, 90\$ - 3/8 BSP - 9/16 JIC ELBOW	096335	4
9	HYDRAULIC HOSE, 3/8' W/DKJ 90 DN10 9/16 UNF/DKOL DN10 M18x1.5 END FITTINGS	504831	1
10	BLOCK, MOUNTING	504829-1	1
11	GAUGE, 200 BAR (3000PSI) PRESSURE	505176	1
12	SWITCH, F4-T-1-M3-16 BAR PRESSURE	504830	1
13	DECAL, PRESSURE VALUE SETTING	505348	1
14	DECAL, TVS BLADE TENSIONER HANDLE POSITION	505346	1

REPLACEMENT PARTS*Hydraulic Pump Assembly***1**

15	FITTING, CA-204410-3 (W90HROKO4HJ) G1/4-JIC37.7/16-20 ELBOW	094562	1	
16	HOSE, 1/4 (0.19m) HYDRAULIC	505174	1	
17	FITTING, CA-204411-3 (W90HROKO6HJ04) G3/8-JIC37.7/16-20 ELBOW	094563	1	
18	HOSE, PHD 2T3/8x0.27 90W9/16UNF-W9/16UNF HYDRAULIC	506736	1	
19	WASHER, ISO 7093-1-8-200 HV-A2E	F81054-11	4	
20	NUT, M8 8 HEX NYLON ZINC LOCK	F81032-2	6	
21	WASHER, 8.4 FLAT ZINC	F81054-1	14	
22	BOLT, M8X40-8.8 HEX HEAD FULL THREAD ZINC	F81002-15	4	
23	BOLT, M8x25-8.8-B HEX HEAD FULL THREAD ZINC	F81002-5	2	
24	MAGNET, MW 38x12/N38 NEODYMIUM	500022	1	
25	WASHER, 5.3 FLAT ZINC	F81052-1	12	
26	NUT, M5-8-FE/ZN5 DIN985	F81030-2	6	
27	BOLT, M5x45 DIN933-A2-70 STAINLESS STEEL	F81000-22	2	
28	BOLT, M5X60 8.8 HEX HEAD ZINC	F81000-36	4	
29	BRACKET, SUPPORT	506732-1	1	
30	WASHER, 8.2 SPLIT LOCK ZINC	F81054-4	6	
31	BOLT, M8x75-8.8 HEX HEAD ZINC	F81002-91	2	
32	GUARD, VERTICAL HOSE	508713	1	
33	LATCH, GN 615.3-M6-KN BALL THREADED	096874	1	
34	WASHER, 6.4 FLAT ZINC	F81053-1	1	
35	NUT, M6-8-B HEX NYLON ZINC LOCK	F81031-2	1	
36	SCREW, M8x20-8.8 HEX SOCKET HEAD CAP ZINC	F81002-30	4	

1 REPLACEMENT PARTS

Control Box

1.34 Control Box

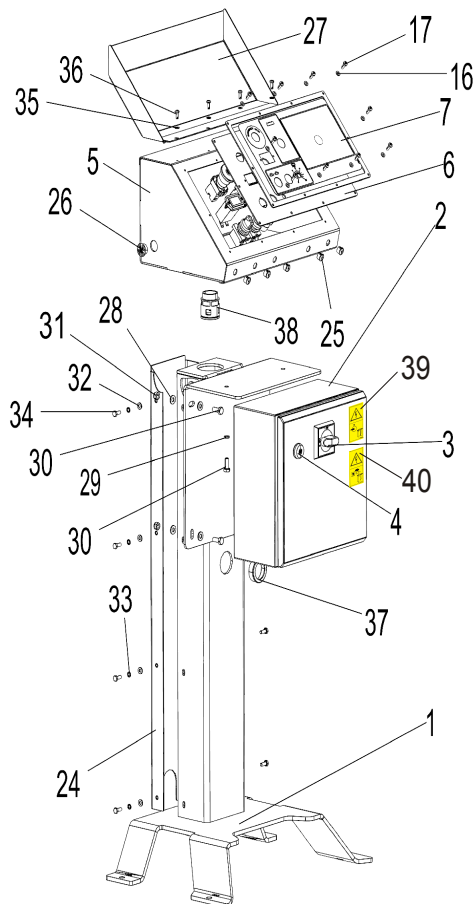
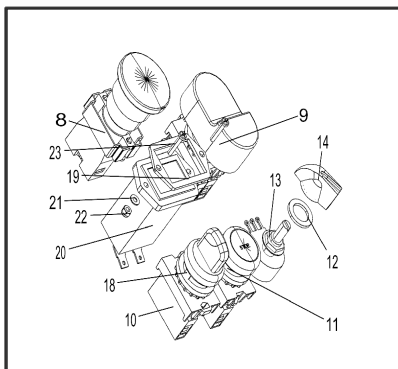

Hr0094

REF.	DESCRIPTION (◆ Indicates Parts Available In Assemblies Only)	PART #	QTY.
	BOX, HR500/700 CONTROL - COMPLETE	507170	1
1	PEDESTAL, CONTROL BOX	505555-1	1
	BOX, TVS ELECTRIC	507269	1
2	BOX WELDMENT, SAREL S83002/300x300x150	092627	1
3	KNOB, OHB S2A1 AB SWITCH	502312-1	1
4	LIGHT, 1SFA619402L5415 WHITE CONTROL	509129	1
5	BOX WELDMENT, TVS CONTROL	510061-1	1
	PANEL ASSEMBLY, HR500/700 CONTROL BOX FRONT	511804	1
6	PANEL, HR500/700 CONTROL BOX FRONT	511803-1	1
7	DECAL, HR500/700 CONTROL BOX	510765	1
8	BUTTON, EMERGENCY STOP	086556	1
9	SWITCH, 24V ILLUMINATED MOELLER START/STOP	090452	1
10	SWITCH, 3-POSITION MOELLER GREEN	091359	1
11	SWITCH, M22 RED PUSHBUTTON	090926	1
12	WASHER, 1/2X3/4X1/16 NYLON	P05251-1	1
13	POTENTIOMETER, 5K 53C35K	504389	1
14	KNOB, SPEED CONTROL	P06257	1

REPLACEMENT PARTS

Control Box

1

15	GASKET, CONTROL BOX	097132	1	
16	WASHER, 5.3 FLAT ZINC	F81052-1	10	
17	BOLT, #10-24X1/2 PH PAN HEAD, TYPE 23	F05015-17	10	
18	ADAPTOR, M22-XC-Y CODING	092687	2	
19	GASKET, HOUR METER	093346	1	
20	METER, (HOBBS-HONEYWELL) HOUR	093166	1	
21	WASHER, 3.2 FLAT ZINC	F81050-2	2	
22	NUT, M3-6 HEX NYLON ZINC LOCK	F81028-2	2	
23	SCREW, M3x16 5.8-B CROSS RECESSED PAN HEAD ZINC	F81028-3	2	
24	PLATE, WM1000 REAR CONTROL BOX PEDESTAL	504499-1	1	
25	CAP, HEYMAN DP-812 12.7 HOLE	086773	5	
26	CAP, SR1086 22.2 HOLE	093544	2	
27	COVER, CONTROL BOX - COMPLETE	097135-1	1	
28	WASHER, 8.4 FLAT ZINC	F81054-1	10	
29	WASHER, 8.2 SPLIT LOCK ZINC	F81054-4	2	
30	BOLT, M8X20 8.8 HEX HEAD FULL THREAD ZINC	F81002-4	6	
31	NUT, M8 8 HEX NYLON ZINC LOCK	F81032-2	4	
32	WASHER, 6.4 FLAT ZINC	F81053-1	8	
33	WASHER, Z 6.1 SPLIT LOCK	F81053-3	8	
34	BOLT, M6x16-8.8 HEX HEAD FULL THREAD ZINC	F81001-15	8	
35	WASHER, 5.3 FLAT ZINC	F81052-1	4	
36	BOLT, #10-24X1/2 PH PAN HEAD, TYPE 23	F05015-17	4	
37	BUSH, MOSS 44.5mm 465901 SNAP-FIT	R80670-3	1	
38	GLAND, KLINK-GP29 RILL 29 CONDUIT	086576	1	
39	DECAL, HAZARDOUS VOLTAGE INSIDE THE ELECTRIC BOX (PICTOGRAM)	096316	1	
40	DECAL, REMOVE THE PLUG BEFORE OPENING THE ELECTRIC BOX (PICTOGRAM)	096319	1	

1 REPLACEMENT PARTS

Up/Down Screw Drive Assembly, HR700 (Option)

1.35 Up/Down Screw Drive Assembly, HR700 (Option)

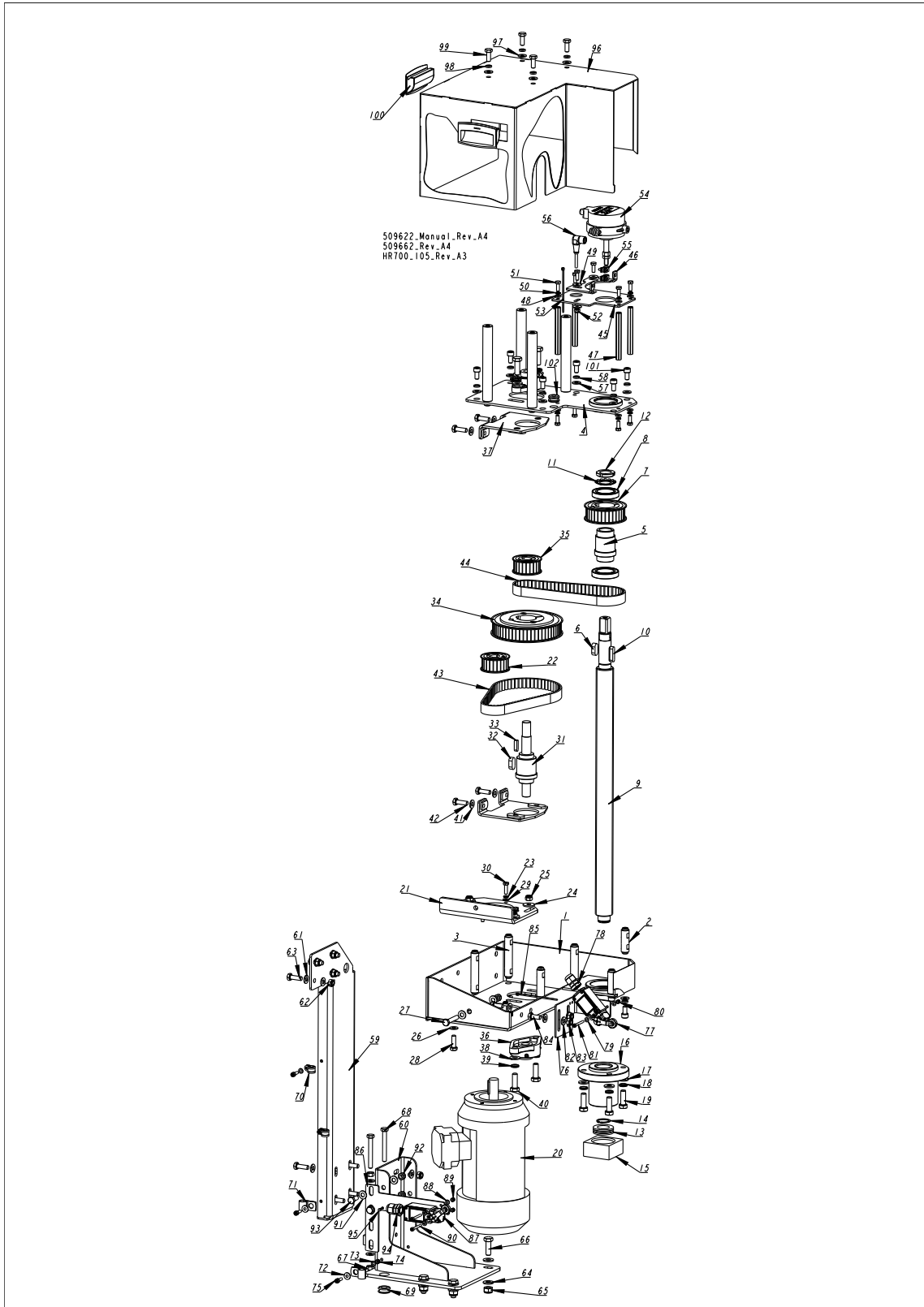

REPLACEMENT PARTS

Up/Down Screw Drive Assembly, HR700 (Option)

1

REF.	DESCRIPTION (◆ Indicates Parts Available In Assemblies Only)	PART #	QTY.
	MULTISETWORKS, HR700-1	511869	1/0/0/0/0/0
	MULTISETWORKS, HR700-2	511870	0/1/0/0/0/0
	MULTISETWORKS, HR700-3	511871	0/0/1/0/0/0
	MULTISETWORKS, HR700-4	511872	0/0/0/1/0/0
	MULTISETWORKS, HR700-5	511873	0/0/0/0/1/0
	MULTISETWORKS, HR700-6	511874	0/0/0/0/0/1
	SCREEN, HMISTU855 TOUCH	508978	1/1/1/1/1/1
	DRIVE ASSEMBLY, HR700 UP/DOWN SCREW	507350	1/2/3/4/5/6

REF.	DESCRIPTION (◆ Indicates Parts Available In Assemblies Only)	PART #	QTY.
	DRIVE ASSEMBLY, HR700 UP/DOWN SCREW	507350	1
1	MOUNT WELDMENT, HR700/SHS UP/DOWN DRIVE	507375-1	1
2	BUSHING, SHORT ZINC-PLATED SPACER	507371-1	2
3	BUSHING, LONG ZINC-PLATED SPACER	507370-1	4
4	PLATE, TOP	507368-1	1
	SCREW, HR700/SHS UP/DOWN ACME - COMPLETE	508527	1
5	BUSHING, ACME SCREW ZINC-PLATED	507353-1	1
6	KEY, A12X8X25 PARALLEL	508528	1
7	WHEEL, TL-32-8M-20/16F/40 (T35413+T31080) TOOTHED	507352	1
8	BEARING, 61907 2RS (CX),6907 2RS (MGK) BALL	507354	2
9	SCREW, TR36X3 ACME ZINC-PLATED	506779-1	1
10	KEY, A8X7X32 PARALLEL	088564	1
11	WASHER, MB05 LOCK	508649	1
12	NUT, KM05 (M25X1.5) LOCK	508648	1
13	BEARING, 51105 THRUST	088033	1
14	RING, 25Z OUTSIDE RETAINING	F81090-22	1
15	BLOCK, ACME SCREW REST ZINC-PLATED	093265-1	1
16	NUT, TR36X3 ACME SCREW	506780	1
17	WASHER, 10.5 FLAT ZINC	F81055-1	4
18	WASHER, Z 10.2 SPLIT LOCK ZINC	F81055-2	4
19	BOLT, M10X30 5.8 HEX HEAD FULL THREAD ZINC	F81003-2	4
	MOTOR, UP/DOWN SCREW DRIVE - COMPLETE	507362	1
20	MOTOR, SKH-80X-D2 8D IMB14/2-80J6, 0.55KW 690 INDUCTION	507356	1
21	PLATE, MOTOR MOUNTING	507363-1	1
22	WHEEL, TL22-8M-20/16F/19 (T35403+T31011) TOOTHED	507351	1
23	WASHER, Z 6.1 SPLIT LOCK ZINC	F81053-3	5
24	WASHER, ISO 7093-1-8-200 HV-A2E.	F81054-11	4
25	NUT, M8 8 HEX NYLON ZINC LOCK	F81032-2	5
26	WASHER, 8.4 FLAT ZINC	F81054-1	6
27	BOLT, M8X45-8.8 HEX HEAD FULL THREAD ZINC	F81002-14	1
28	BOLT, M8X25-8.8-B HEX HEAD FULL THREAD ZINC	F81002-5	4
29	WASHER, 6.4 FLAT ZINC	F81053-1	4
30	BOLT, M6X20 8.8 HEX HEAD FULL THREAD ZINC	F81001-2	4
	SHAFT ASSEMBLY, INTERMEDIATE	508530	1

1

REPLACEMENT PARTS

Up/Down Screw Drive Assembly, HR700 (Option)

REF.	DESCRIPTION (◆ Indicates Parts Available In Assemblies Only)	PART #	QTY.	
31	SHAFT, ZINC-PLATED INTERMEDIATE	508529-1	1	
32	KEY, A12X8X25	508528	1	
33	KEY, 6X6X23	089191	1	
34	WHEEL, TL-56-8M-20/40 (T35428+T31110) TOOTHED	507349	1	
35	WHEEL, TL22-8M-20/16F/19 (T35403+T31011) TOOTHED	507351	1	
36	BEARING, UCFL 203 (CX) W/HOUSING	507347	2	
37	PLATE, TOOTHED BELT TENSION	507366-1	2	
38	WASHER, 10.5 FLAT ZINC	F81055-1	4	
39	WASHER, Z 10.2 SPLIT LOCK ZINC	F81055-2	4	
40	BOLT, M10X30 5.8 HEX HEAD FULL THREAD ZINC	F81003-2	4	
41	WASHER, 8.4 FLAT ZINC	F81054-1	4	
42	BOLT, M8X25-8.8-B HEX HEAD FULL THREAD ZINC	F81002-5	4	
43	BELT, POWER GRIP GT3 600 8MGT 20 (F06391 ULMER) TOOTHED	507360	1	
44	BELT, POWER GRIP GT3 560 8MGT 20 (F06390 ULMER) TOOTHED	507361	1	
	ENCODER ASSEMBLY, HR-L.	508531	1	
45	PLATE, ENCODER MOUNT	507373-1	1	
46	BRACKET, ENCODER	507372-1	1	
47	SPACER, M6X100- BN3319 (BOSSARD)	F81031-10	4	
48	WASHER, 6.4 FLAT ZINC	F81053-1	8	
49	WASHER, 6.5 SPECIAL FLAT ZINC	F81053-11	4	
50	WASHER, Z 6.1 SPLIT LOCK ZINC	F81053-3	8	
51	BOLT, M6X16-8.8 HEX HEAD FULL THREAD ZINC	F81001-15	10	
52	NUT, M6-8-B HEX NYLON ZINC LOCK	F81031-2	2	
53	WRAP, TK 9/3 TIE	F81082-4	1	
54	ENCODER, 48 IMP./TURN 12V DC INCREMENTAL	510285	1	
55	CLAMP, OM 0911	F81080-11	2	
56	CABLE, 5M LIMIT SWITCH	087652	1	
57	WASHER, 8.4 FLAT ZINC	F81054-1	12	
58	WASHER, 8.2 SPLIT LOCK ZINC	F81054-4	12	
	BRACKET, HR700 UP/DOWN DRIVE SUPPORT - COMPLETE	507376	1	
59	PLATE, UPPER	507377-1	1	
60	PLATE WELDMENT, LOWER	507378-1	1	
61	WASHER, 8.4 FLAT ZINC	F81054-1	20	
62	NUT, M8 8 HEX NYLON ZINC LOCK	F81032-2	8	
63	BOLT, M8X25-8.8-B HEX HEAD FULL THREAD ZINC	F81002-5	8	
64	WASHER, 10.5 FLAT ZINC	F81055-1	8	
65	NUT, M10-8-B HEX NYLON ZINC LOCK	F81033-1	4	
66	BOLT, M10X30 5.8 HEX HEAD FULL THREAD ZINC	F81003-2	4	
67	NUT, M8-8-B HEX ZINC	F81032-1	4	
68	BOLT, M8X65 8.8 HEX HEAD FULL THREAD ZINC	F81002-9	2	
69	GROMMET, 20/13 RUBBER	086188	1	
70	CLAMP, RSGU 1.10/12 W1 METAL & RUBBER	086861	2	
71	CLAMP, 1/2" EMT COATED	P07584	2	
72	WASHER, 5.5 SPECIAL FLAT ZINC	F81052-3	2	
73	WASHER, 5.3 FLAT ZINC	F81052-1	6	

REPLACEMENT PARTS*Up/Down Screw Drive Assembly, HR700 (Option)***1**

REF.	DESCRIPTION (◆ Indicates Parts Available In Assemblies Only)	PART #	QTY.	
74	NUT, M5-8-FE/ZN5 DIN985	F81030-2	4	
75	SCREW, M5X16-8.8 HEX SOCKET HEAD CAP ZINC	F81000-25	4	
	UPPER LIMIT SWITCH - COMPLETE	508517	1	
76	BRACKET, UPPER LIMIT SWITCH MOUNT	508518-1	1	
77	SWITCH, GLCB01A1B LIMIT	100931	1	
78	GLAND, DP9/H CABLE	F81096-2	1	
79	WASHER, 4.3 FLAT ZINC	F81051-2	4	
80	NUT, M4-8 HEX NYLON ZINC LOCK	F81029-1	2	
81	SCREW, M4X35 8.8 HEX SOCKET HEAD CAP ZINC	F81011-34	2	
82	WASHER, 8.4 FLAT ZINC	F81054-1	4	
83	NUT, M8 8 HEX NYLON ZINC LOCK	F81032-2	2	
84	BOLT, M8X20 5.8 HEX HEAD FULL THREAD ZINC	F81002-1	2	
85	WRAP, TK 9/3 TIE	F81082-4	1	
	LOWER LIMIT SWITCH - COMPLETE	508519	1	
86	PLATE, LOWER LIMIT SWITCH MOUNT	508520-1	1	
87	SWITCH, GLCB01A1B LIMIT	100931	1	
88	WASHER, 4.3 FLAT ZINC	F81051-2	4	
89	NUT, M4-8 HEX NYLON ZINC LOCK	F81029-1	2	
90	SCREW, M4X35 8.8 HEX SOCKET HEAD CAP ZINC	F81011-34	2	
91	WASHER, 8.4 FLAT ZINC	F81054-1	4	
92	NUT, M8 8 HEX NYLON ZINC LOCK	F81032-2	2	
93	BOLT, M8X20 5.8 HEX HEAD FULL THREAD ZINC	F81002-1	2	
94	GLAND, DP9/H CABLE	F81096-2	1	
95	WRAP, TK 9/3 TIE	F81082-4	1	
	GUARD, HR700/SHS UP/DOWN DRIVE - COMPLETE	508522	1	
96	GUARD, UP/DOWN DRIVE	508523-1	1	
97	WASHER, 8.4 FLAT ZINC	F81054-1	4	
98	WASHER, 8.2 SPLIT LOCK ZINC	F81054-4	4	
99	BOLT, M8X20 8.8 HEX HEAD FULL THREAD ZINC	F81002-4	4	
100	HANDLE, EPR.90-PF-C1(261051-C1) SNAP-IN FLUSH PULL	100012	2	
101	SCREW, M8X16-8.8 HEX SOCKET HEAD CAP ZINC	F81002-39	12	
102	GROMMET, 3/8" ID RUBBER	025248	1	

1 REPLACEMENT PARTS

Ground Cable

1.36 Ground Cable

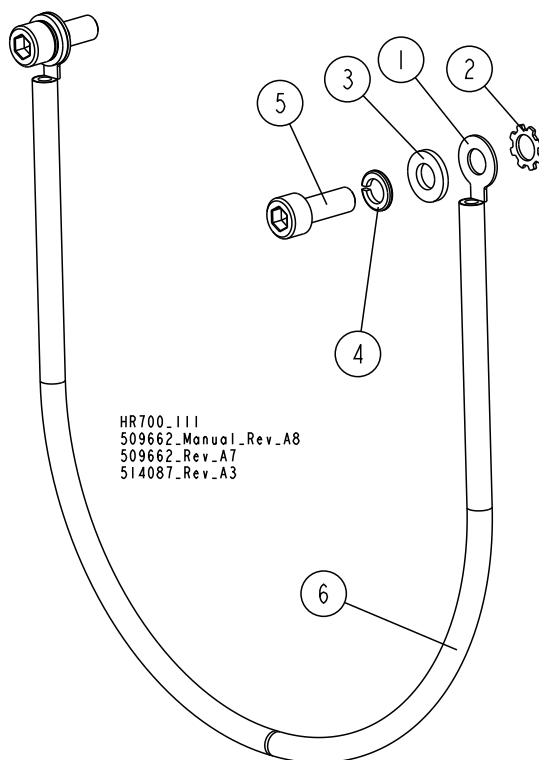

REF.	DESCRIPTION (◆ Indicates Parts Available In Assemblies Only)	PART #	QTY.
	CABLE, COMPLETE GROUND	514087	1
1	TERMINAL, 1/4 14-16GA RING NI LOOSE	F81065-1	2
2	WASHER, 6.4 FE/ZN5 SERRATED LOCK EXTERNAL TEETH	F81053-2	2
3	WASHER, 6.4 FLAT ZINC	F81053-1	2
4	WASHER, Z 6.1 SPLIT LOCK	F81053-3	2
5	SCREW, M6X16 8.8 HEX SOCKET HEAD CAP ZINC	F81001-21	2
6	CABLE, GROUND	R80587-3_400	1