

**Twin Vertical Saw
Spiky Chain
TVS - SC
Parts Manual**

**TVSE11S - SC
TVSE15S - SC**

**rev.B3.00
rev.B3.00**



Safety is our #1 concern! Read and understand all safety information and instructions before operating, setting up or maintaining this machine.

October 2010

Form #1018

Table of Contents

Section-Page

SECTION 1	GENERAL INFORMATION	1-1
1.1	How To Use The Parts List	1-1
1.2	Sample Assembly	1-1
SECTION 2	BLADE GUIDE ROLLERS & ARM	2-1
2.1	Blade Guide Assembly, Idle Side.....	2-1
2.2	Blade Guide Assembly, Drive Side.....	2-3
SECTION 3	BLADE WHEELS & TENSIONER	3-1
3.1	Blade Wheel Assembly, Drive Side	3-1
3.2	Blade Wheel Assembly, Idle Side	3-2
3.3	Blade Tensioner Assembly	3-3
3.4	Blade Tensioner Pump Assembly	3-5
SECTION 4	SAW HEAD	4-1
4.1	Middle Throat Screw	4-1
4.2	Water Lube Assembly (LMS)	4-2
4.3	Saw Head Decals	4-4
4.4	Blade Housing Cover	4-5
4.5	Saw Head Width Manual Adjustment Assembly	4-7
4.6	Saw Head Width Automatic Adjustment Assembly (Optional).....	4-9
4.7	Saw Head Width Indicator	4-12
4.8	Saw Head Slide Brackets.....	4-13
4.9	Hold-Down Roller (V-tables).....	4-14
4.10	Saw Head Hold-Down Roller (Spiky Chain Table)	4-16
4.11	Blade Drive Motor.....	4-17
4.12	Saw Head Support Rollers.....	4-18
4.13	Electric Box	4-20
4.14	Control Box	4-21
4.15	Laser Assembly (Optional)	4-23
SECTION 5	TVS-SC INFEED & OUTFEED TABLES	5-1
5.1	Conical Roller Table.....	5-1
5.2	TVSIS2.4 & TVSIS3.6 Infeed Table	5-3
5.3	Hold-Down Roller	5-5
5.4	TVS SC 2.4 & TVSSC 3.6 Outfeed Table	5-7
5.5	Side Front Rollers	5-10
5.6	f 100 Side Spiral Rollers	5-11
5.7	f 130 Side Spiral Rollers	5-12
5.8	Drive Assembly, TVS SC Outfeed Table Side Roller	5-13
5.9	Slab Stop Plates	5-15
5.10	TVS-SC Chain Drive Assembly.....	5-16
5.11	TVS SC 2.4 Table Transport Brackets	5-18
5.12	Outfeed Table Hold-Down Rollers (2.4)	5-19
5.13	Outfeed Table Hold-Down Rollers (2.4E)	5-20
5.14	Outfeed Table Hold-Down Rollers (3.6)	5-21

Table of Contents

Section-Page

5.15	Outfeed Table Hold-Down Rollers (3.6E)	5-22
5.16	Barriers & Side Guards, TVS SC 2.4 (Only CE Version).....	5-23
5.17	Barriers & Side Guards, TVS SC 3.6 (Only CE Version).....	5-25
5.18	Alignment Tool	5-27
5.19	Alignment Tool	5-28
5.20	Laser Assembly (Option)	5-29
SECTION 6 INCLINE LOG DECK		6-1
6.1	Infeed Assembly	6-1
6.2	Additional Grid, Option For TVS Incline Log Deck	6-2
6.3	Limit Switch Assembly	6-3
6.4	Drive Assembly	6-4
6.5	Chain Guards	6-6
6.6	Decals	6-7
SECTION 7 CROSS TRANSFER DECK		7-1
7.1	Front Module & Chains	7-1
7.2	Central Module	7-3
7.3	Rear Module	7-4
7.4	Cross Transfer Deck Drive	7-5
7.5	Leg Kits	7-6
7.6	Slabs Table	7-7
7.7	Decals	7-8

SECTION 1 GENERAL INFORMATION

1.1 How To Use The Parts List

- Use the index above to locate the assembly that contains the part you need.
- Go to the appropriate section and locate the part in the illustration.
- Use the number pointing to the part to locate the correct part number and description in the table.
- Parts shown indented under another part are included with that part.
- Parts marked with a diamond (◆) are only available in the assembly listed above the part.

See the sample table below. Sample Part #A01111 includes part F02222-2 and subassembly A03333. Subassembly A03333 includes part S04444-4 and subassembly K05555. The diamond (◆) indicates that S04444-4 is not available except in subassembly A03333. Subassembly K05555 includes parts M06666 and F07777-77. The diamond (◆) indicates M06666 is not available except in subassembly K05555.

1.2 Sample Assembly				
REF	DESCRIPTION (◆ Indicates Parts Available In Assemblies Only)	PART #	QTY.	
	Sample Assembly, Complete (Includes All Indented Parts Below)	A01111	1	
1	Sample Part	F02222-22	1	
	Sample Subassembly (Includes All Indented Parts Below)	A03333	1	
2	Sample Part (◆ Indicates Part Is Only Available With A03333)	S04444-4	1	◆
	Sample Subassembly (Includes All Indented Parts Below)	K05555	1	
3	Sample Part (◆ Indicates Part Is Only Available With K05555)	M06666	2	◆
4	Sample Part	F07777-77	1	

To Order Parts:

- From Europe call our European Headquarters and Manufacturing Facility in Kolo, Poland at **+48-63-2626000**. From the continental U.S., call our toll-free Parts hotline at **1-800-525-8100**. Have your customer number, vehicle identification number, and part numbers ready when you call. From other international locations, contact the Wood-Mizer distributor in your area for parts.

Office Hours:

Country	Monday - Friday	Saturday	Sunday
Poland	7-15	Closed	Closed
US	8 a.m.- 5 a.m.	8 a.m.- 12 p.m.	Closed



CAUTION! It is strongly recommended that only original spare parts be used.

SECTION 2 BLADE GUIDE ROLLERS & ARM

2.1 Blade Guide Assembly, Idle Side

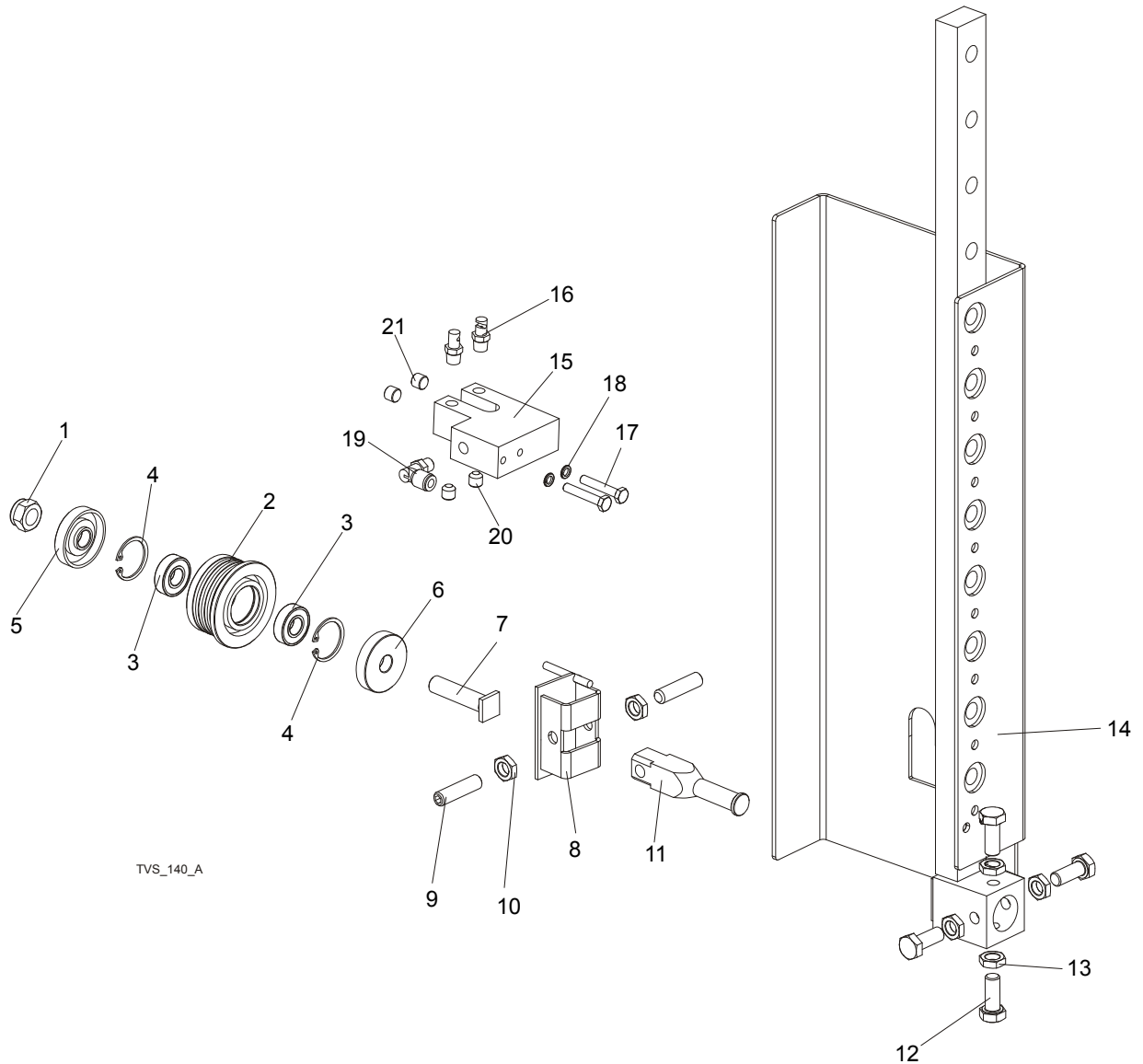

REF	DESCRIPTION (◆ Indicates Parts Available In Assemblies Only)	PART #	QTY.	
	ROLLER, TVS BLADE GUIDE COMPLETE	500562	1	
	ROLLER, TVS BLADE GUIDE	500561	1	
1	NUT, M12-8 HEX NYLON ZINC LOCK	F81034-2	1	
2	ROLLER, TVS BLADE GUIDE WIDE	500560	1	◆
3	BEARING, 6001 2RSR FAG	087893	2	
4	RING, W28 INSIDE RETAINING	F81090-9	1	
5	RING, ZINC-PLATED SPACER (FOR EXTEND.ROLL)	087891-1	1	
6	RING, ZINC-PLATED SPACER (FOR EXTEND.ROLL)	087892-1	1	

7	SHAFT, BLADE GUIDE ROLLER ZINC-PLATED	087762-1	1	
8	BRACKET WELDMENT, BLADE GUIDE PAINTED	500563-1	1	
9	SCREW, M10X1X40 DIN 913 A2-70 SET STAINLESS STEEL	F81015-2	2	
10	NUT, M10X1-04-ST-A2 ISO 8675 THIN	F81033-10	2	
11	SHAFT, BLADE GUIDE MOUNT ZINC-PLATED	088255-1	1	
12	BOLT, M10x1x25 DIN 933	F81003-28	4	
13	NUT, M10x1-04-ST-A2 ISO 8675 THIN	F81033-10	4	
14	ROLLER GUIDE, TVS RIGHT-PTD	508387-1	1	
	ROLLER GUIDE, TVS LEFT- PTD	508390-1	1	
	LUBE SYSTEM, TVS	098583	2	
15	BLOCK, NOZZLE MOUNTING ZINC-PLATED	097943-1	1	
16	NOZZLE, BLADE LUBE SPRAY	033479	2	
17	BOLT, M6x35 8.8 HEX HEAD ZINC	F81001-71	2	
18	WASHER, M6 SPLIT LOCK ZINC	F81053-3	2	
19	Fitting, 1/8MPTx1/4Tube,Elbow,Swivel	P09736	1	
20	Fitting, 1/8 NPT Socket Pipe Plug	P30127	2	
21	PLUG, M10x1 DIN 906 BN40 "BOSSARD"	F81015-3	2	

2.2 Blade Guide Assembly, Drive Side

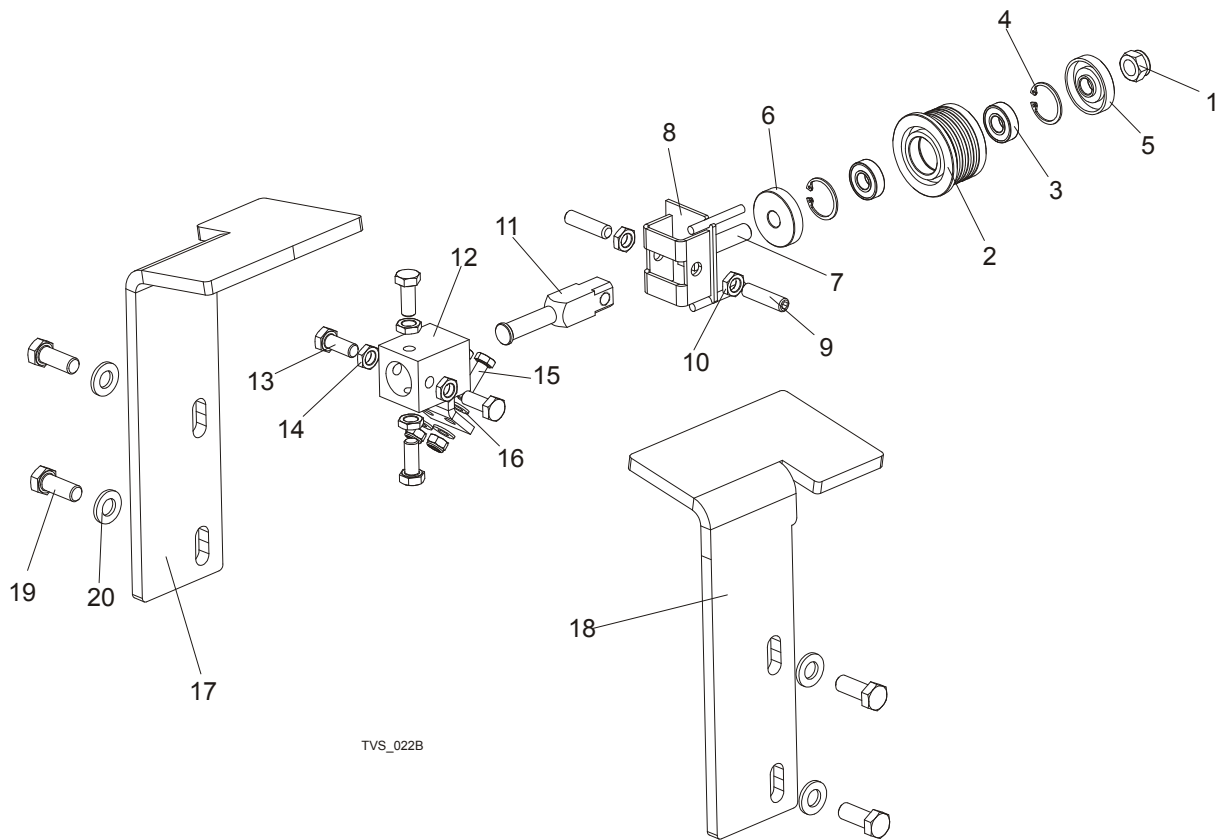

TVS_022B

REF	DESCRIPTION (◆ Indicates Parts Available In Assemblies Only)	PART #	QTY.	
	ROLLER, TVS BLADE GUIDE COMPLETE	500562	1	
	ROLLER, TVS BLADE GUIDE	500561	1	
1	NUT, M12-8 HEX NYLON ZINC LOCK	F81034-2	1	
2	ROLLER, TVS BLADE GUIDE WIDE	500560	1	◆
3	BEARING, 6001 2RSR FAG	087893	2	
4	RING, W28 INSIDE RETAINING	F81090-9	1	
5	RING, ZINC-PLATED SPACER (FOR EXTEND.ROLL)	087891-1	1	
6	RING, ZINC-PLATED SPACER (FOR EXTEND.ROLL)	087892-1	1	
7	SHAFT, BLADE GUIDE ROLLER ZINC-PLATED	087762-1	1	
8	BRACKET WELDMENT, BLADE GUIDE PAINTED	500563-1	1	
9	SCREW, M10X1X40 DIN 913 A2-70 SET STAINLESS STEEL	F81015-2	2	
10	NUT, M10X1-04-ST-A2 ISO 8675 THIN	F81033-10	2	
11	SHAFT, BLADE GUIDE MOUNT ZINC-PLATED	088255-1	1	
12	BLOCK WELDMENT, PAINTED BLADE GUIDE MOUNT	088292-1	3	
13	BOLT, M10X1X25 DIN 933 STAINLESS STEEL	F81003-28	1	
14	NUT, M10x1-04-ST-A2 ISO 8675 THIN	F81033-10	4	
15	BOLT, M8X20MM, HEX HEAD,GR 5.8 ZINC	F81002-4	2	

2**Blade Guide Rollers & Arm***Blade Guide Assembly, Drive Side*

16	WASHER, 8.2 SPLIT LOCK ZINC	F81054-4	2	
17	COVER, DRIVE SIDE ROLLER RIGHT	097660-1	1	
18	COVER, DRIVE SIDE ROLLER LEFT	098435-1	1	
19	BOLT M12x30-8.8 HEX HEAD FULL THREAD ZINC	F81004-22	4	
20	WASHER, M12 FLAT ZINC	F81056-1	4	

SECTION 3 BLADE WHEELS & TENSIONER

3.1 Blade Wheel Assembly, Drive Side

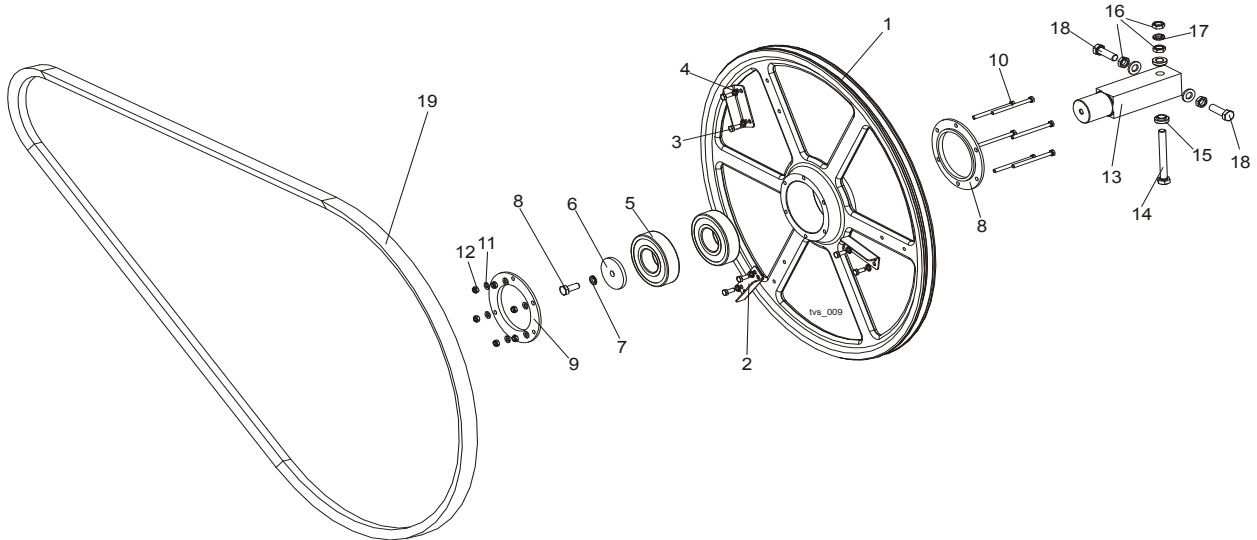

REF	DESCRIPTION (◆ Indicates Parts Available In Assemblies Only)	PART #	QTY.
	DRIVE WHEEL, TVS COMPLETE	096109	1
1	Wheel, Drive-Side Blade Ptd.	096105-1	1
2	Wing, TVS	097808-1	3
3	Bolt, M6 x 16 8.8 Hex Head Full Thread Zinc	F81001-15	6
4	Washer, Z6.1 Split Lock Zinc	F81053-3	6
5	Bearing, 6309 2RSR	096107	2
6	Washer, Idle Blade Wheel Retaining	088957-1	1
7	Washer, 10.2 Split Lock Zinc	F81055-2	1
8	Bolt, M10X25 8.8 Hex Head Full Thread	F81003-31	1
9	Ring, Bearing Mounting	096108-1	2
10	Bolt, M6x80 Hex Head Full Thread Zinc	F81001-61	6
11	Washer, 6.4 Flat Zinc	F81053-1	6
12	Nut, M6-8-B Hex Nylon Zinc Lock	F81031-2	6
13	AXLE, DRIVE WHEEL TVS	096110	1
14	BOLT, M12X1.25X100-8.8 HEX HEAD FULL THREAD ZINC	F81004-41	1
15	SPACER, BLADE GUIDE	086769-1	2
16	NUT, M12X1.25 8.8 HEX ZINC THIN	F81034-5	3
17	WASHER, M12 SPLIT LOCK ZINC	F81056-2	1
18	BOLT, M12X1.25X40 HEX HEAD ZINC	F81004-42	2
19	BELT, 5VX1080	033391	1

3.2 Blade Wheel Assembly, Idle Side

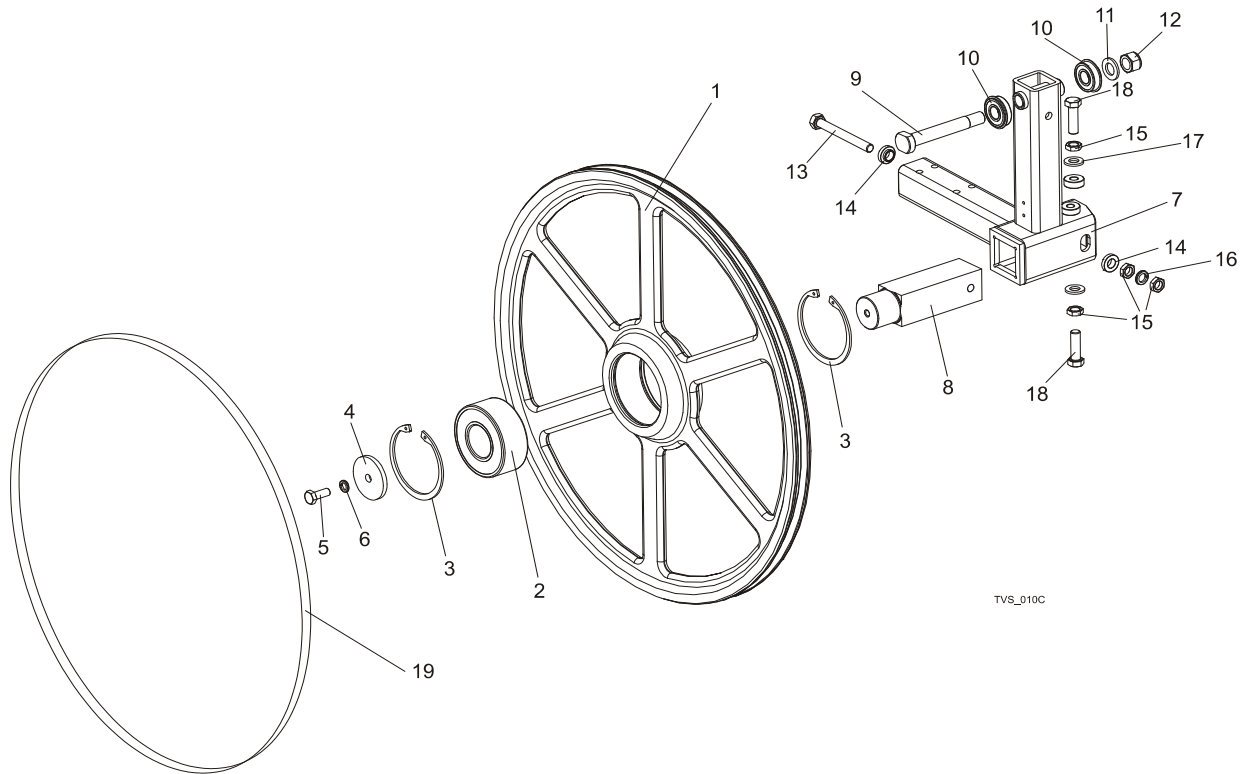

REF	DESCRIPTION (◆ Indicates Parts Available In Assemblies Only)	PART #	QTY.
	WHEEL ASSEMBLY, IDLE SIDE COMPLETE	088764	1
1	Wheel, Idle Side Ptd.	090810-1	1
2	Bearing, 3309B.2RSR.TVH FAG	086428	1
3	Ring, W100 Inside Retaining	F81090-10	2
4	WASHER, BLADE WHEEL RETAINING ZINC-PLATED	088957	1
5	BOLT, M10X25 8.8 HEX HEAD FULL THREAD	F81003-31	1
6	WASHER, 10.2 SPLIT LOCK ZINC	F81055-2	1
7	ARM WELDMENT, TVS IDLE LEFT SIDE BLADE WHEEL	504816-1	1
	ARM WELDMENT, TVS IDLE RIGHT SIDE BLADE WHEEL	504817-1	1
8	SHAFT, IDLE SIDE BLADE WHEEL	088474	1
9	BOLT, ARM BEARING MOUNT	086404	1
10	BEARING, 6203-2RS NR NSK W/SNAP RING	086395	2
11	WASHER, 17 FLAT ZINC	F81058-1	1
12	NUT, M16-8 HEX NYLON ZINC LOCK	F81036-2	1
13	BOLT, M12X1.25X100-8.8 HEX HEAD FULL THREAD ZINC	F81004-41	1
14	WASHER, FLANGED ZINC-PLATED	086769-1	2
15	NUT, M12X1.25 8.8 HEX THIN ZINC	F81034-5	4
16	WASHER, Z12.2 SPLIT LOCK ZINC	F81056-2	1
17	WASHER, 13 FLAT ZINC	F81056-1	2
18	BOLT, M12X1.25X40-8.8 HEX HEAD FULL THREAD ZINC	F81004-42	2
19	BELT, B72.5	017922	1

3.3 Blade Tensioner Assembly

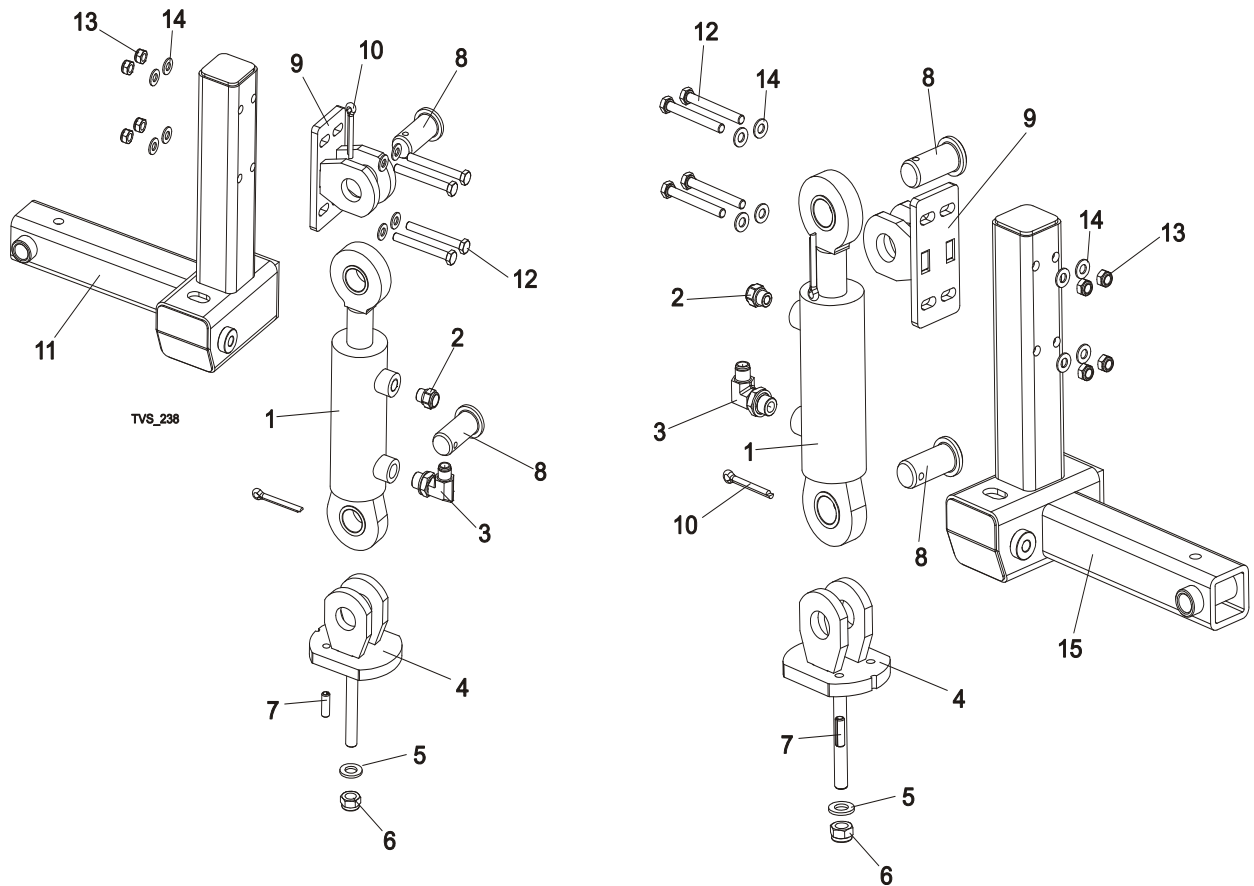

REF	DESCRIPTION (◆ Indicates Parts Available In Assemblies Only)	PART #	QTY.
	HYDRAULIC BLADE TENSIONER, RIGHT SIDE	504826	1
1	CYLINDER, SJ2F-16-50/28/70 HYDRAULIC	504812	1
2	BREATHER, TYPE 2901-14-17	090794	1
3	FITTING, 3/8" BSP-9/16" JIC ELBOW	096335	1
4	BRACKET, HYDRAULIC CYLINDER LOWER MOUNTING	504822-1	1
5	WASHER, M12 FLAT ZINC	F81056-1	1
6	NUT, M12-8 ,HEX NYLON ZINC LOCK	F81034-2	1
7	PIN, 8X26 ROLL ZINC	F81046-4	1
8	PIN, ZINC-PLATED	504824-1	4
9	BRACKET, HYDRAULIC CYLINDER UPPER MOUNTING	504819-1	2
10	PIN, S-ZN 6,3X45 COTTER	F81045-2	4
11	ARM WELDMENT, TVS IDLE RIGHT SIDE BLADE WHEEL	504817-1	1
12	BOLT, M8X70 8.8 HEX HEAD ZINC	F81002-71	8
13	NUT, M8-8-B HEX NYLON ZINC LOCK	F81032-2	8
14	WASHER, 8.4 FLAT ZINC	F81054-1	16
	HYDRAULIC BLADE TENSIONER, LEFT SIDE	504815	1
1	CYLINDER, SJ2F-16-50/28/70 HYDRAULIC	504812	1
2	BREATHER, TYPE 2901-14-17	090794	1
3	FITTING, 3/8" BSP-9/16" JIC ELBOW	096335	1

4	BRACKET, HYDRAULIC CYLINDER LOWER MOUNTING	504822-1	1	
5	WASHER, M12 FLAT ZINC	F81056-1	1	
6	NUT, M12-8 HEX NYLON ZINC LOCK	F81034-2	1	
7	PIN, 8X26 ROLL ZINC	F81046-4	1	
8	PIN, ZINC-PLATED	504824-1	4	
9	BRACKET, HYDRAULIC CYLINDER UPPER MOUNTING	504819-1	2	
10	PIN, S-ZN 6,3X45 CONNER	F81045-2	4	
11	USED IN 504826 ASSEMBLY			
12	BOLT, M8X70 8.8 HEX HEAD ZINC	F81002-71	8	
13	NUT, M8-8-B HEX NYLON ZINC LOCK	F81032-2	8	
14	WASHER, 8.4 FLAT ZINC	F81054-1	16	
15	ARM WELDMENT, TVS IDLE LEFT SIDE BLADE WHEEL	504816-1	1	

3.4 Blade Tensioner Pump Assembly

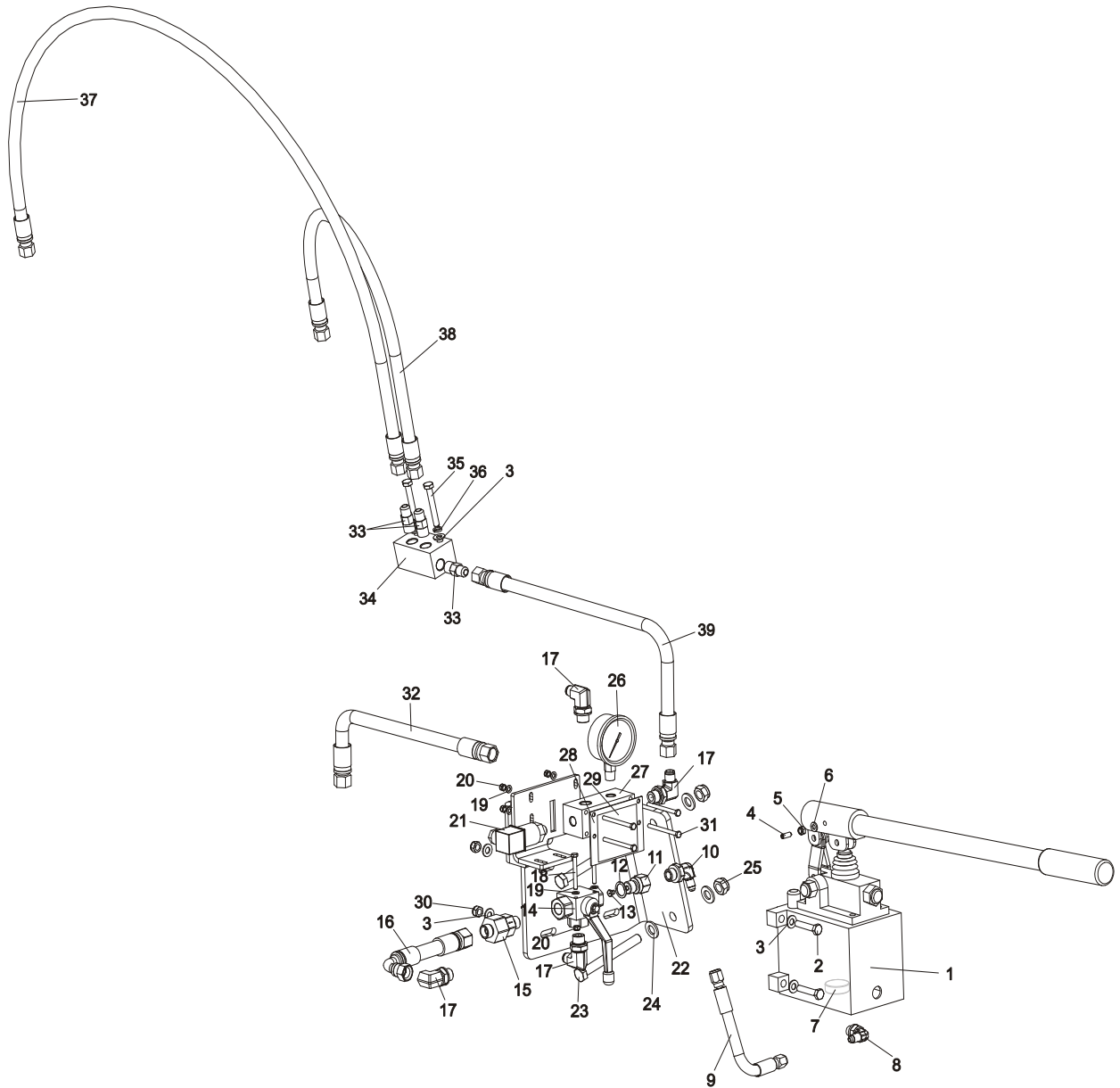

REF	DESCRIPTION (◆ Indicates Parts Available In Assemblies Only)	PART #	QTY.
	BLADE TENSIONER PUMP ASSEMBLY	504825	1
1	PUMP, PMS12/TNK1 W/1-LITRE TANK	092789	1
2	BOLT, M8x40-8.8 HEX HEAD FULL THREAD ZINC	F81002-15	4
3	WASHER, 8.4 FLAT ZINC	F81054-1	10
4	PLUNGER, GN615.3-M6-K BALL THREADED	096874	1
5	NUT, M6-8-B HEX NYLON ZINC LOCK	F81031-2	1
6	WASHER, 6.4 FLAT ZINC	F81053-1	1
7	MAGNET, MW.38x12/N38 NEODYMIUM	500022	1
8	ELBOW, CA-204410-3	094562	1

9	HOSE, 1/4"(0.19M) HYDRAULIC	505174	1	
10	ELBOW, CA-204411-3	094563	1	
	FITTING W/NOZZLE, G 3/8	096849	1	
11	FITTING, G3/8 ZINC-PLATED SPECIAL	096850-1	1	
12	WASHER, 16 COPPER	F81058-3	1	
13	NOZZLE, D092-O 1MM DIA. PROPANE&BUTANE	091007	1	
14	VALVE, RSAP3 VOL2L G3/8" THREE-WAY	504803	1	
15	VALVE, RHV12LREDA3C CHECK	094559	1	
16	HOSE, 3/8" W/9/16 ;M18X1.5 END FITTING	504831	1	
17	FITTING, 3/8" BSP-9/16" JIC ELBOW	096335	4	
18	BOLT, M5X45 DIN933 A2-70 STAINLESS STEEL	F81000-22	2	
19	WASHER, 5.3 FLAT ZINC	F81052-1	6	
20	NUT, M5-8 DIN 985 ZINC-PLATED	F81030-2	6	
21	SWITCH, F4-T-I-M3-16 BAR PRESSURE	504830	1	
22	PLATE WELDMNT, PTD MOUNTING	504836-1	1	
23	BOLT, M12x110-8.8-B HEX HEAD ZINC	F81004-47	2	
24	WASHER, 13 FLAT ZINC	F81056-1	4	
25	NUT, M12-8 HEX NYLON ZINC LOCK	F81034-2	2	
26	GAUGE, 3000PSI OIL PRESSURE	505176	1	
27	BLOCK, ZINC-PLATED MOUNTING	504829-1	1	
28	PLATE, ZINC-PLATED	505310-1	1	
29	DECAL, TVS BLADE TENSIONER HANDLE POSITION	505346	1	
30	NUT, M8-8-B HEX NYLON ZINC LOCK	F81032-2	4	
31	BOLT, M5X60 8.8 HEX HEAD ZINC	F81000-36	4	
32	HOSE, 2T3/8X0.380 W9/16UNF-W9/16UNF HYDRAULIC	504706	1	
33	FITTING, G3/8-9/16-18JIC MANUAL PUMP	091842	3	
34	TEE FITTING, ZINC-PLATED	504828-1	1	
35	BOLT, M8X60-8.8 HEX HEAD ZINC	F81002-54	2	
36	WASHER, 8.2 SPLIT LOCK ZINC	F81054-4	2	
37	HOSE, 3/8" 1.2 M HYDRAULIC	504834	1	
38	HOSE, 3/8:"(0.7M) HYDRAULIC	504833	1	
39	HOSE, 2T3/8X0.540 W9/16UNF-W9/16UNF HYDRAULIC	505173	1	

SECTION 4 SAW HEAD

4.1 Middle Throat Screw

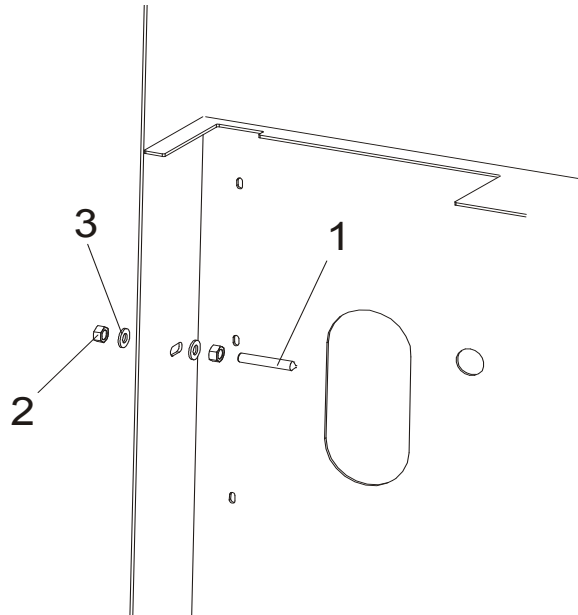

REF	DESCRIPTION (◆ Indicates Parts Available In Assemblies Only)	PART #	QTY.	
1	SCREW, M10X60-45H HEX SOCKET SET CONE POINT ZINC	F81003-87	1	
2	NUT, M10-8-B HEX ZINC	F81033-3	2	
3	WASHER, 10.5 FLAT ZINC	F81055-1	2	

4 Saw Head

Water Lube Assembly (LMS)

4.2 Water Lube Assembly (LMS)

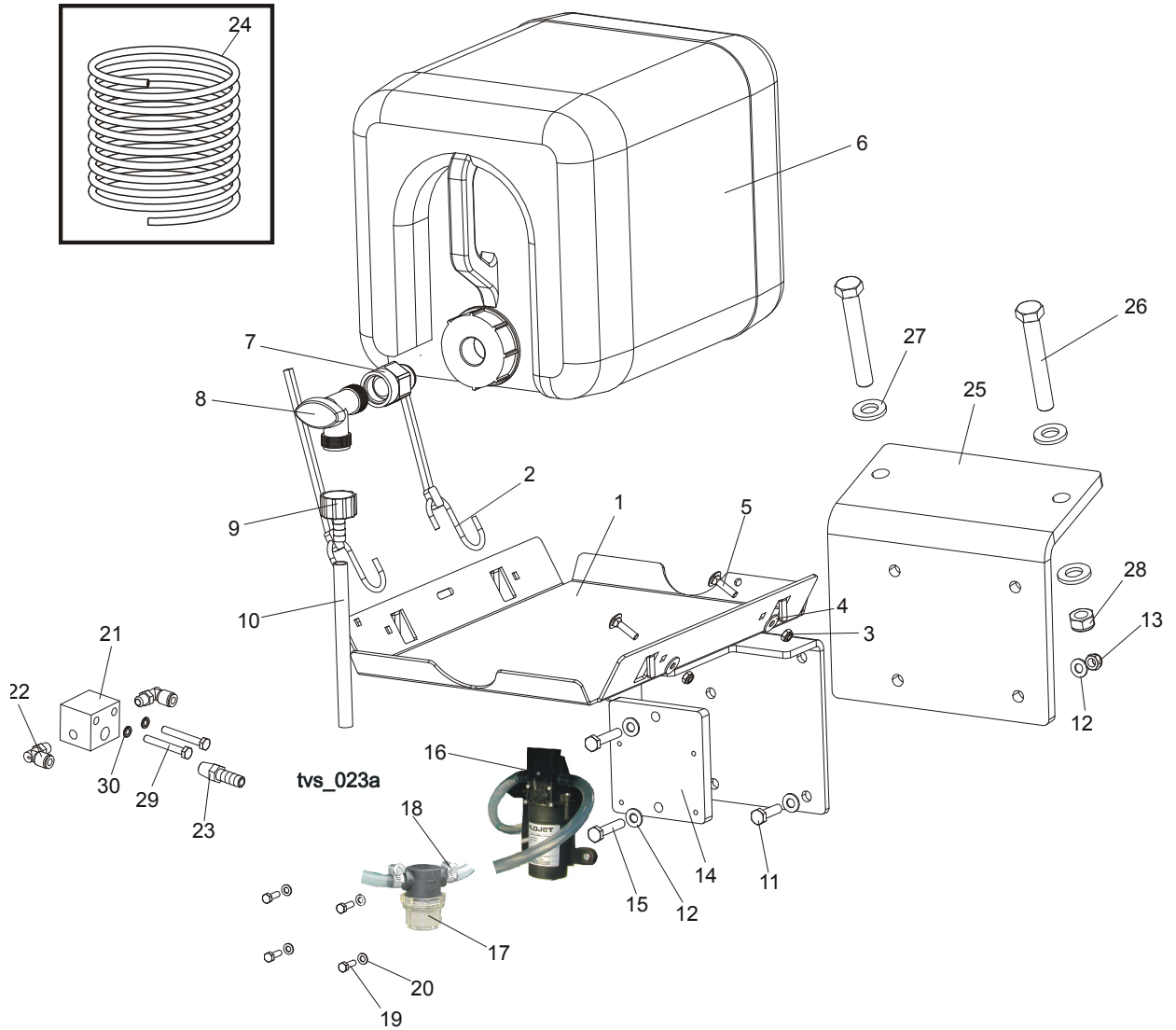

REF	DESCRIPTION (◆ Indicates Parts Available In Assemblies Only)	PART #	QTY.
	BOTTLE KIT, LT20 WATER LUBE	091036	1
1	TRAY WELDMENT, LT20 WATER LUBE	091033-1	1
2	STRAP, 20" RUBBER	P11668	2
3	NUT, M6-8-B HEX NYLON ZINC LOCK	F81031-2	2
4	WASHER, 6.5 ZINC FLAT	F81053-11	2
5	BOLT, M6X25-8.8 CARRIAGE HEAD ZINC	F81001-20	2
6	BOTTLE, 19 L WATER LUBE	014637	1
7	FITTING, 3/4FPT X 3/4MPT	014636	1
8	FITTING, WATER LUBE SHUTOFF VALVE	014100	1
9	FITTING, 5/8" NPT TO 3/8" HOSE BARB	014113	1
10	TUBING, WATER LUBE	R01885	2.1 m
11	BOLT, M8X30-8.8-B-HEX HEAD FULL THREAD ZINC	F81002-7	1
12	WASHER, 8.4 ZINC FLAT	F81054-1	3

13	NUT, M8-8-B HEX NYLON ZINC LOCK	F81032-2	1	
14	BRACKET, LMS PUMP ZINC	098762-1	1	
15	BOLT, 8MM X 1.25 X 40MM HEX HEAD ZINC	F81002-15	2	
16	PUMP ASSEMBLY, PRESSURE LUBE	510763	1	
17	FILTER, PRESSURE LUBE	033447	1	
	SCREEN KIT, MESH FILTER	033441	1	
18	CLAMP, PLASTIC HOSE DIA. 8-12MM	F81080-1	2	
19	BOLT, M5X16-5.8-HEX HEAD FULL THREAD ZINC	F81000-51	4	
20	WASHER, M5, FLAT ZINC	F81052-1	4	
21	FITTING, TEE TVS LMS	099213-1	1	
22	FITTING, 1/8MPTX1/4TUBE ELBOW SWIVEL	P09736	2	
23	FITTING, 1/4NPT-3/8 BARB	014685	1	
24	HOSE, 1/4" OD X 6 1/2'	033456	1	
25	BRACKET, WATER TANK MOUNTING, PTD	096178-1	1	
26	BOLT, M12X80-8.8 HEX HEAD ZINC	F81004-46	2	
27	WASHER, M12 FLAT ZINC	F81056-1	4	
28	NUT, M12 NYLON HEX ZINC LOCK	F81034-1	2	
29	BOLT, M6X45MM HEX HEAD GR5(8.8)F/T ZINC	F81001-6	2	
30	WASHER, M6 SPLIT LOCK ZINC	F81053-3	2	

4.3 Saw Head Decals

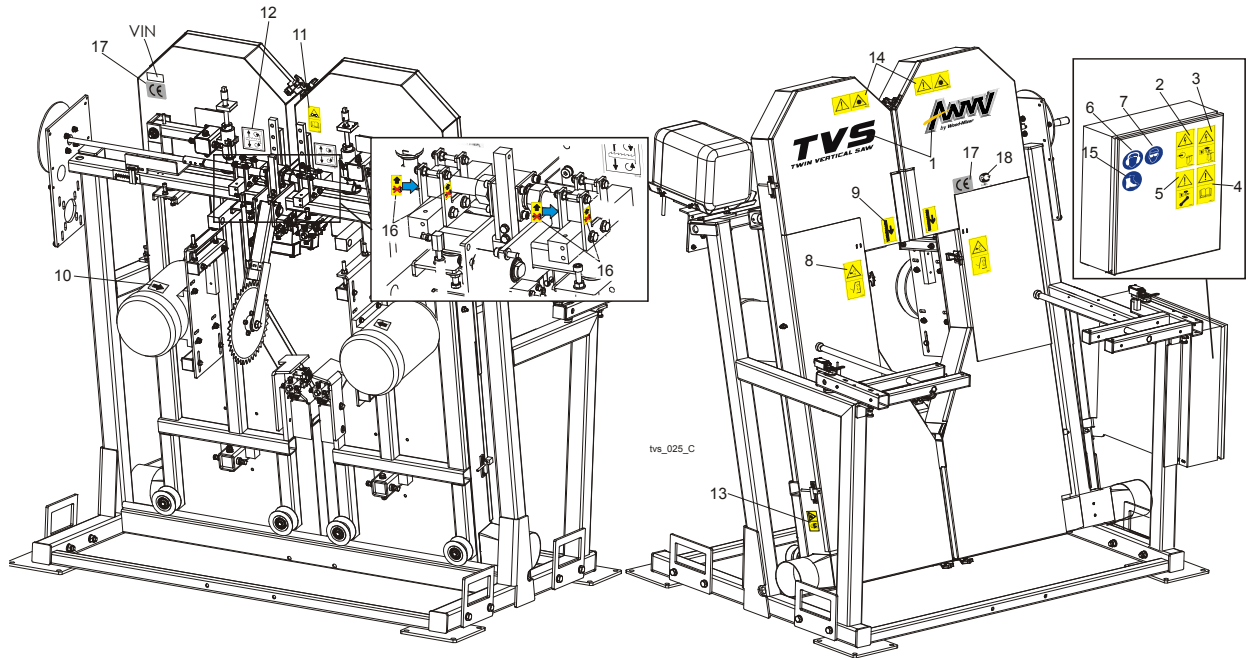

REF	DESCRIPTION (◆ Indicates Parts Available In Assemblies Only)	PART #	QTY.
	DECALS KIT, COMPLETE, TVS, PICTOGRAMS	099479	1
1	DECALS, TVS NAME	099422	1
2	DECAL, HIGH VOLTAGE IN ELECTRIC BOX	096316	1
3	DECAL, DISCONNECT POWER SUPPLY BEFORE OPENING THE BOX	096319	1
4	DECAL, READ THE MANUAL BEFORE OPERATING THE MACHINE	096317	1
5	DECAL, DISCONNECT POWER SUPPLY BEFORE SERVICING	098177	1
6	DECAL, EAR WARNING	S12005G	1
7	DECAL, EYE WARNING	S12004G	1
8	DECAL, CLOSE GUARDS PRIOR TO OPERATING THE MACHINE	099220	2
9	DECAL, BLADE MOVEMENT DIRECTION	096321	2
10	DECAL, MOTOR DIRECTION	S20097	2
11	DECAL, BLADE TENSION - INSTRUCTION, PICTOGRAM	099223	1
12	DECAL, BLADE ALIGNMENT	P11789	2
13	DECAL, SAW DUST PROTECTION, PICTOGRAM	099222	2
14	DECAL, CAUTION - LASER BEAM (OPTIONAL)	099504	2
15	DECAL, USE SAFETY BOOTS (PICTOGRAM)	501465	1
16	DECAL, DON'T ADJUST NUTS, PICTOGRAM	500031	4
	TABLES DECALS, See Section 5.7		
17	DECAL, CE CERTIFIED MACHINE (SMALL)	P85070	1
18	DECAL, GOST CERTIFIED MACHINE	099401	1

4.4 Blade Housing Cover

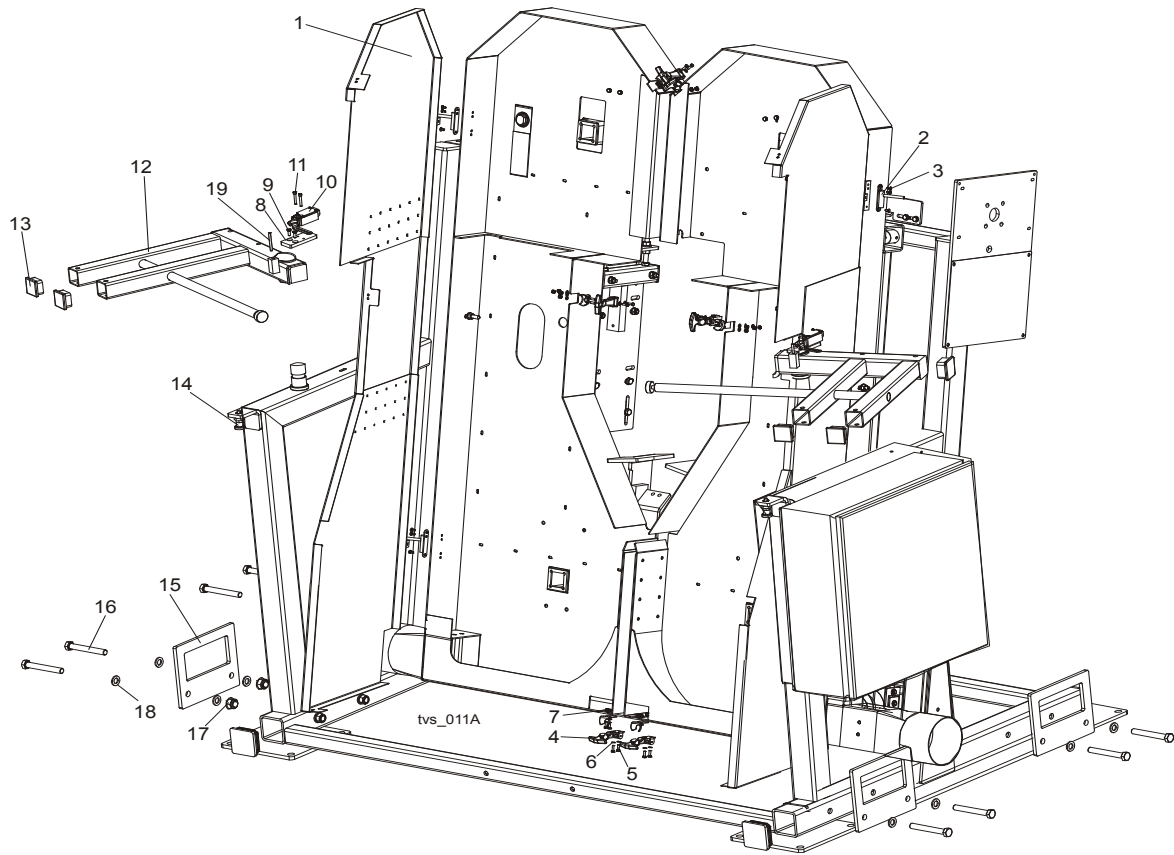

REF	DESCRIPTION (◆ Indicates Parts Available In Assemblies Only)	PART #	QTY.
1	COVER, BLADE HOUSING TVS LEFT WLDMT/PTD	098612-1 (LEFT)	1
	COVER, BLADE HOUSING TVS RIGHT WLDMT/PTD	096117-1 (RIGHT)	1
2	HINGE, COVER	096146	4
3	SCREW, M5X12- 5.8-B SLOTTED COUNTERSUNK ZINC	F81000-15	8
4	LATCH, FLEXIBLE DRAW	014829	6
5	BOLT, M5X16-5.8-HEX HEAD FULL THREAD ZINC	F81000-51	12
6	WASHER, M5, FLAT ZINC	F81052-1	24
7	NUT, M5-8- DIN 985 ZINC	F81030-2	12
8	FLAT BAR, LIMIT SWITCH MOUNTING ZINC	098760-1	2
9	SCREW, M6X16 HEX SOCKET HEAD CAP	F81001-21	4
10	SWITCH, GSCA 01S1 LIMIT	088407	2
11	BOLT, M5X35 8.8 HEX SOCKET HEAD CAP ZINC	F81000-73	4
12	ARM, CONTROL BOX TVS MOUNTING LEFT WLDMT/PTD	098611-1	2
	ARM, CONTROL BOX TVS MOUNTING RIGHT WLDMT/PTD	096370-1	2
13	CAP, 50X50(3-5MM THICK) #199274 SHR TUBE END	095371	4
14	PIN, DETENT	090197	2
15	PLATE, MOUNTING TVS	099145-1	4
16	BOLT, M16X120 -8.8- A2E ISO 24014	F81006-25	8

4**Saw Head***Blade Housing Cover*

17	NUT, M16 HEX NYLON ZINC LOCK	F81036-2	8	
18	WASHER, M16 FLAT ZINC	F81058-1	16	
19	PIN 5M6X50 DIN 6325 HRC60	F81048-8	2	

4.5 Saw Head Width Manual Adjustment Assembly

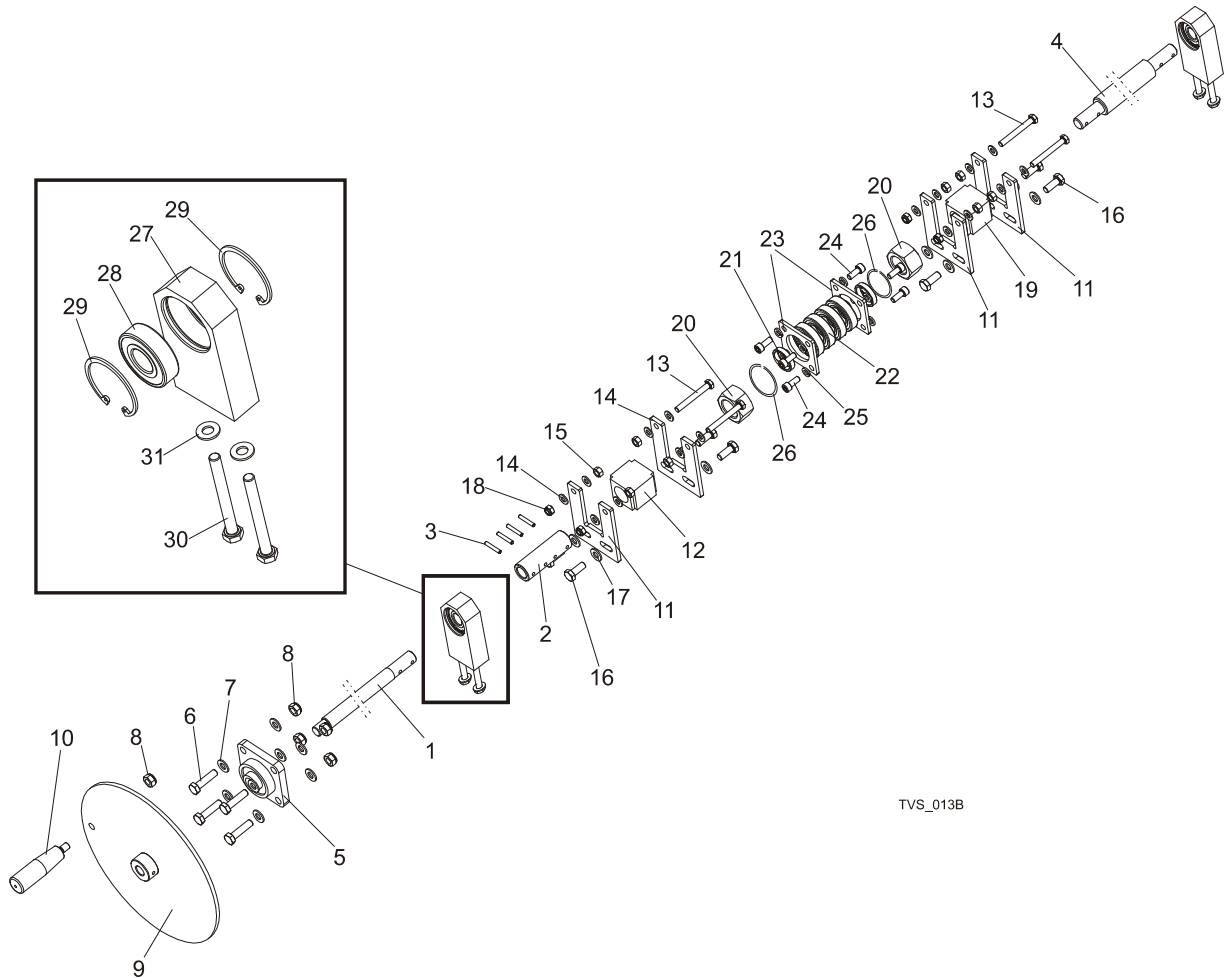

TVS_013B

REF	DESCRIPTION (◆ Indicates Parts Available In Assemblies Only)	PART #	QTY.
	SCREW, SAW HEAD WIDTH ADJUSTMENT TVS COMPLETE	097664	1
1	ROD, SAW HEAD WIDTH ADJUSTMENT	096359-1	1
2	FASTENER, SAW HEAD WIDTH ADJUSTMENT SCREW	097665-1	1
3	PIN, 5X30 ROLL ZINC	F81044-21	4
4	SCREW, SAW HEAD WIDTH ADJUSTMENT TVS	096154-1	1
5	BEARING, UCF 204 W/HOUSING	097667	1
6	BOLT, M10X40-8.8 HEX HEAD FULL THREAD ZINC	F81003-16	4
7	WASHER, M10 FLAT ZINC	F81055-1	8
8	NUT, M10 NYLON HEX ZINC LOCK	F81033-1	5
9	PLATE, SAW HEAD ADJUSTMENT SCREW WLDMT/PTD	098617-1	1
10	KNOB, PLASTIC CRANK HANDLE	086338	1
11	BRACKET, TURNBUCKLE MOUNT ZINC-PLATED	096861-1	2
12	TURNBUCKLE, M30 TVS	101439	1
13	BOLT, M8X65 8.8 HEX HEAD FULL THREAD ZINC	F81002-9	2

4

Saw Head*Saw Head Width Manual Adjustment Assembly*

14	WASHER, M8 FLAT ZINC	F81054-1	8	
15	NUT, M8 HEXAGON GRADE 5.8 FREE ZINC	F81032-1	4	
16	BOLT, M10-1.5X25MM HH GR8.8	F81003-11	4	
17	WASHER, M10 FLAT ZINC	F81055-1	4	
18	NUT, M8 HEXAGON NYLON LOCK ZINC	F81032-2	2	
19	TURNBUCKLE - M30 LH TVS	101440	1	
20	NUT, M30 HEX ZINC	F81038-3	2	
21	BUSHING, FI 34 X 38 X 8 SPACER	096356-1	2	
22	BEARING, 6006 2RSR	096191	4	
23	BRACKET, BEARING MOUNT BLOCK TVS-ZINC	096157-1	2	
24	BOLT, M8X20 -8.8-HEX SOCKET HEAD CAP ZINC	F81002-30	8	
25	WASHER, 8,2 ZINC	F81054-4	8	
26	WASHER, Z30.5 SPLIT LOCK	F81068-1	2	
	BLOCK, TVS SAW HEAD WIDTH ADJUSTMENT SCREW COMPLETE	500012	2	
27	BLOCK, TVS SAW HEAD WIDTH ADJUSTMENT SCREW	500011-1	1	
28	BEARING, 6204 2RS-CX ROLLING	088447	1	
29	RING, W47 INSIDE RETAINING	089653	2	
30	BOLT, M8 X 75 8.8 HEX HEAD ZINC	F81002-91	2	
31	WASHER, 8.4 FLAT ZINC	F81054-1	2	

4.6 Saw Head Width Automatic Adjustment Assembly (Optional)

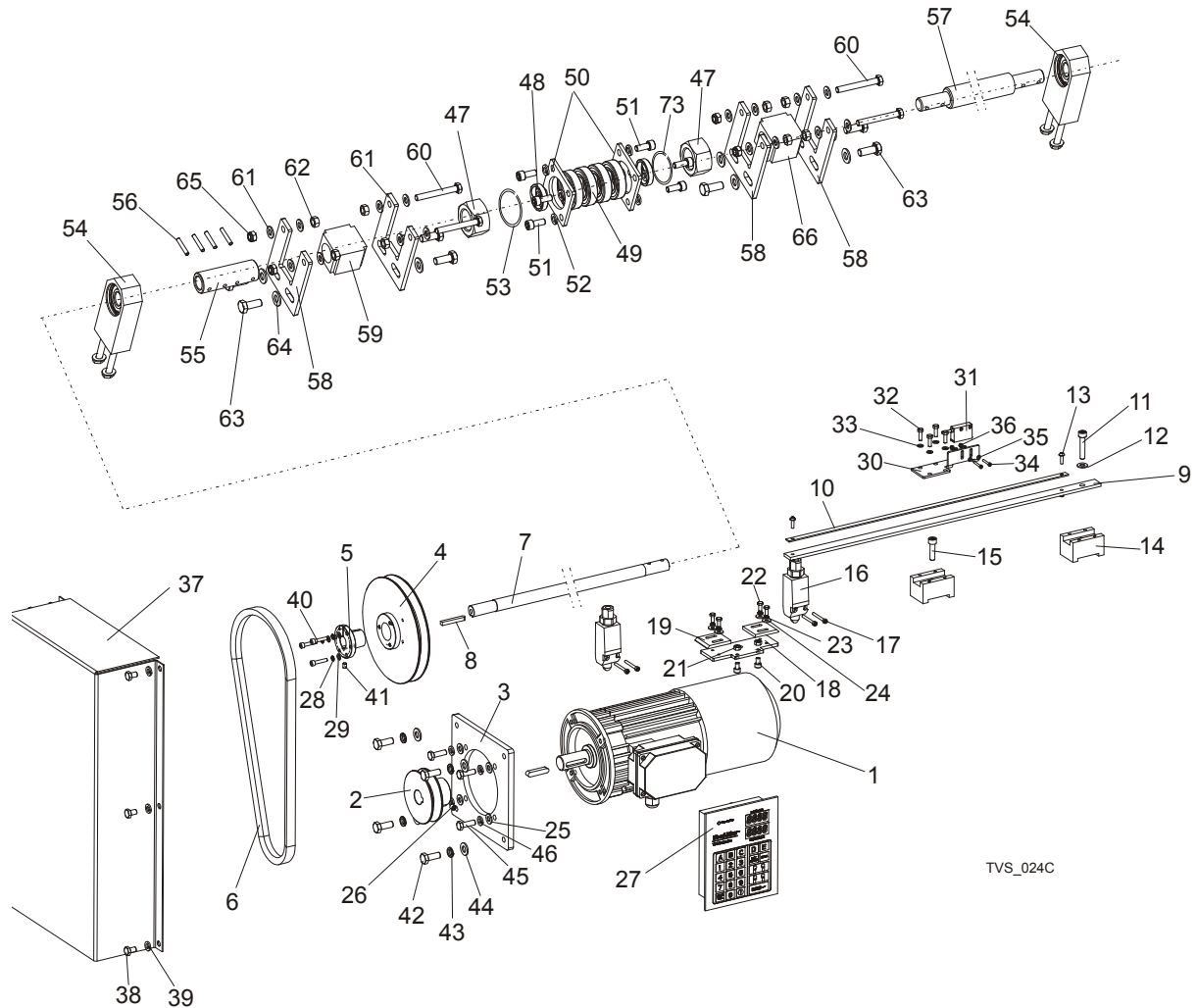

TVS_024C

REF	DESCRIPTION (◆ Indicates Parts Available In Assemblies Only)	PART #	QTY.
	SCREW, SAW HEAD WIDTH ADJUSTMENT TVS COMPLETE	099185	1
	SCREW, SAW HEAD WIDTH ADJUSTMENT TVS COMPLETE, TVS USA (UL)	099185-4C	1
1	MOTOR, SKH90-8L1 HPS 0,55KW, 750RPM.400V	098891	1
1	MOTOR, SKh90-8L1 0,55kW, 750RPM.400V (TVS-USA)	099515-UL	1
2	SHEAVE, SAW HEAD WIDTH ADJUSTMENT, TVS	098116-1	1
3	BRACKET, MOTOR	099181-1	1
4	SHEAVE, TYPE B $\Phi 180 \times \Phi 30$	098117-1	1
5	BUSHING, TAPER	099317	1
6	BELT, TVS	099320	1
7	ROD, SAW HEAD WIDTH ADJUSTMENT	099180-1	1
8	KEY, AB 6X6X45 PARALLEL	089229	1
	GUARD, TVS W/MAGNETIC STRIP	502924	1
9	GUARD, TVS MAGNETIC STRIP	502694	1
10	STRIP, MB320 (1m) MAGNETIC	096014-1	1
11	SCREW, M8X40 -8.8- HEX SOCKED HEAD CAP ZINC	F81002-29	1
12	WASHER, M8 FLAT ZINC	F81054-1	1

4

Saw Head*Saw Head Width Automatic Adjustment Assembly (Optional)*

13	WASHER, 4,3 FLAT ZINC	F81051-2	1	
14	MOUNTING BLOCK WITH MAGNETIC STRIP	502923	2	
15	SCREW, M8X30 -8.8- HEX SOCKED HEAD CAP ZINC	F81002-31	1	
16	LIMIT SWITCH	089816	2	
17	BOLT, M3X20-5.8-A-PAN HEAD	F81000-8	4	
	LIMIT SWITCH ASSEMBLY	098992	1	
18	PLATE, LIMIT SWITCH MOUNT	098988-1	1	
19	BAR, LIMIT SWITCH FLAT	098989	2	
20	SCREW, M6X10 -8.8- HEX SOCKED HEAD CAP ZINC	F81001-12	2	
21	NUT, M6, HEXAGON,FREE, GRADE 5(8.8)ZINC	F81031-1	2	
22	BOLT, M5 X 12-5.8-HEX HEAD FULL THREAD ZINC	F81000-5	4	
23	WASHER, M5 SPLIT LOCK	F81052-2	4	
24	WASHER, 5,5 FLAT ZINC SPECIAL	F81052-3	4	
25	WASHER, M8, FLAT ZINC	F81054-1	4	
26	SCREW, SET,M8X8-33H HEX SOCKET HEAD ZINC	F81014-1	1	
27	CONTROLLER, TBS01	503467	1	
28	WASHER, M5 SPLIT LOCK	F81052-2	3	
29	WASHER, M5, FLAT ZINC	F81052-1	3	
30	BRACKET, SENSOR	502922-1	1	
31	SENSOR ASSY, MSK-320	096014	1	
32	BOLT, M5X16 -8.8- HEX HEAD FULL THREAD ZINC	F81000-20	4	
33	WASHER, M5, FLAT ZINC	F81052-1	4	
34	SCREW, M3X20-5.8-A-PAN HEAD	F81000-8	2	
35	WASHER, 3,2 FLAT ZINC	F81050-2	4	
36	NUT, M3-6- HEX NYLON ZINC LOCK	F81028-2	2	
37	COVER, SAW HEAD WIDTH ADJUSTMENT TVS	098121-1	1	
38	BOLT, M8X12MM, HH FULL THREAD,GR8.8,ZINC	F81002-6	6	
39	WASHER, 8,2 SPLIT LOCK	F81054-4	6	
40	SCREW, M5X25-8.8-HEX SOCKED HEAD CAP ZINC	F81000-7	1	
41	SCREW, M6X8 PAN HEAD	F81013-1	1	
42	BOLT, M10-1.5X25MM HH GR8.8	F81003-11	4	
43	WASHER, M10 SPLIT LOCK ZINC	F81055-2	4	
44	WASHER, FLAT, M10, ZINC	F81055-1	4	
45	BOLT, M8 X 25MM HEX HEAD GR 5.8 ZINC	F81002-5	4	
46	WASHER, 8,2 SPLIT LOCK ZINC	F81054-4	4	
47	NUT, M30 HEX ZINC	F81038-3	2	
48	BUSHING, FI 34 X 38 X 8 SPACER	096356-1	2	
49	BEARING, 6006 2RSR	096191	4	
50	BRACKET, BEARING MOUNT BLOCK TVS-ZINC	096157-1	2	
51	BOLT, M8X20 -8.8-HEX SOCKET HEAD CAP ZINC	F81002-30	8	
52	WASHER, 8,2 ZINC	F81054-4	8	
53	WASHER, SPLIT LOCK Z30.5	F81068-1	2	
54	BLOCK, TVS SAW HEAD WIDTH ADJUSTMENT SCREW COMPLETE	500012	2	
55	FASTENER, SAW HEAD WIDTH ADJUSTMENT SCREW	097665-1	1	
56	PIN, 5X30 ROLL ZINC	F81044-21	4	
57	SCREW, SAW HEAD WIDTH ADJUSTMENT TVS	096154-1	1	

58	BRACKET, TURNBUCKLE MOUNT ZINC-PLATED	096861-1	2	
59	TURNBUCKLE, M30 TVS	101439	1	
60	BOLT, M8X65 8.8 HEX HEAD FULL THREAD ZINC	F81002-9	2	
61	WASHER, M8 FLAT ZINC	F81054-1	8	
62	NUT, M8 HEXAGON, GRADE 5.8 FREE ZINC	F81032-1	4	
63	BOLT, M10-1.5X25MM HH GR8.8	F81003-11	4	
64	WASHER, M10 FLAT ZINC	F81055-1	4	
65	NUT, M8 HEX NYLON LOCK ZINC	F81032-2	2	
66	TURNBUCKLE - M30 LH TVS	101440	1	

4.7 Saw Head Width Indicator

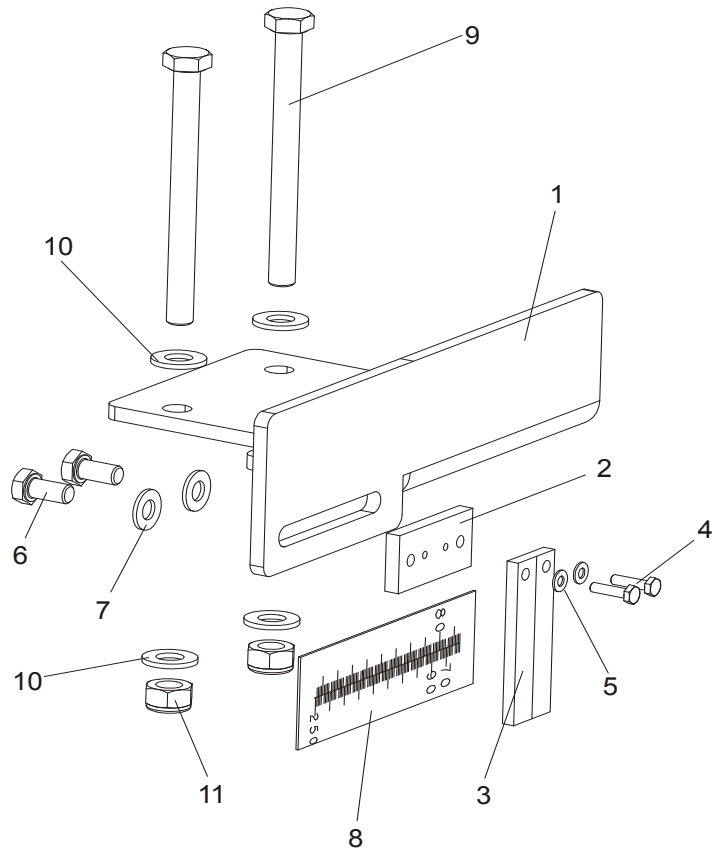

REF	DESCRIPTION (◆ Indicates Parts Available In Assemblies Only)	PART #	QTY.
	SCALE INDICATOR, TVS COMPLETE	098756	1
1	BRACKET, SCALE INDICATOR TVS	098622-1	1
2	BLOCK, BLADE WIDTH INDICATOR REDUCER	094438-1	1
3	INDICATOR, BLADE WIDTH SCALE	094821	1
4	BOLT, M4X16 5.8 HEX HEAD FULL THREAD ZINC	F81011-6	2
5	WASHER, 4,3 FLAT ZINC	F81051-2	2
6	BOLT, M8X16 -8.8-B-HEX HEAD FULL THREAD ZINC	F81002-20	2
7	WASHER, M8 FLAT ZINC	F81054-1	2
8	SCALE, TVS METRIC	098619	1
	SCALE, TVS INCH	502669	1
9	BOLT, M10X110 8.8 HEX HEAD ZINC	F81003-43	2
10	WASHER, M10 FLAT ZINC	F81055-1	4
11	NUT, M10 NYLON HEX ZINC LOCK	F81033-1	2

4.8 Saw Head Slide Brackets

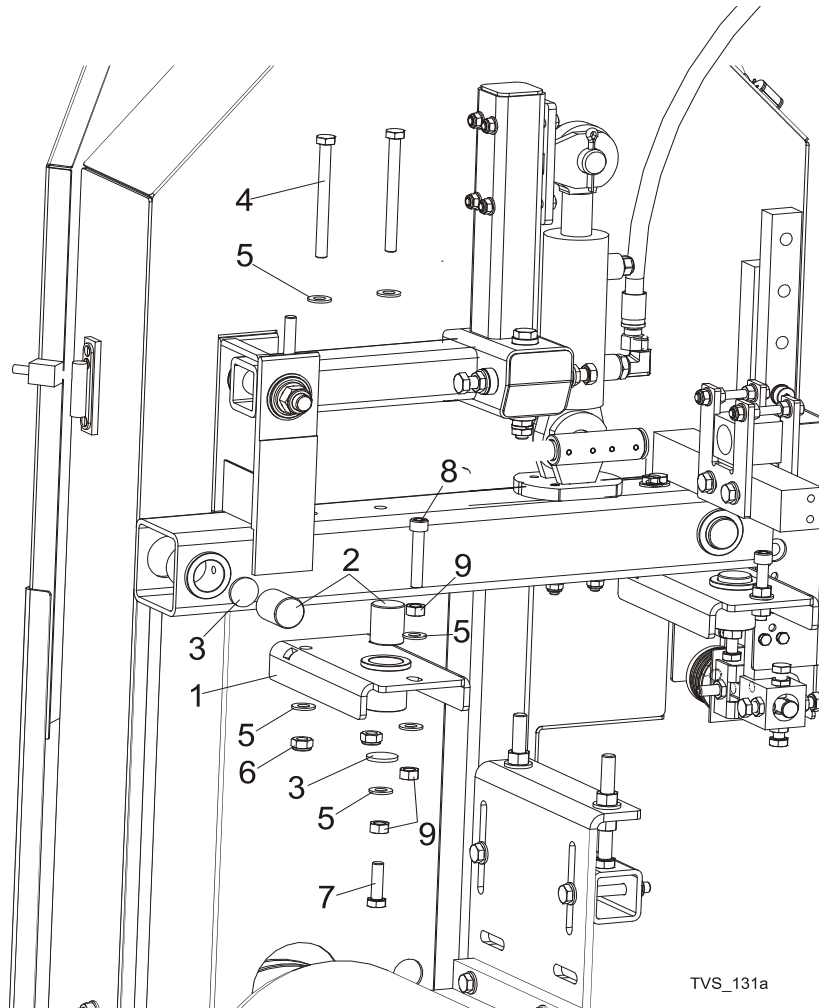

REF	DESCRIPTION (◆ Indicates Parts Available In Assemblies Only)	PART #	QTY.
1	BRACKET, SLIDE LOWER TVS	096838-1	2
2	ROD, SLIDE TVS	096128	4
3	WASHER, BUSHING SLIDE ZINC TVS	096129-1	4
4	BOLT, M10X110 8.8 HEX HEAD ZINC	F81003-43	4
5	WASHER, 10.5 FLAT ZINC	F81055-1	9
6	NUT, M10-8-B NYLON HEX ZINC LOCK	F81033-1	4
7	BOLT, M10X35-8.8 HEX HEAD FULL THREAD ZINC	F81003-17	2
8	SCREW, M10X55-8.8 HEX SOCKET HEAD CAP	F81003-55	2
9	NUT, M10-8-B-FE/ZN5 HEX	F81033-3	6

4.9 Hold-Down Roller (V-tables)

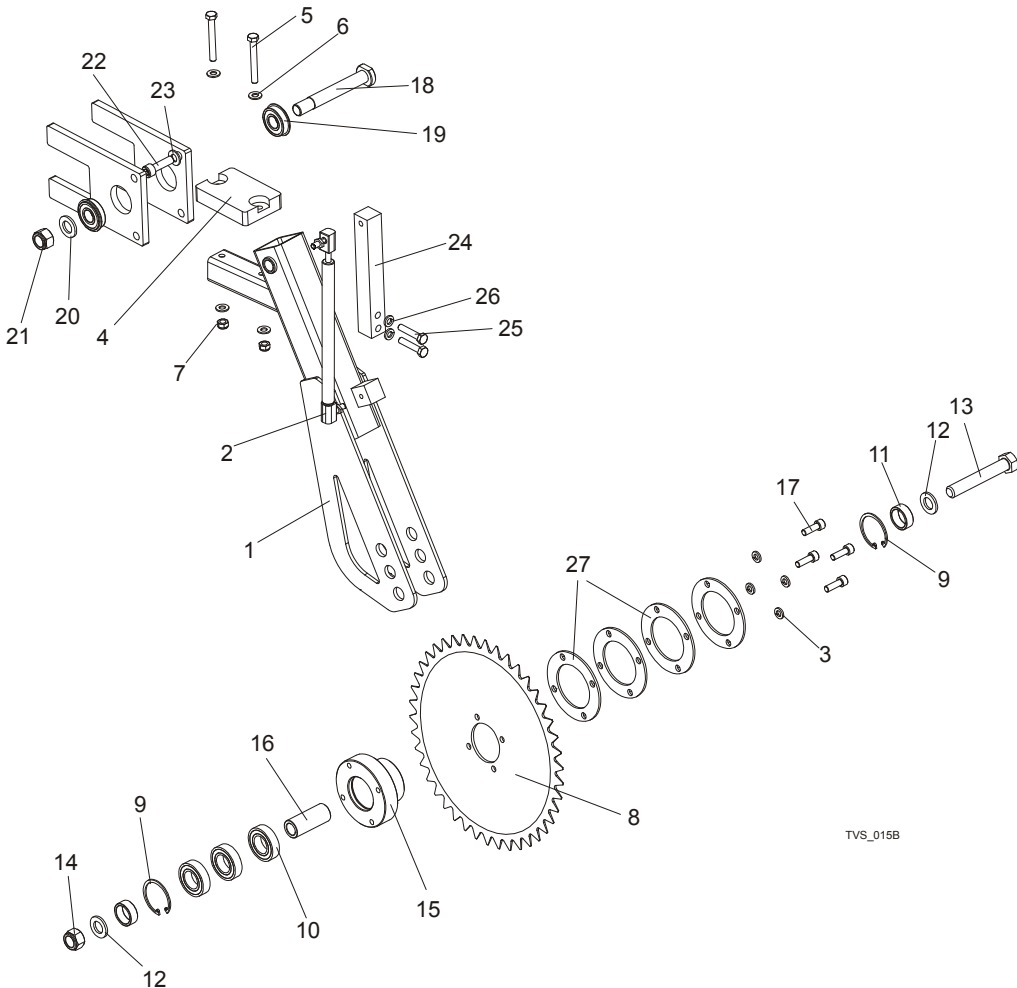

TVS_015B

REF	DESCRIPTION (◆ Indicates Parts Available In Assemblies Only)	PART #	QTY.
	ROLLER, HOLD-DOWN TVS	097954	1
1	ARM, HOLD-DOWN REAR	502765-1	1
2	SPRING, 340N GAS COMPLETE	089212	1
3	WASHER, 8,2 SPLIT LOCK ZINC	F81054-4	4
4	BUMPER, GRENE 70 3201 0010. SHR RUBBER	094969	1
5	BOLT, M8 X 65MM HH GRADE 5.8 ZINC	F81002-3	2
6	WASHER, M8 FLAT ZINC	F81054-1	4
7	NUT, M8 HEX NYLON LOCK ZINC	F81032-2	2
8	WHEEL, LOG HOLD-DOWN TVS	096352-1	1
9	RING, W47 SPRING RETAINING	089653	2
10	BEARING, 6005 2RS CX	089652	3
11	BUSHING, FI 25,5 X 32X12 SPACER ZINC	097942-1	2
12	WASHER, M16 FLAT ZINC	F81058-1	2
13	BOLT, M16X100MM HEX HEAD FULL THREAD ZINC	F81006-2	1
14	NUT, M16,HEX NYLON ZINC LOCK	F81036-2	1

15	SHAFT, LOG HOLD-DOWN WHEEL ZINC-PLATED	096351-1	1	
16	BUSHING, FI 25X16,5X60 SPACER ZINC	098610-1	1	
17	BOLT, M8X25 -8.8- HEX SOCKET HEAD CAP ZINC	F81002-21	4	
18	PIN, IDLER ARM MOUNT	086404	1	
19	BEARING W/SNAP RING 6203-2RS	086395	2	
20	WASHER, M16 FLAT ZINC	F81058-1	1	
21	NUT, M16 HEX NYLON ZINC LOCK	F81036-2	1	
22	BOLT, M10X35 HEX SOCKET HEAD CAP ZINC	F81003-56	1	
23	WASHER, M10 FLAT ZINC	F81055-1	1	
24	BRACKET, GAS SPRING ZINC	096160-1	1	
25	BOLT, 8MM X 1.25 X 40MM HH ZINC	F81002-15	2	
26	WASHER, 8,2 SPLIT LOCK ZINC	F81054-4	2	
27	SPACER	099530-1	4	

4 Saw Head

Saw Head Hold-Down Roller (Spiky Chain Table)

4.10 Saw Head Hold-Down Roller (Spiky Chain Table)

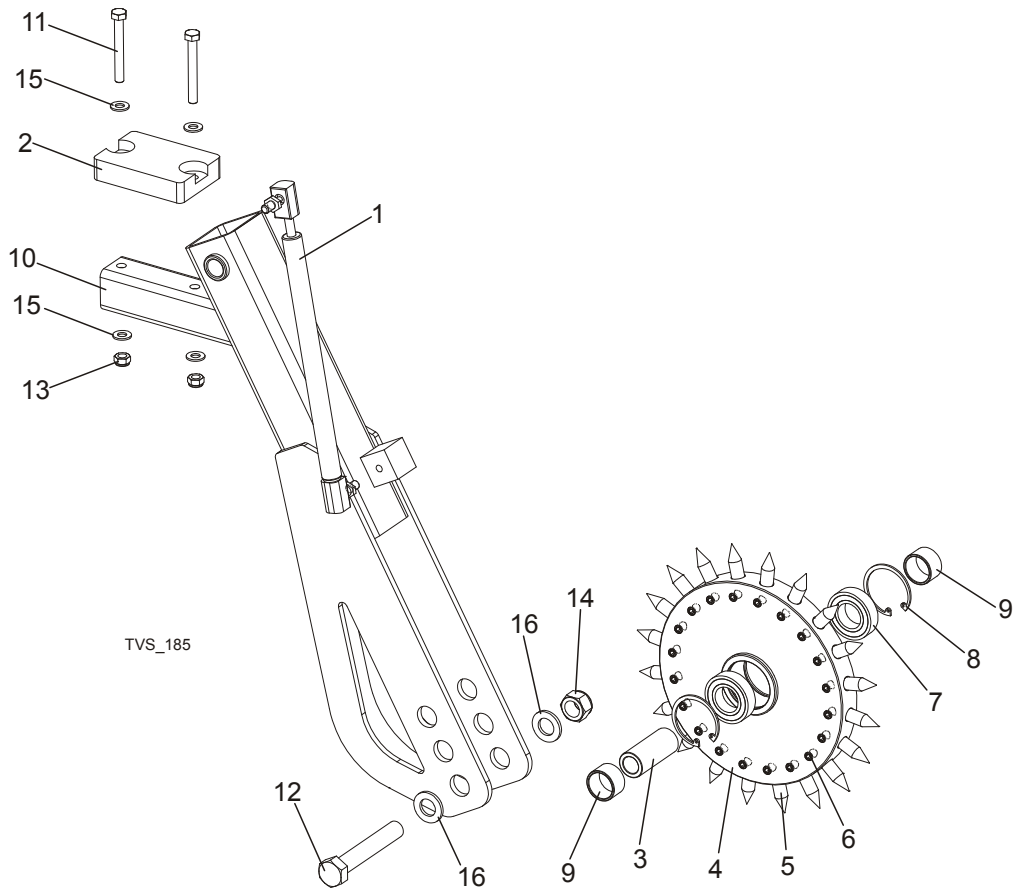

REF	DESCRIPTION (◆ Indicates Parts Available In Assemblies Only)	PART #	QTY.
	ROLLER, TVS-SC SAW HEAD HOLD-DOWN	502766	1
1	SPRING, 340N GAS COMPLETE	089212	1
2	BUMPER, GRENE 70 3201 0010. SHR RUBBER	094969	1
3	BUSHING, FI 25X16,5X60 SPACER ZINC	098610-1	1
	WHEEL, TVS-SC HOLD DOWN COMPLETE	502639	1
4	WHEEL, TVS-SC HOLD DOWN	502638-1	1
5	SPIKE, HOLD- DOWN WHEEL	502651-1	20
6	SCREW, M8x8-33H HEX SOCKET HEAD SET ZINC	F81014-1	20
7	BEARING, 6005 2RS CX	089652	2
8	RING, W47 RETAINING	089653	2
9	BUSHING, ϕ 20.5X ϕ 30X18 SPACER	502645-1	2
10	ARM, HOLD-DOWN ROLLER REAR	502765-1	1
11	BOLT, M8 X 65MM,HH,GRADE 5.8, ZINC	F81002-3	2
12	BOLT, M16X100MM,HEX HEAD FULL THRD,ZINC	F81006-2	1
13	NUT,M8-8-B, HEX,NYLON LOCK ZINC	F81032-2	2
14	NUT, M16,HEX, NYLON ZINC LOCK	F81036-2	1
15	WASHER, 8.4 FLAT,ZINC	F81054-1	4
16	WASHER, 17 FLAT ZINC	F81058-1	2

4.11 Blade Drive Motor

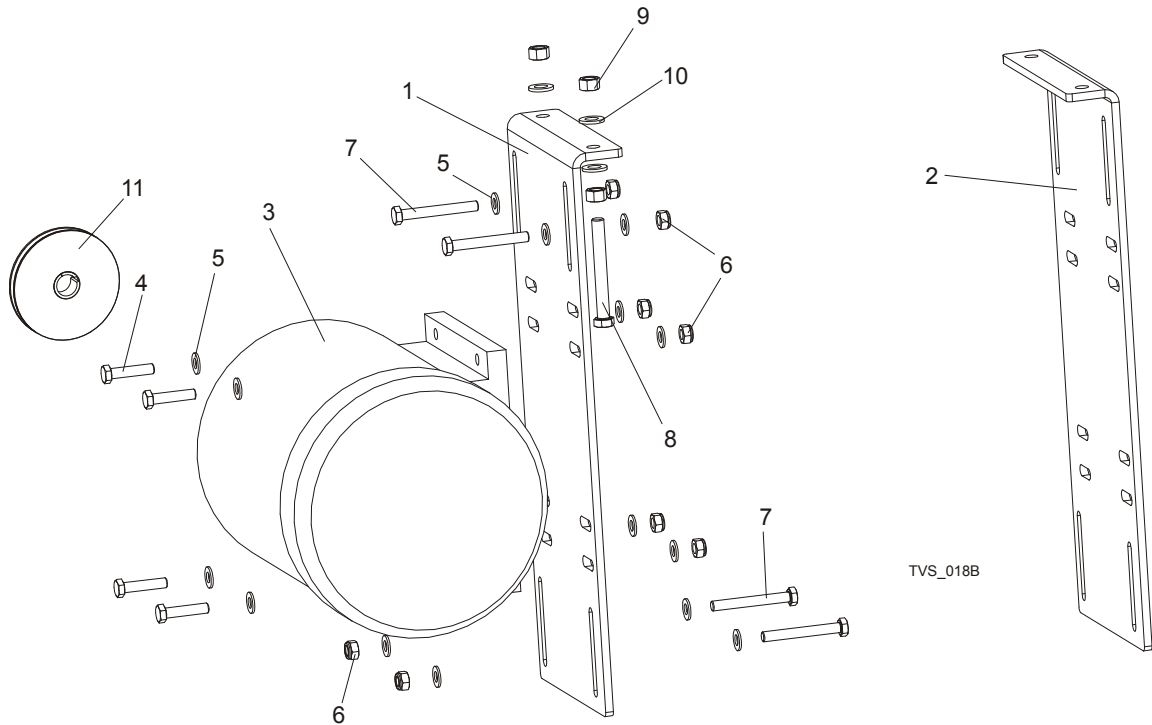

REF	DESCRIPTION (◆ Indicates Parts Available In Assemblies Only)	PART #	QTY.
1	PLATE, MOTOR MOUNT RIGHT - PTD	096123-1	1
	PLATE, MOTOR MOUNT RIGHT - PTD (TVS-USA)	099398-1	1
2	PLATE, MOTOR MOUNT LEFT - PTD	098436-1	1
	PLATE, MOTOR MOUNT LEFT - PTD (TVS-USA)	099397-1	1
3	MOTOR, 7,5KW SG132S-2B HM	090993	2
	MOTOR, 11KW PSg-132 S2 - HM	089049	2
	MOTOR, 12kW 1LE1002-1CA63-4AA4-Z (USA)	P85186-UL	2
	MOTOR, 15KW(20HP)380-420V ELECTRIC (TVS-USA)	086856-UL	2
4	BOLT, M10X45MM HEX HEAD FULL THREAD ZINC	F81003-3	8
5	WASHER, M10 FLAT ZINC	F81055-1	32
6	NUT, M10 NYLON HEX ZINC LOCK	F81033-1	16
7	BOLT, M10X80 -8.8- HEX ZINC	F81003-50	8
8	BOLT, M12X100 8.8 HEX HEAD FULL THREAD ZINC	F81004-45	4
9	NUT, M12 HEX GRADE 5.8 ZINC	F81034-1	4
10	WASHER, M12 FLAT ZINC	F81056-1	8
11	PULLEY, SPB ϕ 140X1/ ϕ 38 (F02325+T31079)	500571 ¹	2
	PULLEY, SPB ϕ 170X1/ ϕ 38 (F01794+T31079)	500575 ²	2
	PULLEY, SPB190/1 W/2012/38 TAPER SPLIT BUSHING	099601 ³	2
	PULLEY, SPB125X1/FI38 F02319+T31079 TAPER SPLIT BUSHING	501556 ⁴	2
	PULLEY, ϕ 150/ FI42 F02329+T31081 (TVS-USA)	099503	1

¹ Standard Equipment. Blade Linear Velocity v=20.5 m/s.

² Blade Linear Velocity v=25 m/s.

³ Blade Linear Velocity v=28 m/s.

⁴ Blade Linear Velocity v=23 m/s.

4.12 Saw Head Support Rollers

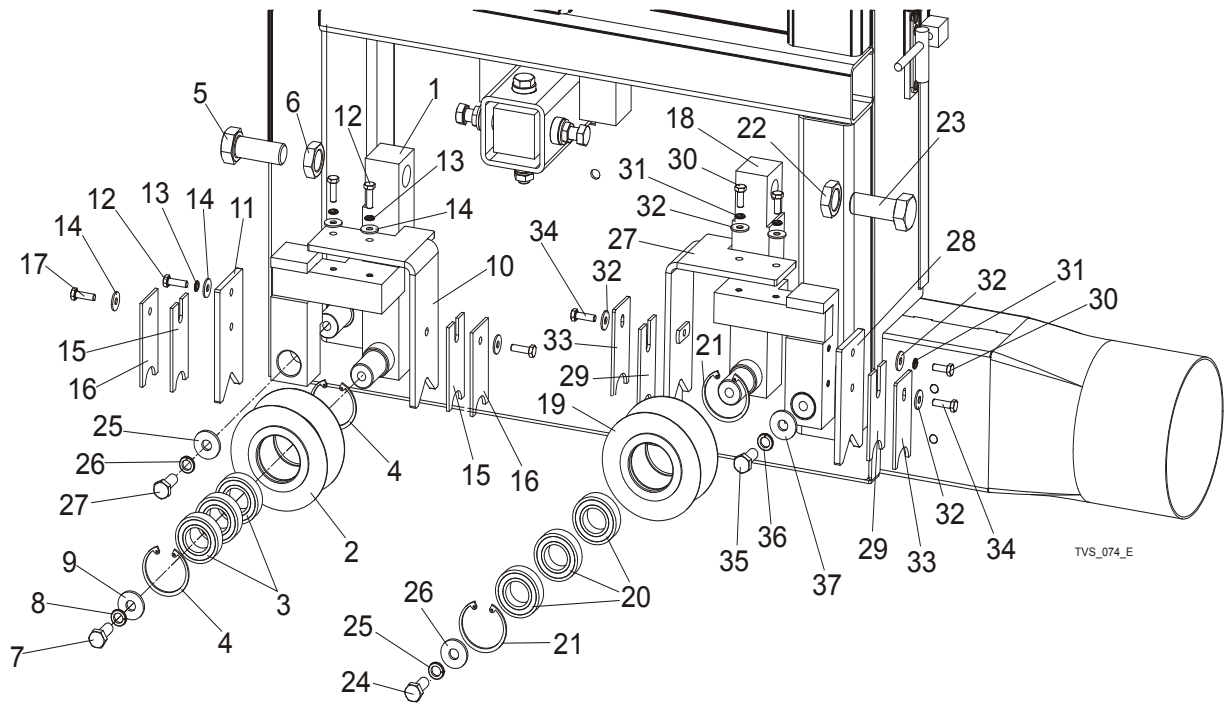

REF	DESCRIPTION (◆ Indicates Parts Available In Assemblies Only)	PART #	QTY.
	ROLLER, TVS SAW HEAD ADJUST SUPPORT, COMPLETE	100179	2
1	SUPPORT, TVS SAW HEAD ROLLER	100177-1	1
	ROLLER, TVS SAW HEAD SUPPORT, COMPLETE	096835	1
2	ROLLER, TVS SAW HEAD SUPPORT, PTD	096834-1	1
3	BEARING, 6005 2RS CX	089652	3
4	RING, W47 SPRING RETAINING	089653	2
5	BOLT, M10X1,5X50-8.8-B ZINC-PLATED	F81007-2	1
6	NUT, M20X1,5 ZINC-PLATED THIN	F81037-7	1
7	BOLT, M10X25-8.8-HEX HEAD FULL THREAD ZINC	F81003-11	1
8	WASHER, 10.2 SPLIT LOCK ZINC	F81055-2	1
9	WASHER,10.5 ZINC FLAT SPECIAL	F81055-6	1
10	SUPPORT, WIPER RIGHT	101092-1	1
11	SUPPORT, WIPER LEFT	101093-1	1
12	BOLT, M6 X 16 8.8 HEX HEAD FULL THREAD ZINC	F81001-15	3
13	WASHER, Z6.1 SPLIT LOCK ZINC	F81053-3	3
14	WASHER, 6.5 FLAT ZINC	F81053-11	5
15	WIPER, TOP RAIL	101090	2
16	PLATE, TRACK WIPER PTD	088559-1	2
17	BOLT, M6X20-8.8 HEX HEAD FULL THREAD ZINC	F81001-2	2
	ROLLER, TVS SAW HEAD ADJUST SUPPORT LEFT, COMPLETE	509887	2
18	BRACKET, ROLLER WLDMT/PTD	509888-1	1
	ROLLER, TVS SAW HEAD SUPPORT, COMPLETE	096835	1
19	ROLLER, TVS SAW HEAD SUPPORT PTD	096834-1	1

20	BEARING, 6005 2RS CX	089652	3	
21	Ring, W47 Spring Retaining	089653	2	
22	NUT, M20X1,5 ZINC-PLATED THIN	F81037-7	1	
23	BOLT, M10X1,5X50-8.8-B ZINC-PLATED	F81007-2	1	
24	BOLT, M10X25-8.8-HEX HEAD FULL THREAD ZINC	F81003-11	1	
25	WASHER, 10.2 SPLIT LOCK ZINC	F81055-2	1	
26	WASHER,10.5 ZINC FLAT SPECIAL	F81055-6	1	
27	SUPPORT, WIPER LEFT	509889-1	1	
28	SUPPORT, WIPER LEFT	101093-1	1	
29	WIPER, TOP RAIL	101090	2	
30	BOLT, M6 X 16 8.8 HEX HEAD FULL THREAD ZINC	F81001-15	3	
31	WASHER, Z6.1 SPLIT LOCK ZINC	F81053-3	3	
32	WASHER, 6.5 FLAT ZINC	F81053-11	5	
33	PLATE, TRACK WIPER PTD	088559-1	2	
34	BOLT, M6X20-8.8 HEX HEAD FULL THREAD ZINC	F81001-2	2	
35	BOLT, M10 X 25 8.8 HEX HEAD FULL THREAD ZINC	F81003-31	2	
36	WASHER, 10.2 SPLIT LOCK ZINC	F81055-2	2	
37	WASHER,10.5 ZINC FLAT SPECIAL	F81055-6	2	

4.13 Electric Box



REF	DESCRIPTION (◆ Indicates Parts Available In Assemblies Only)	PART #	QTY.	
	ELECTRIC BOX TVS 400V CE	509150	1	
	ELECTRIC BOX TVS 230V CE	509150-2	1	
	ELECTRIC BOX TVS 400V	509150-3	1	
	ELECTRIC BOX TVS 460V	509150-4	1	
	ELECTRIC BOX TVS 230V	509150-5	1	
1	SWITCH ABB OT45E3	095473	1	
	HANDWHEEL OHB2AJ ABB	088265-1	1	
	AXIS OXS5X160 ABB	088265-2	1	
2	CONTROL LIGHT, WHITE	090488	1	

4.14 Control Box

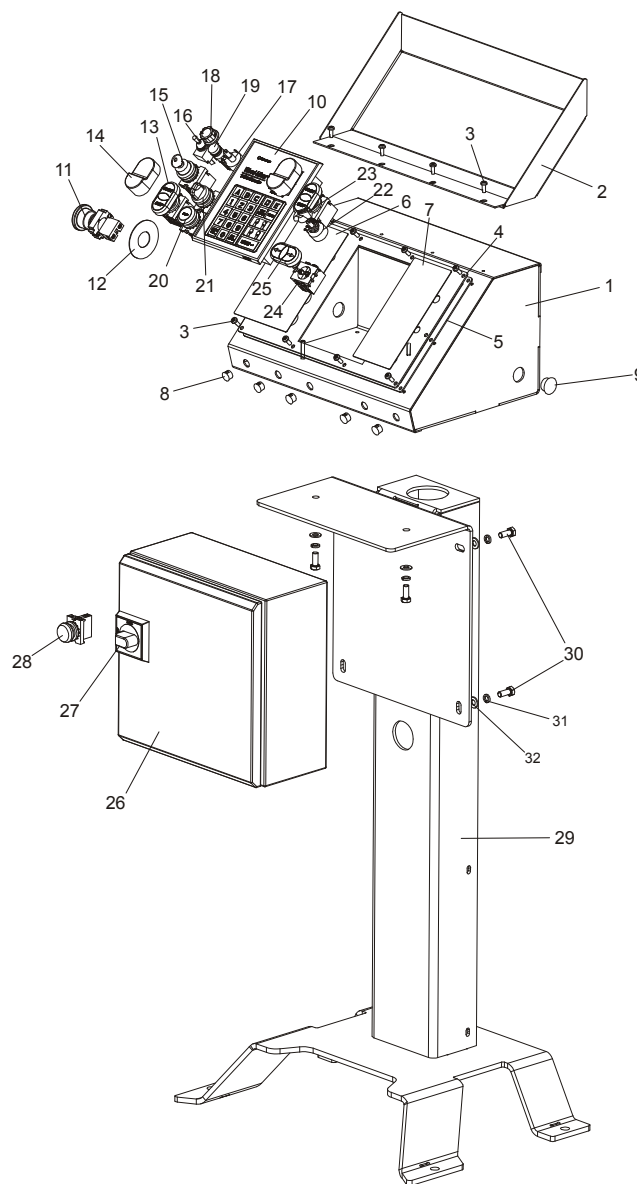

REF	DESCRIPTION (◆ Indicates Parts Available In Assemblies Only)	PART #	QTY.
	CONTROL BOX, TVS COMPLETE	509141	1
1	CONTROL BOX, TVS	510061-1	1
2	COVER, CONTROL BOX - COMPLETE	097135-1	1
3	BOLT, #10-24 X 1/2 PH PAN HD, TYPE 23	F05015-17	12
4	PANEL, TVS FRONT CONTROL	503535-1	1
5	GASKET, LT20 CONTROL BOX	097132	1
6	DECAL, TVS CONTROL BOX LEFT	503538A	1
7	DECAL, TVS CONTROL BOX RIGHT	503538B	1
8	CAP, DP 812 HEJMAN 12.7 DIA. HOLE	086773	5
9	CAP, 22.2 HOLE SR1086	093544	1

4 Saw Head Control Box

10	CONTROLLER, TBS01	503467 ¹	1	
	CAP, TVS CONTROL BOX	504378	1	
	DECAL, TVS CONTROL BOX	504379	1	
	MEMBRANE CONTROLLER TVS	083731	1	
11	SWITCH EMERGENCY XB2 BS542	086556	1	
12	LEGEND PLATE	086561	1	
	SWITCH, 24V START/STOP	090452	2	
13	CONTROL LIGHT M22 WHITE-LED 24V	090448	1	
14	MEMBRANE M22-T-DD	090462	1	
15	SWITCH, M22 3-POSITION KEY	091361	1	
16	SWITCH, DPDT ON/OFF/ON 15A TOGGLE	024588	1	
17	POT, 500K 2W 10% CP PANEL MOUNT	024553	1	
18	KNOB, 1/4 ID FLUTED ROUND PLASTIC	033478	1	
19	CONTROL BULB XB6 AV 3BB	087348	1	
20	SWITCH, M22 STOP	090926	1	
21	SWITCH, M22 3 POSITIONS, ILLUMINATED	091359	1	
22	POTENTIOMETER, 1K LTAGA	E20519	1	
23	KNOB, SPEED CONTROL	P06257	1	
24	ELEMENT, M22-K10 CONTACT	091362	1	
25	BUTTON, M22-DD-S-X7/X7	090917	1	
	BOX, POWER SUPPLY TVS	507258	1	
26	BOX, SAREL S83002 /300x300x150/	092627	1	
27	HANDLE, OHB S2A1 ABB SWITCH	502312-1	1	
28	CONTROL LIGHT, WHITE 1SFA619402L5415	509129	1	
29	WELDMENT, CONTROL BOX	505555-1	1	
30	BOLT, M8X20MM, HEX HEAD,GR 5.8 ZINC	F81002-4	4	
31	WASHER 8,2 SPLIT LOCK ZINC	F81054-4	4	
32	WASHER, 8.4 FLAT ZINC	F81054-1	4	

¹ In machines with Automatic Saw Head Width Adjustment Option only.

4.15 Laser Assembly (Optional)

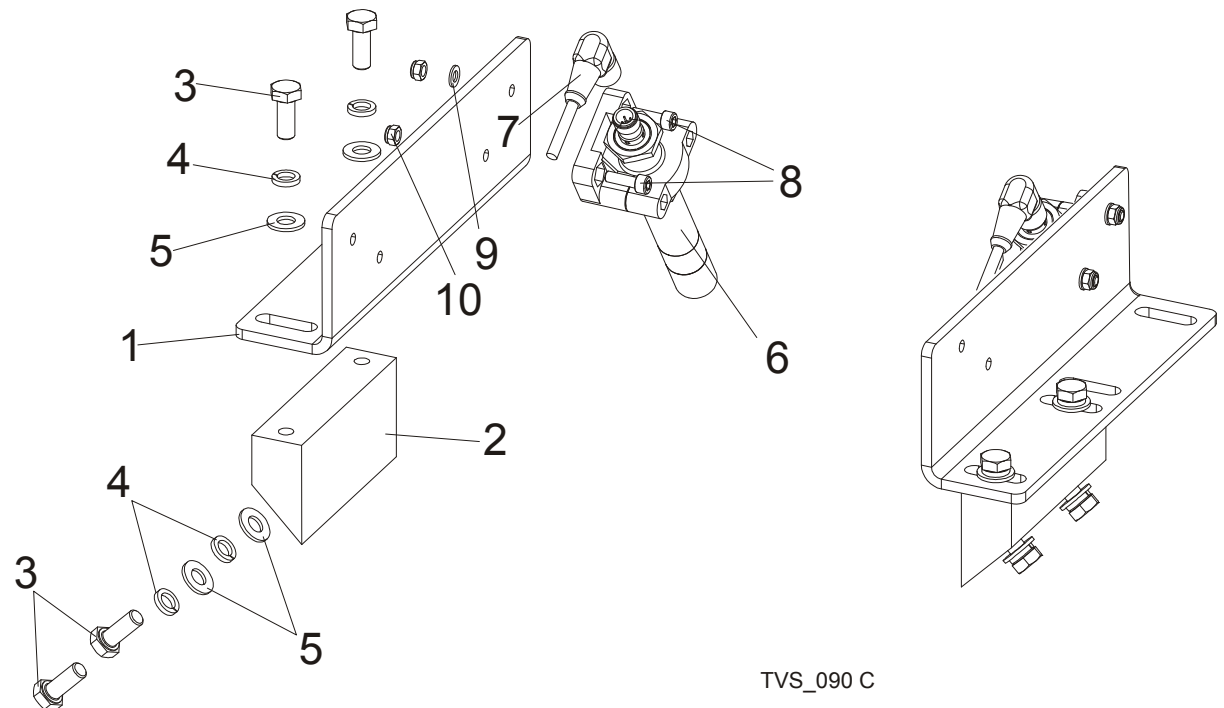

REF	DESCRIPTION (◆ Indicates Parts Available In Assemblies Only)	PART #	QTY.
	TVS LASER ASSEMBLY, COMPLETE	100079	1
1	PLATE, TVS LASER MOUNTING	098304	2
2	BRACKET, TVS LASER	098303	2
3	BOLT, M8X20MM, HEX HEAD GR 8.8 FULL THREAD ZINC	F81002-1	8
4	WASHER, 8.2 SPLIT LOCK ZINC	F81054-4	8
5	WASHER, 8.4 FLAT ZINC	F81054-1	8
6	LASER, Z5M18B-F-532-IG90 GREEN - LINEAR	501025	2
7	SENSOR CABLE, 4-WIRES 5M	087652	2
8	SCREW, M5X16-8.8 HEX SOCKET HEAD CAP ZINC	F81000-25	4
9	WASHER, 5.3 FLAT ZINC	F81052-1	4
10	NUT, M5-8- DIN985 ZINC	F81030-2	4

SECTION 5 TVS-SC INFEED & OUTFEED TABLES

5.1 Conical Roller Table

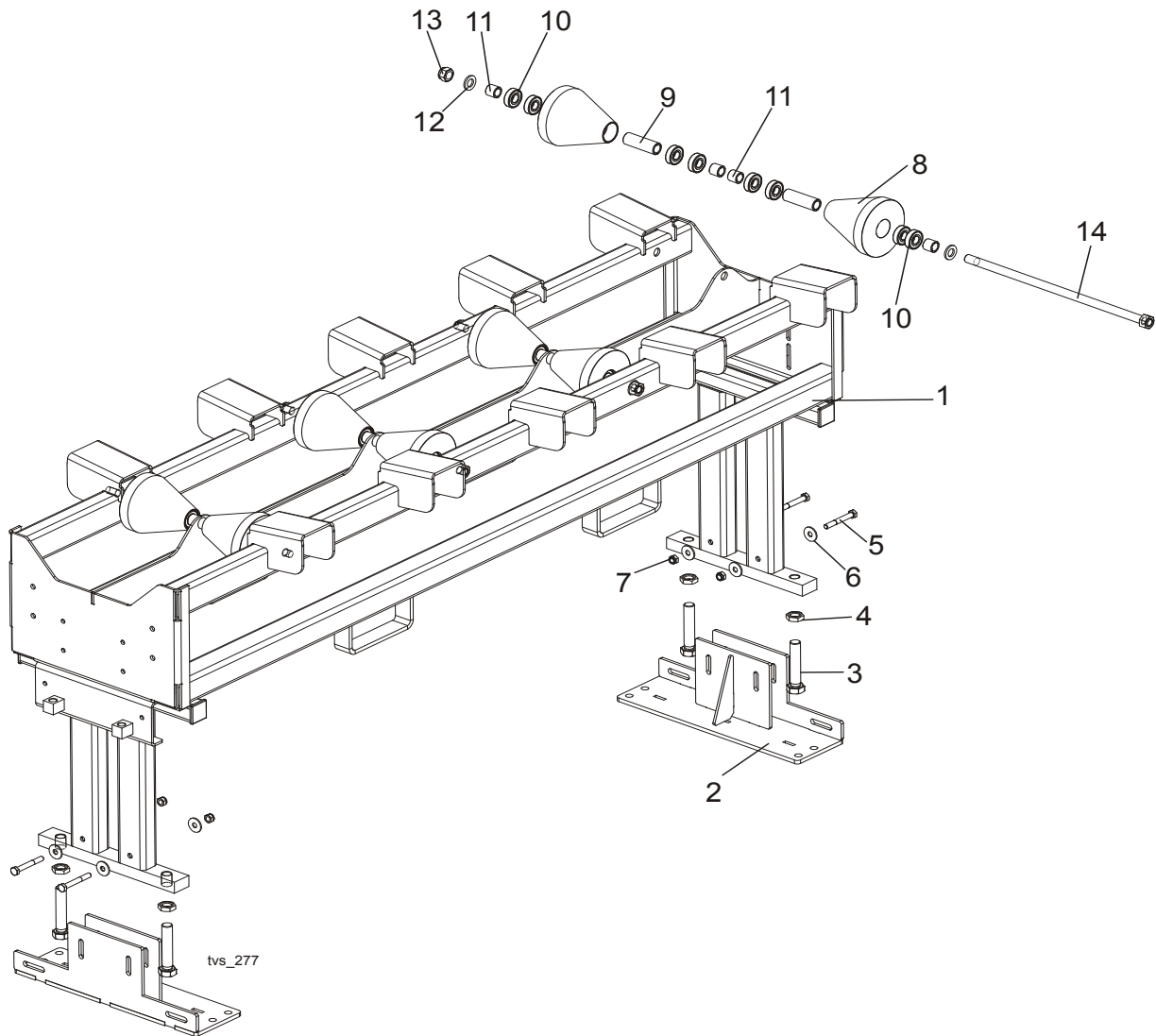

REF.	DESCRIPTION (◆ Indicates Parts Available In Assemblies Only)	PART #	QTY.
	MODULE, INFEED TABLE EXTENSION	509510	1
1	FRAME, INFEED TABLE EXTENSION MODULE	509509-1	1
2	FOOT WELDMENT, TVS TABLE	502750-1	2
3	BOLT, M24X120 8.8 HEX HEAD FULL THREAD ZINC	F81009-6	4
4	NUT, M24-04-B HEX THIN ZINC	F81039-3	4
5	BOLT, M12x90-8.8 HEX HEAD ZINC	F81004-2	4
6	WASHER, 13 SPECIAL FLAT ZINC	F81056-14	8
7	NUT, M12-8 HEX NYLON ZINC LOCK	F81034-2	4
	ROLLER ASSEMBLY, CONICAL W/PIVOT BOLT	508534	4
8	ROLLER, CONICAL ZINC-PLATED FEED	508533-1	2
9	BUSHING, 21X30X91.3 SPACER ZINC-PLATED	508645-1	2

TVS-SC INFEED & OUTFEED TABLES

Conical Roller Table

5

10	BEARING, 6204 2RS CX	088447	8	
11	BUSHING, LT15 SPACER ZINC-PLATED	094156-1	4	
12	WASHER, 21 FLAT ZINC	F81059-2	2	
13	NUT, M20-8-A HEX NYLON ZINC LOCK	F81037-2	1	
14	BOLT, FEED ROLLER PIVOT	508535-1	1	

5.2 TVSIS2.4 & TVSIS3.6 Infeed Table

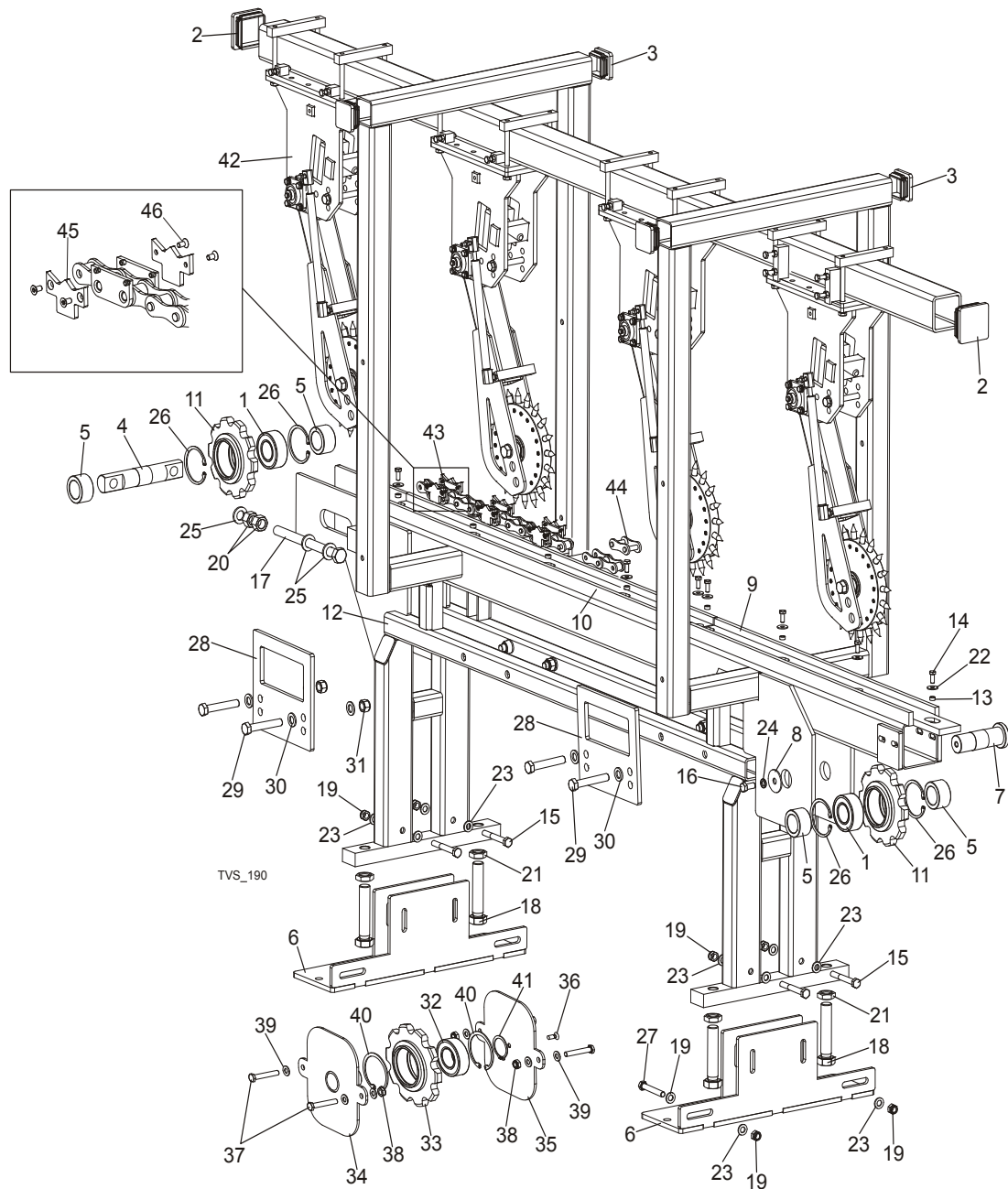

REF.	DESCRIPTION (◆ Indicates Parts Available In Assemblies Only)	PART #	QTY.
	TABLE, TVSIS2.4 INFEED	503640	1
	TABLE, TVSIS3.6 INFEED	503655	1
1	BEARING, 3208.2RSR.TVH (FAG)	088449	2
2	CAP, FRAME TUBE	089644	2
3	CAP, 1540 DIA. OUTRIGGER LEG	089710	4
4	SHAFT, IDLER SPROCKET ZINC-PLATED	089915-1	1
5	BUSHING, SPROCKET ZINC-PLATED SPACER	089916-1	4
6	FOOT WELDMENT, TVS TABLE	502750-1	2

TVS-SC INFEED & OUTFEED TABLES

TVSIS2.4 & TVSIS3.6 Infeed Table

5

7	PIN, IDLER SPROCKET PIVOT	501689-1	1	
8	WASHER, ZINC-PLATED	501761-1	1	
9	CHANNEL, CHAIN GUIDE - SHORT	502561	1	
10	CHANNEL, CHAIN GUIDE	502562	1	
11	SPROCKET, 10Z 20B/2" F80	502566-1	2	
12	TABLE WELDMENT, 2.4 INFEED	503641-1	1	◆
	TABLE WELDMENT, 3.6 INFEED	503656-1	1	◆
13	BUSHING, 12.5 X 8.4 X 6 SPACER	504040-1	7/11	
14	BOLT, M8X20-5.8 HEX HEAD FULL THREAD ZINC	F81002-1	9/14	
15	BOLT, M12x90-8.8 HEX HEAD ZINC	F81004-2	4	
16	BOLT, M12X25-8.8-HEX HEAD FULL THREAD ZINC	F81004-31	1	
17	BOLT, M20X240-8.8 HEX HEAD FULL THREAD ZINC	F81007-1	2	
18	BOLT, M24X120 8.8 HEX HEAD ZINC	F81009-6	4	
19	NUT, M12-8 HEX NYLON ZINC LOCK	F81034-2	6	
20	NUT, M20-8-HEX ZINC	F81037-1	4	
21	NUT, M24-04-B HEX THIN ZINC	F81039-3	4	
22	WASHER, 8.5 SPECIAL FLAT ZINC	F81054-11	9/14	
23	WASHER, 13 FLAT ZINC	F81056-1	12	
24	WASHER, Z12.2 SPLIT LOCK ZINC	F81056-2	1	
25	WASHER, 21 FLAT ZINC	F81059-2	6	
26	RING, W80 INSIDE RETAINING	F81090-25	4	
27	BOLT, M12X80-8.8 HEX HEAD ZINC	F81004-46	2	
28	PLATE, TVS MOUNTING	099145-1	4	
29	BOLT, M16x90 HEX HEAD ZINC	F81006-17	8	
30	WASHER, 17 FLAT ZINC	F81058-1	16	
31	NUT, M16-8 HEX NYLON ZINC LOCK	F81036-2	8	
	SUPPORT WHEEL ASSEMBLY (3.6 TABLE ONLY)	503337	1	
32	BEARING, 3208.2RSR.TVH (FAG)	088449	1	
33	SPROCKET, 10Z 20B/2" Φ80	502566-1	1	
34	BOLT, SPROCKET PIVOT	503340-1	1	
35	PLATE, SUPPORT WHEEL MOUNTING	503341-1	1	
36	SCREW, M8x25 CROSS RECESSED COUNTERSUNK HEAD ZINC	F81002-51	1	
37	BOLT, M10x75-8.8-HEX HEAD ZINC	F81003-15	4	
38	NUT, M10-8-B HEX NYLON ZINC LOCK	F81033-1	4	
39	WASHER, 10.5 FLAT ZINC	F81055-1	8	
40	RING, W80 INSIDE RETAINING	F81090-25	2	
41	RING, Z40 OUTSIDE RETAINING	F81090-40	1	
42	ROLLER, HOLD-DOWN COMPLETE See Section 5.3	510308	4/3 ¹	
43	CHAIN, 20B P=2" ROLLER W/SPIKES (275 LINKS) - 2.4 TABLE	507880	1	
	CHAIN, 20B P=2" ROLLER W/SPIKES (299 LINKS) - 3.6 TABLE	510955	1	
	CHAIN, 20B P=2" ROLLER W/SPIKES (275 LINKS) - 2.4E TABLE	508895	1	
	CHAIN, 20B P=2" ROLLER W/SPIKES (393 LINKS) - 3.6E TABLE	509372	1	
44	LINK, TVS-SC CHAIN MASTER	502563	1	
45	PLATE, CHAIN TOOTHED	507876	6	
46	SCREW, M6X12-10.9 DIN7991 ZINC-PLATED	F81001-54	12	

¹ 3 rollers in TVSSC E version (Economic).

5.3 Hold-Down Roller

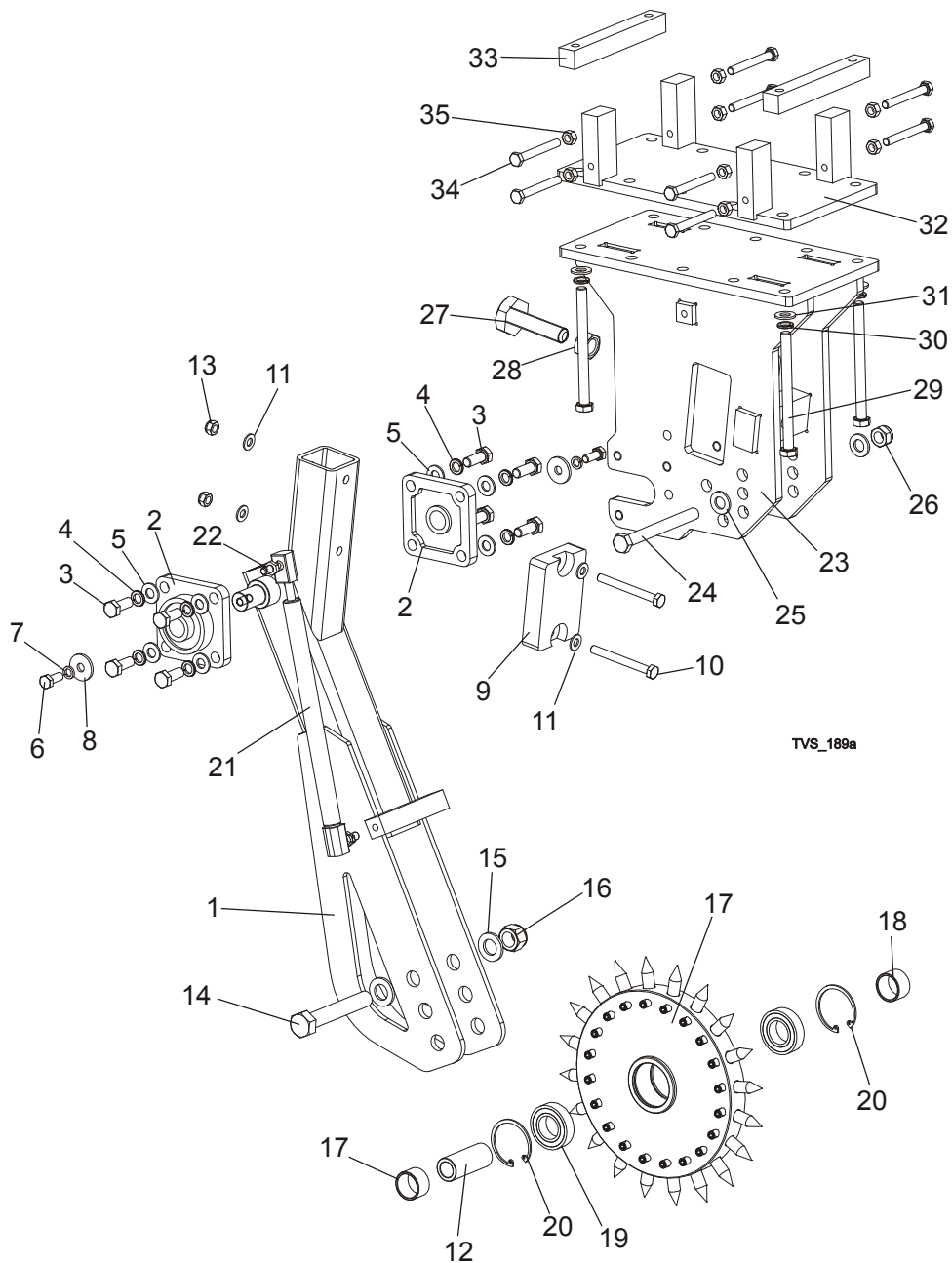

TVS_189a

REF.	DESCRIPTION (◆ Indicates Parts Available In Assemblies Only)	PART #	QTY.
	ROLLER, HOLD-DOWN COMPLETE	510308	1
	ROLLER, TVS HOLD-DOWN	510309	1
1	ARM WELDMENT, HOLD-DOWN ROLLER	510307-1	1
2	BEARING, UCF 204 W/HOUSING	097667	2
3	BOLT, M10X25-8.8 HEX HEAD FULL THREAD ZINC	F81003-11	8
4	WASHER, 10.2 SPLIT LOCK ZINC	F81055-2	8
5	WASHER, 10.5 FLAT ZINC	F81055-1	8
6	BOLT, M8x20-5.8 HEX HEAD FULL THREAD ZINC	F81002-1	2
7	WASHER, 8.2 SPLIT LOCK ZINC	F81054-4	2
8	WASHER, 9 DIN440 A2 STAINLESS STEEL	F81054-9	2

TVS-SC INFEED & OUTFEED TABLES

Hold-Down Roller

5

9	BUMPER, GRENE 70 3201 0010. SHR RUBBER	094969	1	
10	BOLT, M8 X 75 8.8 HEX HEAD ZINC	F81002-91	2	
11	WASHER, 8.4 FLAT ZINC	F81054-1	4	
12	BUSHING, FI 25X16.5X60 SPACER ZINC-PLATED	098610-1	1	
13	NUT, M8-8-B HEX NYLON LOCK ZINC	F81032-2	2	
14	BOLT, M16X100-8.8 HEX HEAD FULL THREAD ZINC	F81006-2	1	
15	WASHER, 17 FLAT ZINC	F81058-1	2	
16	NUT, M16-8 HEX NYLON ZINC LOCK	F81036-2	1	
	WHEEL, HOLD-DOWN COMPLETE	502639	1	
17	WHEEL, HOLD-DOWN ZINC-PLATED	502638-1	1	
18	BUSHING, ϕ 20.5x ϕ 30x18 SPACER	502645-1	2	
19	BEARING, 6005 2RS CX	089652	2	
20	RING, W47 INSIDE RETAINING	089653	2	
	SPRING, 340N GAS COMPLETE	089212	1	
21	Spring, Gas	089205	1	
22	Bolt, M8	089206	2	
23	MOUNT WELDMENT, HOLD-DOWN ROLLER	510306-1	1	
24	BOLT, M12x115-8.8-HEX HEAD ZINC	F81004-33	1	
25	WASHER, 13 FLAT ZINC	F81056-1	2	
26	NUT,M12-8 HEX NYLON ZINC LOCK	F81034-2	1	
27	BOLT, ADJUSTMENT	505006	1	
28	NUT, M16-5-B HEX	F81036-5	1	
29	BOLT, M10x125-8.8 HEX HEAD ZINC	F81003-18	4	
30	WASHER,10.2 SPLIT LOCK ZINC	F81055-2	4	
31	WASHER, 10.5 FLAT ZINC	F81055-1	4	
32	PLATE WELDMENT, UPPER MOUNTING	503435-1	1	
33	BOLT, M10x115-8.8 HEX HEAD ZINC	100757-1	2	
34	BOLT, M8 X 65 8.8 HEX HEAD FULL THREAD ZINC	F81002-9	8	
35	NUT, M8-8-B HEX ZINC	F81032-1	8	

5.4 TVS SC 2.4 & TVSSC 3.6 Outfeed Table

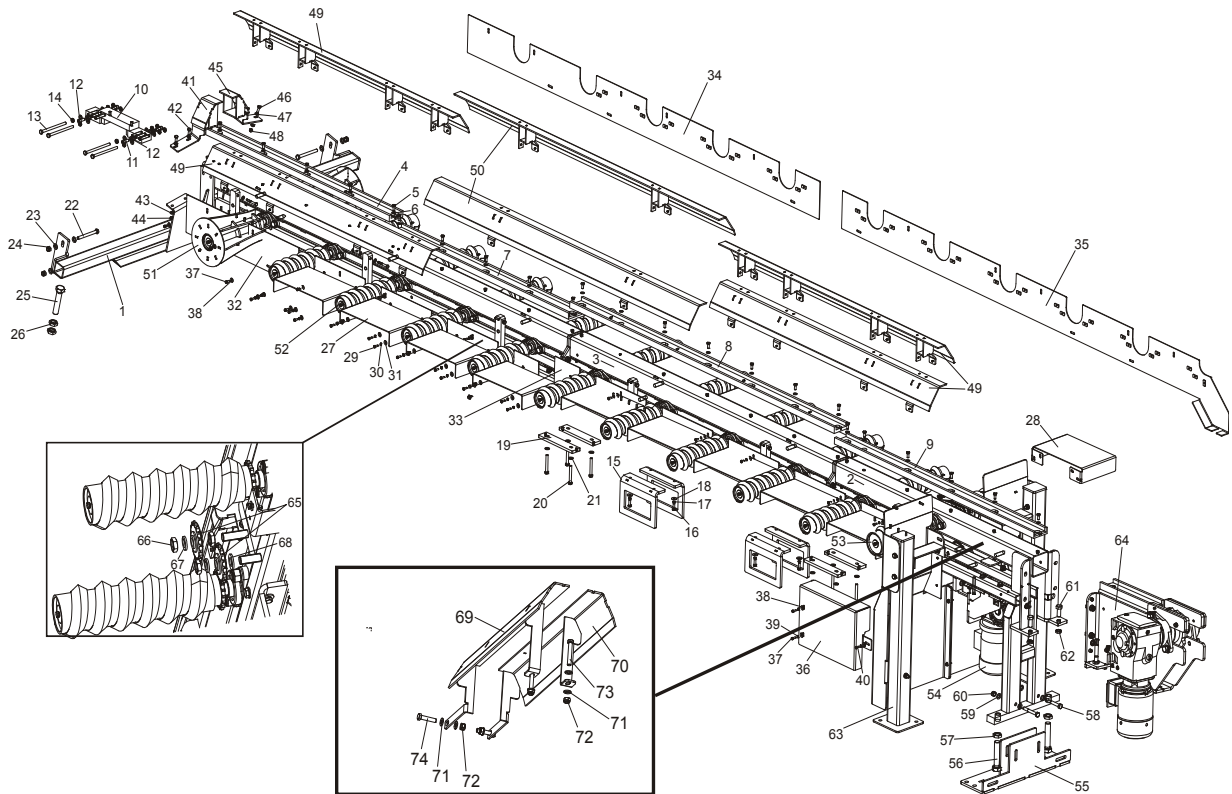

REF.	DESCRIPTION (◆ Indicates Parts Available In Assemblies Only)	PART #	QTY. TVSOS 3.6	QTY. TVSOS 2.4
	TABLE, TVSOS 2.4 OUTFEED	509215	-	1
	TABLE, TVSOS 3.6 OUTFEED	509200	1	-
	TABLE, TVSSC 2.4E OUTFEED	511330	-	1
	TABLE, TVSSC 3.6E OUTFEED	511335	1	-
1	SECTION, OUTFEED TABLE LONG	509214-1	1	1
2	SECTION, OUTFEED TABLE SHORT WELDED	509213-1	1	1
3	EXTENSION, OUTFEED TABLE	509220-1	1	0
4	CHANNEL, CHAIN FRONT GUIDE	509342	1	1
5	BOLT, M8x20-5.8 HEX HEAD FULL THREAD ZINC	F81002-1	24	16
6	WASHER, 8.4 FLAT ZINC	F81054-1	24	16
7	CHANNEL, CHAIN GUIDE	502562	1	1
8	CHANNEL, CHAIN GUIDE	509344	1	0
9	CHANNEL, CHAIN GUIDE	509341	1	1
10	LINK, COMPLETE	508177-1	1	1
11	SCREW, M10x25 8.8 HEX SOCKET SET CAP ZINC	F81003-32	4	4
12	WASHER, 10.5 FLAT ZINC	F81055-1	16	16
13	BOLT, M10x150-8.8-HEX HEAD ZINC	F81003-54	4	4
14	NUT, M10-04-W HEX THIN ZINC	F81033-6	12	12
	TRANSPORT BRACKET ASSEMBLY, TVS SC 3.6	509770	1	See Section 5.11

TVS-SC INFEED & OUTFEED TABLES

TVS SC 2.4 & TVSSC 3.6 Outfeed Table

5

15	BRACKET, TVS SC OUTFEED TABLE TRANSPORT	509769-1	4	-
16	BOLT, M8X30-5.8 HEX HEAD FULL THREAD ZINC	F81002-2	8	-
17	WASHER, 8.2 SPLIT LOCK ZINC	F81054-4	8	-
18	WASHER, 8.5 SPECIAL FLAT ZINC	F81054-11	8	-
19	PLATE, CONNECTING	509516-1	4	See Section 5.11
20	BOLT, M10x80-8.8 HEX HEAD ZINC	F81003-50	8	See Section 5.11
21	WASHER, 10.5 FLAT ZINC	F81055-1	8	See Section 5.11
22	BOLT, M12x115-8.8-HEX HEAD ZINC	F81004-33	4	4
23	WASHER, 13 FLAT ZINC	F81056-1	8	8
24	NUT, M12-8 HEX NYLON ZINC LOCK	F81034-2	4	4
25	BOLT, M24X120 8.8 HEX HEAD FULL THREAD ZINC	F81009-6	2	2
26	NUT, M24-04-B-HEX THIN ZINC	F81039-3	4	4
	FILLER PLATE ASSEMBLY	509202	1	0
	FILLER PLATE ASSEMBLY	507834	0	1
27	PLATE, LEFT FILLER	507837-1	9	5
28	PLATE, RIGHT FILLER RIGHT	507836-1	9	5
29	BOLT, M6x16 8.8 HEX HEAD FULL THREAD ZINC	F81001-15	72	40
30	WASHER, Z6.1 SPLIT LOCK ZINC	F81053-3	72	40
31	WASHER, 6.5 SPECIAL FLAT ZINC	F81053-11	72	40
	SIDE GUARD SET	509201	1	0
	SIDE GUARD SET - COMPLETE	507835	0	1
32	GUARD WELDMENT, LEFT FRONT	509192-1	1	0
32	GUARD WELDMENT, LEFT FRONT	508036-1	0	1
33	GUARD WELDMENT, LEFT MIDDLE	509188-1	1	0
33	GUARD WELDMENT, LEFT MIDDLE	508037-1	0	1
34	GUARD, RIGHT FRONT	509194-1	1	0
35	GUARD WELDMENT, RIGHT MIDDLE	509190-1	1	0
35	GUARD WELDMENT, RIGHT MIDDLE	508023-1	0	1
36	GUARD, LEFT END	508755-1	1	1
37	BOLT, M6x16 8.8 HEX HEAD FULL THREAD ZINC	F81001-15	14	11
38	WASHER, 6.5 SPECIAL FLAT ZINC	F81053-11	35	27
39	WASHER, Z6.1 SPLIT LOCK ZINC	F81053-3	35	27
40	BOLT, M6x12-8.8 HEX HEAD FULL THREAD ZINC	F81001-7	21	16
	GUARD SET, 3.6 TABLE UPPER	510935	1	0
	GUARD SET, 2.4 TABLE UPPER	510920	0	1
	GUARD, COMPLETE RIGHT	510925	1	1
41	GUARD WELDMENT, UPPER	510923-1	1	1
42	BOLT, M8X25-8.8-B HEX HEAD FULL THREAD ZINC	F81002-5	2	2
43	WASHER, 8.4 FLAT ZINC	F81054-1	4	4
44	NUT, M8-8-B HEX NYLON ZINC LOCK	F81032-2	2	2
	GUARD, COMPLETE LEFT	509915	1	1
45	GUARD, LEFT	509916-1	1	1
46	BOLT, M8X25-8.8-B HEX HEAD FULL THREAD ZINC	F81002-5	2	2

47	WASHER, 8.4 FLAT ZINC	F81054-1	4	4
48	NUT, M8-8-B HEX NYLON ZINC LOCK	F81032-2	2	2
49	GUARD WELDMENT, UPPER	510930-1	4	4
50	GUARD WELDMENT, MIDDLE UPPER	510932-1	2	0
51	ROLLER ASSEMBLY, SIDE FRONT SEE SECTION 5.5	508035 ¹	1	1
52	ROLLER ASSEMBLY, ϕ 100 SIDE SPIRAL SEE SECTION 5.6	507440 ¹	9	5
53	ROLLER ASSEMBLY, 131 SIDE SPIRAL SEE SECTION 5.7	507441 ¹	1	1
54	DRIVE ASSEMBLY, TVS SC OUTFEED TABLE SIDE ROLLER SEE SECTION 5.8	508200 ¹	1	1
55	FOOT WELDMENT, TVS TABLE	502750-1	1	1
56	BOLT, M24X120 8.8 HEX HEAD FULL THREAD ZINC	F81009-6	2	2
57	NUT, M24-04-B-HEX THIN ZINC	F81039-3	2	2
58	BOLT, M12X90-8.8 HEX HEAD ZINC	F81004-2	2	2
59	WASHER, 13 FLAT ZINC	F81056-1	4	4
60	NUT, M12-8 HEX NYLON ZINC LOCK	F81034-2	2	2
61	BOLT, M16X40-8.8 HEX HEAD FULL THREAD ZINC	F81006-13	2	2
62	NUT, M16 HEX THIN ZINC	F81036-4	2	2
63	STOP PLATE SET SEE SECTION 5.9	508930 ¹	1	1
64	DRIVE ASSEMBLY, MAIN CHAIN SEE SECTION 5.10	508005	1	1
65	SPROCKET, Z=18 KSR16.L0.08.10.18.0	088700	13	8
66	NUT, M16 8 HEX THIN ZINC	F81036-4	16	12
67	WASHER, 16.3 SPLIT LOCK ZINC	F81058-2	10	6
68	WASHER, 17 FLAT ZINC	F81058-1	3	3
	END GUARD ASSEMBLY	511342²	1	1
69	GUARD, RIGHT END	511340-1	1	1
70	GUARD, LEFT END	511341-1	1	1
71	WASHER, 13MM DIA. BORE	F81056-1	8	8
72	NUT, M12-8 HEX NYLON ZINC LOCK	F81034-2	4	4
73	BOLT, M12X75-8.8 HEX HEAD ZINC	F81004-21	2	2
74	BOLT, M12x55-8.8 HEX HEAD ZINC	F81004-12	2	2

¹ Not included in TVSSC E version (Economic).

² Belongs to 511330 and 511335.

5.5 Side Front Rollers

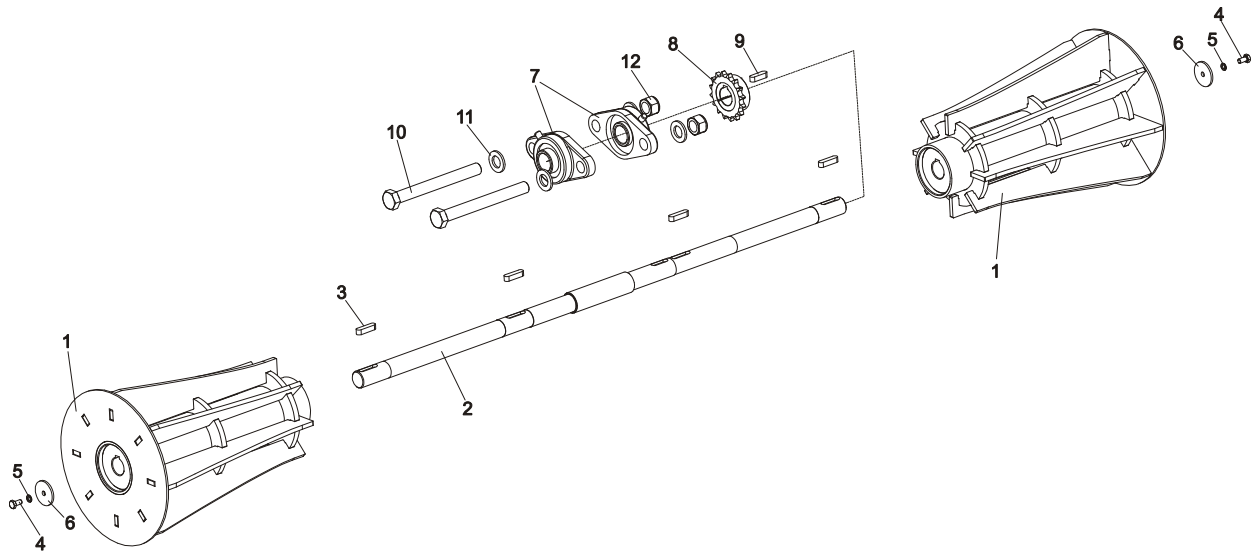

REF.	DESCRIPTION (◆ Indicates Parts Available In Assemblies Only)	PART #	QTY.
	ROLLER ASSEMBLY, SIDE FRONT	508035	1
1	ROLLER, SIDE FRONT	508032-1	2
2	SHAFT, SIDE ROLLER	507031	1
3	KEY, A8x7x32 PARALLEL	088564	4
4	BOLT, M6x12-8.8 HEX HEAD FULL THREAD ZINC	F81001-7	2
5	WASHER, Z6.1 SPLIT LOCK ZINC	F81053-3	2
6	WASHER, ZINC-PLATED	507033-1	2
7	BEARING, UCFL 205 CX W/HOUSING	089124	2
8	SPROCKET, 16Z 08B/25(T64990+T31026) ZINC-PLATED	508042	1
9	KEY, A 8x7x28 PARALLEL	096035	1
10	BOLT, M16x150-8.8-HEX HEAD ZINC	F81006-9	2
11	WASHER, 17 FLAT ZINC	F81058-1	4
12	NUT, M16-8 HEX NYLON ZINC LOCK	F81036-2	2

5.6 ϕ 100 Side Spiral Rollers

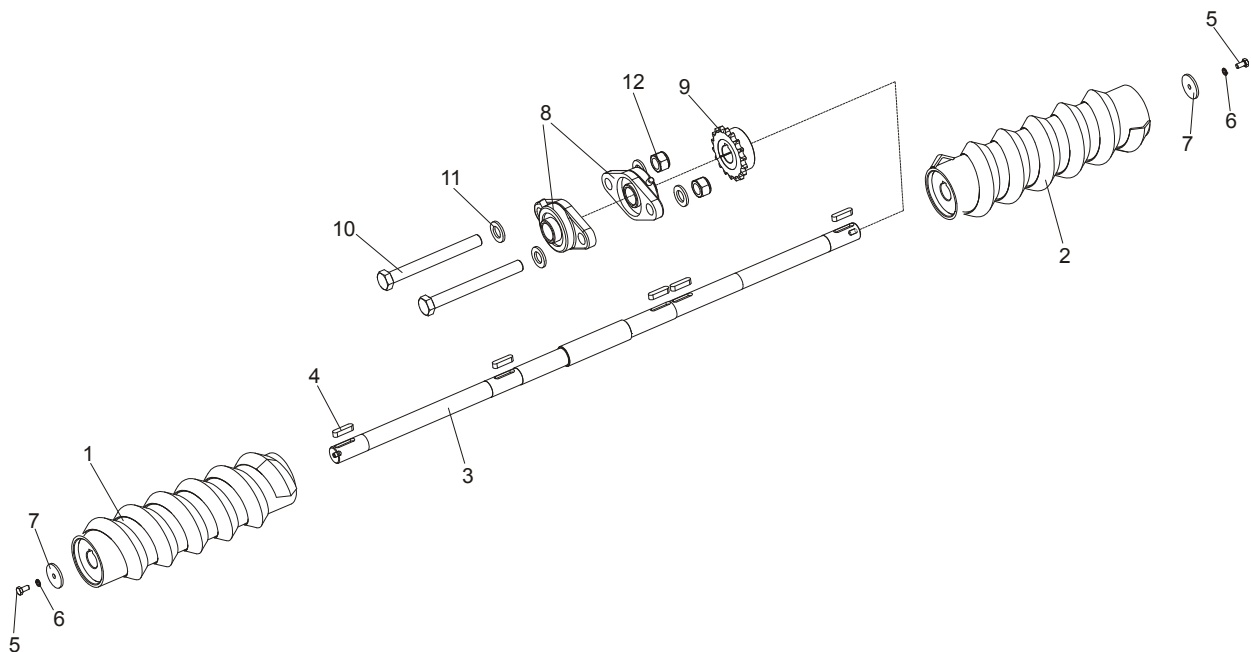

REF.	DESCRIPTION (◆ Indicates Parts Available In Assemblies Only)	PART #	QTY.
	ROLLER ASSEMBLY, Ø100 SIDE SPIRAL	507440	9
1	ROLLER, SIDE SPIRAL RIGHT-HANDED	507020-1	1
2	ROLLER, SIDE SPIRAL LEFT-HANDED	507021-1	1
3	SHAFT, SIDE ROLLER	507031	1
4	KEY, A8x7x32 PARALLEL	088564	5
5	BOLT, M6x12-8.8 HEX HEAD FULL THREAD ZINC	F81001-7	2
6	WASHER, Z6.1 SPLIT LOCK ZINC	F81053-3	2
7	WASHER, ZINC-PLATED	507033-1	2
8	BEARING, UCFL 205 CX W/HOUSING	089124	2
9	SPROCKET, Z=18 08BZ TAPER.FI 25 T64991	099671	1
10	BOLT, M16x150-8.8-HEX HEAD ZINC	F81006-9	2
11	WASHER, 17 FLAT ZINC	F81058-1	4
12	NUT, M16-8 HEX NYLON ZINC LOCK	F81036-2	2
	CHAIN, SPIRAL ROLLER DRIVE (531 LINKSM, SC2.4)	507498	1
	CHAIN, SPIRAL ROLLER DRIVE (807 LINKSM, SC3.6)	509203	1

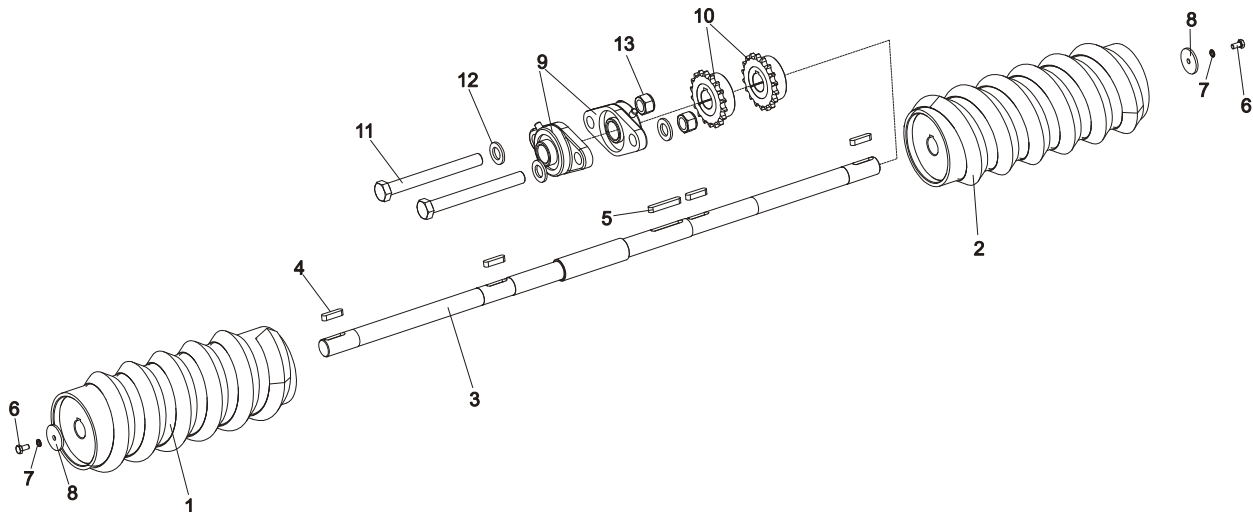
5.7 ϕ 130 Side Spiral Rollers

REF.	DESCRIPTION (◆ Indicates Parts Available In Assemblies Only)	PART #	QTY.	
	ROLLER ASSEMBLY, 131 SIDE SPIRAL	507441	1	
1	ROLLER, LARGE SPIRAL LEFT-HANDED	507040-1	1	
2	ROLLER, LARGE SPIRAL RIGHT-HANDED	507036-1	1	
3	SHAFT, LARGE SIDE ROLLER	509354	1	
4	KEY, A8x7x32 PARALLEL	088564	4	
5	KEY, A8X7X50 PARALLEL	088563	1	
6	BOLT, M6x12-8.8 HEX HEAD FULL THREAD ZINC	F81001-7	2	
7	WASHER, Z6.1 SPLIT LOCK ZINC	F81053-3	2	
8	WASHER, ZINC-PLATED	507033-1	2	
9	BEARING, UCFL 205 CX W/HOUSING	089124	2	
10	SPROCKET, Z=18, 08BZ TAPER.FI 25 T64991	099671	2	
11	BOLT, M16x150-8.8 HEX HEAD ZINC	F81006-9	2	
12	WASHER, 17 FLAT ZINC	F81058-1	4	
13	NUT, M16-8 HEX NYLON ZINC LOCK	F81036-2	2	

5.8 Drive Assembly, TVS SC Outfeed Table Side Roller

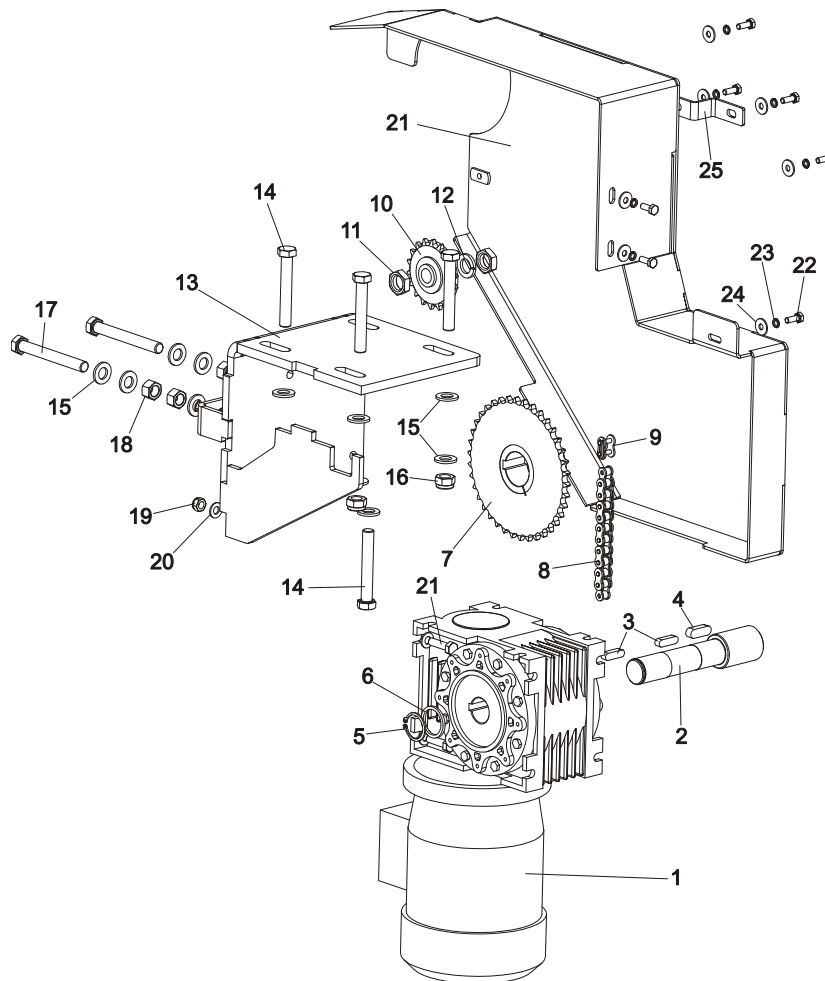

REF.	DESCRIPTION (◆ Indicates Parts Available In Assemblies Only)	PART #	QTY.
	DRIVE ASSEMBLY, TVS SC OUTFEED TABLE SIDE ROLLER	508200	1
	DRIVE ASSEMBLY, TVS SC UL STANDARD OUTFEED TABLE SIDE ROLLER	508200-UL	1
1	MOTOREDUCER, MR-63/49/0.55-1400/F3/N+S/V6	505080	1
	Motor, Skh 80-4A/3045 .55kW 1400 r.p.m.	083794	1
	MOTOREDUCER, MR-63/49/0.55-1400/F3/N+S/V6 UL STANDARD	505080	1
2	SHAFT	508201	1
3	KEY, A 8x7x28 PARALLEL	096035	2
4	KEY, A10X8X30 PARALLEL	507012	1
5	RING, Z28 OUTSIDE RETAINING	F81090-12	1
6	WASHER, ZINC-PLATED	508198-1	1
7	SPROCKET, 38Z 08B/38(T43987+T31109) ZINC-PLATED	507030	1
8	CHAIN, 0.08B-1 L=1358.9 ROLLER DRIVE (107-LINK)	508210	1
9	LINK, 08B-1PZ CHAIN	090712	1
10	SPROCKET, Z18 1/2"x5/16" W/BEARING	088700	1
11	NUT, M16 8 HEX THIN ZINC	F81036-4	2
12	WASHER, 16.3 SPLIT LOCK ZINC	F81058-2	1
13	BRACKET WELDMENT, GEAR BOX MOUNT	508205-1	1

TVS-SC INFEED & OUTFEED TABLES

Drive Assembly, TVS SC Outfeed Table Side Roller

5

14	BOLT, M12X80-8.8 HEX HEAD ZINC	F81004-46	4	
15	WASHER, 13 FLAT ZINC	F81056-1	14	
16	NUT, M12-8 HEX NYLON ZINC LOCK	F81034-2	4	
17	BOLT, M12X100 8.8 HEX HEAD FULL THREAD ZINC	F81004-45	2	
18	NUT, M12-8-B HEX ZINC	F81034-1	4	
19	NUT, M8-8-B HEX NYLON ZINC LOCK	F81032-2	4	
20	WASHER, 8.4 FLAT ZINC	F81054-1	8	
21	BOLT, M8x30-5.8 HEX HEAD FULL THREAD ZINC	F81002-2	4	

5.9 Slab Stop Plates

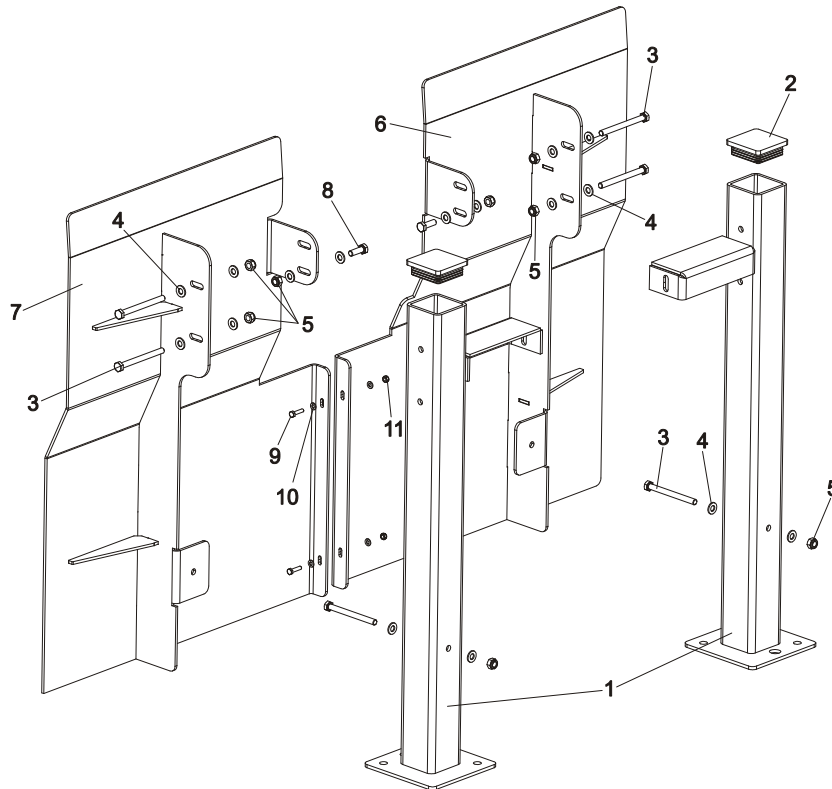

REF.	DESCRIPTION (◆ Indicates Parts Available In Assemblies Only)	PART #	QTY.
	STOP PLATE SET	508930	1
1	LEG WELDMENT, STOP PLATE SUPPORT	508931-1	2
2	FRAME CAP	089644	2
3	BOLT, M10x110 8.8 HEX HEAD ZINC	F81003-43	6
4	WASHER, 10.5 FLAT ZINC	F81055-1	16
5	NUT, M10-8-B HEX NYLON ZINC LOCK	F81033-1	8
6	PLATE WELDMENT, LEFT STOP	509801-1	1
7	PLATE WELDMENT, RIGHT STOP	509798-1	1
8	BOLT, M10X30-5.8 HEX HEAD FULL THREAD ZINC	F81003-2	2
9	BOLT, M6X25-5.8 HEX HEAD FULL THREAD ZINC	F81001-3	2
10	WASHER, 6.4 FLAT ZINC	F81053-1	4
11	NUT, M6-8-B HEX NYLON ZINC LOCK	F81031-2	2

5.10 TVS-SC Chain Drive Assembly

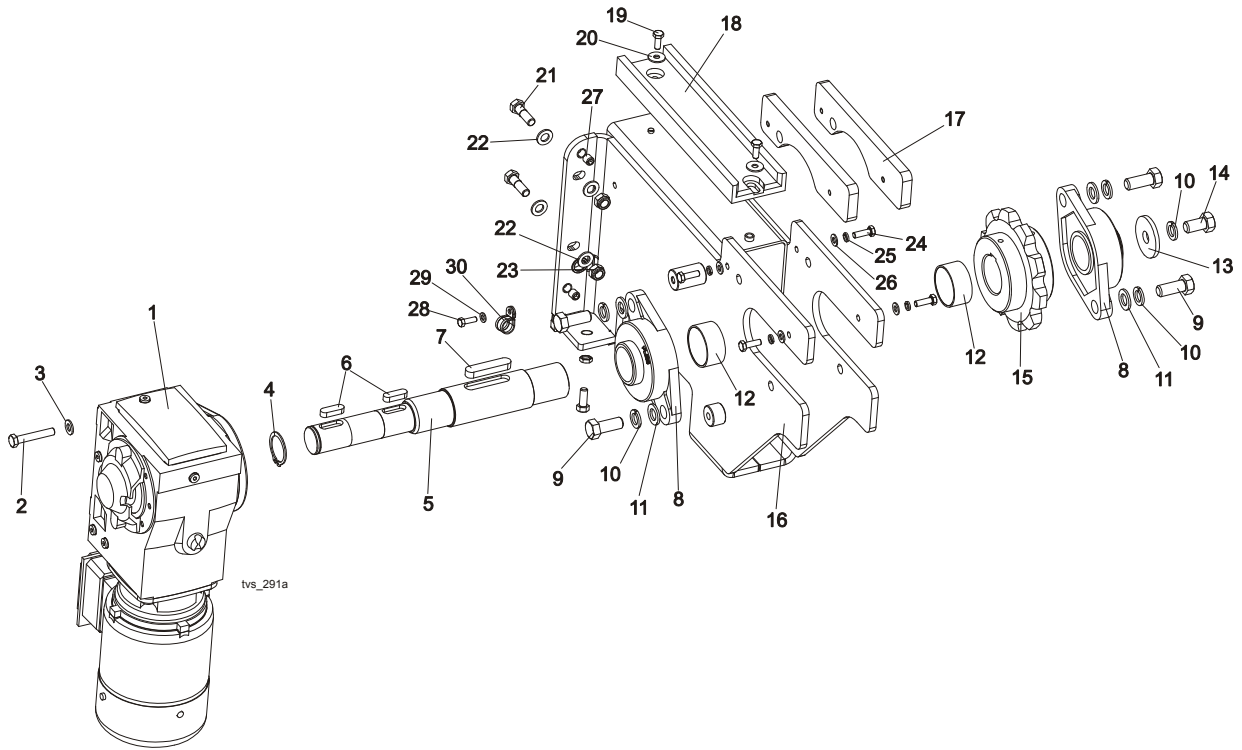

REF.	DESCRIPTION (◆ Indicates Parts Available In Assemblies Only)	PART #	QTY.
	DRIVE ASSEMBLY, TVS-SC MAIN CHAIN	508005	1
	DRIVE ASSEMBLY, TVS SC (NORD) CHAIN	510060	1
1	MOTOREDUCER, SK9016.IAZ 0,75KW I=64	509819	1
	Box, SK9016.1AZBDH 200969672 Gear ¹	510911	1
	Motor, 80LH/4TF 200969672	510912	1
2	BOLT, M10x60-8.8 HEX HEAD ZINC	F81003-10	1
3	WASHER, 10.5 FLAT ZINC	F81055-1	1
4	RING, Z40 OUTSIDE RETAINING	F81090-33	1
5	SHAFT, SK9016 (NORD) MOTOREDUCER DRIVE	510059	1
6	KEY, A12X8X36 PARALLEL	503182	2
7	KEY, A16X10X70 PARALLEL	098029	1
8	BEARING, UCFL 210 CX W/HOUSING	098824	2
9	BOLT, M16x40-8.8 HEX HEAD FULL THREAD ZINC	F81006-13	4
10	WASHER, 16.3 SPLIT LOCK ZINC	F81058-2	5
11	WASHER, 17 FLAT ZINC	F81058-1	4
12	BUSHING, FI60X55.5X27 SPACER	507499-1	2
13	WASHER, ZINC-PLATED LOCKING	098012-1	1
14	BOLT, M16X30 8.8 HEX HEAD FULL THREAD ZINC	F81006-36	1
15	SPROCKET, 10Z 20B/2" 55 DIA.	502565-1	1
16	MODULE WELDMENT, DRIVE	508215-1	1
17	PLATE	508899-1	2
18	CHANNEL, CHAIN GUIDE	508008	1
19	BOLT, M8x20-5.8 HEX HEAD FULL THREAD ZINC	F81002-1	2

20	WASHER, 8.5 SPECIAL FLAT ZINC	F81054-11	2	
21	BOLT, M12X40-8.8 HEX HEAD ZINC	F81004-1	4	
22	WASHER, 13 FLAT ZINC	F81056-1	8	
23	NUT, M12-8 HEX NYLON ZINC LOCK	F81034-2	4	
24	BOLT, M8X25-8.8-B HEX HEAD FULL THREAD ZINC	F81002-5	4	
25	WASHER, 8.2 SPLIT LOCK ZINC	F81054-4	4	
26	WASHER, 8.4 FLAT ZINC	F81054-1	4	
27	SCREW, M12x12-33H HEX SOCKET SET FLAT POINT	F81004-15	2	
28	BOLT, M5x16-5.8 HEX HEAD FULL THREAD ZINC	F81000-51	1	
29	WASHER, 5.3 FLAT ZINC	F81052-1	1	
30	CLIP, RSGU 1.10/12 W1 RETAINING	086861	1	

¹ A new gear-box should be filled with two litres of ISO VG220 mineral oil.

5.11 TVS SC 2.4 Table Transport Brackets

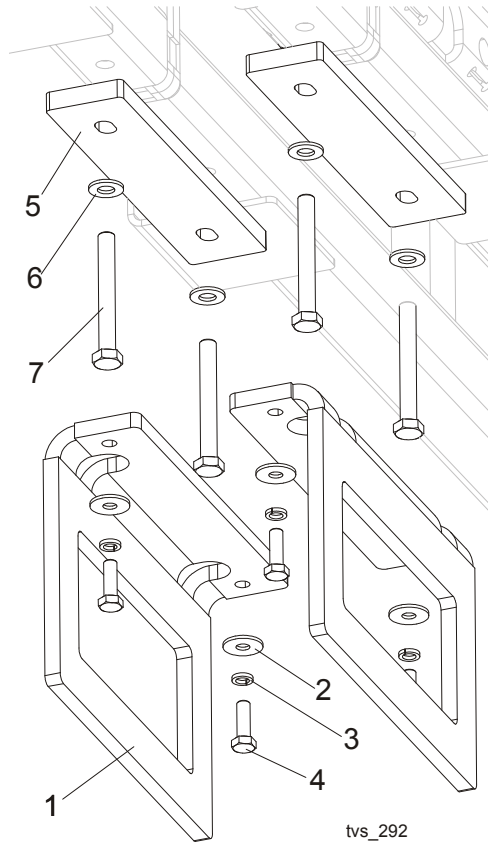

REF.	DESCRIPTION (◆ Indicates Parts Available In Assemblies Only)	PART#	QTY.
	BRACKET, TVS SC 2.4 TRANSPORT - COMPLETE	509517	4
1	BRACKET, OUTFEED TABLE TRANSPORT	508918-1	1
2	WASHER, 8.5 SPECIAL FLAT ZINC	F81054-11	2
3	WASHER, 8.2 SPLIT LOCK ZINC	F81054-4	2
4	BOLT, M8x25-8.8-B HEX HEAD FULL THREAD ZINC	F81002-5	2
5	PLATE, CONNECTING	509516-1 ¹	4
6	WASHER, 10.5 FLAT ZINC	F81055-1 ¹	2
7	BOLT, M10 X 80-8.8 HEX HEAD ZINC	F81003-50 1	8

¹ Included in assembly #509497 ([See Section 5.3](#)).

5.12 Outfeed Table Hold-Down Rollers (2.4)

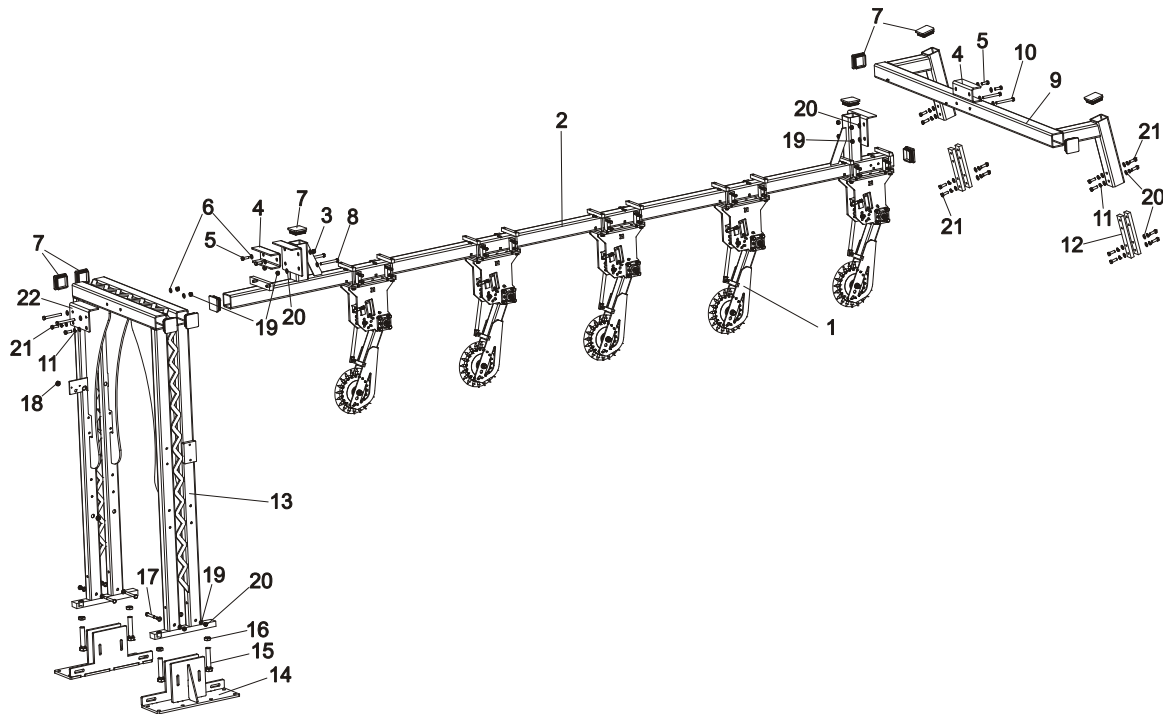

REF.	DESCRIPTION (◆ Indicates Parts Available In Assemblies Only)	PART #	QTY.
	HOLD-DOWN ROLLER SET, TVSOS3.6 OUTFEED TABLE	510940	1
1	ROLLER, HOLD-DOWN COMPLETE See Section 5.3	510308	5
	TUBE, TVS 3.6 HOLD-DOWN ROLLER MIDDLE MOUNT - COMPLETE	510944	1
2	TUBE, TVS 3.6 HOLD-DOWN ROLLER MIDDLE MOUNT	510943-1	1
3	NUT, M12-8 HEX NYLON ZINC LOCK	F81034-2	4
4	CHANNEL, SPACER	510082-1	2
5	BOLT, M12X35-8.8 HEX HEAD FULL THREAD ZINC	F81004-24	4
6	WASHER, 13 FLAT ZINC	F81056-1	8
7	CAP, FRAME TUBE	089644	12
8	BOLT, M12x110-8.8-B HEX HEAD ZINC	F81004-47	6
9	TUBE WELDMENT, HOLD-DOWN ROLLER REAR MOUNT	100731-1	1
10	BOLT, M12x110-8.8-B-HEX HEAD ZINC	F81004-47	6
11	WASHER, Z12.2 SPLIT LOCK ZINC	F81056-2	18
12	BAR, TVS MOUNTING ZINC-PLATED	100756-1	4
13	FRAME WLDMT, HOLD-DOWN ROLLER FRONT MOUNT	510300-1	1
14	FOOT WELDMENT, TVSSC	510315-1	2
15	BOLT, M24X120 8.8 HEX HEAD FULL THREAD ZINC	F81009-6	4
16	NUT, M24-04-B HEX THIN ZINC	F81039-3	4
17	BOLT, M12 X 100-8.8 HEX HEAD ZINC	F81004-3	4
18	GROMMET, 20/13 RUBBER	086188	2
19	WASHER, 13 FLAT ZINC	F81056-1	38
20	NUT, M12-8 HEX NYLON ZINC LOCK	F81034-2	10
21	BOLT, M12X35-8.8 HEX HEAD FULL THREAD ZINC	F81004-24	18
22	ANGLE	510310-1	1

5.13 Outfeed Table Hold-Down Rollers (2.4E)

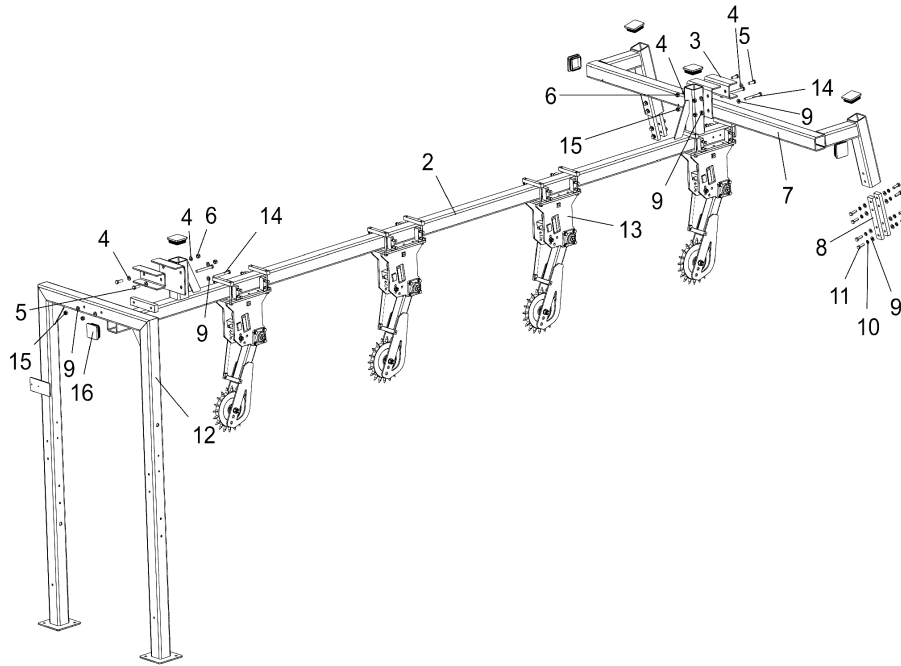

REF.	DESCRIPTION (◆ Indicates Parts Available In Assemblies Only)	PART #	QTY.
	HOLD-DOWN ROLLER SET, TVSSC2.4E OUTFEED TABLE	511132	1
1	TUBE, TVS SC 2.4 HOLD-DOWN ROLLER MIDDLE MOUNT - COMPLETE	510944	1
2	TUBE, TVS SC 2.4 HOLD-DOWN ROLLER MIDDLE MOUNT	510943-1	1
3	CHANNEL, SPACER	510082-1	2
4	WASHER, 13 FLAT ZINC	F81056-1	8
5	BOLT, M12 X 35-8.8 HEX HEAD FULL THREAD ZINC	F81004-24	4
6	NUT, M12-8 HEX NYLON ZINC LOCK	F81034-2	4
7	TUBE WELDMENT, HOLD-DOWN ROLLER REAR MOUNT	100731-1	1
8	BAR, TVS MOUNTING ZINC-PLATED	100756-1	4
9	WASHER, 13 FLAT ZINC	F81056-1	24
10	WASHER, Z12.2 SPLIT LOCK ZINC	F81056-2	16
11	BOLT, M12 X 35-8.8 HEX HEAD FULL THREAD ZINC	F81004-24	16
12	FRAME WLDMT, HOLD-DOWN ROLLER FRONT MOUNT	507525-1	1
13	ROLLER, HOLD-DOWN COMPLETE See Section 5.3	510308	4
14	BOLT, M12x110-8.8-B-HEX HEAD ZINC	F81004-47	4
15	NUT, M12-8 HEX NYLON ZINC LOCK	F81034-2	4
16	CAP, FRAME TUBE	089644	8

5.14 Outfeed Table Hold-Down Rollers (3.6)

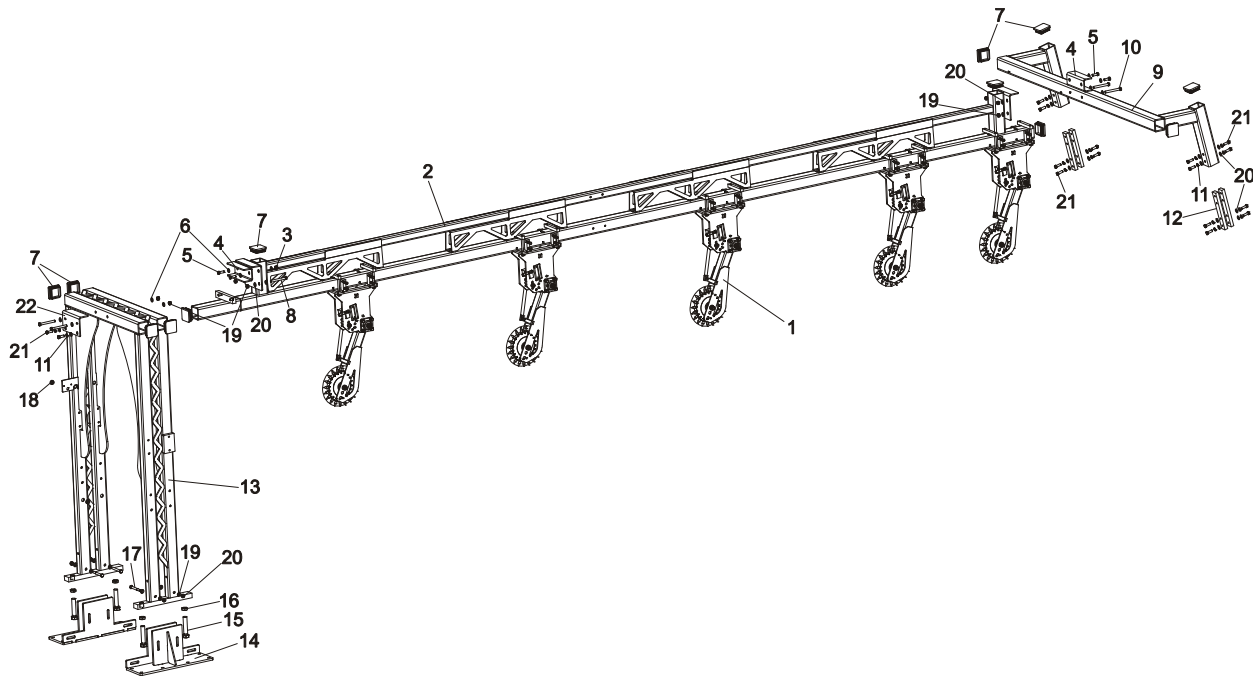

REF.	DESCRIPTION (◆ Indicates Parts Available In Assemblies Only)	PART #	QTY.
	HOLD-DOWN ROLLER SET, TVSOS3.6	510945	1
1	ROLLER, HOLD-DOWN COMPLETE See Section 5.3	510308	5
	BEAM, TVS 3.6 HOLD-DOWN ROLLER MIDDLE MOUNT - COMPLETE	510364	1
2	BEAM, TVS 3.6 HOLD-DOWN ROLLER MIDDLE MOUNT	510361-1	1
3	NUT, M12-8 HEX NYLON ZINC LOCK	F81034-2	4
4	CHANNEL, SPACER	510082-1	2
5	BOLT, M12X35-8.8 HEX HEAD FULL THREAD ZINC	F81004-24	4
6	WASHER, 13 FLAT ZINC	F81056-1	8
7	CAP, FRAME TUBE	089644	12
8	BOLT, M12x110-8.8-B HEX HEAD ZINC	F81004-47	6
9	TUBE WELDMENT, HOLD-DOWN ROLLER REAR MOUNT	100731-1	1
10	BOLT, M12x110-8.8-B HEX HEAD ZINC	F81004-47	6
11	WASHER, Z12.2 SPLIT LOCK ZINC	F81056-2	18
12	BAR, TVS MOUNTING ZINC-PLATED	100756-1	4
13	FRAME WLDMT, HOLD-DOWN ROLLER FRONT MOUNT	510300-1	1
14	FOOT WELDMENT, TVSSC	510315-1	2
15	BOLT, M24X120 8.8 HEX HEAD FULL THREAD ZINC	F81009-6	4
16	NUT, M24-04-B HEX THIN ZINC	F81039-3	4
17	BOLT, M12 X 100-8.8 HEX HEAD ZINC	F81004-3	4
18	GROMMET, 20/13 RUBBER	086188	2
19	WASHER, 13 FLAT ZINC	F81056-1	38
20	NUT, M12-8 HEX NYLON ZINC LOCK	F81034-2	10
21	BOLT, M12X35-8.8 HEX HEAD FULL THREAD ZINC	F81004-24	18
22	ANGLE	510310-1	1

5.15 Outfeed Table Hold-Down Rollers (3.6E)

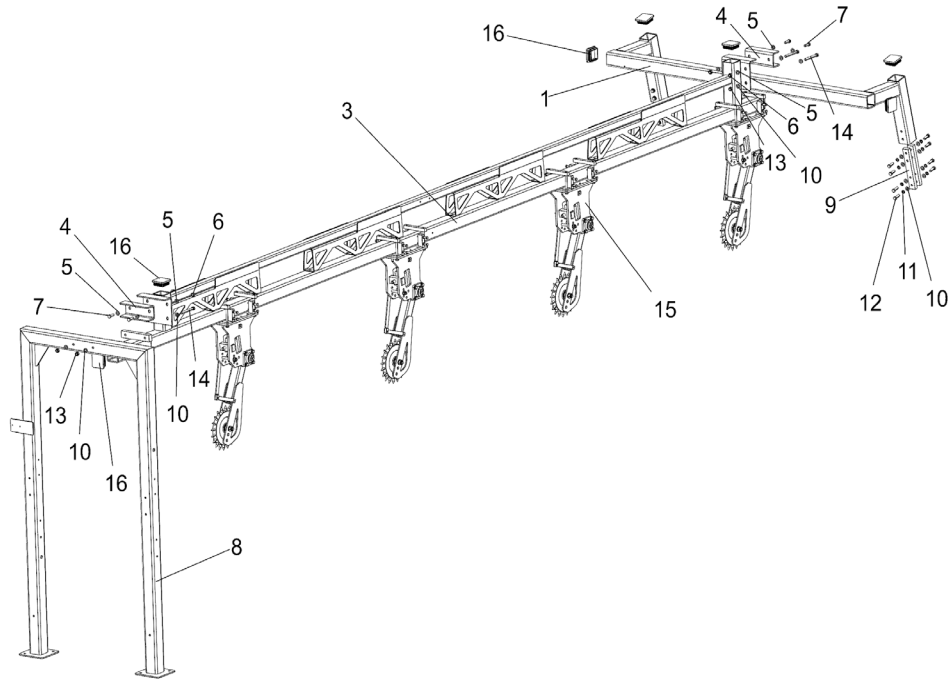

REF.	DESCRIPTION (◆ Indicates Parts Available In Assemblies Only)	PART #	QTY.
	HOLD-DOWN ROLLER SET, TVSOS3.6E	511334	1
1	TUBE WELDMENT, HOLD-DOWN ROLLER REAR MOUNT	100731-1	1
2	BEAM, TVS 3.6 HOLD-DOWN ROLLER MIDDLE MOUNT - COMPLETE	510364	1
3	BEAM, TVS 3.6 HOLD-DOWN ROLLER MIDDLE MOUNT	510361-1	1
4	CHANNEL, SPACER	510082-1	2
5	WASHER, 13 FLAT ZINC	F81056-1	8
6	NUT, M12-8 HEX NYLON ZINC LOCK	F81034-2	4
7	BOLT, M12X35-8.8 HEX HEAD FULL THREAD ZINC	F81004-24	4
8	FRAME WLDMT, HOLD-DOWN ROLLER FRONT MOUNT	507525-1	1
9	BAR, TVS MOUNTING ZINC-PLATED	100756-1	4
10	WASHER, 13 FLAT ZINC	F81056-1	24
11	WASHER, Z12.2 SPLIT LOCK ZINC	F81056-2	16
12	BOLT, M12X35-8.8 HEX HEAD FULL THREAD ZINC	F81004-24	16
13	NUT, M12-8 HEX NYLON ZINC LOCK	F81034-2	16
14	BOLT, M12x110-8.8-B HEX HEAD ZINC	F81004-47	4
15	ROLLER, HOLD-DOWN COMPLETE See Section 5.3	510308	4
16	CAP, FRAME TUBE	089644	12

5.16 Barriers & Side Guards, TVS SC 2.4 (Only CE Version)

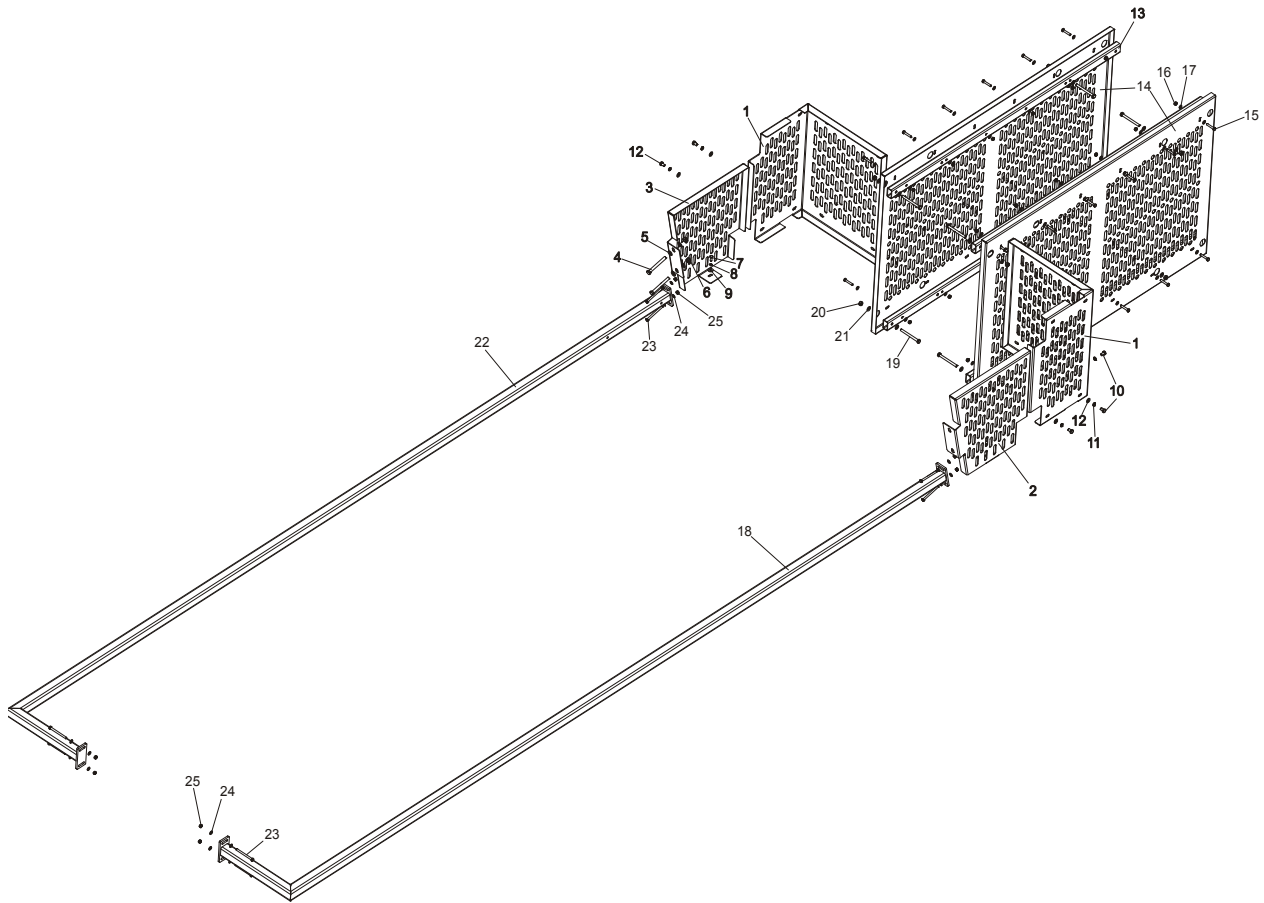

REF.	DESCRIPTION (◆ Indicates Parts Available In Assemblies Only)	PART #	QTY.
	BARRIER & SIDE GUARD SET, TVS SC 2.4	508902	1
	GUARD SET, TVS SAW HEAD	508915	1
1	GUARD, RIGHT SIDE	508912-1	2
2	GUARD, LEFT SIDE	509211-1	1
3	GUARD, RIGHT SIDE	509212-1	1
4	BOLT, M12x110-8.8-B HEX HEAD ZINC	F81004-47	2
5	WASHER, 13 FLAT ZINC	F81056-1	4
6	NUT, M12-8 HEX NYLON ZINC LOCK	F81034-2	2
7	BOLT, M8x20-5.8 HEX HEAD FULL THREAD ZINC	F81002-1	2
8	WASHER, 8.2 SPLIT LOCK ZINC	F81054-4	2
9	WASHER, 8.5 SPECIAL FLAT ZINC	F81054-11	2
10	BOLT, M10x16-8.8 HEX HEAD FULL THREAD ZINC	F81003-13	8
11	WASHER, 10.2 SPLIT LOCK ZINC	F81055-2	8
12	WASHER, 10.5 FLAT ZINC	F81055-1	8
13	TUBE, SIDE GUARD SUPPORT	503632-1	4
14	GUARD, SIDE	508901-1	2
15	BOLT, M8x45-8.8-HEX HEAD ZINC	F81002-17	24
16	NUT, M8-8-B HEX NYLON ZINC LOCK	F81032-2	32

TVS-SC INFEED & OUTFEED TABLES
Barriers & Side Guards, TVS SC 2.4 (Only CE Version)

5

17	WASHER, 8.4 FLAT ZINC	F81054-1	64	
18	BARRIER, TVS SC/FT LEFT SIDE	508907-1	1	
19	BOLT, M10x110 8.8 HEX HEAD ZINC	F81003-43	8	
20	NUT, M10-8-B HEX NYLON ZINC LOCK	F81033-1	8	
21	WASHER, 10.5 FLAT ZINC	F81055-1	16	
22	BARRIER, TVS SC/FT SIDE	508906-1	1	
23	BOLT, M8x100 -8.8 HEX HEAD ZINC	F81002-23	8	
24	WASHER, 8.4 FLAT ZINC	F81054-1	64	
25	NUT, M8-8-B HEX NYLON ZINC LOCK	F81032-2	32	

5.17 Barriers & Side Guards, TVS SC 3.6 (Only CE Version)

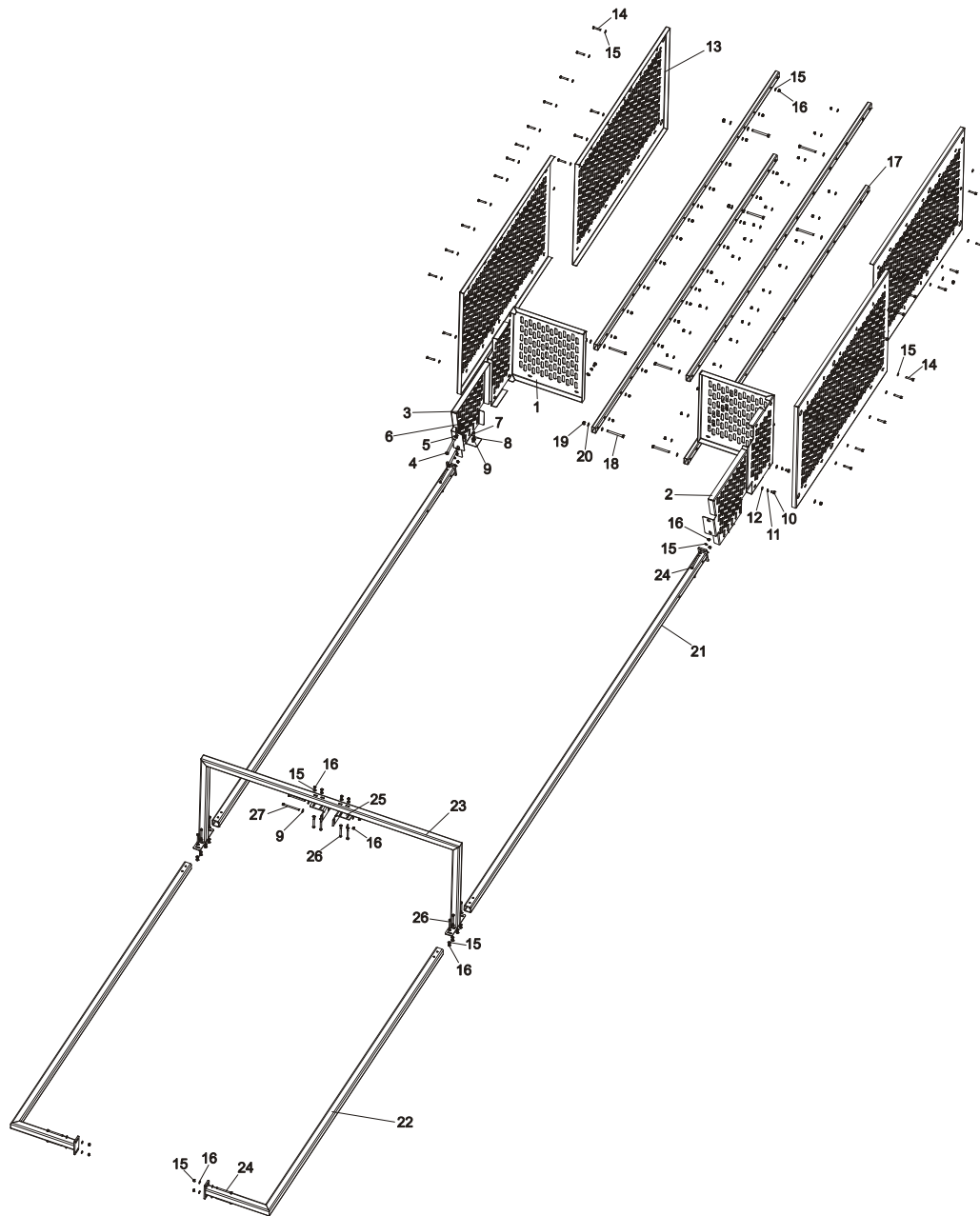

REF.	DESCRIPTION (◆ Indicates Parts Available In Assemblies Only)	PART #	QTY.
	BARRIER & SIDE GUARD SET, TVS SC 2.4	509355	1
	GUARD SET, TVS SAW HEAD	508915	1
1	GUARD, RIGHT SIDE	508912-1	2
2	GUARD, LEFT SIDE	509211-1	1
3	GUARD, RIGHT SIDE	509212-1	1
4	BOLT, M12x110-8.8-B HEX HEAD ZINC	F81004-47	2
5	WASHER, 13 FLAT ZINC	F81056-1	4
6	NUT, M12-8 HEX NYLON ZINC LOCK	F81034-2	2
7	BOLT, M8x20-5.8 HEX HEAD FULL THREAD ZINC	F81002-1	2

TVS-SC INFEED & OUTFEED TABLES
Barriers & Side Guards, TVS SC 3.6 (Only CE Version)

5

8	WASHER, 8,2 SPLIT LOCK ZINC	F81054-4	2	
9	WASHER, 8.5 SPECIAL FLAT ZINC	F81054-11	2	
10	BOLT, M10x16-8.8 HEX HEAD FULL THREAD ZINC	F81003-13	8	
11	WASHER, 10.2 SPLIT LOCK ZINC	F81055-2	8	
12	WASHER, 10.5 FLAT ZINC	F81055-1	8	
13	GUARD, SIDE	509356-1	4	
14	BOLT, M8X45-8.8 HEX HEAD ZINC	F81002-17	48	
15	WASHER, 8.4 FLAT ZINC	F81054-1	136	
16	NUT, M8-8-B HEX NYLON ZINC LOCK	F81032-2	70	
17	TUBE, SIDE GUARD SUPPORT	504197-1	4	
18	BOLT, M10x110 8.8 HEX HEAD ZINC	F81003-43	8	
19	NUT, M10-8-B NYLON HEX ZINC LOCK	F81033-1	8	
20	WASHER, 10.5 FLAT ZINC	F81055-1	16	
21	BARRIER, TVS SC/FT 3.6 SIDE FRONT	509784-1	2	
22	BARRIER, TVS SC/FT 3.6 SIDE REAR	509783-1	2	
23	BRACKET, SIDE BARRIER CONNECTION	509785-1	1	
24	BOLT, M8x100-8.8 HEX HEAD ZINC	F81002-23	8	
25	PLATE, CONNECTION BRACKET MOUNTING	509779-1	2	
26	BOLT, M8x70 8.8 HEX HEAD ZINC	F81002-71	12	
27	BOLT, M8x110-8.8 HEX HEAD ZINC	F81002-53	2	

5.18 Alignment Tool

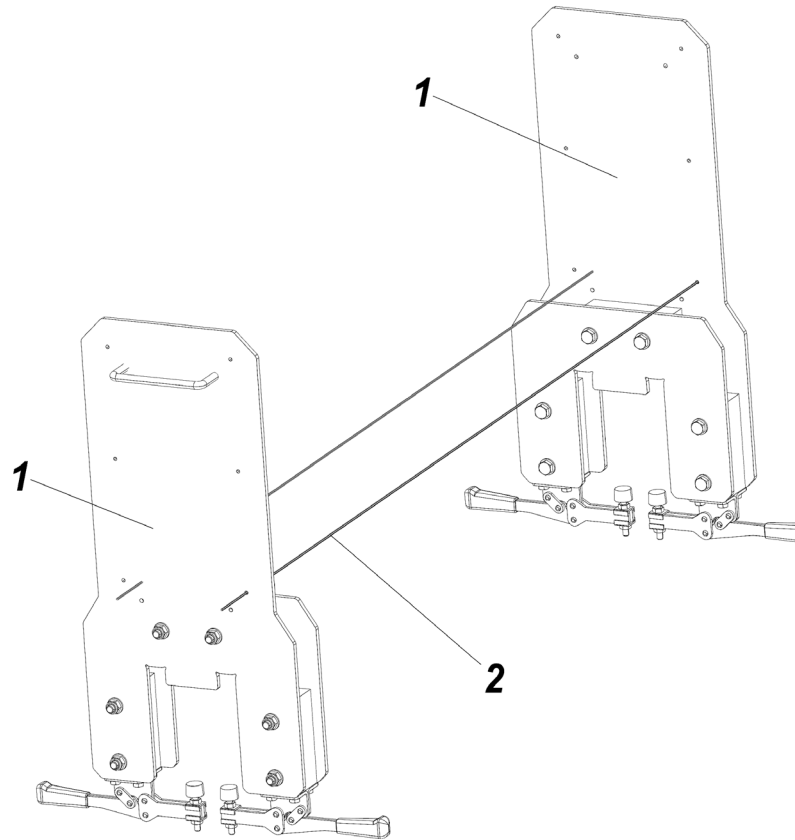

REF.	DESCRIPTION (◆ Indicates Parts Available In Assemblies Only)	PART#	QTY.
	TOOL ASSEMBLY, TVS-SC TABLE	505143	1
1	TOOL, TVS-SC TABLE ALIGNMENT	504551 ¹	2
2	STRING, 2X20m	099604	2

¹ See Section 5.19

5.19 Alignment Tool

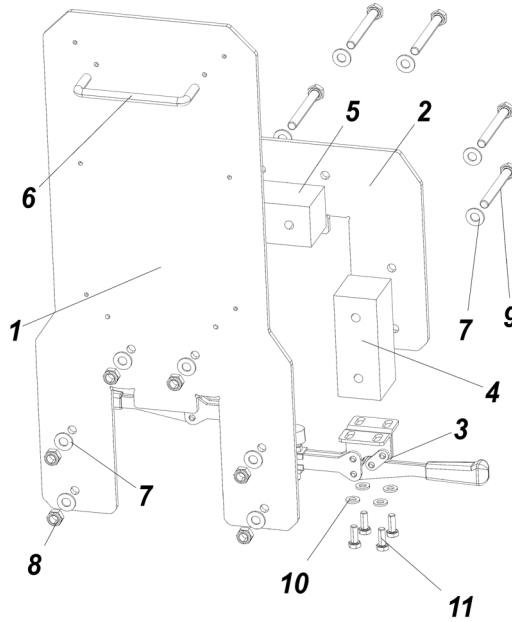

REF.	DESCRIPTION (◆ Indicates Parts Available In Assemblies Only)	PART#	QTY.
	TOOL, TVS-SC TABLE ALIGNMENT	504551	1
1	PLATE, FRONT	504552-1	1
2	PLATE, REAR	504553-1	1
3	CLAMP, 012 ALIGNMENT TOOL	090277	2
4	BLOCK, ALIGNMENT TOOL SPACER	504554	2
5	BLOCK, UPPER SPACER	504555	1
6	HANDLE 4"	P08065	1
7	WASHER, 8.4 FLAT ZINC	F81054-1	12
8	NUT, M8-8-B HEX NYLON ZINC LOCK	F81032-2	6
9	BOLT, M8X70 8.8 HEX HEAD ZINC	F81002-71	6
10	WASHER, 6.4 FLAT ZINC	F81053-1	8
11	BOLT, M6x16-8.8 HEX HEAD FULL THREAD ZINC	F81001-15	8

5.20 Laser Assembly (Option)

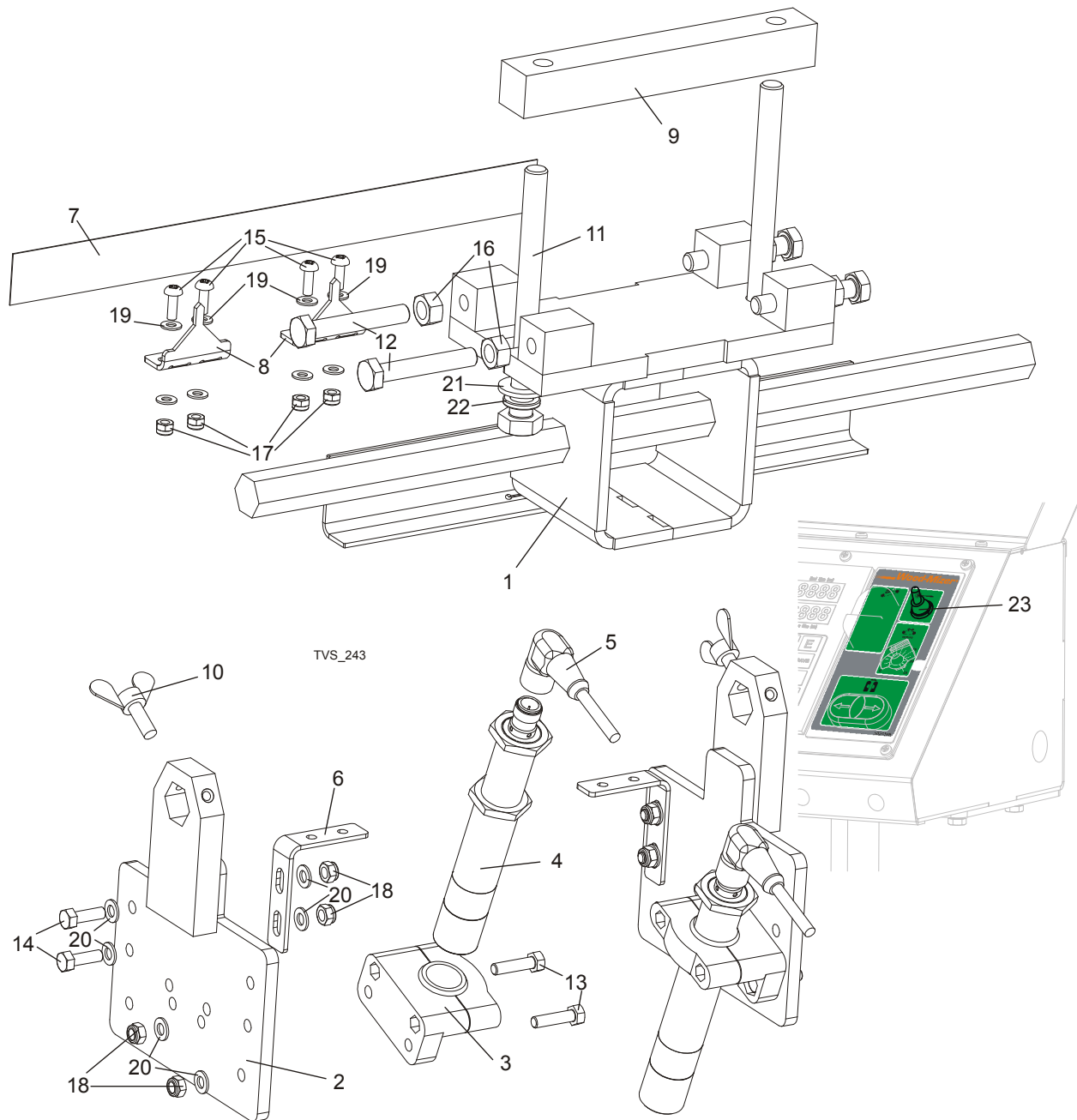

REF.	DESCRIPTION (◆ Indicates Parts Available In Assemblies Only)	PART #	QTY.
	LASER ASSEMBLY, TVS-SC TABLE	505009	1
1	MOUNT WELDMENT, TVS LASER ZINC-PLATED	505010-1	1
2	BRACKET, LASER MOUNTING - COMPLETE	505015-1	2
3	BRACKET, SMB18SF LASER	503469	2
4	LASER, Z5M18B-F-532-IG90 GREEN LINEAR	501025	2
5	CABLE, 10 M 4-WIRE	094291	2
6	BRACKET, SCALE INDICATOR ZINC-PLATED	505311-1	2

TVS-SC INFEED & OUTFEED TABLES

Laser Assembly (Option)

5

7	DECAL, SCALE	505018	1	
8	INDICATOR, SCALE ZINC-PLATED	505017-1	2	
9	BAR, TVS ROLLER BRACKET MOUNTING	100757-1	1	
10	SCREW, M6x16 BN276 DIN 316 THUMB	F81001-16	2	
11	BOLT, M10x115-8.8 HEX HEAD ZINC	F81003-19	2	
12	BOLT, M8X50-8.8 HEX HEAD FULL THREAD ZINC	F81002-19	4	
13	BOLT, M5X20 8.8 ZINC-PLATED	F81000-35	4	
14	BOLT, M5x16 -8.8 HEX HEAD FULL THREAD ZINC	F81000-20	4	
15	SCREW, M4x12 -5,8-B CROSS RECESSED PAN HEAD ZINC	F81011-43	4	
16	NUT, M8-8-B HEX ZINC	F81032-1	4	
17	NUT, M4-B HEX NYLON ZINC LOCK	F81029-1	4	
18	NUT, M5-8 DIN 985 ZINC-PLATED	F81030-2	8	
19	WASHER, 4.3 FLAT ZINC	F81051-2	8	
20	WASHER, 5.3 FLAT ZINC	F81052-1	12	
21	WASHER, 10.5 FLAT ZINC	F81055-1	2	
22	WASHER, 10.2 SPLIT LOCK ZINC	F81055-2	2	
23	SWITCH, SPST ON/OFF 15A .25 TABS TOGGLE	P03027	1	
	ELEMENT, SR1718 SELF-ADHESIVE MOUNTING	087695	15	
	WIRE TIE, TK 9/3 PLASTIC	F81082-4	15	
	BOOT, TOGGLE SWITCH	P02575	1	
	WASHER, 1/2X3/4X1/16 NYLON	P05251-1	1	
	POWER SUPPLY, 24V 1A	501336	1	

SECTION 6 INCLINE LOG DECK

6.1 Infeed Assembly

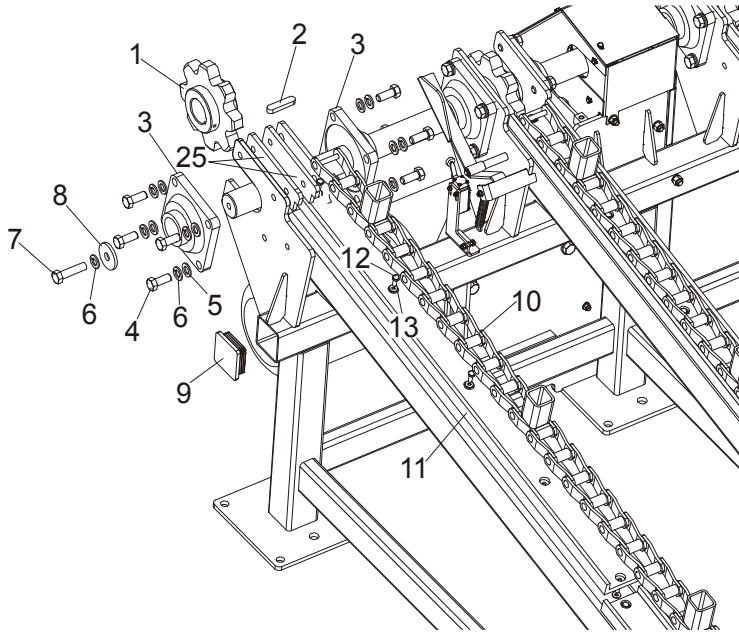

TVS_039_A

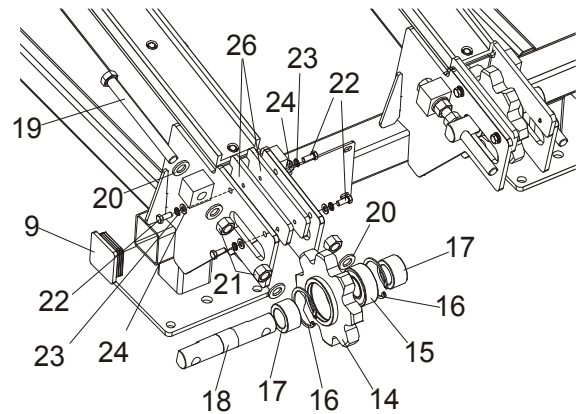

REF	DESCRIPTION (◆ Indicates Parts Available In Assemblies Only)	PART #	QTY.
	TVS INCLINE LOG DECK	097999	1
1	SPROCKET, Z8 OXIDIZED	089888-1	4
2	KEY, A16X10X70 PARALLEL	098029	4
3	BEARING, UCF 211W/HOUSING (55 DIA. SHAFT)	089889	8
4	BOLT, M16x45-8.8 HEX HEAD FULL THREAD ZINC	F81006-46	32
5	WASHER, 17 FLAT ZINC	F81058-1	48
6	WASHER, 16.3 SPLIT LOCK ZINC	F81058-2	48
7	BOLT, M16x65-8.8-B HEX HEAD FULL THREAD ZINC	F81006-1	4
8	WASHER, TVS SPECIAL	098012-1	2

9	CAP, FRAME TUBE	089644	4	
10	CHAIN, TVS INCLINE LOG DECK 5940mm 89 LINKS	504582	4	
11	CHANNEL, UHMW CONVEYOR	033722	8	
12	BOLT, M8x20-5.8 HEX HEAD FULL THREAD ZINC	F81002-1	40	
13	WASHER, 6.5 SPECIAL FLAT ZINC	F81053-11	40	
14	SPROCKET, Z8 REAR OXIDIZED	089919-1	4	
15	BEARING, 3208B.2RSR.TVH FAG	088449	4	
16	RING, W80 INSIDE RETAINING	F81090-25	8	
17	BUSHING, SPROCKET SPACER	089916-1	8	
18	SHAFT, CHAIN TENSION SPROCKET	089915-1	4	
19	BOLT, M20x240-8.8 HEX HEAD FULL THREAD ZINC	F81007-1	8	
20	WASHER, 21 FLAT ZINC	F81059-2	24	
21	NUT, M20-8 HEX ZINC	F81037-1	16	
22	Bolt, M10-1.5x25mm HH Gr8.8	F81003-11	16	
23	WASHER, 10.2 SPLIT LOCK ZINC	F81055-2	16	
24	WASHER, M10 FLAT ZINC	F81055-1	16	
25	PLATE, DRIVE SIDE,SPACER	509026-1	8	
26	PLATE, IDLE SIDE, SPACER	509027-1	8	

6.2 Additional Grid, Option For TVS Incline Log Deck

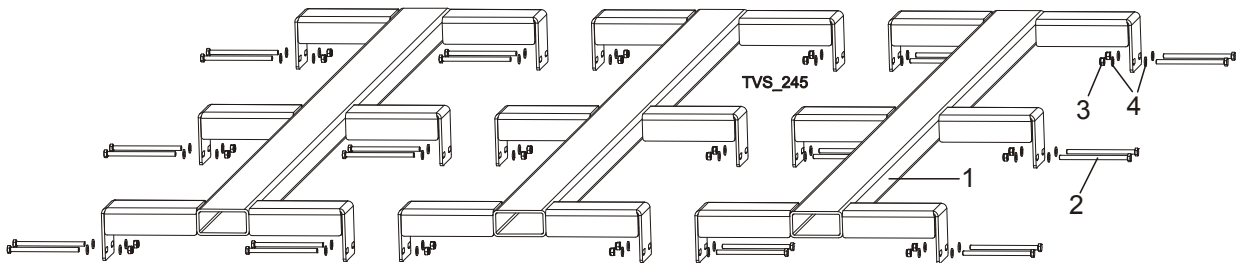

REF	DESCRIPTION (◆ Indicates Parts Available In Assemblies Only)	PART #	QTY.
	GRID ADDITIONAL TVS INCLINE LOG DECK COMPLETE.	505855	1
1	GRID ADDITIONAL TVS INCLINE LOG DECK	505854-1	3
2	BOLT M8x130-8.8-HEX HEADZINC	F81002-50	24
3	NUT,M8-8-B,HEX NYLON LOCK ZINC	F81032-2	24
4	WASHER, 8.4 FLAT ZINC	F81054-1	48

6.3 Limit Switch Assembly

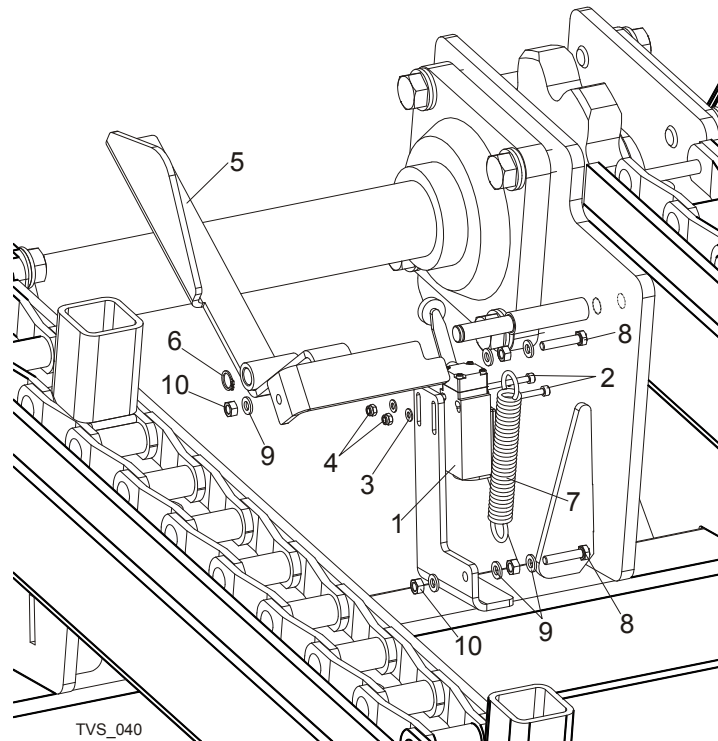

REF	DESCRIPTION (◆ Indicates Parts Available In Assemblies Only)	PART #	QTY.
1	LIMIT SWITCH, GLCB01A2B	086469	1
2	SCREW, M4X35-8.8 HEX SOCKET HEAD CAP ZINC	F81011-34	2
3	WASHER, 4.3 FLAT ZINC	F81051-2	2
4	NUT, M4-B HEX NYLON LOCK ZINC	F81029-1	2
5	ARM, TVS LIMIT SWITCH ACTIVATOR - COMPLETE	098474-1	1
6	RING, Z12 OUTSIDE RETAINING	F81090-14	1
7	SPRING, FI 1.9 X FI 14.2 X 104	091865	1
8	BOLT, M6X30 5.8 HEX HEAD FULL THREAD	F81001-13	2
9	WASHER, 6.4 FLAT ZINC	F81053-1	6
10	NUT, M6-8 HEX ZINC	F81031-1	4

6.4 Drive Assembly

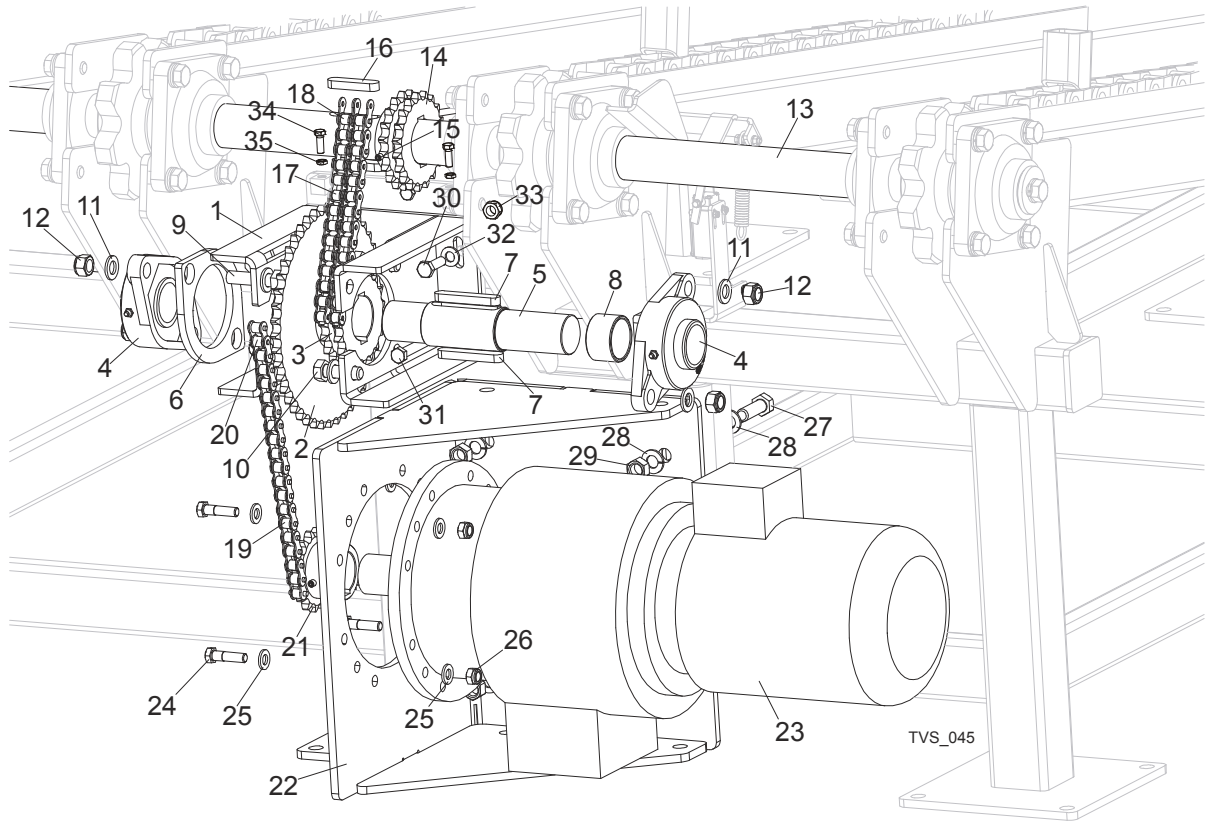

REF	DESCRIPTION (◆ Indicates Parts Available In Assemblies Only)	PART #	QTY.
	GEAR ASSEMBLY, TVS INCLINE LOG DECK	098424	1
1	BRACKET WELDMENT, TVS SPROCKET MOUNTING	098422-1	1
2	SPROCKET, 12B Z45 OXIDIZED	089894-1	1
3	SPROCKET, 12B Z19	098013-1	1
4	BEARING, UCFL 210 CX W/HOUSING	098824	2
5	SHAFT, INTERMEDIATE SPROCKET ZINC-PLATED	098419-1	1
6	PLATE, FL 210 BEARING SPACER	099106-1	1
7	KEY, A16X10X90 PARALLEL	099131	2
8	SPACER, TVS SPROCKET	098011-1	1
9	BOLT, M16 THIN	099647	2
10	BOLT, M16x50-8.8 HEX HEAD FULL THREAD ZINC	F81006-7	2
11	WASHER, 17 FLAT ZINC	F81058-1	8
12	NUT, M16-8 HEX NYLON LOCK ZINC	F81036-2	4
13	SHAFT, TVS INCLINE LOG DECK MAIN	098010	1
14	SPROCKET, 12B Z19	098013-1	1
15	SCREW, M8X8-33H HEX SOCKET SET FLAT POINT ZINC	F81014-1	4
16	KEY, A16X10X70 PARALLEL	098029	2
17	CHAIN, 12B-2-41 (0.8 RM)	099250	1
18	LINK, 12B-1PZ CHAIN	099249	1

6

Incline Log Deck*Drive Assembly*

19	CHAIN, 12B-1-65 (1.25 RM)	099248	1	
20	LINK, 12B-1PZ CHAIN	090713	1	
21	SPROCKET, 12B Z16 OXIDIZED	090303-1	1	
22	BRACKET WELDMENT, DECK MOTOR MOUNT	089897-1	1	
23	MOTOREDUCER, SBCM 180/112M-4/32	089892	1	
24	BOLT, M12X45-8.8 HEX HEAD ZINC	F81004-32	4	
25	WASHER, 13 FLAT ZINC	F81056-1	8	
26	NUT, M12-8 HEX NYLON LOCK ZINC	F81034-2	4	
27	BOLT, M16X50-8.8 HEX HEAD FULL THREAD ZINC	F81006-7	4	
28	WASHER, 17 FLAT ZINC	F81058-1	8	
29	NUT, M16-5.8 HEX ZINC	F81036-1	4	
30	BOLT, M12X40-8.8 HEX HEAD FULL THREAD ZINC	F81004-4	2	
31	BOLT, M12X120 8.8 HEX HEAD ZINC	F81004-38	2	
32	WASHER, 13 FLAT ZINC	F81056-1	8	
33	NUT, M12-8-B HEX ZINC	F81034-1	4	
34	BOLT, M10X50MM,HEX HEAD FULL THRD ZINC	F81003-4	2	
35	NUT, M10-8-B-HEX ZINC	F81033-3		

6.5 Chain Guards

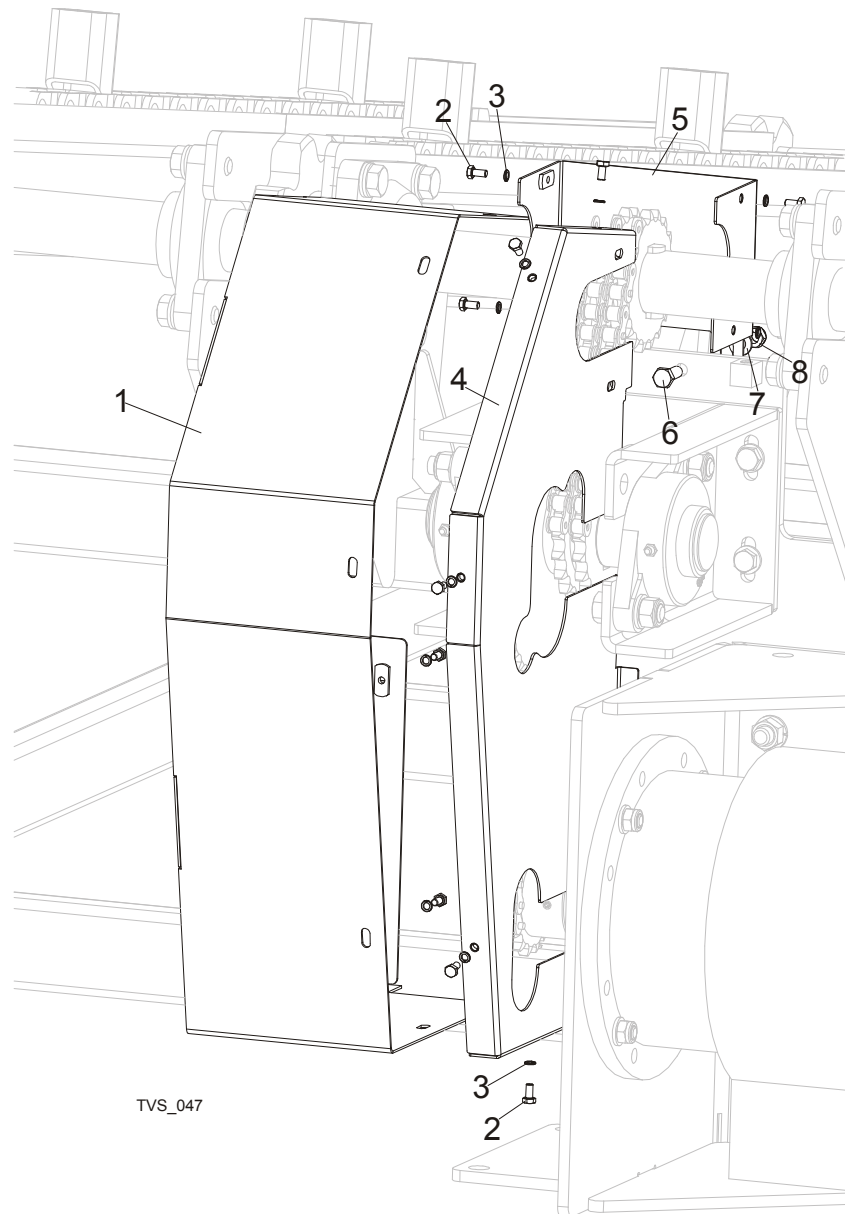

REF	DESCRIPTION (◆ Indicates Parts Available In Assemblies Only)	PART #	QTY.
1	GUARD, TVS ILD GEAR - MAIN	098467-1	1
2	BOLT, M6X12-8.8 HEX HEAD FULL THREAD ZINC	F81001-7	11
3	WASHER, Z 6.1 SPLIT LOCK ZINC	F81053-3	11
4	GUARD, TVS ILD GEAR - SIDE	098470-1	1
5	GUARD, TVS REAR	098469-1	1
6	BOLT, M10X30-5.8 HEX HEAD FULL THREAD ZINC	F81003-2	1
7	WASHER, 10.5 FLAT ZINC	F81055-1	1
8	NUT, M10-8-B HEX NYLON LOCK ZINC	F81033-1	1

6.6 Decals

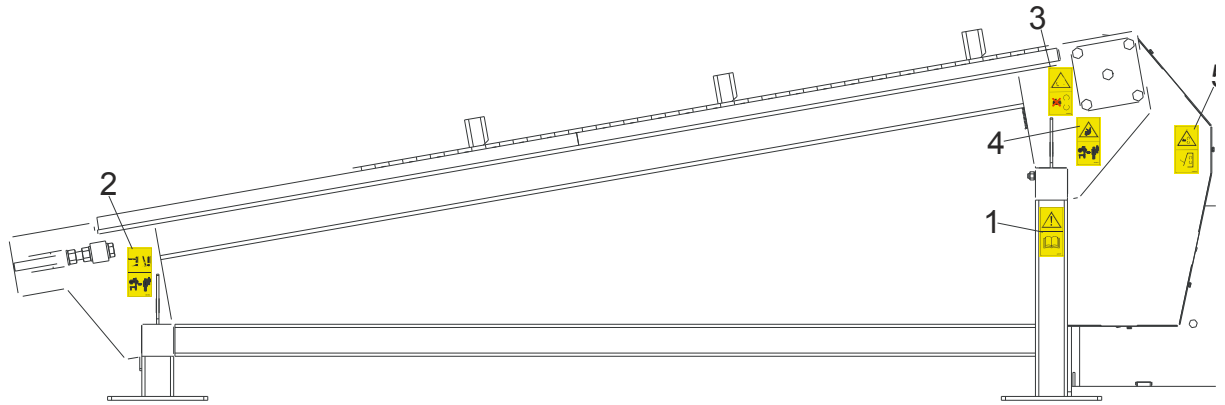

TVS_048

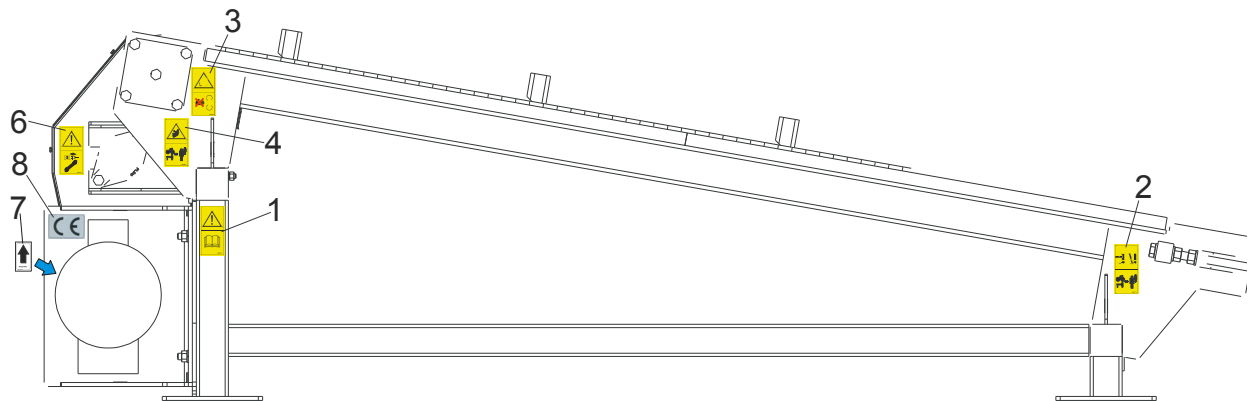

REF	DESCRIPTION (◆ Indicates Parts Available In Assemblies Only)	PART #	QTY.
	DECALS KIT, PICTOGRAMS, INCLINE LOG DECK	099579	1
1	Decal, read operator's manual (pictogram)	096317	2
2	Decal, keep away warning (pictogram)	096314	2
3	Decal, gear danger (pictogram)	099540	2
4	Decay, keep away warning (pictogram)	099221	2
5	Decal, close all guards and covers before starting the machine	099220	1
6	Decal, disconnect and lock out power supply before servicing (pictogram)	098177	1
7	Decal, 1400 RPM Motor Direction	S20097H	1
8	DECAL, CE - CERTIFIED SAWMILL	P85070	1

SECTION 7 CROSS TRANSFER DECK

7.1 Front Module & Chains

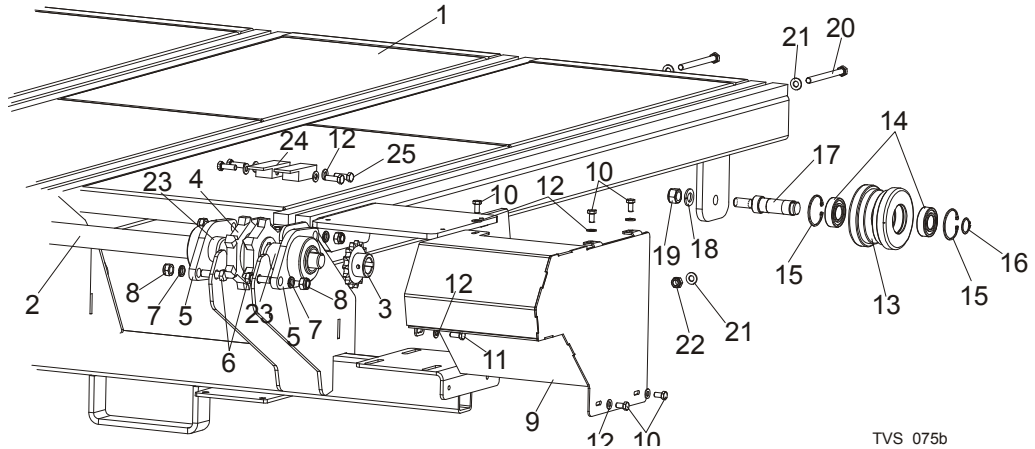

TVS 075b

REF	DESCRIPTION (◆ Indicates Parts Available In Assemblies Only)	PART #	QTY.
	COMPLETE FRONT MODULE	099556	1
1	FRAME WELDMENT, CTD FRONT	097899-1	1
2	SHAFT, CTD DRIVE	097893	1
3	SPROCKET, 10B Z 15 INCLINE CONVEYOR	095162	1
4	SPROCKET, 16B 20Z	097657	4
5	BEARING, FYTB 40 KG	097898	8
6	BOLT, SPROCKET MOUNTING	091744	16
7	WASHER, 17 FLAT ZINC	F81058-1	16
8	NUT, M16 HEX NYLON ZINC LOCK	F81036-2	16
9	COVER, CTD CHAIN	097903-1	1
10	BOLT, M8x16-8.8 HEX HEAD ZINC	F81002-20	5
11	BOLT, M8X20-8.8-B HEX HEAD FULL THREAD ZINC	F81002-4	1
12	WASHER, 8.4 FLAT, ZINC	F81054-1	22
	WHEEL, CTD COMPLETE	098492	4
13	TENSIONER, CTD CHAIN	098493	1
14	BEARING, SKF 6205-2RS ROLLER	087353	2
15	RING, W52 INSIDE RETAINING	F81090-6	2
16	RING, 25Z OUTSIDE RETAINING	F81090-22	1
17	SHAFT, CTD CHAIN TENSIONER	098494	1
18	WASHER, 16.3 SPLIT LOCK ZINC	F81058-2	4
19	NUT, M16-8 HEX NYLON ZINC LOCK	F81036-2	4
20	BOLT, M10x125-8.8 HEX HEAD ZINC	F81003-18	6
21	WASHER, 10.5 FLAT ZINC	F81055-1	12
22	NUT, M10-8-B HEX NYLON ZINC LOCK	F81033-1	6
23	BUSHING, FI 40 x FI 48x14 SPACER	099958-1	8
24	Bar, Flat	508973-1	8
25	BOLT, M8X25-8.8-B HEX HEAD FULL THRE	F81002-5	16
	CHAIN, SLPCTD3.6 ZINC-PLATED	099310	4

7 CROSS TRANSFER DECK

Front Module & Chains

	CHAIN, SLPCTD5.4	099571	4	
	CHAIN, CTC7.2	099572	4	

7.2 Central Module

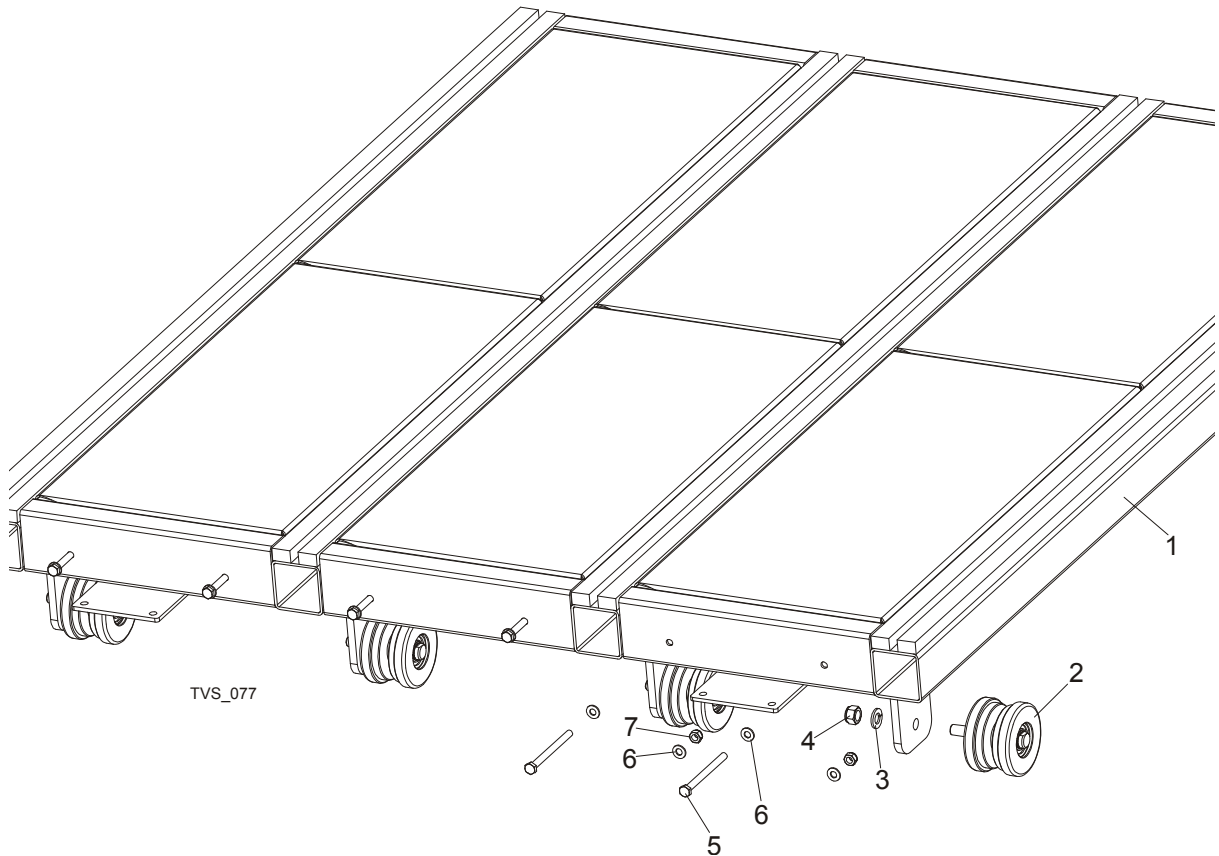

REF	DESCRIPTION (◆ Indicates Parts Available In Assemblies Only)	PART #	QTY.
	COMPLETE CENTRAL MODULE	099557	1/2 ¹
1	MODULE, CTD CENTRAL PAINTED	098125-1	1
2	WHEEL, CTD COMPLETE	098492	4
3	WASHER, 16.3 SPLIT LOCK ZINC	F81058-2	4
4	NUT, M16-8 HEX NYLON ZINC LOCK	F81036-2	4
5	BOLT, M10x125-8.8 HEX HEAD ZINC	F81003-18	6
6	WASHER, 10.5 FLAT ZINC	F81055-1	12
7	NUT, M10-8-B HEX NYLON ZINC LOCK	F81033-1	6

¹ Used on CTD5.4 - 1 piece and on CTD7.2 - 2 pieces.

7.3 Rear Module

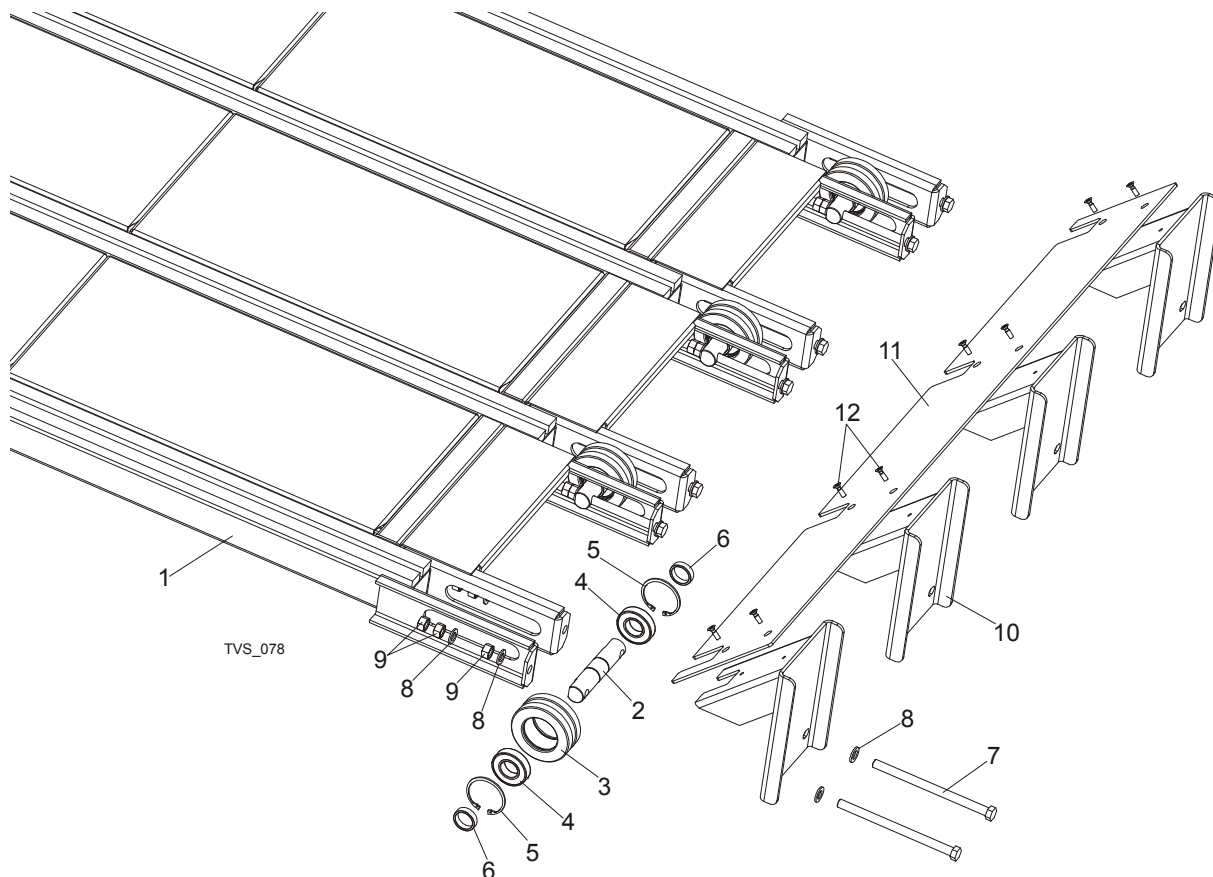

REF	DESCRIPTION (◆ Indicates Parts Available In Assemblies Only)	PART #	QTY.
	COMPLETE REAR MODULE	099558	1
1	FRAME WELDMENT, CTD REAR PTD	097900-1	1
	COMPLETE CHAIN TENSION WHEEL	097655	4
2	SHAFT, CHAIN TENSION WHEEL	096207-1	1
3	WHEEL, TVS CHAIN TENSION	096208-1	1
4	BEARING, 6207-2RS, C3, 35X72X17	014811	2
5	RING, W72 INSIDE RETAINING	F81090-4	2
6	BUSHING, FI 36x FI 44x22 SPACER ZINC	099959-1	8
7	BOLT, M16X240-8.8-A2 FULL THREAD	F81006-29	8
8	WASHER, 17 FLAT ZINC	F81058-1	24
9	NUT, M16-5.8 HEX ZINC	F81036-1	24
	BUMPER ASSEMBLY	099560-1	1
10	BRACKET, BUMPER MOUNTING	098223-1	4
11	PLATE, CTD BUMPER	098496-1	1
12	SCREW, M8X25 CROSS RECESSED COUNTERSUNK HEAD	F81002-51	8

7.4 Cross Transfer Deck Drive

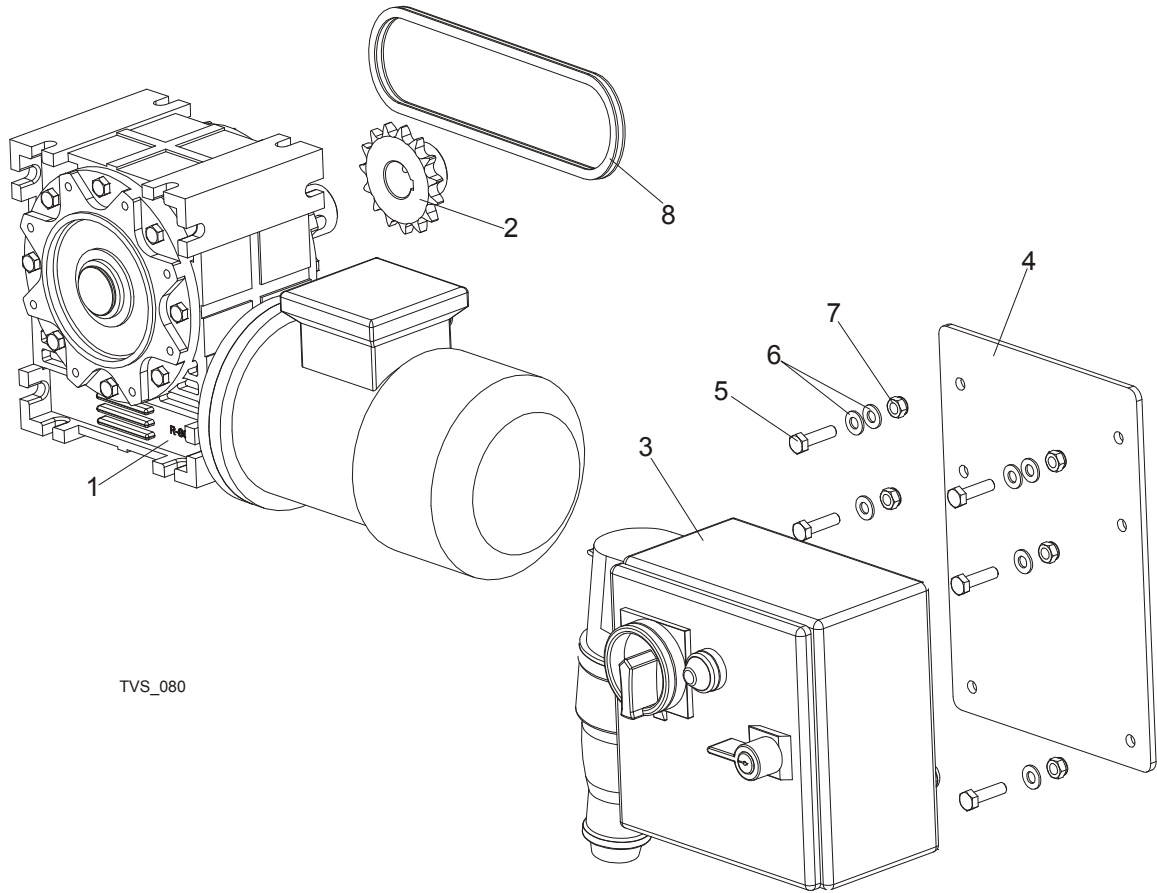

TVS_080

REF	DESCRIPTION (◆ Indicates Parts Available In Assemblies Only)	PART #	QTY.
	MOTOR KIT	099559	1
1	MOTOREDUCER, MR-80/64-1.1-1400/K3/V6	098663	1
2	SPROCKET, 10B Z 15 INCLINE CONVEYOR	095162	1
3	BOX, CTD ELECTRIC	098826	1
4	PANEL, CTD ELECTRIC BOX	099550-1	1
5	BOLT, M8X30-5.8 HEX HEAD FULL THREAD ZINC	F81002-2	6
6	WASHER, 8.4 FLAT ZINC	F81054-1	8
7	NUT, M8-8-B HEX NYLON ZINC LOCK	F81032-2	6
8	CHAIN, 10B-48PZ	099781	1

7.5 Leg Kits

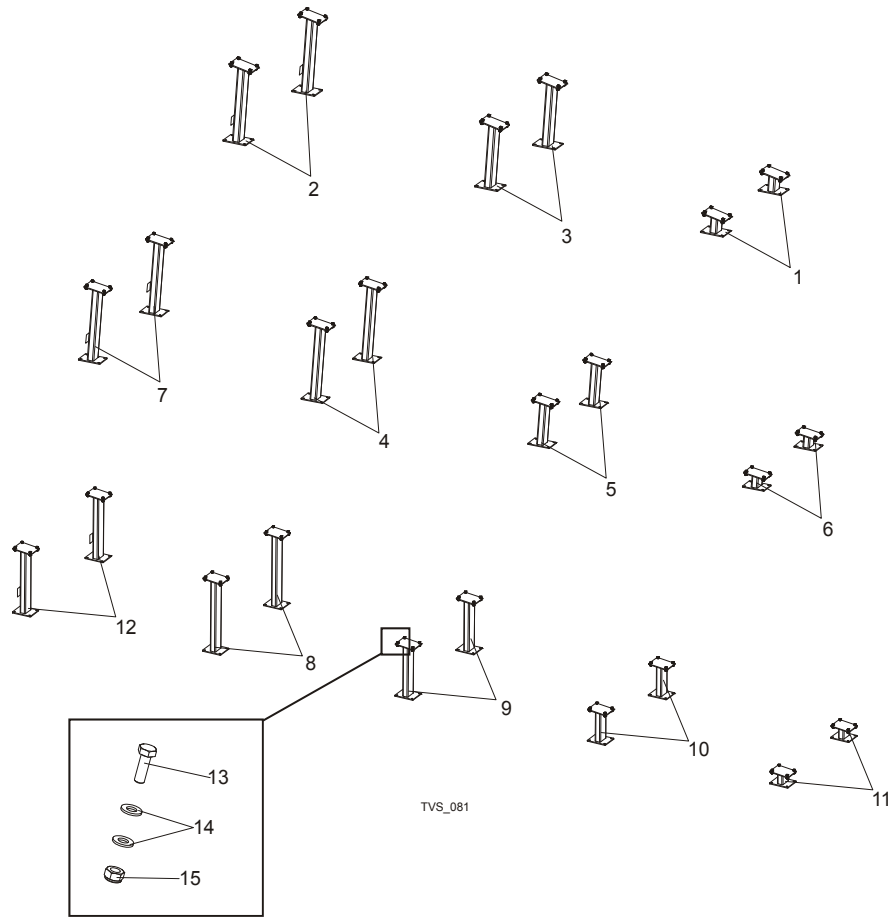

REF	DESCRIPTION (◆ Indicates Parts Available In Assemblies Only)	PART #	QTY.	
	LEG KIT, CTD SHORT	099554	1	
1	LEG, 7.6M REAR PTD	099279-1	2	
2	LEG, FRONT PTD	099415-1	2	
3	LEG, REAR PTD	099416-1	2	
	LEG KIT, CTD MEDIUM	099568	1	
4	LEG, CTD5.4 MIDDLE PTD (1)	099573-1	2	
5	LEG, CTD5.4 MIDDLE PTD (2)	099574-1	2	
6	LEG, CTD5.4 REAR PTD	099575-1	2	
7	LEG, CTD5.4 FRONT PTD	099576-1	2	
	LEG KIT, CTD LONG	099553	1	
8	LEG, CTD7.2 MIDDLE PTD (1)	099277-1	2	
9	LEG, CTD7.2 MIDDLE PTD (2)	099278-1	2	
10	LEG, CTD7.2 MIDDLE PTD (3)	099562-1	2	
11	LEG, CTD7.2 REAR PTD	099564-1	2	
12	LEG, CTD7.2 FRONT PTD	099566-1	2	
13	BOLT, M10x30-5.8 HEX HEAD FULL THREAD ZINC	F81003-2	24/32/40	
14	WASHER, 10.5 FLAT ZINC	F81055-1	48/64/80	
15	NUT, M10-8-B HEX NYLON ZINC LOCK	F81033-1	24/32/40	

7.6 Slabs Table

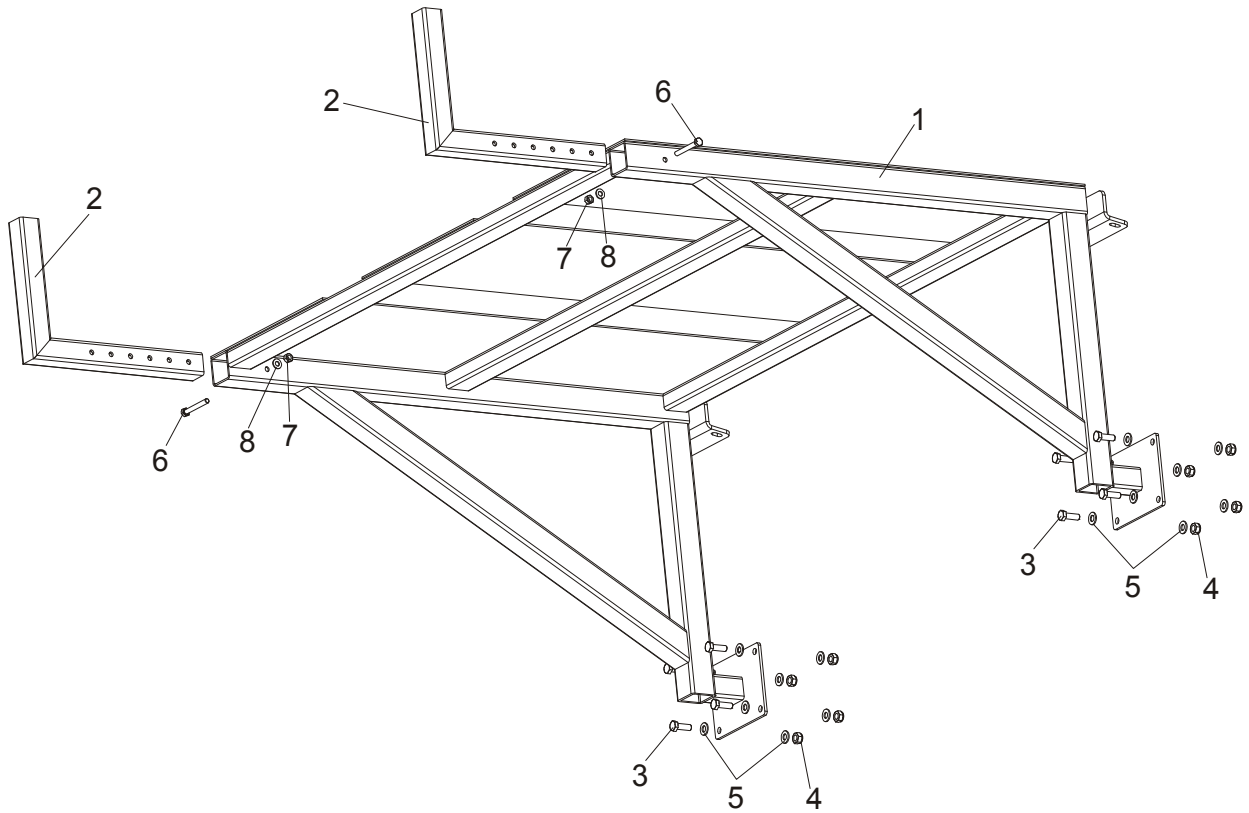

REF	DESCRIPTION (◆ Indicates Parts Available In Assemblies Only)	PART #	QTY.
1	TABLE, SLPCTD HIGH	100517-1	1
2	ARM, TABLE LOCK	100531-1	2
3	BOLT, M10X30-5.8 HEX HEAD FULL THREAD	F81003-2	8
4	NUT, M10-8-B NYLON HEX ZINC LOCK	F81033-1	16
5	WASHER, 10.5 FLAT ZINC	F81055-1	8
6	BOLT, M8X65 8.8 HEX HEAD ZINC	F81002-9	2
7	NUT, M8 HEXAGON, GRADE 5.8 FREE ZINC	F81032-1	2
8	WASHER, 8.4 FLAT ZINC	F81054-1	2

7.7 Decals

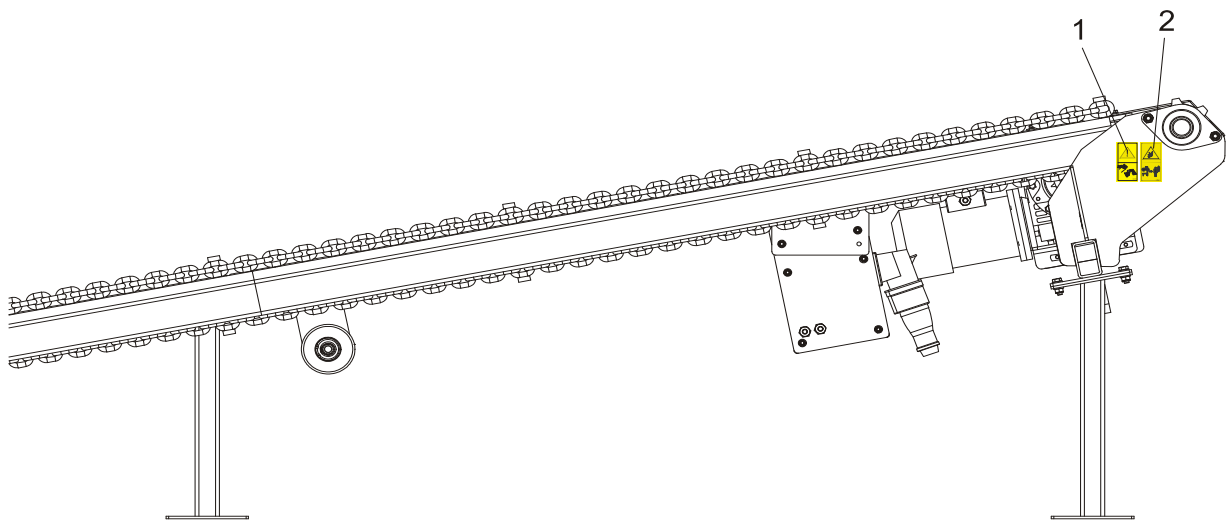
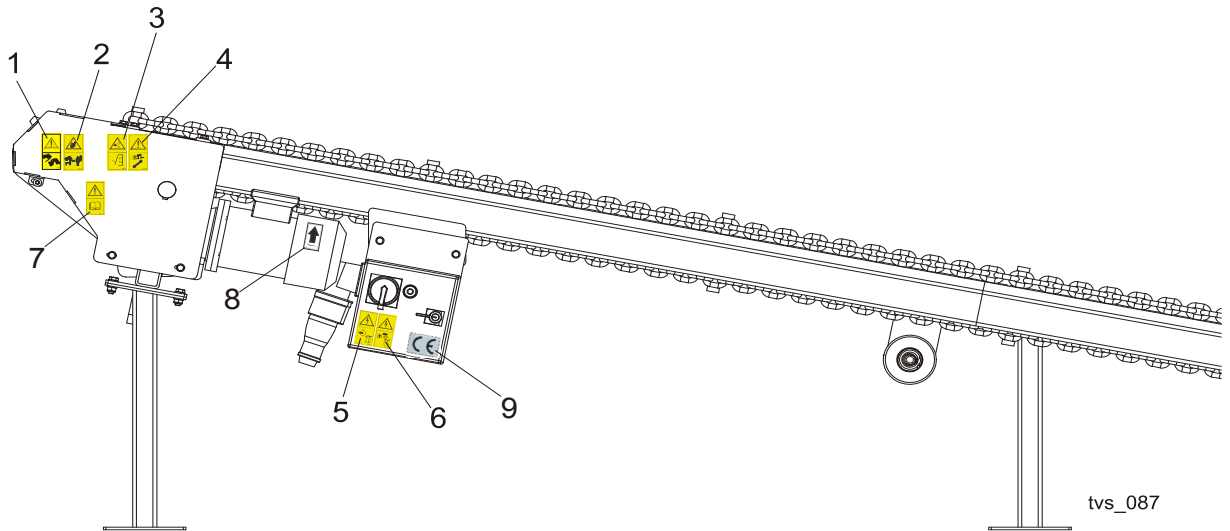

REF	DESCRIPTION (◆ Indicates Parts Available In Assemblies Only)	PART #	QTY.
	DECALS KIT, PICTOGRAMS, CROSS TRANSFER DECK	099835	1
1	Decal, Look out for the falling slabs (PICTOGRAM)	099780	2
2	Decay, Keep away warning (pictogram)	099221	2
3	Decal, Close all guards and covers before starting the machine	099220	1
4	Decal, Disconnect and lock out power supply before servicing (pictogram)	098177	1
5	Decal, High voltage inside the electric box (pictogram)	096316	1
6	Decal, Remove the plug before opening the box (pictogram)	096319	1
7	Decal, Read operator's manual (pictogram)	096317	1
8	Decal, 1400 RPM motor direction	S20097H	1
9	DECAL, CE - CERTIFIED SAWMILL	P85070	1