

Cross Transfer Deck

Safety, Operation and Maintenance Manual

CC4 3.6

rev.A9.02

CC4 5.4

rev.A9.02

CC4 7.2

rev.A9.02



Safety is our #1 concern! Read and understand all safety information and instructions before operating, setting up and/or maintaining this equipment.

Form #1011

Table of Contents

Section-Page

SECTION 1	SAFETY INSTRUCTIONS	1-1
1.1	Safety Symbols.....	1-1
1.2	Safety Instructions.....	1-2
SECTION 2	OPERATION	2-1
2.1	Cross Transfer Deck Components.....	2-1
2.2	Transfer Deck Setup.....	2-2
2.3	Transfer Deck Operation.....	2-4
SECTION 3	MAINTENANCE	3-1
3.1	Lubrication.....	3-1
3.2	Transfer Chain Tension.....	3-2
3.3	Drive Chain Tension.....	3-3
SECTION 4	SPECIFICATIONS	4-1
4.1	Transfer Deck Dimensions.....	4-1
4.2	Motor Specifications.....	4-7
SECTION 5	CROSS TRANSFER DECK	5-1
5.1	Front Module & Chains.....	5-1
5.2	Central Module.....	5-3
5.3	Rear Module.....	5-4
5.4	Cross Transfer Deck Drive.....	5-5
5.5	Leg Kits.....	5-6
5.6	Slabs Table.....	5-7
5.7	Decals.....	5-8
SECTION 6	CC4-3_6C-UL	6-1
6.1	Cross Transfer Deck CC4-3_6C-UL.....	6-2
6.2	Front Module 099556.....	6-3
6.3	Rear Module 599558.....	6-5
6.4	Slab Stop Assembly 099560.....	6-6
6.5	Electric Box CC4_C-UL. 507253-UL.....	6-7
6.6	Leg Kits 099554.....	6-8
SECTION 7	CC4-WIDE-SLP2-001 CHAIN CONVEYOR	7-1
7.1	Chain Conveyor.....	7-1
7.2	Front Leg.....	7-2
7.3	Middle Leg.....	7-3
7.4	Rear Leg.....	7-4
7.5	Front Module.....	7-5

Table of Contents

Section-Page

7.6 Rear Module7-7
7.7 Slab Stop Assembly7-8
7.8 Motor Kit7-9
7.9 Electric Box Assembly7-10

SECTION 1 SAFETY INSTRUCTIONS

1.1 Safety Symbols

The following symbols and signal words call your attention to instructions concerning your personal safety. Be sure to observe and follow these instructions.



The word **DANGER** indicates an imminently hazardous situation which, if not avoided, will result in death or serious injury.



WARNING! suggests a potentially hazardous situation which, if not avoided, could result in death or serious injury.



CAUTION refers to potentially hazardous situations which, if not avoided, may result in minor or moderate injury to persons or equipment.



IMPORTANT! indicates vital information.

NOTE: gives helpful information.



Warning stripes are placed on areas where a single decal would be insufficient. To avoid serious injury, keep out of the path of any equipment marked with warning stripes.

1.2 Safety Instructions

NOTE: ONLY safety instructions regarding personal injury are listed in this section. Caution statements regarding only equipment damage appear where applicable throughout the manual.

Observe Safety Instructions



IMPORTANT! Read the entire Operator's Manual before operating the unit. Take notice of all safety warnings throughout this manual and those posted on the equipment. Keep this manual with this equipment at all times, regardless of ownership.

Also read any additional manufacturer's manuals and observe any applicable safety instructions including dangers, warnings, and cautions.

Only persons who have read and understood the entire operator's manual should operate this equipment. The equipment is not intended for use by or around children.



IMPORTANT! It is always the owner's responsibility to comply with all applicable federal, state and local laws, rules and regulations regarding the ownership, operation and towing of your Wood-Mizer equipment.



1

SAFETY INSTRUCTIONS

Wear Safety Clothing

Wear Safety Clothing



WARNING! Secure all loose clothing and jewelry before operating this equipment. Failure to do so may result in serious injury or death.

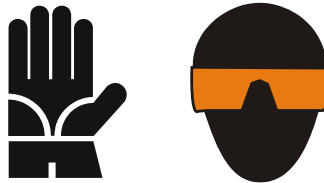

WARNING! Always wear eye, ear, respiration and foot protection as well as safety clothing when operating or servicing the equipment.



Keep the Equipment and Area Around Clean



DANGER! Maintain a clean and clear path for all necessary movement around the equipment and lumber stacking areas. Failure to do so may result in serious injury.

Dispose Of Sawing By-Products Properly



IMPORTANT! Always properly dispose of all sawing by-products, including sawdust and other debris.

Check the Equipment Before Operation



DANGER! Make sure all guards and covers are in place and secured before operating the equipment. Failure to do so may result in serious injury.



Keep Persons Away



DANGER! Keep all persons out of the path of moving equipment and lumber when operating the equipment. Failure to do so may result in serious injury.



DANGER! Be sure that all persons are away from the equipment before starting it. Failure to do so may result in serious injury.

1

SAFETY INSTRUCTIONS

Keep Hands Away

Keep Hands Away



DANGER! Always keep hands away from moving chain. Failure to do so may result in serious injury.



DANGER! Always be aware of and take proper protective measures against rotating shafts, pulleys, fans, etc. Always stay a safe distance from rotating members and make sure that loose clothing or long hair does not engage rotating members resulting in possible injury.



Use Proper Maintenance Procedures



DANGER! Make sure all electrical installation, service and/or maintenance work is performed by a qualified electrician and is in accordance with applicable electrical codes.



DANGER! Hazardous voltage inside the electric box and at the motor can cause shock, burns, or death. Disconnect and lock out power supply before servicing! Keep all electrical component covers closed and securely fastened during equipment operation.





WARNING! Consider all electrical circuits energized and dangerous.



WARNING! Disconnect and lock out power supply before servicing! Failure to do so may result in serious injury.



WARNING! Never assume or take the word of another person that the power is off; check it out and lock it out.



WARNING! Do not wear rings, watches, or other jewelry while working around an open electrical circuit.



CAUTION! The conveyor's work-stand should be equipped with a 4 kg or bigger dry powder extinguisher.

Keep Safety Labels In Good Condition



IMPORTANT! Always be sure that all safety decals are clean and readable. Replace all damaged safety decals to prevent personal injury or damage to the equipment. Contact your local distributor, or call your Customer Service Representative to order more decals.



IMPORTANT! If replacing a component which has a safety decal affixed to it, make sure the new component also has the safety decal affixed.



1 SAFETY INSTRUCTIONS

Safety Labels Description

Safety Labels Description

See Table 1-1. Pictographic safety labels are shown in the table below.

TABLE 1-1

Decal View	Decal No.	Description
	096317	Read thoroughly the operator's manual before operating the equipment. Observe instructions and safety rules when operating.
	099220	Close all guards and covers prior to starting the equipment.
	099221	Keep all persons a safe distance away from work area when operating the unit.

SAFETY INSTRUCTIONS

Safety Labels Description

1

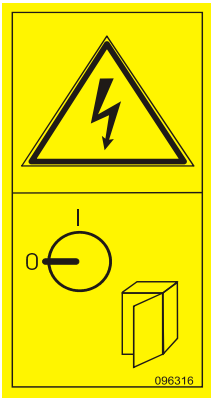
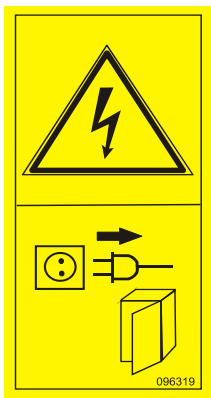
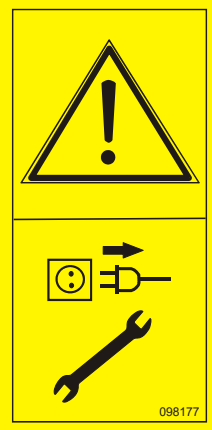

TABLE 1-1

	<p>096314</p>	<p>Keep all persons a safe distance away from work area when operating the unit.</p>
	<p>096316</p>	<p>Do not open or close the electric box when the switch is not in the "0" position.</p>
	<p>096319</p>	<p>Disconnect power supply before opening the box.</p>

1 SAFETY INSTRUCTIONS

Safety Labels Description

TABLE 1-1

	<p>098177</p>	<p>Disconnect power supply before servicing.</p>
	<p>099540</p>	<p>CAUTION! Gear danger – keep a safe distance away!</p>
	<p>S12004G</p>	<p>Always wear safety goggles when operating the equipment.</p>

SAFETY INSTRUCTIONS

Safety Labels Description

1

TABLE 1-1

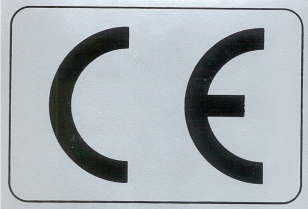
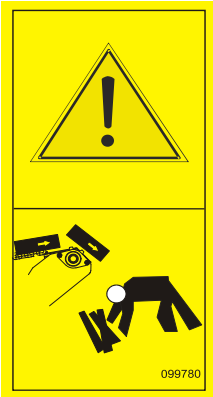
	S12005G	Always wear protective ear muffs when operating the equipment.
	P85070	CE safety certification
	099780	Caution! Slabs falling off the deck!

SECTION 2 OPERATION

2.1 Cross Transfer Deck Components

 **WARNING!** Always stay a safe distance from moving equipment and boards while operating the transfer deck. Failure to do so may result in serious injury or death.

The major components of the Cross Transfer Deck are identified below.

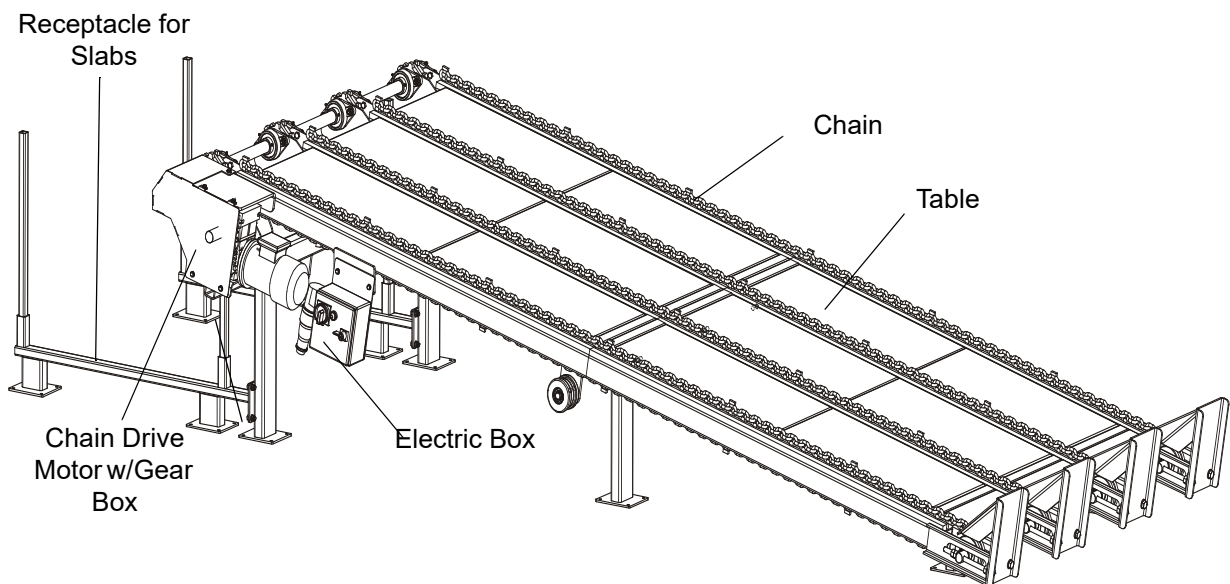

FIG. 2-1 CROSS TRANSFER DECK

2.2 Transfer Deck Setup



IMPORTANT! Before starting to use the transfer deck you have to meet the following conditions.

- Set up the deck on firm and level ground. Fasten the unit to the ground.
- The transfer deck can be operated in temperature range from -20° C to 40° C only.
- The operator's position is shown in the figure below.

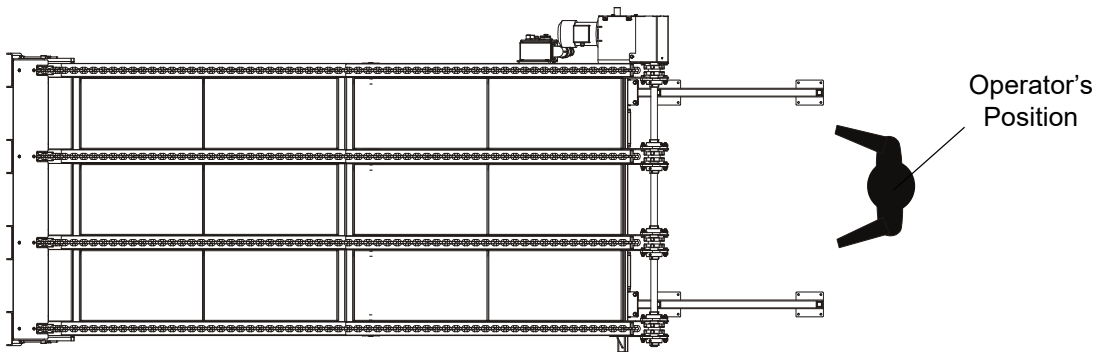

- Have a qualified electrician install the power supply (in accordance with EN 60204 Standard). The power supply must meet the specifications given in the table below.

3-Phase Volts	Fuse Disconnect	Recommended Wire Size
400 VAC	4 A	1.5 mm ²

TABLE. 2-1

2

OPERATION

Transfer Deck Setup



IMPORTANT! When starting the unit for the first time, check that the chain rotation direction is correct. If it is incorrect, invert the phases in the phase inverter located in the power socket (in the electric box).



IMPORTANT! When starting the equipment for the first time, let it run for the first 1-2 hours without load.

The transfer deck can be lifted with a forklift only. The forklift should be rated for at least 1000-1500kg depending on the transfer deck length. The transfer deck is equipped with forklift pockets. Insert the forks into the pockets shown in the figure below.

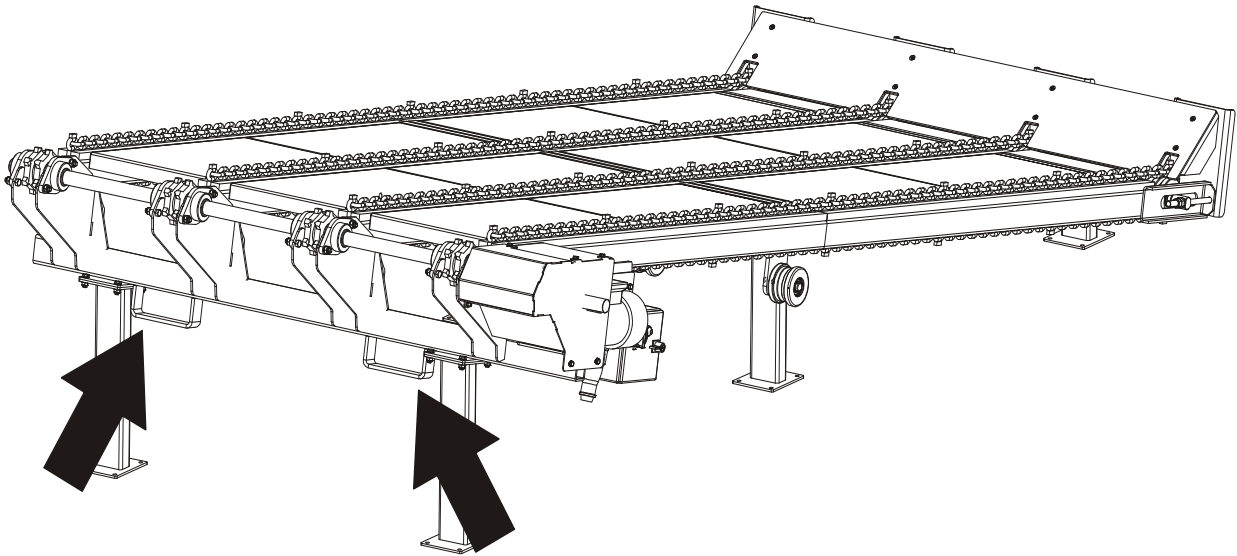

FIG. 2-2

2.3 Transfer Deck Operation

Use the START/STOP button on the electric box to turn on/off the Cross Transfer Deck. In case of any danger to persons or equipment, push the emergency stop button. This stops the transfer deck and the TVS. To release the stop, turn the emergency stop button clockwise. The machine will not restart until the emergency stop is released.

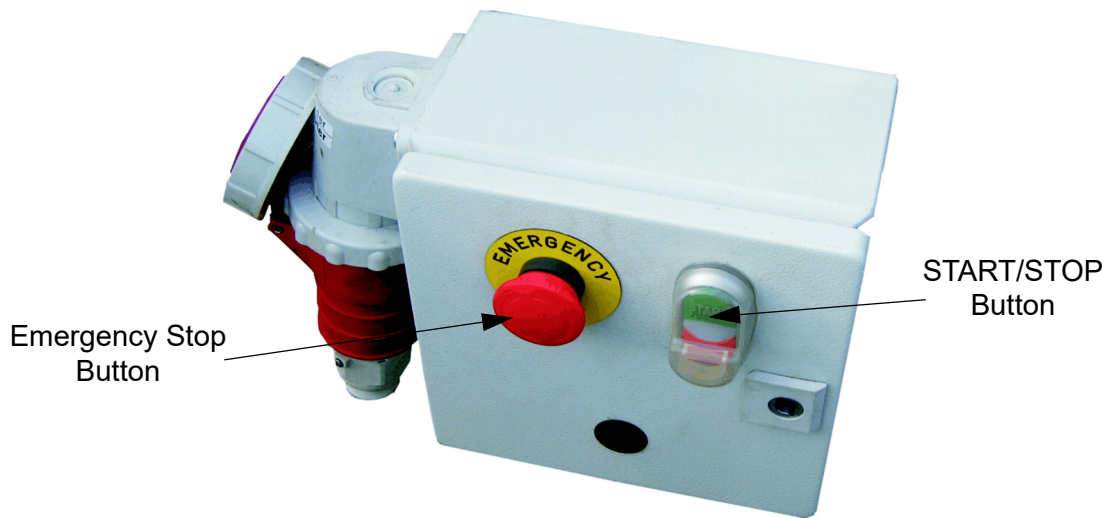



FIG. 2-3



CAUTION! If at any time you need to immediately stop the chain drive motor, press the emergency stop button located on the electric box.

2 OPERATION

Transfer Deck Operation

 **DANGER!** Be extremely careful when picking up the boards lying on the ground. The boards falling off the deck may hit the operator.

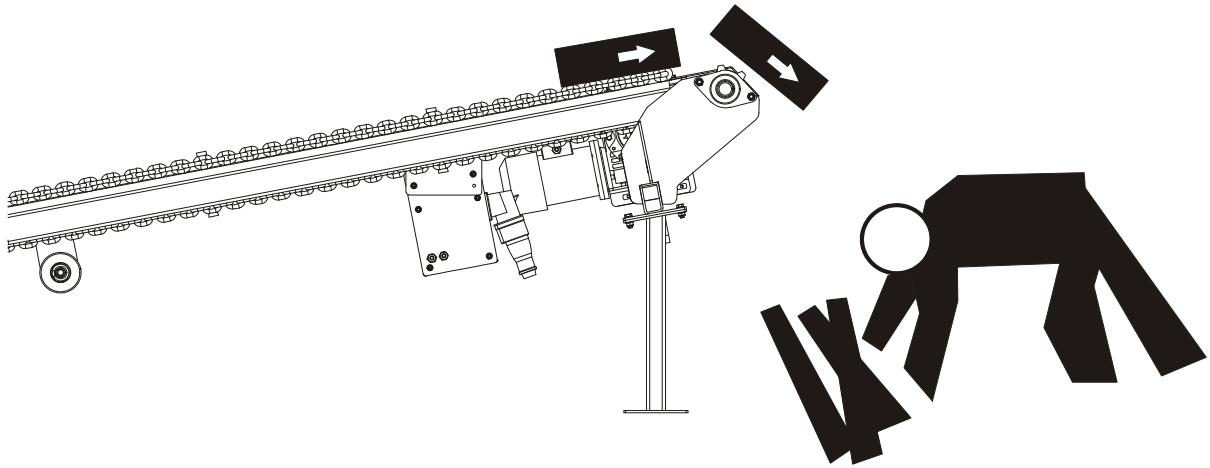

FIG. 2-4

SECTION 3 MAINTENANCE

This section lists the maintenance procedures that need to be performed.



This symbol identifies the interval (hours of operation) at which each maintenance procedure should be performed.

3.1 Lubrication



CAUTION! Never apply grease to the transfer chain. It causes sawdust buildup in chain links.



1. Using the grease fittings, lubricate the drive shaft bearings every 50 hours of operation.

See Figure 3-1.

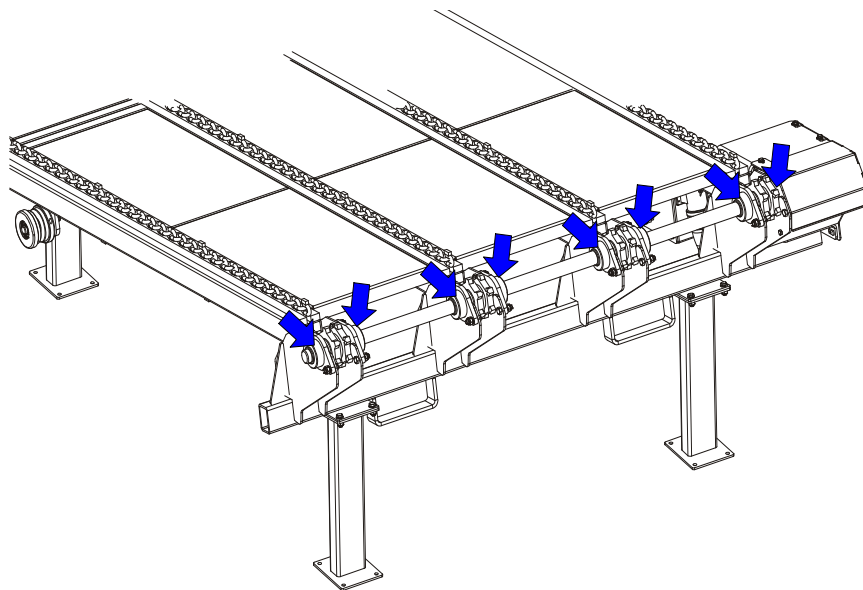

FIG. 3-1

2. Make sure all safety warning decals are readable. Remove sawdust and dirt. Replace any damaged or unreadable decals immediately. Order decals from your Wood-Mizer Customer Service Representative.

3.2 Transfer Chain Tension

Use the adjustment bolts shown below to adjust the transfer chain tension as necessary. The chain should lie freely on the guide bars.

CAUTION! Do not overtension the chains of TVS, Log Deck and Cross Transfer Deck. Overtensioning may lead to premature failure of the gear, bearings, rollers and chains.

See **Figure 3-2**. Adjust the transfer chain tension so that the chain lies freely on the support roller.

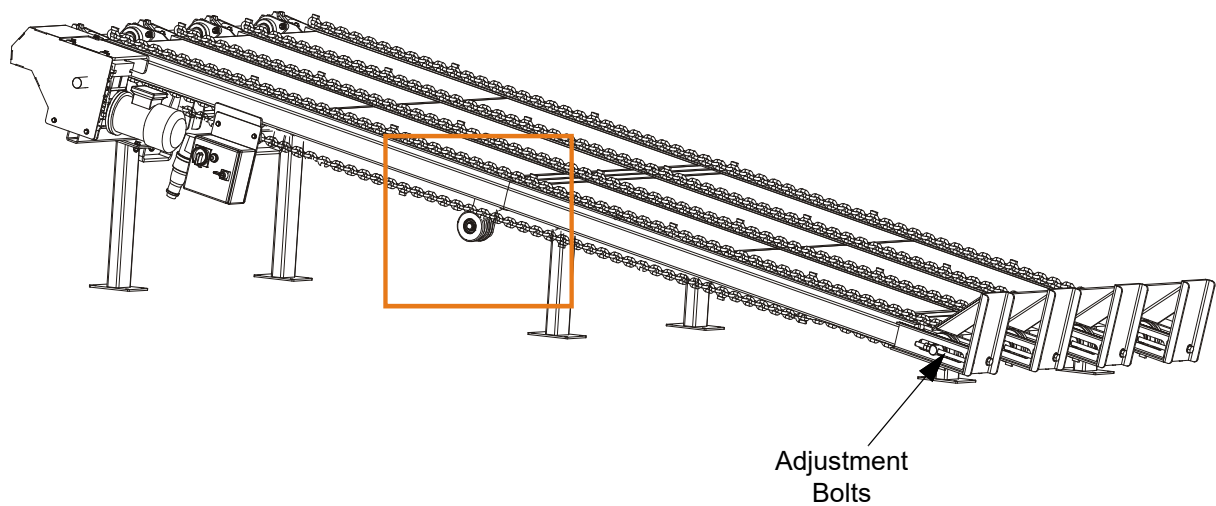

FIG. 3-2

3.3 Drive Chain Tension

Check tensions of the drive chains every 40 hours of operation and adjust as necessary. The chains should have approximately 1,5 cm of slack.

See Figure 3-3. Loosen the mounting bolts and move the motor along with the mounting plate in the direction indicated by the arrows.

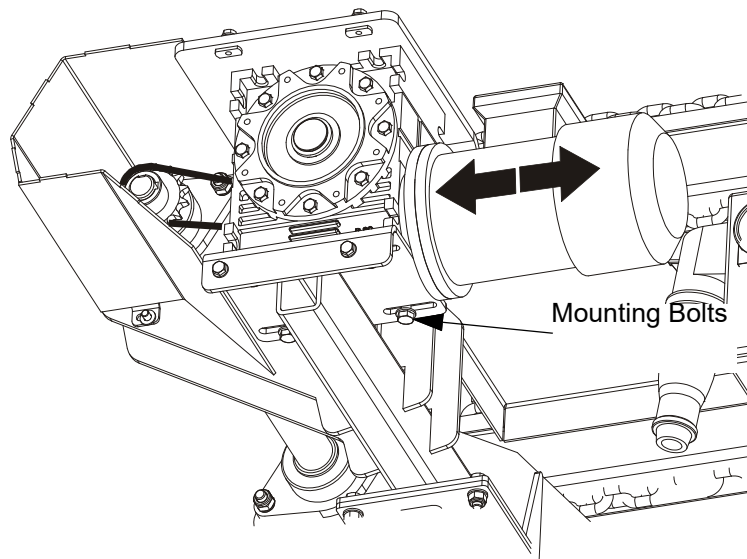

FIG. 3-3

SECTION 4 SPECIFICATIONS

4.1 Transfer Deck Dimensions

See Figure 4-1. The overall dimensions of the CC4 Cross Transfer Deck are shown below (all dimensions are in millimeters)

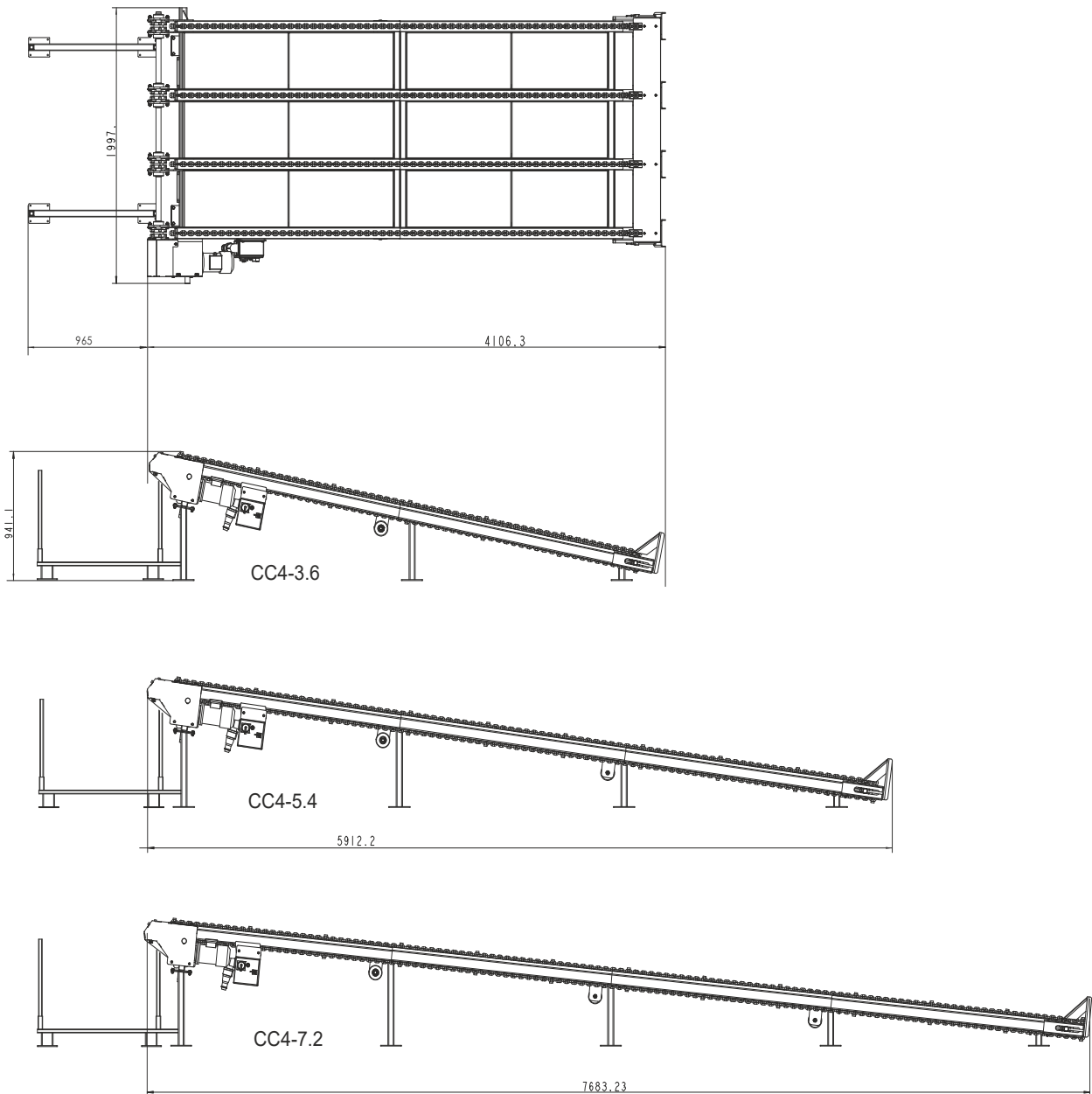

FIG. 4-1

See **Figure 4-2**. The figure below shows the overall dimensions of the CC4-3.6 WIDE Conveyor (all dimensions are in millimeters).

CC4_WIDE_DIMENSIONS
525976_MANUAL

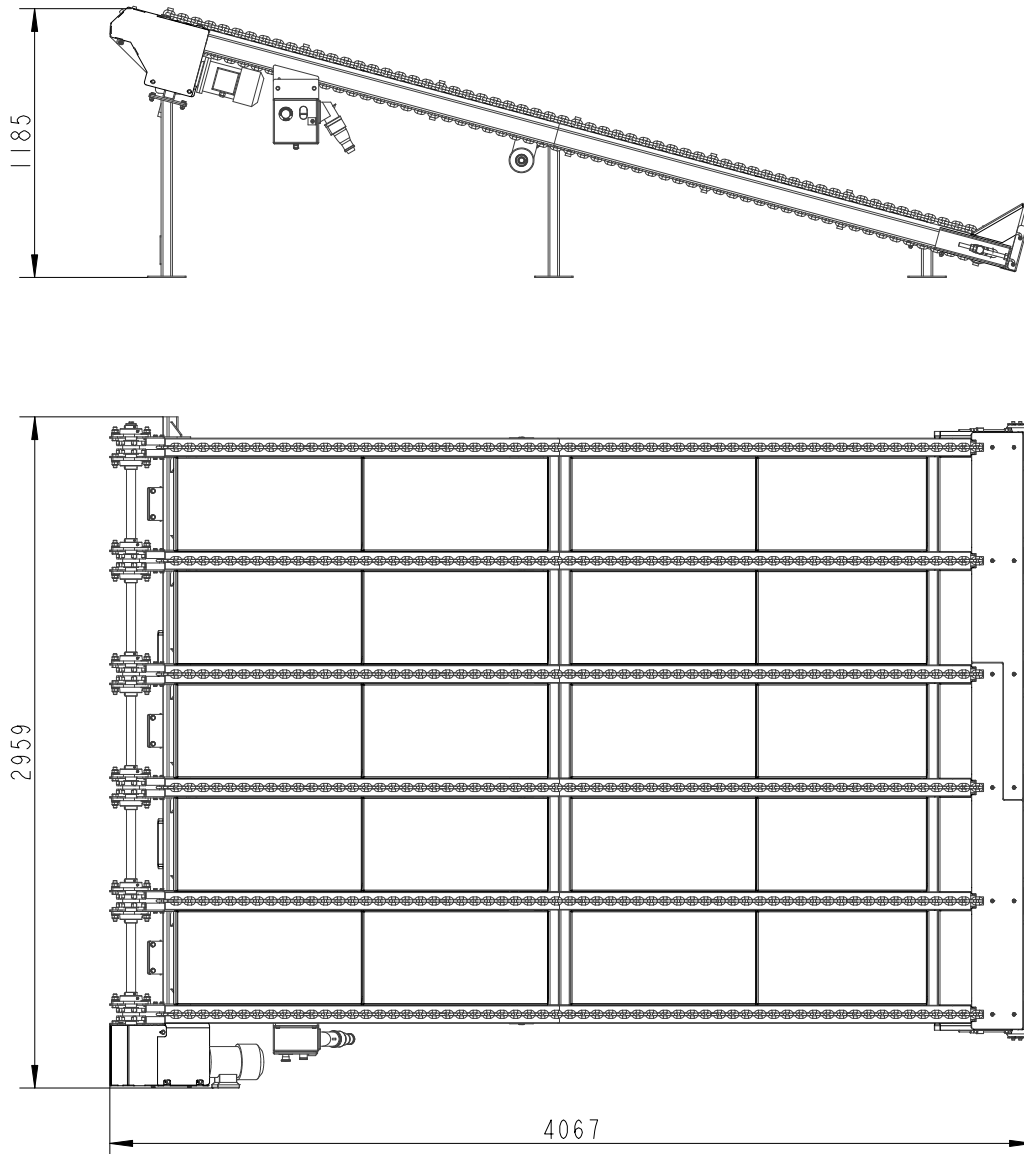

FIG. 4-2

4 SPECIFICATIONS

Transfer Deck Dimensions

See Table 4-1. See the table below for the weight of your CC4 Transfer Deck.

Weight	
	CC4-3.6 - 400 kg
	CC4-5.4 - 500 kg
	CC4-7.2 - 600 kg

TABLE 4-1

See Figure 4-3. The locations of anchor bolts for the CC4-3.6 Transfer Deck are shown below (all dimensions are in millimeters).

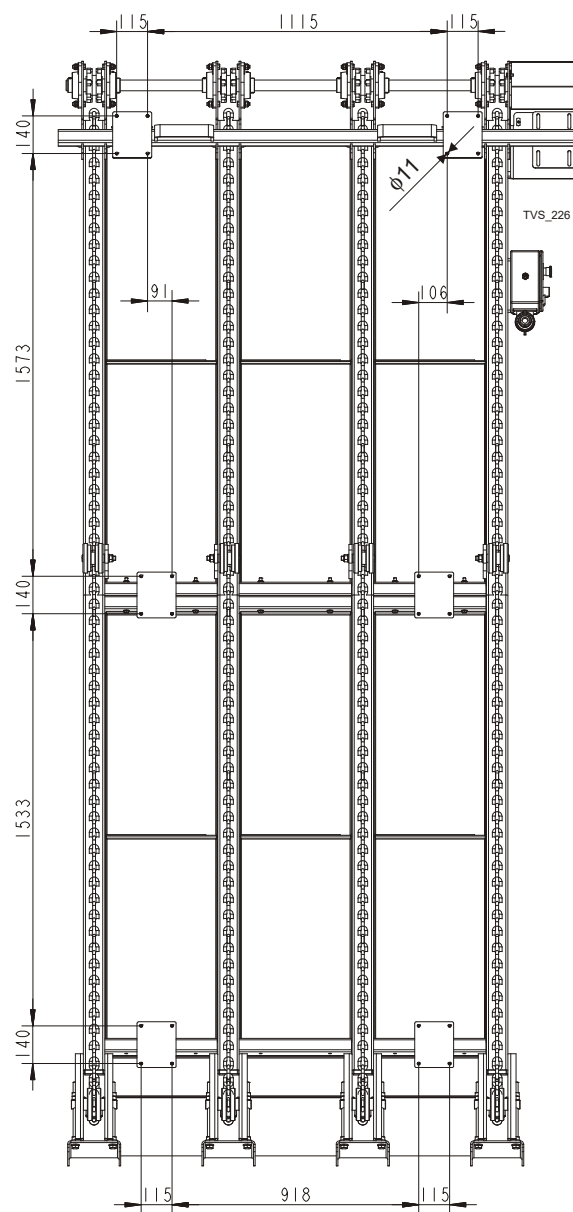

FIG. 4-3 CC4-3.6

See Figure 4-4. The locations of anchor bolts for the CC4-5.4 Transfer Deck are shown below (all dimensions are in millimeters).

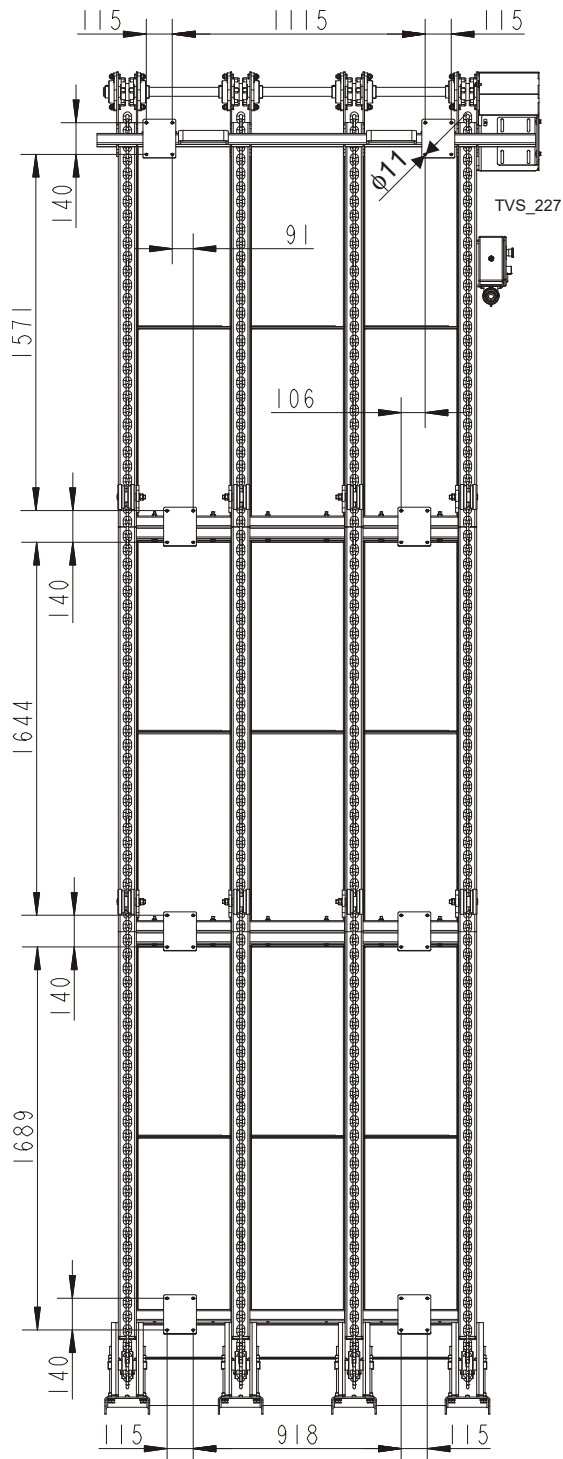

FIG. 4-4 CC4-5.4

4 SPECIFICATIONS

Transfer Deck Dimensions

See Figure 4-5. The locations of anchor bolts for the CC4-7.2 Transfer Deck are shown below (all dimensions are in millimeters).

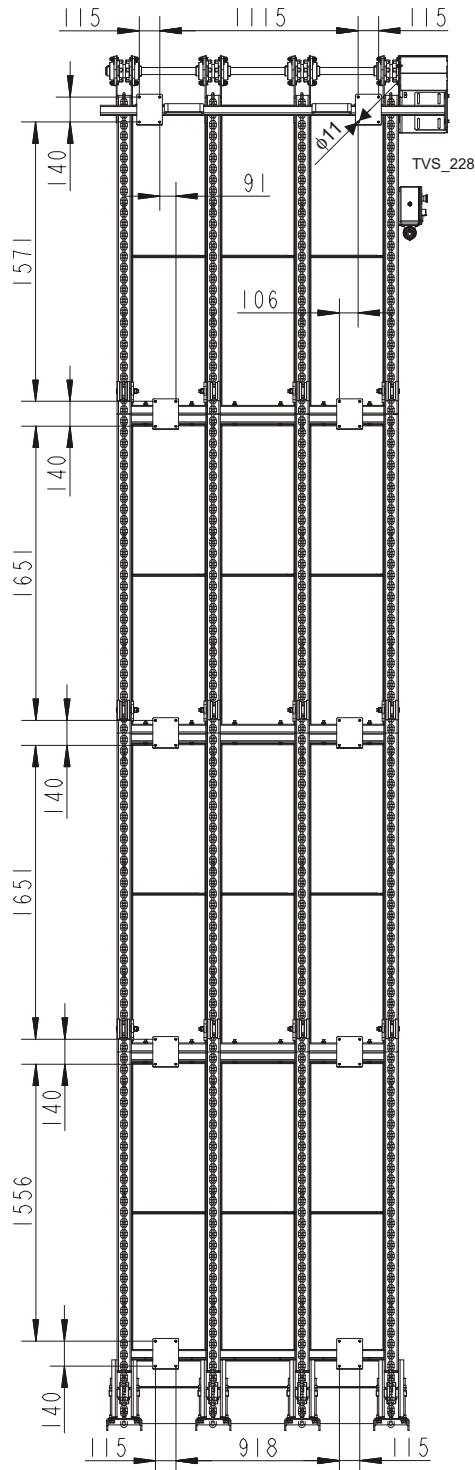

FIG. 4-5 CC4-7.2

See Figure 4-6. The locations of anchor bolts for the CC4-3.6 WIDE Conveyor are shown below (all dimensions are in millimeters).

CC4_WIDE_LEGS_DIMENSIONS
 525976_MANUAL

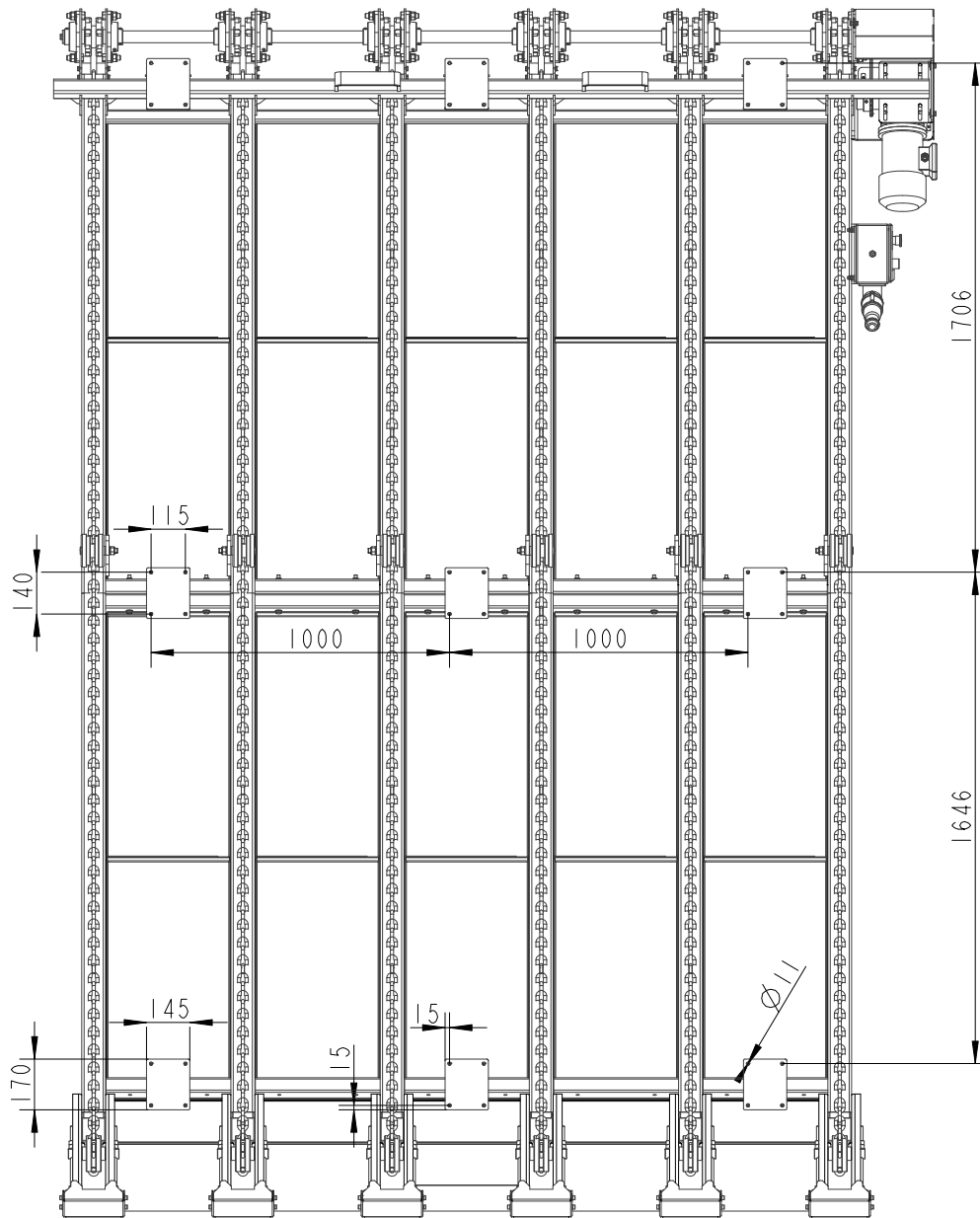

FIG. 4-6 CC4-3.6_WIDE

4 SPECIFICATIONS

Motor Specifications

4.2 Motor Specifications

See Table 4-2. See the table below for the chain drive motor specifications.

Motor Type	Manufacturer	Power	Other Data
SKh80X-4C1	Besel	1.1kW	1380 r.p.m. 3x230/400V, 50Hz

TABLE 4-2

SECTION 5 CROSS TRANSFER DECK

5.1 Front Module & Chains

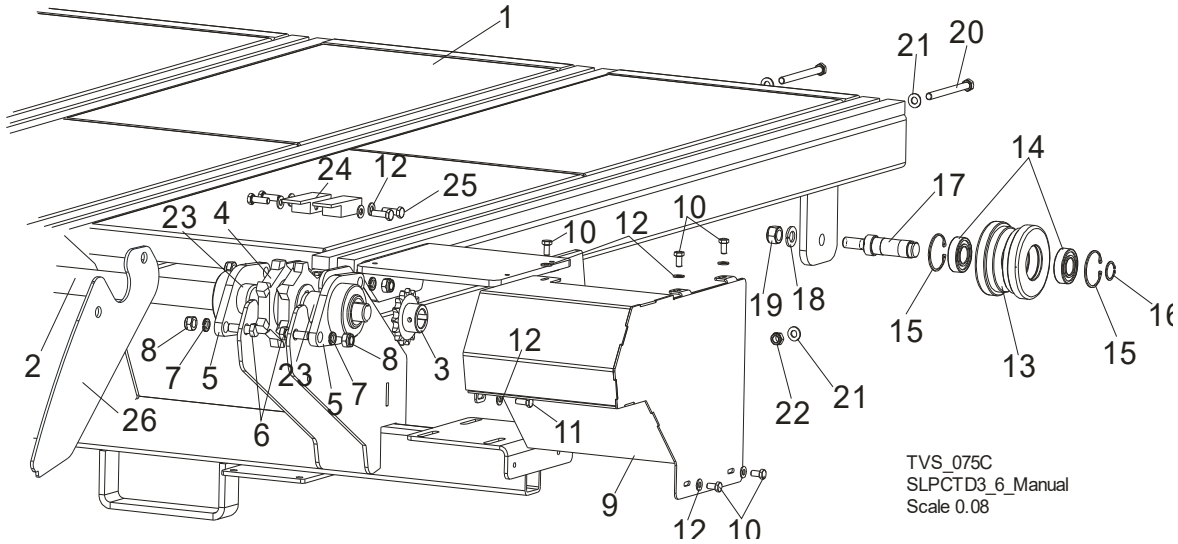

REF.	DESCRIPTION (◆ Indicates Parts Available In Assemblies Only)	PART #	QTY
	COMPLETE FRONT MODULE	099556	1
1	FRAME WELDMENT, CTD FRONT	097899-1	1
2	SHAFT, CTD DRIVE	097893	1
3	SPROCKET, 10B Z 15 INCLINE CONVEYOR	095162	1
4	SPROCKET, 16B 20Z	097657	4
5	BEARING, FYTB 40 KG	097898	8
6	BOLT, SPROCKET MOUNTING	091744	16
7	WASHER, 17 FLAT ZINC	F81058-1	16
8	NUT, M16 HEX NYLON ZINC LOCK	F81036-2	16
9	COVER, CTD CHAIN	097903-1	1
10	BOLT, M8X16-8.8 HEX HEAD ZINC	F81002-20	5
11	BOLT, M8X20-8.8-B HEX HEAD FULL THREAD ZINC	F81002-4	1
12	WASHER, 8.4 FLAT, ZINC	F81054-1	22
	WHEEL, CTD COMPLETE	098492	4
13	TENSIONER, CTD CHAIN	098493	1
14	BEARING, SKF 6205-2RS ROLLER	087353	2
15	RING, W52 INSIDE RETAINING	F81090-6	2
16	RING, 25Z OUTSIDE RETAINING	F81090-22	1
17	SHAFT, CTD CHAIN TENSIONER	098494	1
18	WASHER, 16.3 SPLIT LOCK ZINC	F81058-2	4
19	NUT, M16-8 HEX NYLON ZINC LOCK	F81036-2	4
20	BOLT, M10x125-8.8 HEX HEAD ZINC	F81003-18	6
21	WASHER, 10.5 FLAT ZINC	F81055-1	12
22	NUT, M10-8-B HEX NYLON ZINC LOCK	F81033-1	6
23	BUSHING, FI 40 x FI 48x14 SPACER	099958-1	8
24	BAR, FLAT	508973-1	8
25	BOLT, M8X25-8.8-B HEX HEAD FULL THREAD	F81002-5	16

26	PLATE AXIS CTD	509282-1	1 ¹	
	CHAIN, SLPCTD3.6 ZINC-PLATED	099310	4	
	CHAIN, SLPCTD5.4	099571	4	
	CHAIN, CTC7.2	099572	4	

¹ Option

5.2 Central Module

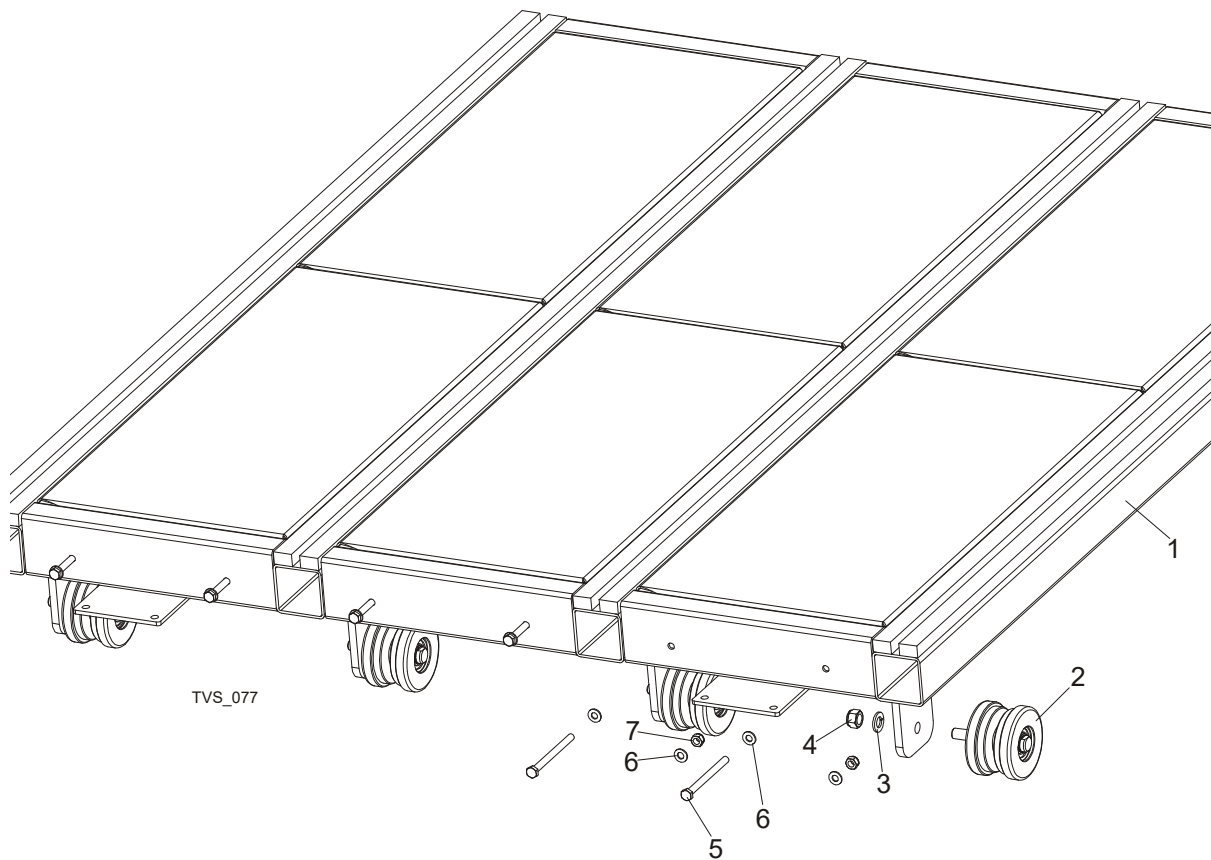

REF.	DESCRIPTION (◆ Indicates Parts Available In Assemblies Only)	PART #	QTY
	COMPLETE CENTRAL MODULE	099557	1/2 ¹
1	MODULE, CTD CENTRAL PAINTED	098125-1	1
2	WHEEL, CTD COMPLETE	098492	4
3	WASHER, 16.3 SPLIT LOCK ZINC	F81058-2	4
4	NUT, M16-8 HEX NYLON ZINC LOCK	F81036-2	4
5	BOLT, M10x125-8.8 HEX HEAD ZINC	F81003-18	6
6	WASHER, 10.5 FLAT ZINC	F81055-1	12
7	NUT, M10-8-B HEX NYLON ZINC LOCK	F81033-1	6

¹ Used on CTD5.4 - 1 piece and on CTD7.2 - 2 pieces.

5.3 Rear Module

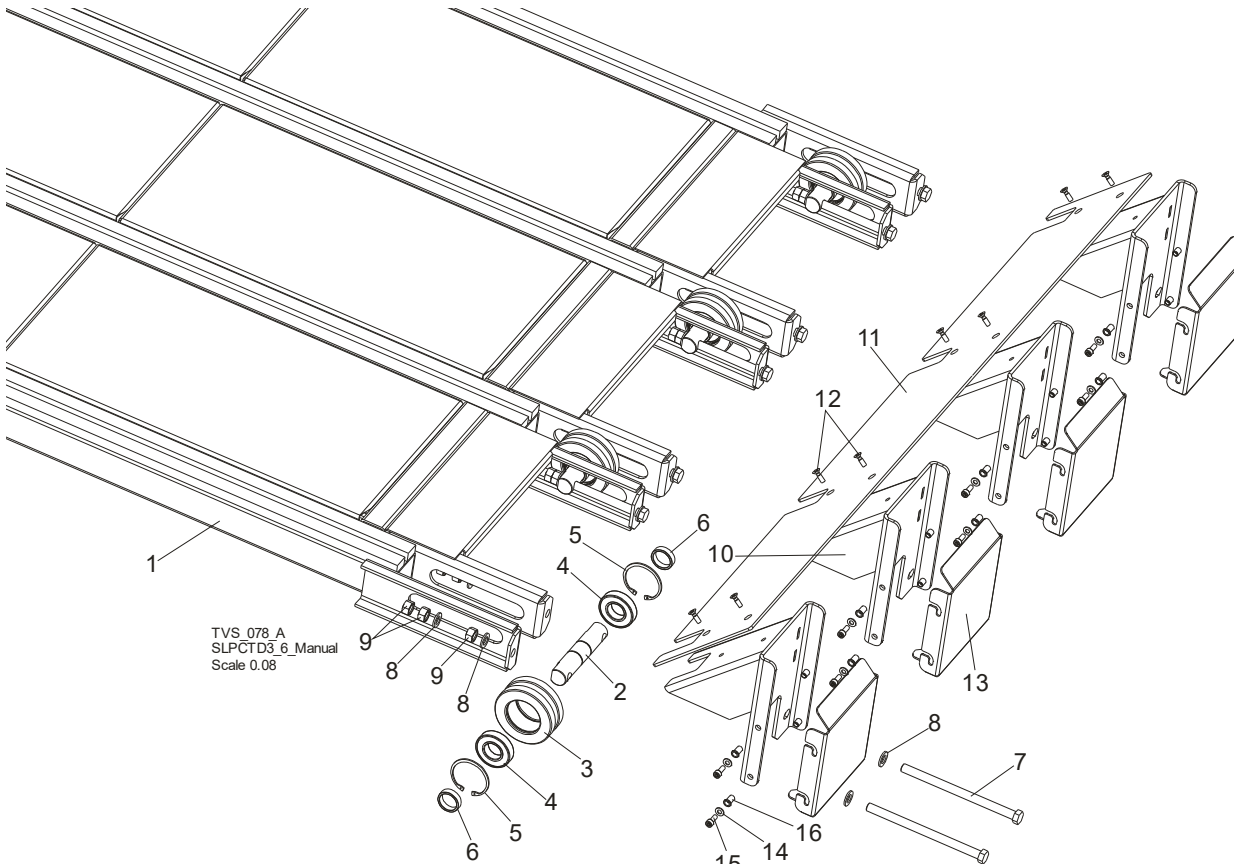

REF.	DESCRIPTION (◆ Indicates Parts Available In Assemblies Only)	PART #	QTY
	COMPLETE REAR MODULE	099558	1
1	FRAME WELDMENT, CTD REAR PTD	097900-1	1
	COMPLETE CHAIN TENSION WHEEL	097655	4
2	SHAFT, CHAIN TENSION WHEEL	096207-1	1
3	WHEEL, TVS CHAIN TENSION	096208-1	1
4	BEARING, 6207-2RS, C3, 35X72X17	014811	2
5	RING, W72 INSIDE RETAINING	F81090-4	2
6	BUSHING, FI 36x FI 44x22 SPACER ZINC	099959-1	8
7	BOLT, M16X240-8.8-A2 FULL THREAD	F81006-29	8
8	WASHER, 17 FLAT ZINC	F81058-1	24
9	NUT, M16-5.8 HEX ZINC	F81036-1	24
	BUMPER ASSEMBLY	099560-1	1
10	BRACKET, BUMPER MOUNTING	098223-1	4
11	PLATE, CTD BUMPER	098496-1	1
12	SCREW, M8X25 CROSS RECESSED COUNTERSUNK HEAD	F81002-51	8
13	PLATE, BUMPER	512626-1	4
14	WASHER, 8.4 FLAT ZINC	F81054-1	16
15	SCREW, M8 X 20-8.8 HEX SOCKET HEAD CAP ZINC	F81002-30	16
16	NUT, M8 1.0-2.5 FTR-Z FE/ZN5 RIVET	F81032-9	16

5.5 Leg Kits

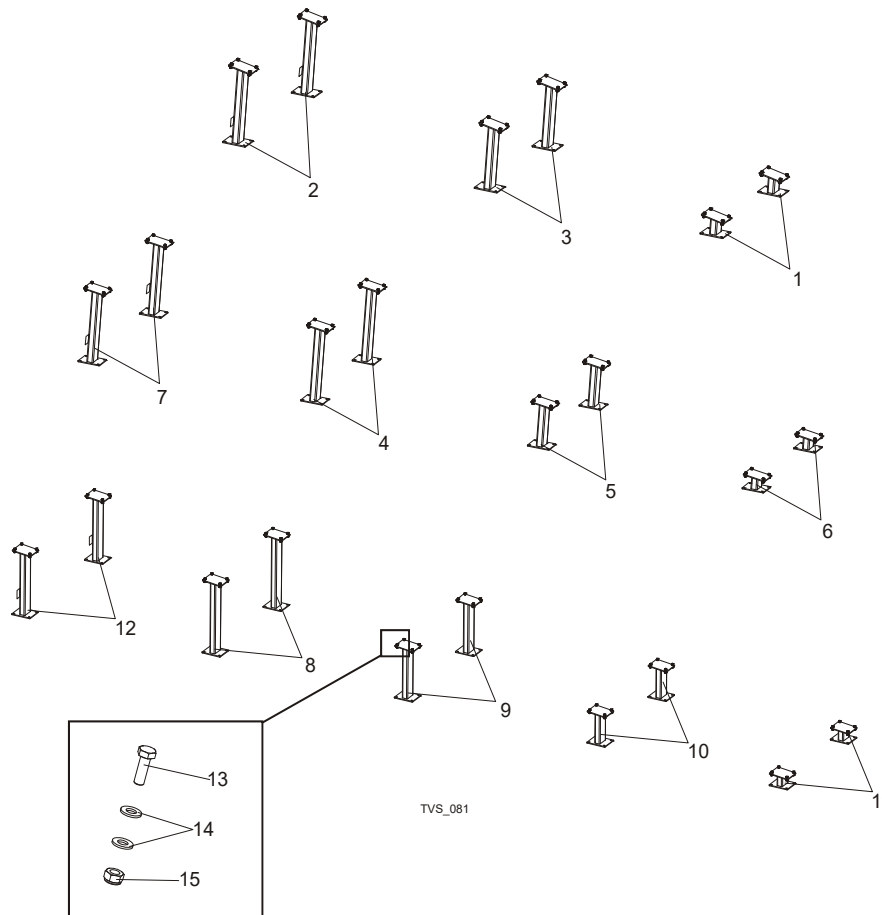

REF.	DESCRIPTION (◆ Indicates Parts Available In Assemblies Only)	PART #	QTY
	LEG KIT, CTD SHORT	099554	1
1	LEG, 7.6M REAR PTD	099279-1	2
2	LEG, FRONT PTD	099415-1	2
3	LEG, REAR PTD	099416-1	2
	LEG KIT, CTD MEDIUM	099568	1
4	LEG, CTD5.4 MIDDLE PTD (1)	099573-1	2
5	LEG, CTD5.4 MIDDLE PTD (2)	099574-1	2
6	LEG, CTD5.4 REAR PTD	099575-1	2
7	LEG, CTD5.4 FRONT PTD	099576-1	2
	LEG KIT, CTD LONG	099553	1
8	LEG, CTD7.2 MIDDLE PTD (1)	099277-1	2
9	LEG, CTD7.2 MIDDLE PTD (2)	099278-1	2
10	LEG, CTD7.2 MIDDLE PTD (3)	099562-1	2
11	LEG, CTD7.2 REAR PTD	099564-1	2
12	LEG, CTD7.2 FRONT PTD	099566-1	2
13	BOLT, M10x30-5.8 HEX HEAD FULL THREAD ZINC	F81003-2	24/32/40
14	WASHER, 10.5 FLAT ZINC	F81055-1	48/64/80
15	NUT, M10-8-B HEX NYLON ZINC LOCK	F81033-1	24/32/40

5.6 Slabs Table

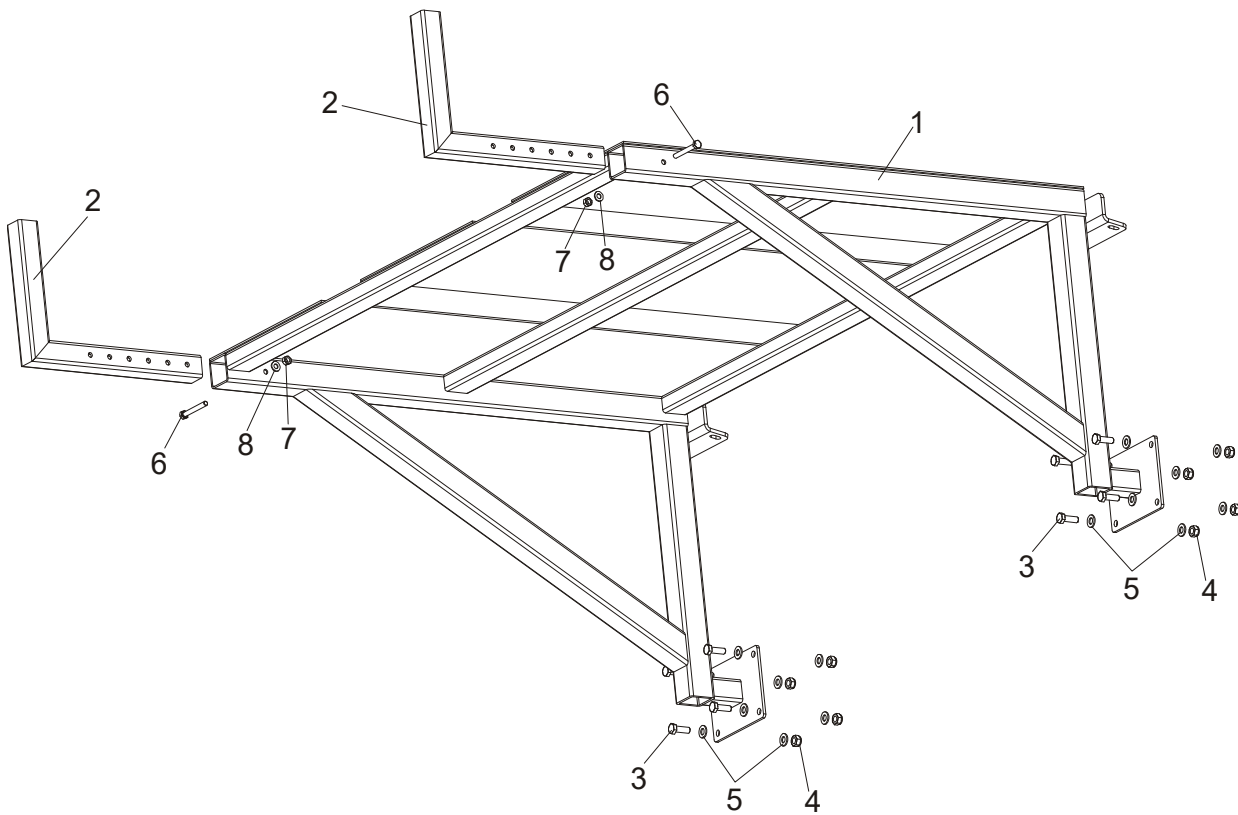

REF.	DESCRIPTION (◆ Indicates Parts Available In Assemblies Only)	PART #	QTY
1	TABLE, SLPCTD HIGH	100517-1	1
2	ARM, TABLE LOCK	100531-1	2
3	BOLT, M10X30-5.8 HEX HEAD FULL THREAD	F81003-2	8
4	NUT, M10-8-B NYLON HEX ZINC LOCK	F81033-1	16
5	WASHER, 10.5 FLAT ZINC	F81055-1	8
6	BOLT, M8X65 8.8 HEX HEAD ZINC	F81002-9	2
7	NUT, M8-8-B HEX ZINC	F81032-1	2
8	WASHER, 8.4 FLAT ZINC	F81054-1	2

5.7 Decals

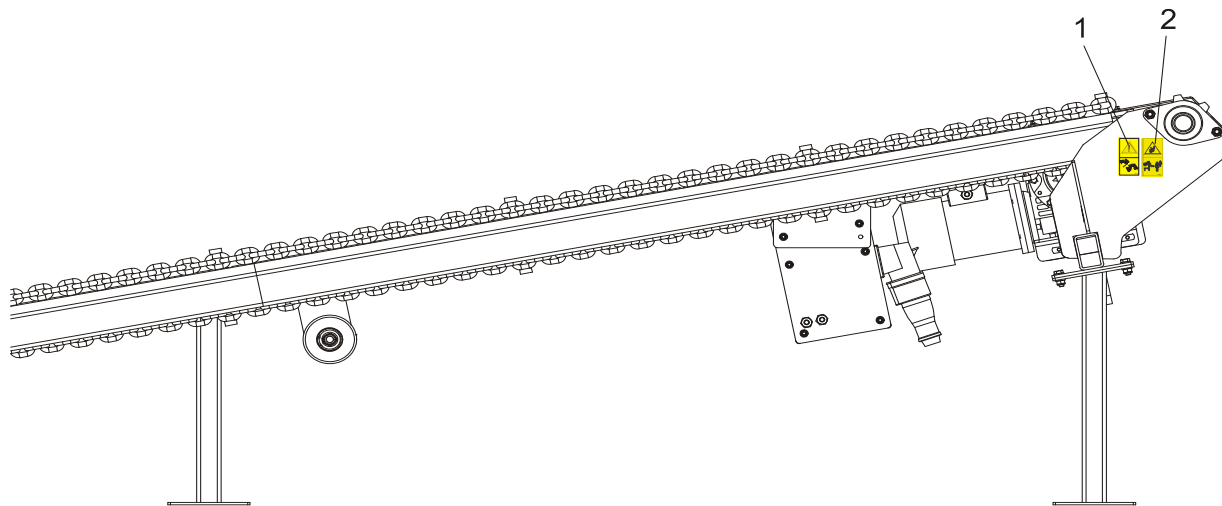
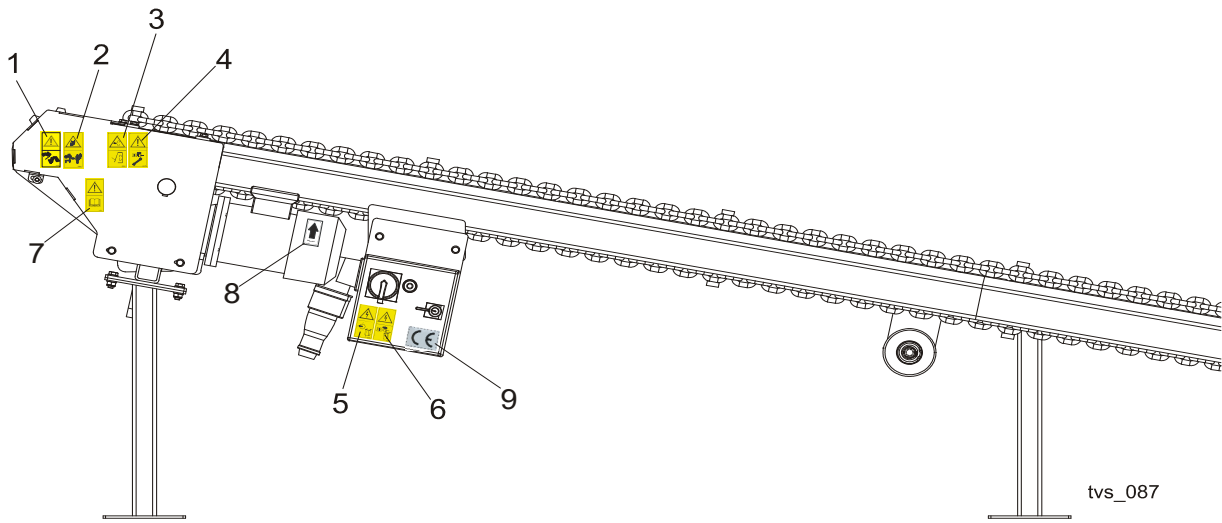

REF.	DESCRIPTION (◆ Indicates Parts Available In Assemblies Only)	PART #	QTY
	DECALS KIT, PICTOGRAMS, CROSS TRANSFER DECK	099835	1
1	DECAL, LOOK OUT FOR THE FALLING SLABS (PICTOGRAM)	099780	2
2	DECAL, KEEP AWAY WARNING (PICTOGRAM)	099221	2
3	DECAL, CLOSE ALL GUARDS AND COVERS BEFORE STARTING THE MACHINE	099220	1
4	DECAL, DISCONNECT AND LOCK OUT POWER SUPPLY BEFORE SERVICING (PICTOGRAM)	098177	1
5	DECAL, HIGH VOLTAGE INSIDE THE ELECTRIC BOX (PICTOGRAM)	096316	1
6	DECAL, REMOVE THE PLUG BEFORE OPENING THE BOX (PICTOGRAM)	096319	1
7	DECAL, READ OPERATOR'S MANUAL (PICTOGRAM)	096317	1
8	DECAL, 1400 RPM MOTOR DIRECTION	S20097H	1
9	DECAL, CE- CERTIFIED SAWMILL	P85070	1

SECTION 6 CC4-3_6C-UL

6.1 Cross Transfer Deck CC4-3_6C-UL

CC4-3_6C-UL_001
CC4-3_6C-UL

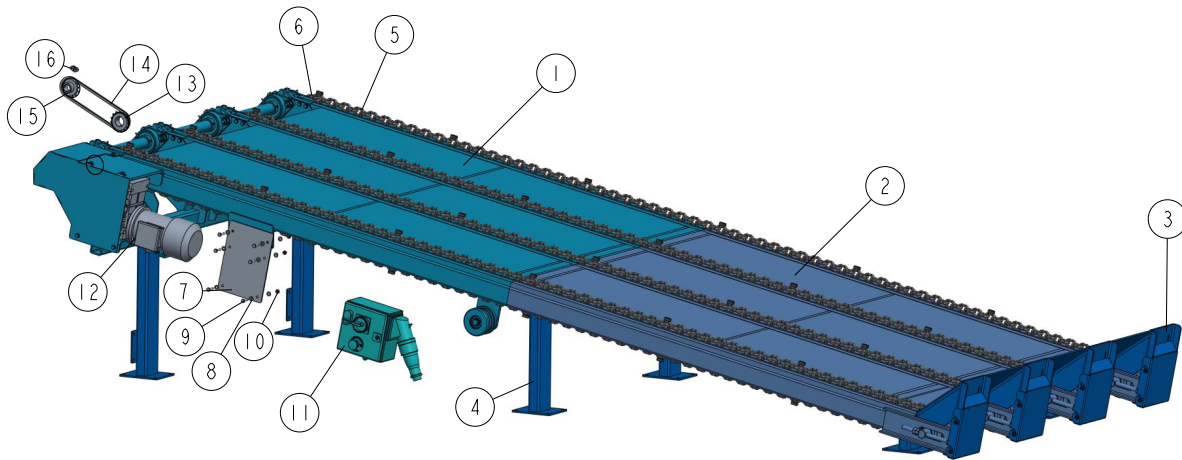

REF	DESCRIPTION (◆ indicates parts available in assemblies only)	PART #	QTY
-	CROSS TRANSFER DECK	CC4-3_6C-UL	1
1	COMPLETE FRONT MODULE See Section 6.2	099556	1
2	COMPLETE REAR MODULE See Section 6.3	099558	1
3	STOP ASSEMBLY, SLAB See Section 6.4	099560	1
4	LEG KIT, CTD SHORT See Section 6.6	099554	1
5	CHAIN, SLPCTD3.6 ZINC-PLATED	099310	4
6	LINK, CHAIN MASTER	098661	4
7	PANEL, CTD ELECTRIC BOX	099550-1	1
8	WASHER, 8.4 FLAT ZINC	F81054-1	12
9	BOLT, M8X30 8.8 HEX HEAD FULL THREAD ZIN	F81002-7	6
10	NUT, M8-8-B HEX NYLON LOCK ZINC	F81032-2	6
11	ELECTRIC BOX CC4_C-UL See Section 6.5	507253-UL	1
12	MOTOREDUCER, MR-80/64/1.1-1400/K3/V6 UL	098663-UL	1
13	SPROCKET, 10B Z15 T75122	099935	1
14	CHAIN, 10B-48PZ	099781	1
15	SPROCKET, 10B Z 15 INCLINE CONVEYOR	095162	1
16	LINK, REDUCER LP4 R1-15,875X9,65	089405	1

6.2 Front Module 099556

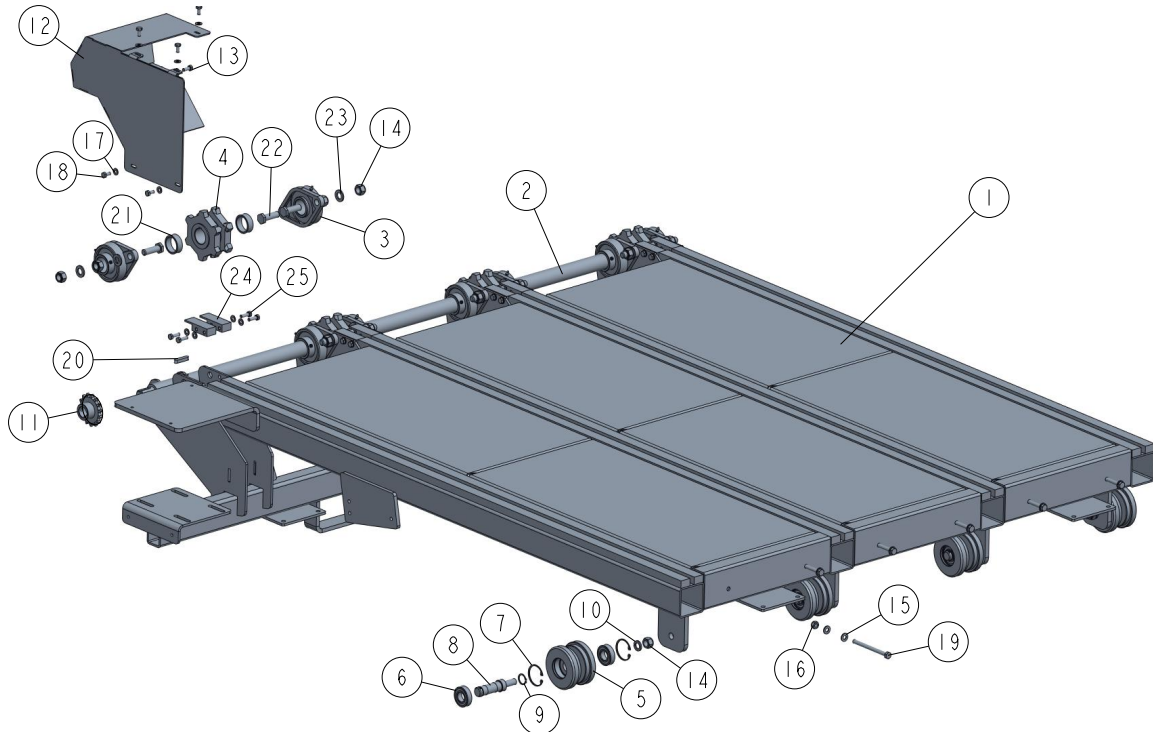
099556_001
099556

REF	DESCRIPTION (◆ indicates parts available in assemblies only)	PART #	QTY
-	COMPLETE FRONT MODULE	099556	1
1	FRAME WELDMENT, CTD FRONT	097899-1	1
2	SHAFT, CTD DRIVE	097893	1
3	BEARING, UCFL208 W/HOUSING	099423	8
4	SPROCKET, 16B 20Z	097657	4
-	WHEEL, CTD COMPLETE	098492	4
5	TENSIONER, CTD CHAIN	098493	1
6	BEARING, 6205 2RSR P6 (FAG,NSK,SKF) BALL	087353	2
7	RING, W52 INSIDE RETAINING	F81090-6	2
8	SHAFT, CTD CHAIN TENSIONER	098494	1
9	RING, 25Z OUISSIDE RETAINING	F81090-22	1
10	WASHER, 16.3 SPLIT LOCK ZINC	F81058-2	4
11	SPROCKET, 10B Z 15 INCLINE CONVEYOR	095162	1
12	COVER, CTD CHAIN	097903-1	1
13	BOLT, M8X20-8.8-B HEX HEAD FULL THREAD Z	F81002-4	1
14	NUT, M16-8 HEX NYLON ZINC LOCK	F81036-2	20
15	WASHER, 10.5 FLAT ZINC	F81055-1	12
16	NUT, M10-8-B NYLON HEX ZINC LOCK	F81033-1	6
17	WASHER, 8.4 FLAT ZINC	F81054-1	22
18	BOLT, M8X16-8.8-B HEX HEAD FULL THREAD Z	F81002-20	5
19	BOLT, M10X125 8.8 HEX HEAD ZINC	F81003-18	6
20	KEY, A10X8X45 PARALLEL	091312	4

REF	DESCRIPTION (◆ indicates parts available in assemblies only)	PART #	QTY	
21	BUSHING, FI 40 X FI 48X14 SPACER	099958-1	8	
22	BOLT, SPROCKET MOUNTING	091744	16	
23	WASHER, 17 SPLIT LOCK ZINC	F81058-1	16	
24	BAR, FLAT	508973-1	8	
25	BOLT, M8 X 25-8.8-B HEX HEAD FULL THREAD	F81002-5	16	

6.3 Rear Module 599558

099558_001
099558

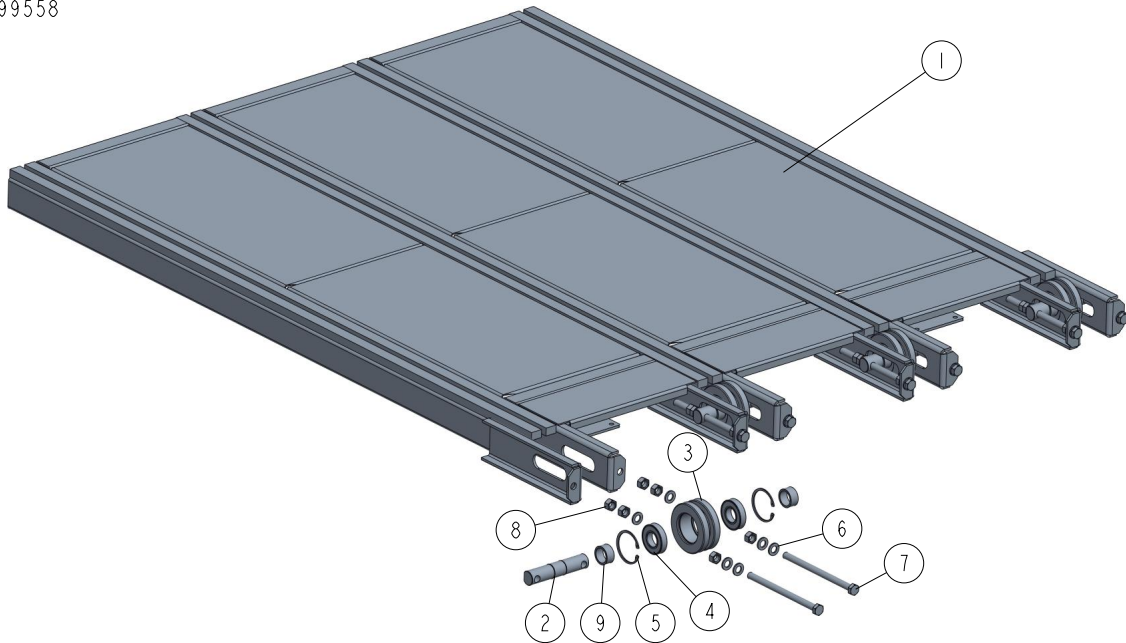

REF	DESCRIPTION (◆ indicates parts available in assemblies only)	PART #	QTY	
-	COMPLETE REAR MODULE	099558	1	
1	FRAME WELDMENT, CTD REAR PTD	097900-1	1	
2	SHAFT, CHAIN TENSION WHEEL	096207-1	4	
-	COMPLETE CHAIN TENSION WHEEL	097655	4	
3	WHEEL, TVS CHAIN TENSION	096208-1	1	
4	BEARING, 6207 2RS 35X72X17 FAG	014811	2	
5	RING, W72 INSIDE RETAINING	F81090-4	2	
6	WASHER, 17 SPLIT LOCK ZINC	F81058-1	24	
7	BOLT, ISO 4017-M16X240-8.8-A2E HEX HEAD	F81006-29	8	
8	NUT, M16-5.8 HEX ZINC	F81036-1	24	
9	BUSHING, FI 36X FI 44X22 SPACER ZINC	099959-1	8	

6.4 Slab Stop Assembly 099560

099560_001
099560

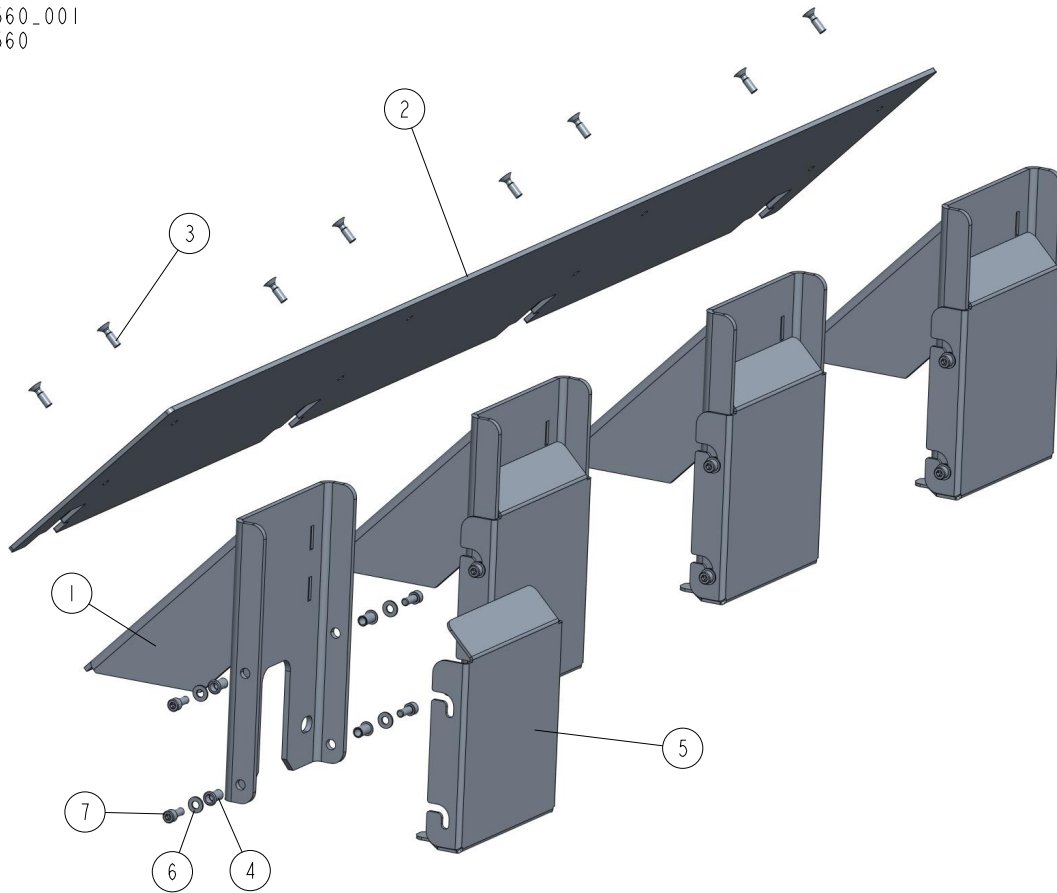

REF	DESCRIPTION (◆ indicates parts available in assemblies only)	PART #	QTY
-	STOP ASSEMBLY, SLAB	099560	1
1	BRACKET, BUMPER MOUNTING	098223-1	4
2	PLATE, CTD BUMPER	098496-1	1
3	BOLT, M8X25 PAN HEAD ZINC	F81002-51	8
4	NUT, M8 1.0-2.5 FTR-Z RIVET ZINC	F81032-9	16
5	PLATE, BUMPER	512626-1	4
6	WASHER, 8.4 FLAT ZINC	F81054-1	16
7	SCREW, M8X20-8.8 HEX SOCKET HEAD CAP ZIN	F81002-30	16

6.5 Electric Box CC4_C-UL. 507253-UL

507253-UL_001
507253-UL

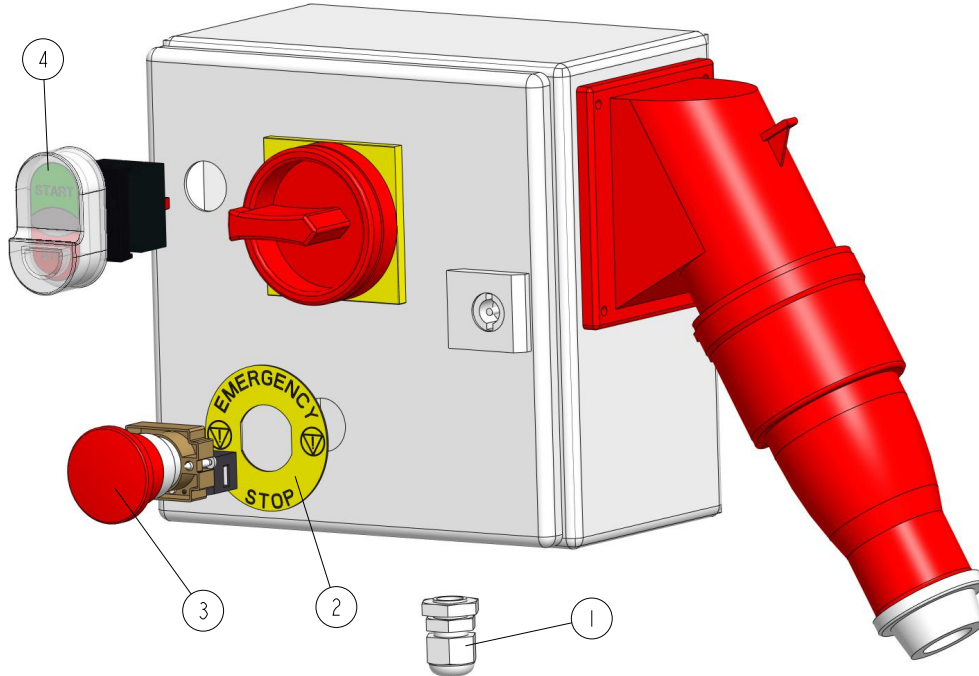

REF	DESCRIPTION (◆ indicates parts available in assemblies only)	PART #	QTY
-	BOX ASSEMBLY, ELECTRIC CC4_C-UL	507253-UL	1
1	GLAND, DP9/H CABLE	F81096-2	1
2	WASHER, ZBY9330 EMERGENCY STOP BUTTON	086561	1
3	BUTTON, XB4 BS542 EMERGENCY STOP	086556	1
4	BUTTON, 24V START/STOP	090452	1

6.6 Leg Kits 099554

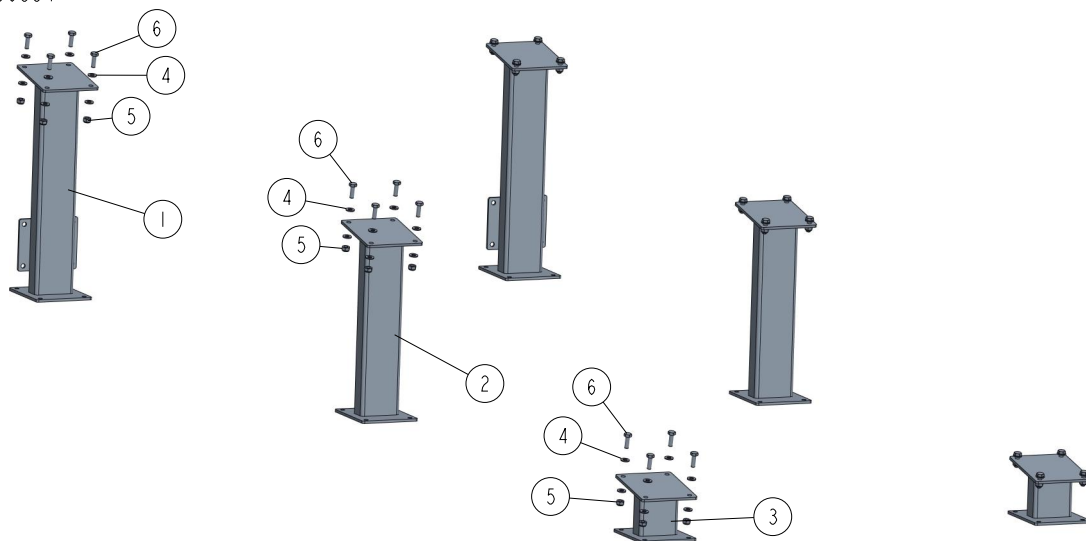
099554_001
099554

REF	DESCRIPTION (◆ indicates parts available in assemblies only)	PART #	QTY
-	LEG KIT, CTD SHORT	099554	1
1	LEG, FRONT PTD	099415-1	2
2	LEG, REAR PTD	099416-1	2
3	LEG, 7.6M REAR PTD	099279-1	2
4	WASHER, 10.5 FLAT ZINC	F81055-1	48
5	NUT, M10-8-B NYLON HEX ZINC LOCK	F81033-1	24
6	BOLT, M10X1.25X25-8.8-A HEX HEAD FULL TH	F81003-2	24

SECTION 7 CC4-WIDE-SLP2-001 CHAIN CONVEYOR

7.1 Chain Conveyor

525976_001
525976_MANUAL

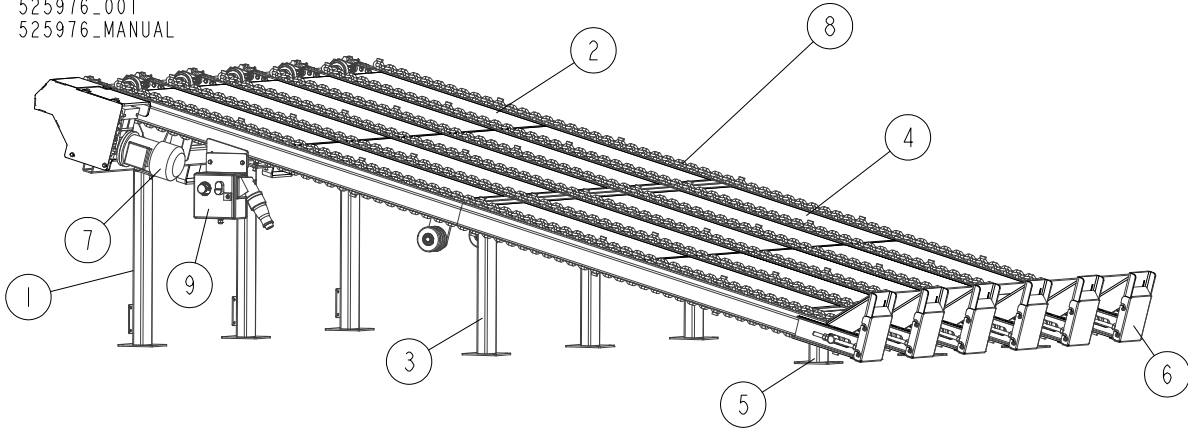

REF.	DESCRIPTION (◆ Indicates Parts Available In Assemblies Only)	PART #	QTY
-	CONVEYOR, CHAIN	525976	1
1	LEG, CHAIN CONVEYOR FRONT See Section 7.2	525971-1	3
2	MODULE, CHAIN CONVEYOR FRONT See Section 7.5	525962	1
3	LEG, CHAIN CONVEYOR MIDDLE See Section 7.3	525975-1	3
4	MODULE, CHAIN CONVEYOR REAR See Section 7.6	525965	1
5	LEG, CHAIN CONVEYOR REAR See Section 7.4	525973-1	3
6	STOP, SLAB See Section 7.7	525967	1
7	MOTOR KIT See Section 7.8	525985	1
8	CHAIN, SLPCTD 3.6 CONVEYOR	099310	6
9	BOX ASSEMBLY, ELECTRIC See Section 7.9	526207	1

7 CC4-WIDE-SLP2-001 Chain Conveyor

Front Leg

7.2 Front Leg

525971-1_001
525971-1_MANUAL

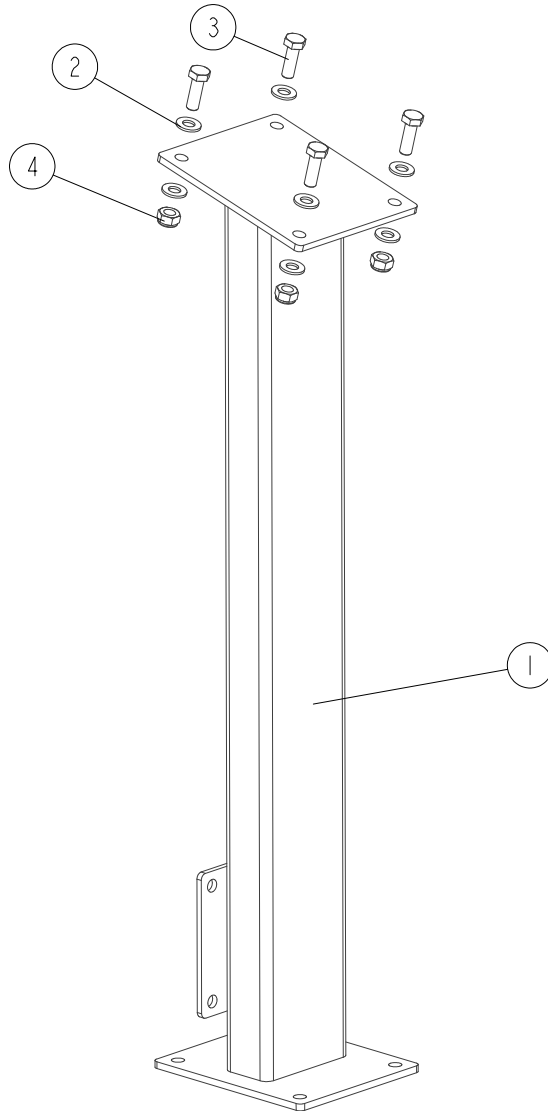

REF.	DESCRIPTION (◆ Indicates Parts Available In Assemblies Only)	PART #	QTY
1	LEG, CHAIN CONVEYOR FRONT	525971-1	1
2	WASHER, 10.5 FLAT ZINC	F81055-1	8
3	BOLT, M10X30-8.8 HEX HEAD FULL THREAD ZINC	F81003-2	4
4	NUT, M10-8-B HEX NYLON ZINC LOCK	F81033-1	4

7.3 Middle Leg

525975-1_001
525975-1_MANUAL

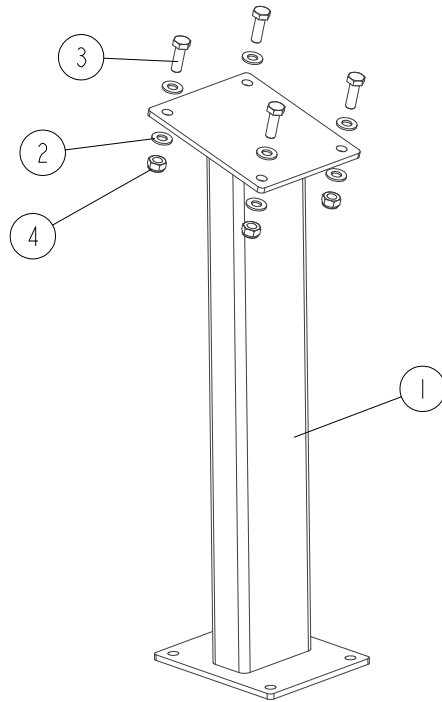

REF.	DESCRIPTION (◆ Indicates Parts Available In Assemblies Only)	PART #	QTY	
1	LEG, CHAIN CONVEYOR MIDDLE	525975-1	1	
2	WASHER, 10.5 FLAT ZINC	F81055-1	8	
3	BOLT, M10X30-8.8 HEX HEAD FULL THREAD ZINC	F81003-2	4	
4	NUT, M10-8-B HEX NYLON ZINC LOCK	F81033-1	4	

7.4 Rear Leg

525973-1_001
525973-1_MANUAL

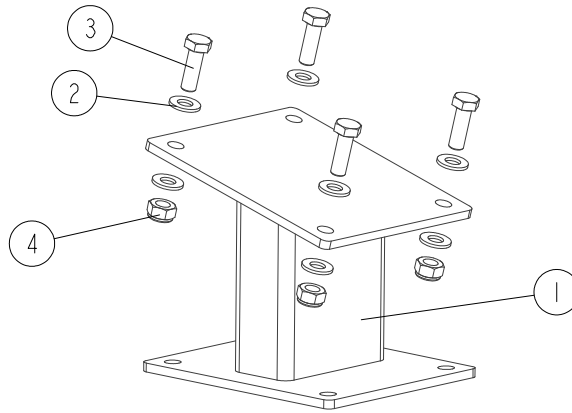

REF.	DESCRIPTION (◆ Indicates Parts Available In Assemblies Only)	PART #	QTY	
1	LEG, CHAIN CONVEYOR REAR	525973-1	1	
2	WASHER, 10.5 FLAT ZINC	F81055-1	8	
3	BOLT, M10X30-8.8 HEX HEAD FULL THREAD ZINC	F81003-2	4	
4	NUT, M10-8-B HEX NYLON ZINC LOCK	F81033-1	4	

7.5 Front Module

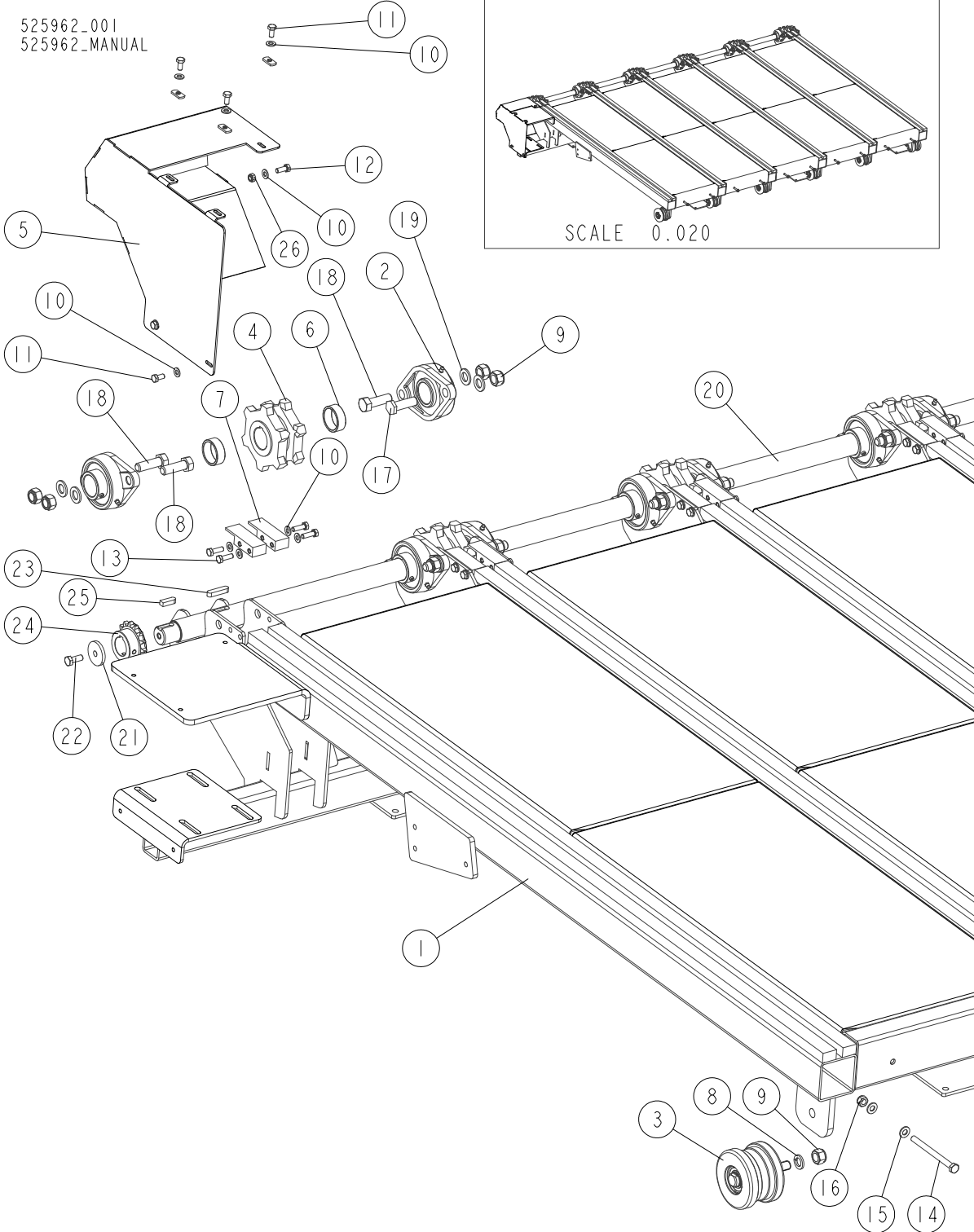

REF.	DESCRIPTION (◆ Indicates Parts Available In Assemblies Only)	PART #	QTY
-	MODULE, CHAIN CONVEYOR FRONT	525962	1
1	FRAME WELDMENT, FRONT MODULE	525960-1	1
2	BEARING, UCFL208 (KG INTERN. FZCO) W/HOUSING	099423	12
3	WHEEL	098492	6
4	SPROCKET, 16B 20Z CHAIN	097657	6

7 CC4-WIDE-SLP2-001 Chain Conveyor

Front Module

REF.	DESCRIPTION (◆ Indicates Parts Available In Assemblies Only)	PART #	QTY	
5	COVER, CHAIN	097903-1	1	
6	BUSHING, N40XN48X17 SPACER	099958-1	12	
7	BAR, FILLER	508973-1	12	
8	WASHER, 16.3 SPLIT LOCK ZINC	F81058-2	6	
9	NUT, M16-8 HEX NYLON ZINC LOCK	F81036-2	30	
10	WASHER, 8.4 FLAT ZINC	F81054-1	30	
11	BOLT, M8X16-8.8-B HEX HEAD FULL THREAD ZINC	F81002-20	5	
12	BOLT, M8X20 8.8 HEX HEAD FULL THREAD ZINC	F81002-4	1	
13	BOLT, M8X25-8.8-B HEX HEAD FULL THREAD ZINC	F81002-5	24	
14	BOLT, M10X125 8.8 HEX HEAD ZINC	F81003-18	10	
15	WASHER, 10.5 FLAT ZINC	F81055-1	20	
16	NUT, M10-8-B HEX NYLON ZINC LOCK	F81033-1	10	
17	BOLT, CHAIN SPROCKET	091744	6	
18	BOLT, M16X50-8.8 HEX HEAD FULL THREAD ZINC	F81006-7	18	
19	WASHER, 17 SPLIT LOCK ZINC	F81058-1	24	
20	SHAFT, DRIVE	525977	1	
21	WASHER, 10.5/45-6 ZINC-PLATED	086286-1	2	
22	BOLT, M10X25 8.8 HEX HEAD FULL THREAD ZINC	F81003-11	2	
23	KEY, A10X8X45 PARALLEL	091312	6	
24	SPROCKET, Z15/10B-1 T75117	525978	1	
25	KEY, AB 10X8X30 PARALLEL	525979	1	
26	NUT, M8-8-B HEX NYLON ZINC LOCK	F81032-2	1	

7.6 Rear Module

525965_001
525965_MANUAL

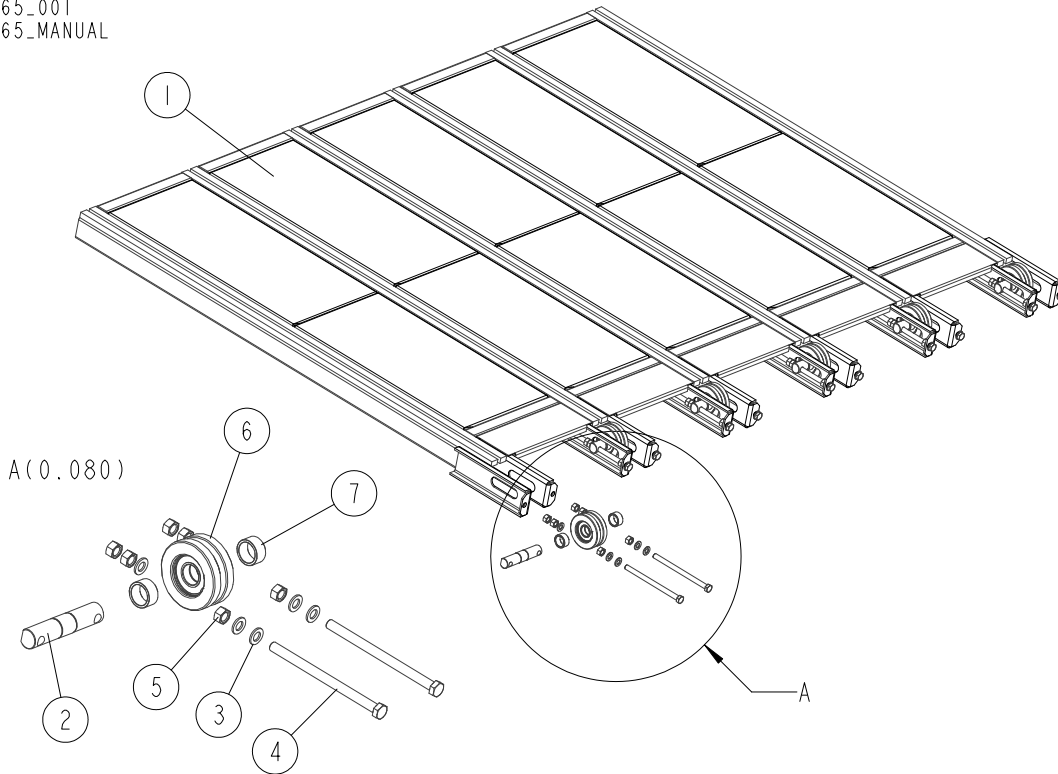

REF.	DESCRIPTION (◆ Indicates Parts Available In Assemblies Only)	PART #	QTY	
-	MODULE, CHAIN CONVEYOR REAR	525965	1	
1	FRAME WELDMENT, REAR MODULE	525966-1	1	
2	SHAFT, CHAIN TENSION WHEEL	096207-1	6	
3	WASHER, 17 SPLIT LOCK ZINC	F81058-1	36	
4	BOLT, ISO 4017-M16X240-8.8-A2E HEX HEAD FULL THREAD	F81006-29	12	
5	NUT, M16-8 HEX ZINC	F81036-1	36	
6	WHEEL, CHAIN TENSION - COMPLETE	097655	6	
7	BUSHING, 36/45-22 ZINC-PLATED	099959-1	12	

7.7 Slab Stop Assembly

525967_001
 525967_MANUAL

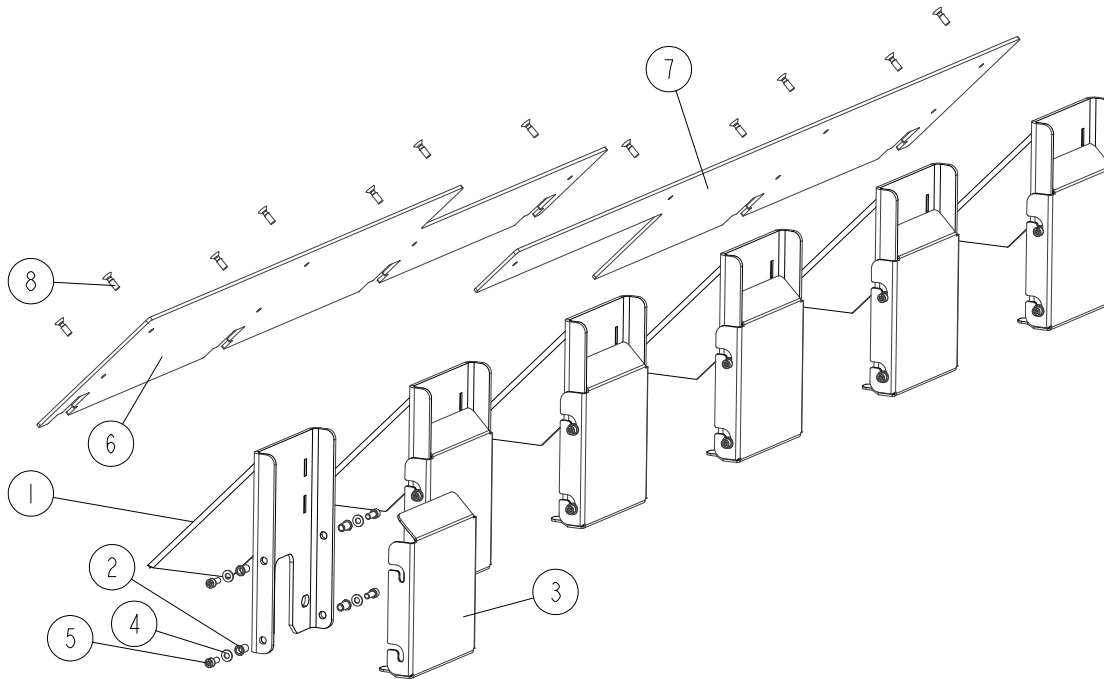

REF.	DESCRIPTION (◆ Indicates Parts Available In Assemblies Only)	PART #	QTY
-	STOP ASSEMBLY, SLAB	525967	1
1	BRACKET WELDMENT	098223-1	6
2	NUT, M8 1.0-2.5 ZINC RIVET	F81032-9	24
3	PLATE, REAR	512626-1	6
4	WASHER, 8.4 FLAT ZINC	F81054-1	21
5	SCREW, M8X20-8.8 HEX SOCKET HEAD CAP ZINC	F81002-30	24
6	PLATE, SLAB STOP	525968-1	1
7	PLATE, SLAB STOP	525969-1	1
8	SCREW, M8X25-5.8 CROSS RECESSED FLAT HEAD ZINC	F81002-51	12

7.8 Motor Kit

525985_001_A
 525985_MANUAL_PARTS

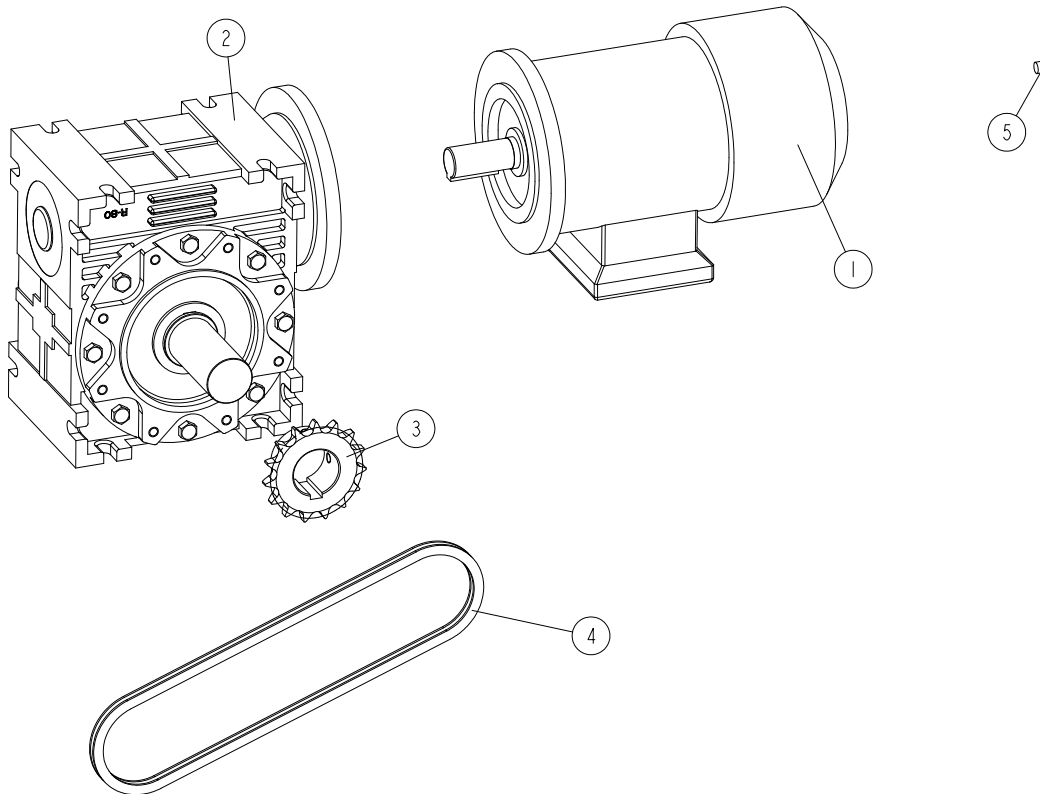

REF	DESCRIPTION (* indicates parts available in assemblies only)	PART #	QTY
-	MOTOR KIT	525985	1
-	MOTOREDUKTOR M-80/51-1.1-1400/K3/V6	588287	1
1	MOTOR SH90S-4, 1400RPM/1.1KW (PM=200/DM=24)	525983	1
2	REDUCER, R-80, I=51 (PM=200/DM=24)	525980	1
3	SPROCKET, 10B Z15 T75122	099935	1
4	CHAIN, 10B-48PZ	099781	1
5	CABLE, OLFLEX CONTROL TM 4G1,5/AWG16	R80584-76	1

7.9 Electric Box Assembly

526207_001_A
526207_MANUAL

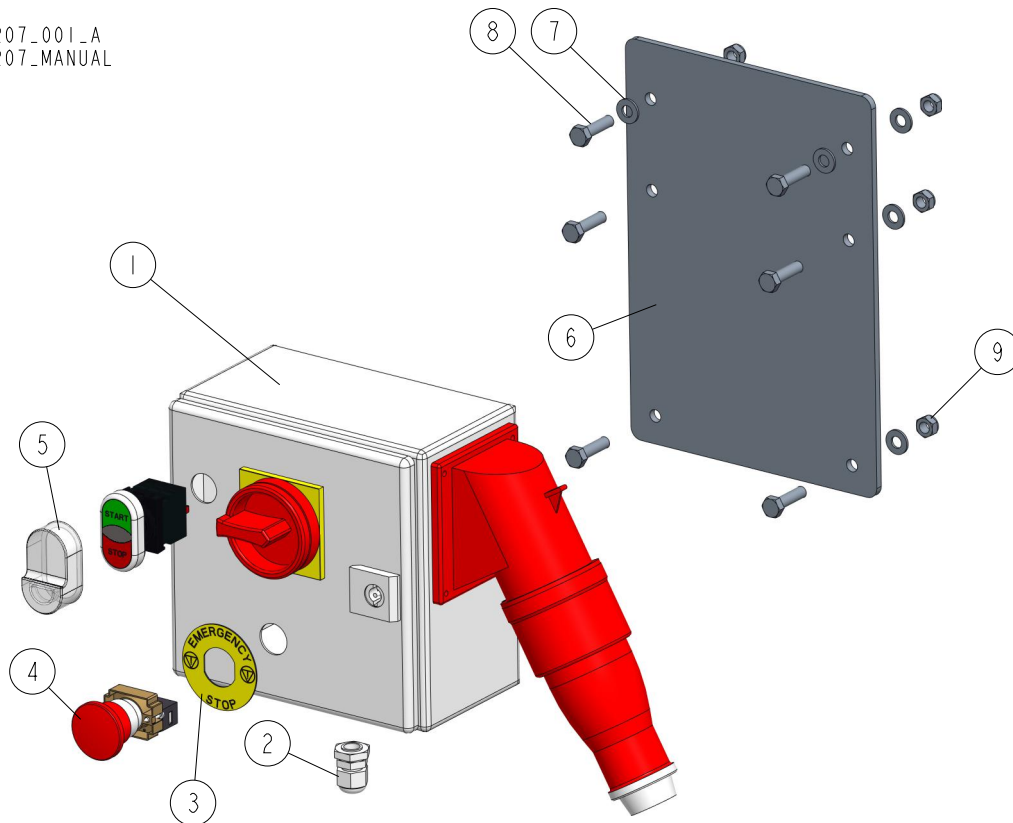

REF.	DESCRIPTION (◆ Indicates Parts Available In Assemblies Only)	PART #	QTY
-	BOX ASSEMBLY, ELECTRIC	526207	1
1	BOX, ELECTRIC	098826	1
2	GLAND, DP9/H CABLE	F81096-2	1
3	WASHER, E-STOP	086561	1
4	BUTTON, XB4 BS542 EMERGENCY STOP	086556	1
5	SWITCH, START/STOP 24V MOELLER ILLUMINATED	090452	1
6	PLATE, ELECTRIC BOX MOUNT	099550-1	1
7	WASHER, 8.4 FLAT ZINC	F81054-1	8
8	BOLT, M8X30-8.8-B HEX HEAD FULL THREAD ZINC	F81002-2	6
9	NUT, M8-8-B HEX NYLON ZINC LOCK	F81032-2	6

EC declaration of conformity according to EC Machinery Directive 2006/42/EC

We herewith declare,

Wood-Mizer Industries sp. Z O.O.
114 Nagorna street, 62-600 Kolo; Poland.

That the following described machine in our delivered version complies with the appropriate basic safety and health requirements of the EC Machinery Directive 2006/42/EC based on its design and type, as brought into circulation by us. In case of alteration of the machine, not agreed by us, this declaration is no longer valid.

Designation of the machine: **Cross Transfer Deck (SLPCTD)**

TYPE: **SLPCTD.....**

No. of manufacturer:

Applicable EC Directives: EC Machinery Directive 2006/42/EC
EC Low-Voltage Directive 73/23/EEC
EC Electromagnetic Compatibility Directive
2004/108/EC

Responsible for Technical Documentation: Roman Frontczak / R&D Director

Date/Authorized Signature: 29. 12. 2009 

Title : R&D Director