

# **Wood-Mizer®**

## **Single Vertical Saw**

### **Parts List**

---

**SVSE11S**  
**SVSE15S**

**rev. A6.07**  
**rev. A6.07**

---



**Safety is our #1 concern!** Read and understand all safety information and instructions before operating, setting up or maintaining this machine.

*Form #1009*

# Table of Contents

# Section-Page

<b>SECTION 1</b>	<b>GENERAL INFORMATION</b>	<b>1-1</b>
1.1	How To Use the Parts List.....	1-1
1.2	Sample Assembly .....	1-1
<b>SECTION 2</b>	<b>BLADE GUIDES</b>	<b>2-1</b>
2.1	Blade Guide Assembly, Idle Side.....	2-1
2.2	Blade Guide Assembly, Drive Side.....	2-3
<b>SECTION 3</b>	<b>BLADE WHEELS &amp; TENSIONER</b>	<b>3-1</b>
3.1	Blade Wheel Assembly, Drive Side .....	3-1
3.2	Blade Wheel Assembly, Idle Side.....	3-2
3.3	Blade Tensioner Assembly .....	3-3
3.4	Hydraulic Blade Pump Assembly .....	3-4
<b>SECTION 4</b>	<b>SAW HEAD</b>	<b>4-1</b>
4.1	Middle Throat Screw .....	4-1
4.2	Water Bottle Assembly(LMS).....	4-2
4.3	Saw Head Decals .....	4-4
4.4	Blade Housing Cover & Electric Box .....	4-5
4.5	Hold-Down Roller .....	4-6
4.6	Blade Drive Motor.....	4-8
4.7	Control Box & Laser Kit .....	4-9
4.8	Control Box .....	4-10
4.9	Blade Alignment Tool .....	4-12
4.10	Front Cover .....	4-13
4.11	Saw Head Tilt Adjustment Assembly .....	4-14
<b>SECTION 5</b>	<b>SVS TABLES</b>	<b>5-1</b>
5.1	Feed Track Assembly .....	5-1
5.2	Chains .....	5-3
5.3	Infeed & Outfeed Table.....	5-5
5.4	Side Table (Optional) .....	5-7

## SECTION 1 GENERAL INFORMATION

### 1.1 How To Use the Parts List

- Use the index above to locate the assembly that contains the part you need.
- Go to the appropriate section and locate the part in the illustration.
- Use the number pointing to the part to locate the correct part number and description in the table.
- Parts shown indented under another part are included with that part.
- Parts marked with a diamond (◆) are only available in the assembly listed above the part.

See the sample table below. Sample Part #A01111 includes part F02222-2 and subassembly A03333. Subassembly A03333 includes part S04444-4 and subassembly K05555. The diamond (◆) indicates that S04444-4 is not available except in subassembly A03333. Subassembly K05555 includes parts M06666 and F07777-77. The diamond (◆) indicates M06666 is not available except in subassembly K05555.

<b>1.2 Sample Assembly</b>				
REF.	DESCRIPTION (◆ Indicates Parts Available In Assemblies Only)	PART #	QTY	
	Sample Assembly, Complete (Includes All Indented Parts Below)	A01111	1	
1	Sample Part	F02222-22	1	
	Sample Subassembly (Includes All Indented Parts Below)	A03333	1	
2	Sample Part (◆ Indicates Part Is Only Available With A03333)	S04444-4	1	◆
	Sample Subassembly (Includes All Indented Parts Below)	K05555	1	
3	Sample Part (◆ Indicates Part Is Only Available With K05555)	M06666	2	◆
4	Sample Part	F07777-77	1	

#### To Order Parts:

- From Europe call our European Headquarters and Manufacturing Facility in Kolo, Poland at **+48-63-2626000**. From the continental U.S., call our toll-free Parts hotline at **1-800-525-8100**. Have your customer number, vehicle identification number, and part numbers ready when you call. From other international locations, contact the Wood-Mizer distributor in your area for parts.

#### Office Hours:

Country	Monday - Friday	Saturday	Sunday
Poland	7-15	Closed	Closed
US	8 a.m.- 5 p.m.	8 a.m.- 12 p.m.	Closed



**CAUTION!** It is strongly recommended that only original spare parts be used.

**SECTION2 BLADE GUIDES**

**2.1 Blade Guide Assembly, Idle Side**

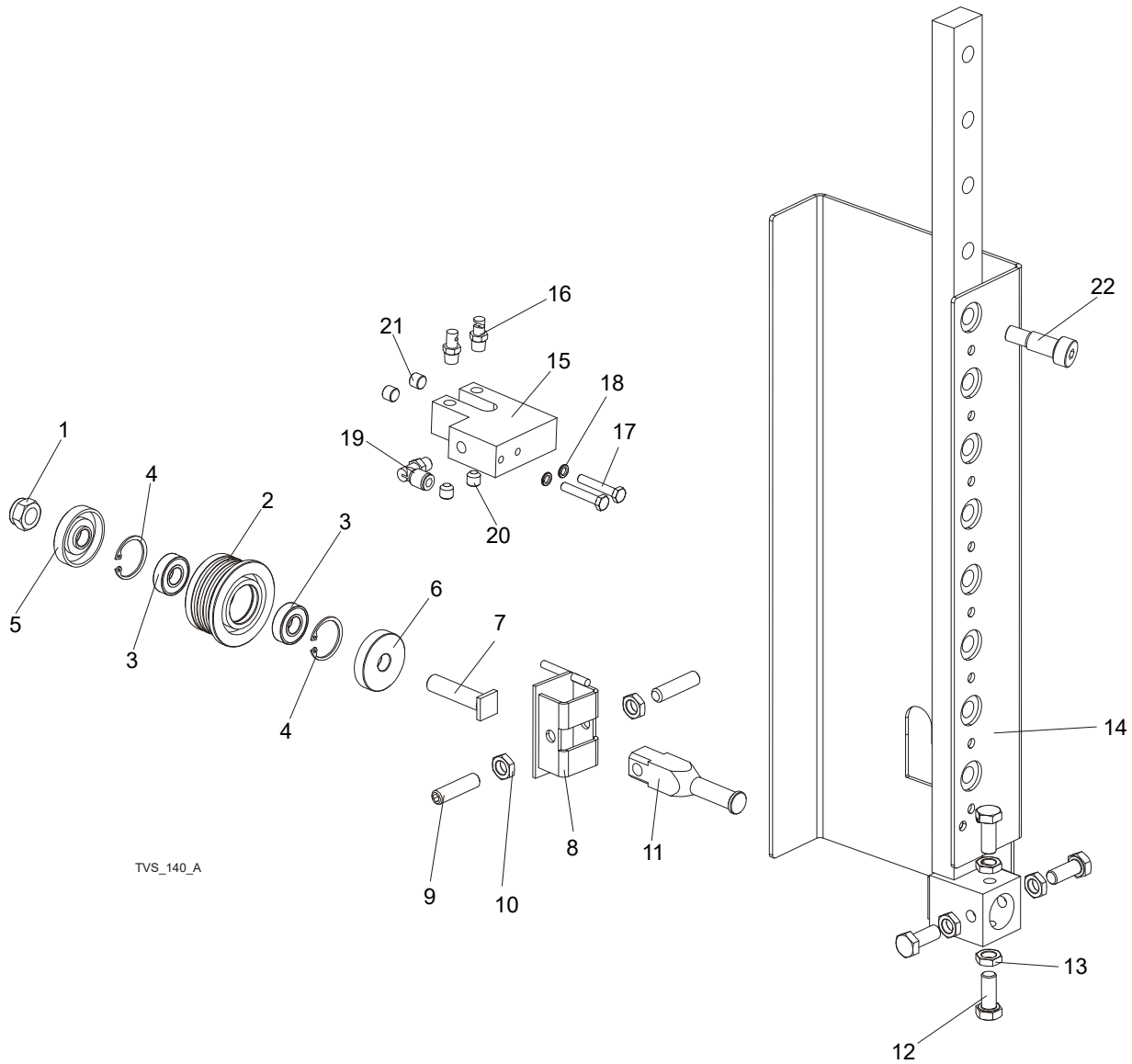

TVS\_140\_A

REF	DESCRIPTION (◆ Indicates Parts Available In Assemblies Only)	PART #	QTY.	
	<b>ROLLER, TVS BLADE GUIDE COMPLETE</b>	500562	1	
	ROLLER, TVS BLADE GUIDE	500561	1	
1	NUT, M12-8 HEX NYLON ZINC LOCK	F81034-2	1	
2	ROLLER, TVS BLADE GUIDE WIDE	500560	1	◆
3	BEARING, 6001 2RSR FAG	087893	2	
4	RING, W28 INSIDE RETAINING	F81090-9	1	
5	RING, ZINC-PLATED SPACER (FOR EXTEND.ROLL)	087891-1	1	
6	RING, ZINC-PLATED SPACER (FOR EXTEND.ROLL)	087892-1	1	
7	SHAFT, BLADE GUIDE ROLLER ZINC-PLATED	087762-1	1	
8	BRACKET WELDMENT, BLADE GUIDE PAINTED	500563-1	1	

<b>9</b>	SCREW, M10X1X40 DIN 913 A2-70 SET STAINLESS STEEL	F81015-2	2	
<b>10</b>	NUT, M10X1-04-ST-A2 ISO 8675 THIN	F81033-10	2	
<b>11</b>	SHAFT, BLADE GUIDE MOUNT ZINC-PLATED	088255-1	1	
<b>12</b>	<b>BOLT, M10x1x25 DIN 933</b>	F81003-28	4	
<b>13</b>	<b>NUT, M10x1-04-ST-A2 ISO 8675 THIN</b>	F81033-10	4	
<b>14</b>	<b>ROLLER GUIDE, TVS RIGHT-PTD</b>	508387-1	1	
	<b>ROLLER GUIDE, TVS LEFT- PTD</b>	508390-1	1	
	<b>LUBE SYSTEM, TVS</b>	098583	2	
<b>15</b>	BLOCK, NOZZLE MOUNTING ZINC-PLATED	097943-1	1	
<b>16</b>	NOZZLE, BLADE LUBE SPRAY	033479	2	
<b>17</b>	BOLT, M6x35 8.8 HEX HEAD ZINC	F81001-71	2	
<b>18</b>	WASHER, M6 SPLIT LOCK ZINC	F81053-3	2	
<b>19</b>	Fitting, 1/8MPTx1/4Tube,Elbow,Swivel	P09736	1	
<b>20</b>	Fitting, 1/8 NPT Socket Pipe Plug	P30127	2	
<b>21</b>	PLUG, M10x1 DIN 906 BN40 "BOSSARD"	F81015-3	2	
<b>22</b>	BOLT, 12/M10X20 12.9 ISO7379(BOSSARD)	F81003-68	8	

**2.2 Blade Guide Assembly, Drive Side**

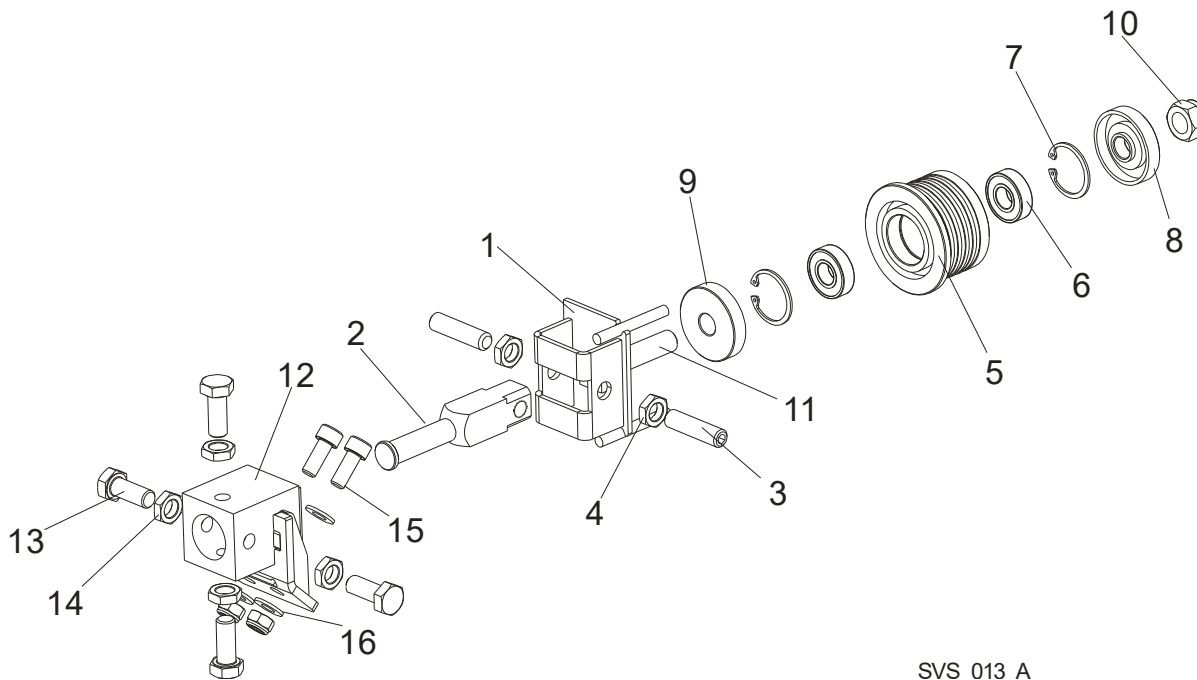

SVS 013 A

REF	DESCRIPTION (◆ Indicates Parts Available In Assemblies Only)	PART #	QTY.
	<b>ROLLER, TVS BLADE GUIDE COMPLETE</b>	500562	1
1	BRACKET WELDMENT, BLADE GUIDE PAINTED	500563-1	1
2	SHAFT, BLADE GUIDE MOUNT ZINC-PLATED	088255-1	1
3	SCREW, M10X1X40 DIN913 STAINLESS STEEL SET	F81015-2	2
4	NUT, M10X1-04-ST-A2 ISO 8675 THIN	F81033-10	2
	<b>ROLLER, TVS BLADE GUIDE</b>	500561	1
5	ROLLER, TVS BLADE GUIDE WIDE	500560	1
6	BEARING, 6001 2RSR FAG	087893	2
7	RING, W28 INSIDE RETAINING	F81090-9	1
8	RING, ZINC-PLATED SPACER (FOR EXTEND.ROLL)	087891-1	1
9	RING, ZINC-PLATED SPACER (FOR EXTEND.ROLL)	087892-1	1
10	NUT, M12-8 HEX NYLON ZINC LOCK	F81034-2	1
11	SHAFT, EXTENDED ROLLER ZINC-PLATED	087762-1	1
12	<b>BLOCK WELDMENT, BLADE GUIDE MOUNT PTD</b>	514887-1	3
13	<b>BOLT, M10X1X25 DIN 933 STAINLESS STEEL</b>	F81003-28	1
14	<b>NUT, M10x1-04-ST-A2 ISO 8675 THIN</b>	F81033-10	4
15	<b>BOLT, M8 X 30-8.8 SOCKET HEAD</b>	F81002-31	2
16	<b>WASHER, 8.2 SPLIT LOCK ZINC</b>	F81054-4	2

**SECTION 3 BLADE WHEELS & TENSIONER**

**3.1 Blade Wheel Assembly, Drive Side**

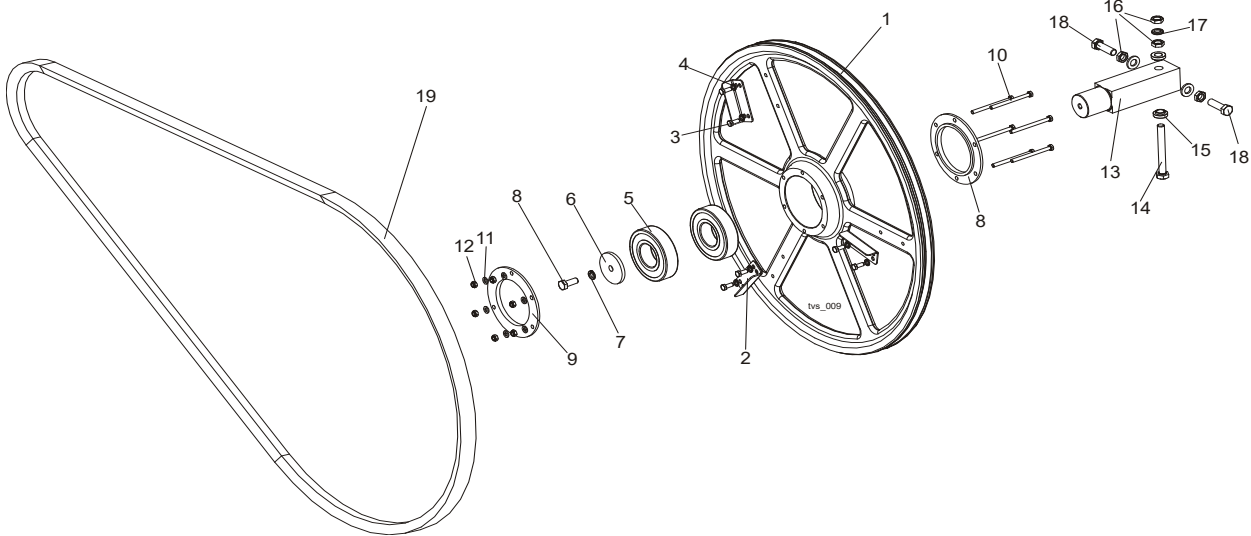

REF	DESCRIPTION (◆ Indicates Parts Available In Assemblies Only)	PART #	QTY.
	<b>DRIVE SIDE BLADE WHEEL - COMPLETE</b>	096109	1
1	Wheel, Drive Side Blade	096105-1	1
2	Wing, Sawdust Blow-Off	096363-1	3
3	Bolt, M6x16 8.8 Hex Head Full Thread Zinc	F81001-15	6
4	Washer, Z 6.1 Split Lock Zinc	F81053-3	6
5	Bearing, 6309 2RSR	096107	2
6	Washer, Idle Side Wheel Retaining Zinc-plated	088957-1	1
7	Washer, 10.2 Split Lock Zinc	F81055-2	1
8	Bolt, M10x25 8.8 Hex Head Full Thread	F81003-31	1
9	Ring, Bearing Mounting	096108-1	2
10	Bolt, M6x80 5.8 Hex Head Full Thread Zinc	F81001-61	6
11	Washer, 6.4 Flat Zinc	F81053-1	6
12	Nut, M6-8-B Hex Nylon Zinc Lock	F81031-2	6
13	<b>SHAFT, DRIVE SIDE BLADE WHEEL</b>	096110	1
14	<b>BOLT, M12X1,25X100-8,8 HEX HEAD FULL THREAD ZINC</b>	F81004-41	1
15	<b>WASHER, FLANGED ZINC-PLATED</b>	086769-1	2
16	<b>NUT, M12X1.25 8.8 THIN ZINC</b>	F81034-5	3
17	<b>WASHER, Z12.2 SPLIT LOCK ZINC</b>	F81056-2	1
18	<b>BOLT, M12x1.25x40-8.8 HEX HEAD ZINC</b>	F81004-42	2
19	<b>V-BELT, 5VX1080</b>	033391	1

# 3 BLADE WHEELS & TENSIONER

## Blade Wheel Assembly, Idle Side

### 3.2 Blade Wheel Assembly, Idle Side

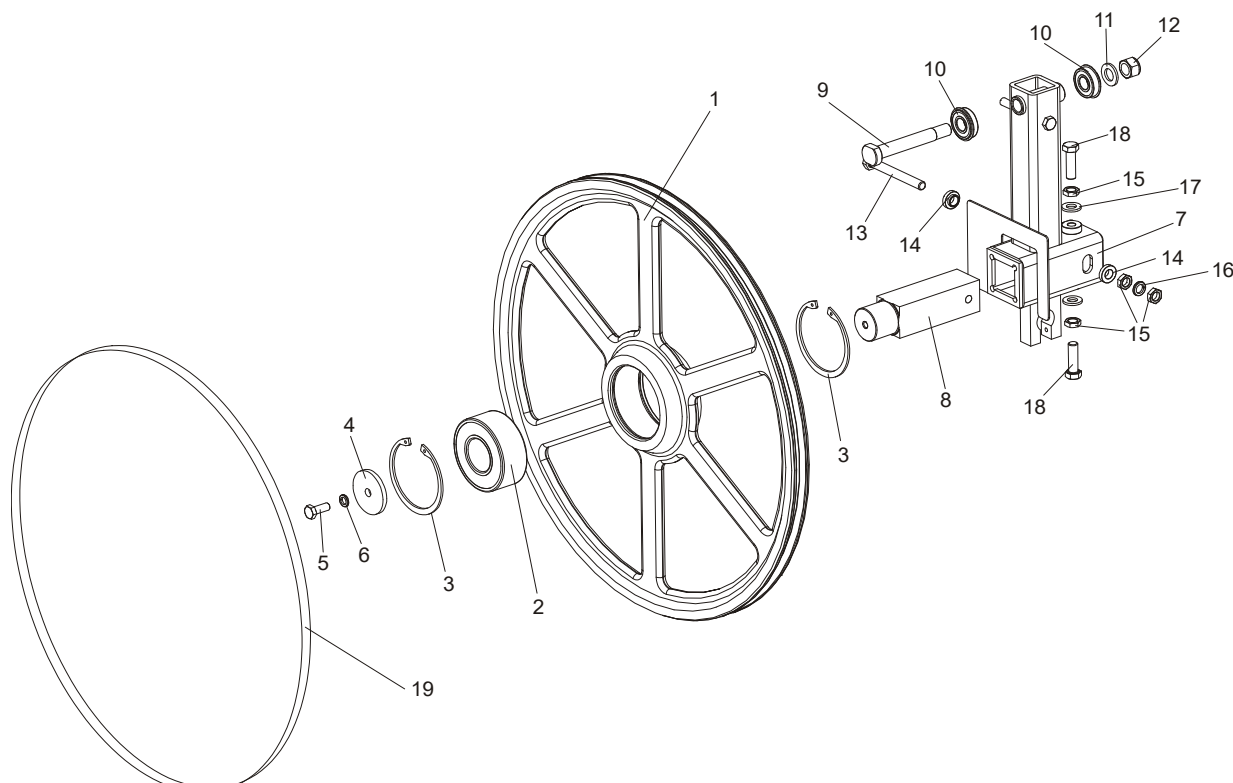

REF	DESCRIPTION (◆ Indicates Parts Available In Assemblies Only)	PART #	QTY.
	<b>IDLE SIDE BLADE WHEEL - COMPLETE</b>	088764	1
1	Wheel, Idle Side Blade Ptd	090810-1	1
2	Bearing, N/T 3309B.2RSR.TVH FAG	086428	1
3	Ring, W100 Inside Retaining	F81090-10	2
4	<b>WASHER, IDLE SIDE WHEEL RETAINING ZINC-PLATED</b>	088957-1	1
5	<b>BOLT, M10X25 8.8 HEX HEAD FULL THREAD</b>	F81003-31	1
6	<b>WASHER, 10.2 SPLIT LOCK ZINC</b>	F81055-2	1
7	<b>ARM WELDMENT, RESAW&amp;TVS IDLE SIDE WHEEL</b>	098606-1	1
8	<b>SHAFT, IDLE SIDE BLADE WHEEL</b>	088474	1
9	<b>BOLT, ARM BEARING MOUNT</b>	086404	1
10	<b>BEARING, 6203- DDUNR NSK W/SNAP RING</b>	086395	2
11	<b>WASHER, 17 FLAT ZINC</b>	F81058-1	1
12	<b>NUT, M16-8 HEX NYLON ZINC LOCK</b>	F81036-2	1
13	<b>BOLT, M12x1.25x100-8.8 HEX HEAD FULL THREAD ZINC</b>	F81004-41	1
14	<b>WASHER, FLANGED ZINC-PLATED</b>	086769-1	2
15	<b>NUT, M12X1.25 8.8 THIN ZINC</b>	F81034-5	4
16	<b>WASHER, Z12.2 SPLIT LOCK ZINC</b>	F81056-2	1
17	<b>WASHER, 13 FLAT ZINC</b>	F81056-1	2
18	<b>BOLT, M12x1.25x40-8.8 HEX HEAD ZINC</b>	F81004-42	2
19	<b>V-BELT, B72.5</b>	017922-1	1



**3.3 Blade Tensioner Assembly**

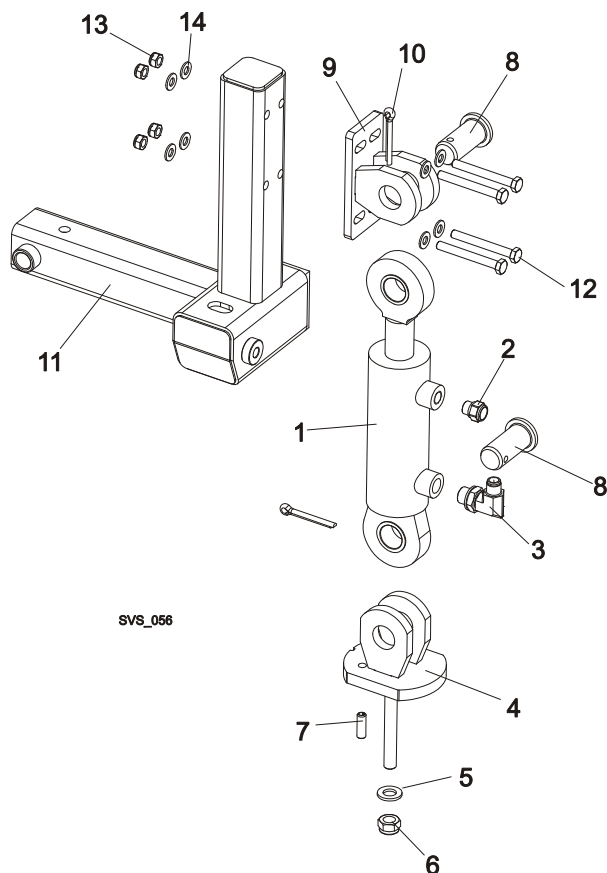

REF	DESCRIPTION (◆ Indicates Parts Available In Assemblies Only)	PART#	QTY.
	<b>HYDRAULIC BLADE TENSIONER, RIGHT SIDE</b>	504826	1
1	HYDRAULIC CYLINDER SJ2F-16-50/28/70	504812	1
2	BREATHER TYP 2901-14-17	090794	1
3	FITTING 3/8" BSP-9/16" JIC, ELBOW	096335	1
4	MOUNTING BRACKER, HYDRAULIC CYLINDER, LOWER	504822-1	1
5	WASHER, M12 , FLAT, ZINC	F81056-1	1
6	NUT,M12-8 ,HEX,NYLON,ZINC,LOCK	F81034-2	1
7	PIN, 8X26 FE/ZN5, ROLL	F81046-4	1
8	PIN, ZINK PLATED	504824-1	4
9	MOUNTING BRACKER, HYDRAULIC CYLINDER, UPPER	504819-1	2
10	PIN S-ZN 6,3X45, COTTER	F81045-2	4
11	ARM WELDMENT, TVS IDLE RIGHT SIDE BLADE WHEEL	504817-1	1
12	BOLT M8X70 8.8 FE/ZN5	F81002-71	8
13	NUT,M8-8-B,HEX,NYLON LOCK ZINC	F81032-2	8
14	WASHER, 8.4 FLAT,ZINC	F81054-1	16

# 3 BLADE WHEELS & TENSIONER

## Hydraulic Blade Pump Assembly

### 3.4 Hydraulic Blade Pump Assembly

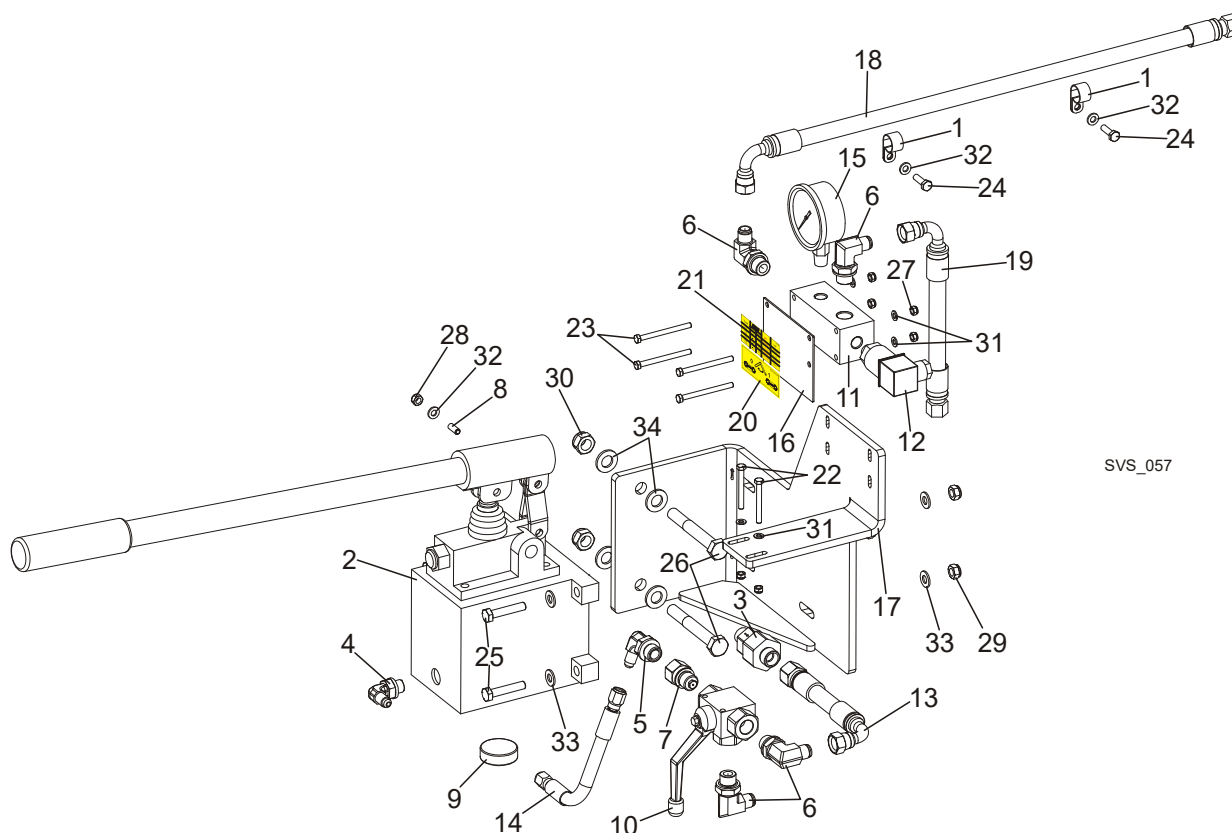

SVS\_057

REF	DESCRIPTION (◆ Indicates Parts Available In Assemblies Only)	PART#	QTY.
	<b>SUPPLY ASSEMBLY, SVS HYDRAULIC BLADE TENSIONER</b>	505306	1
1	CLAMP, 5/8 EMT COATED	010748	2
2	PUMP, PMS12/TNK1 MANUAL W/TANK 11	092789	1
3	VALVE, RHV12LREDA3C CHECK	094559	1
4	FITTING, CA-204410-3 ELBOW	094562	1
5	FITTING, CA-204411-3 ELBOW	094563	1
6	FITTING, 3/8" BSP-9/16" JIC ELBOW	096335	4
7	FITTING, G 3/8 SPECIAL	096849	1
8	STUD, GN615.3-M6-K BALL	096874	1
9	MAGNET, MW.38x12/N38 NEODYMIUM	500022	1
10	VALVE, GE5L G3/8" RELEASE	504803	1
11	BLOCK, MOUNT ZINC	504829-1	1
12	SWITCH, F4Z1/M3-20 BAR PRESSURE	504830	1
13	HOSE, 3/8" 9/16 ;M18X1,5 HYDRAULIC	504831	1
14	HOSE, 1/4"(0,19M) HYDRAULIC	505174	1
15	GAUGE, 3000psi HYDRAULIC	505176	1
16	PLATE, ZINC	505310-1	1
17	PLATE, MOUNT	505337-1	1
18	HOSE, 3/8" (0,80 M) HYDRAULIC	505338	1
19	HOSE, 3/8" DKJ 9/16 HYDRAULIC	505344	1

# BLADE WHEELS & TENSIONER

## *Hydraulic Blade Pump Assembly*

3

20	DECAL, SVS HYDRAULIC RELEASE VALVE POSITION	505347	1	
21	DECAL, PRESSURE ADJUSTMENT TABLE	505348	1	
22	BOLT, M5X45 DIN933 A2-70 STAINLESS STEEL	F81000-22	2	
23	BOLT, M5X60 DIN933 A2-70 STAINLESS STEEL	F81000-36	4	
24	BOLT, M6X20MM, HH, FULL THREAD, ZINC	F81001-2	2	
25	BOLT, 8MM X 1.25 X 40MM HH ZINC	F81002-15	4	
26	BOLT, M12X90-8.8 HEX HEAD ZINC	F81004-2	2	
27	NUT, M5-8-Fe/Zn5 DIN985	F81030-2	6	
28	NUT, M6-8-B HEX NYLON ZINC LOCK	F81031-2	1	
29	NUT, M8-8-B HEX NYLON ZINC LOCK	F81032-2	4	
30	NUT, M12-8 HEX NYLON ZINC LOCK	F81034-2	2	
31	WASHER, 5.3 FLAT ZINC	F81052-1	6	
32	WASHER, 6.4 FLAT ZINC	F81053-1	3	
33	WASHER, 8.4 FLAT ZINC	F81054-1	8	
34	WASHER, 13 FLAT ZINC	F81056-1	4	

**SECTION 4 SAW HEAD**

**4.1 Middle Throat Screw**

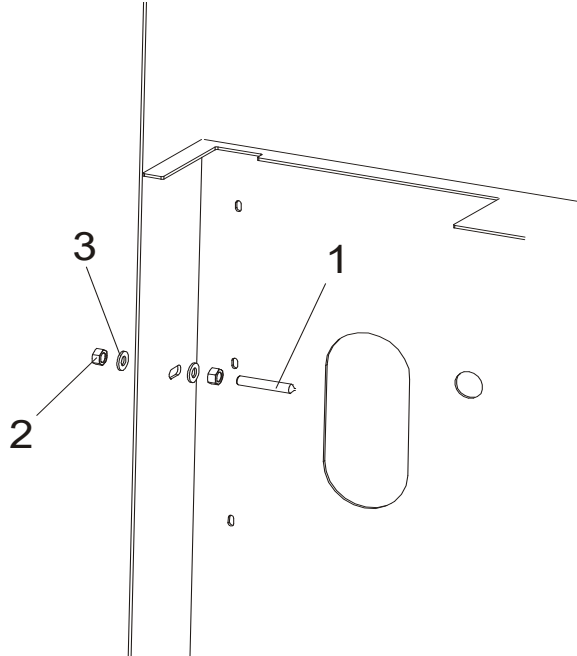

REF	DESCRIPTION (◆ Indicates Parts Available In Assemblies Only)	PART #	QTY.	
1	SCREW, M10X60-45H HEX SOCKET SET CONE POINT ZINC	F81003-87	1	
2	NUT, M10-8-B HEX ZINC	F81033-3	2	
3	WASHER, 10.5 FLAT ZINC	F81055-1	2	

## 4.2 Water Bottle Assembly(LMS)

091036\_003  
091036\_MANUAL

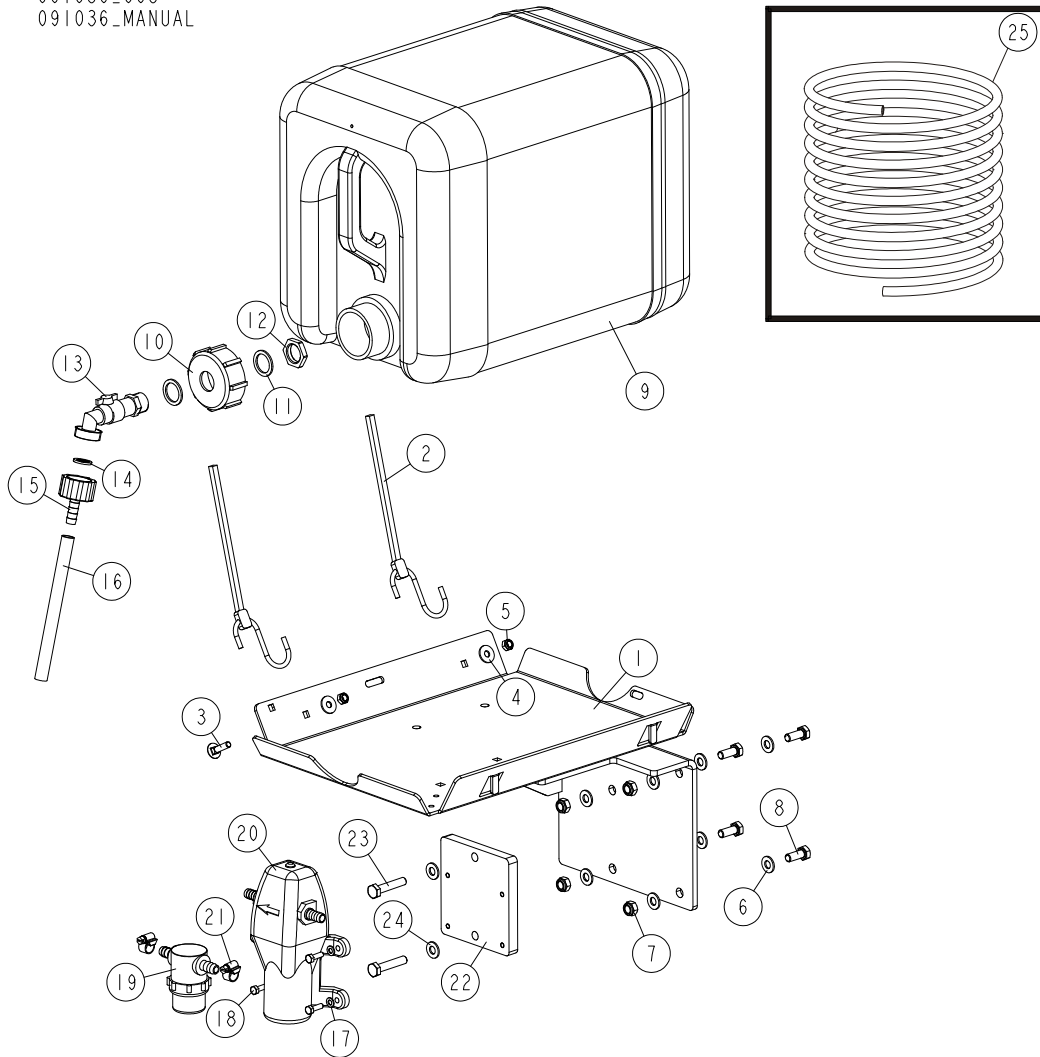

REF	DESCRIPTION (u indicates parts available in assemblies only)	PART #	QTY
-	BOTTLE KIT, LT20 WATER LUBE	091036	1
1	TRAY WELDMENT, LT20 WATER LUBE	091033-1	1
2	STRAP, 20" RUBBER W/HOOK	P11668	2
3	BOLT, M6X25-8.8 ZINC	F81001-20	2
4	WASHER, 6.5 ZINC SPECIAL FLAT	F81053-11	2
5	NUT M6 ZC 8 NYLOCK DIN 982 ISO 7040	F81031-2	2
6	WASHER, 8.4 FLAT ZINC	F81054-1	8
7	NUT, M8-8-B HEX NYLON ZINC LOCK	F81032-2	4
8	BOLT, M8X20MM, HEX HEAD,GR 5.8 ZINC,	F81002-4	4
-	TANK, OIL	550787	1
9	BOTTLE, WATER	513866	1
10	NUT, BOTTLE	550785	1
11	SEAL, 27X20X1.5 ESSENTRA 467673 RUBBER	550780	2
12	NUT, 1/2 ESSENTRA 467615 GLAND	550779	1
13	FITTING, WATER LUBE SHUTOFF VALVE	550776	1

## 4

**SAW HEAD***Water Bottle Assembly(LMS)*

REF	DESCRIPTION (u indicates parts available in assemblies only)	PART #	QTY	
14	FILTER, WATER LUBE	550778	1	
15	FITTING, G3/4" X 10MM HOSE BARB	550777	1	
16	TUBING, WATER LUBE 3/8" I.D.	R01885	1	
17	WASHER, M5, FLAT ZINC	F81052-1	4	
18	BOLT, M5X16-8.8 HEX HEAD FULL THREAD ZIN	F81000-51	4	
19	FILTER, 3/8 BARB LUBE	033447	1	
	KIT, 80 MESH FILTER SCREEN	033441	1	
20	PUMP ASSEMBLY, PRESSURE LUBE	510763	1	
21	CLAMP, 8-12MM DIA. WORM	F81080-1	2	
22	BRACKET, LMS PUMP ZINC-PLATED	098762-1	1	
23	BOLT, M8X40-8.8 HEX HEAD FULL THREAD ZIN	F81002-15	2	
24	WASHER, 8.4 FLAT ZINC	F81054-1	2	
25	HOSE, 1/4 OD 102.0 LG	033456	1	

### 4.3 Saw Head Decals

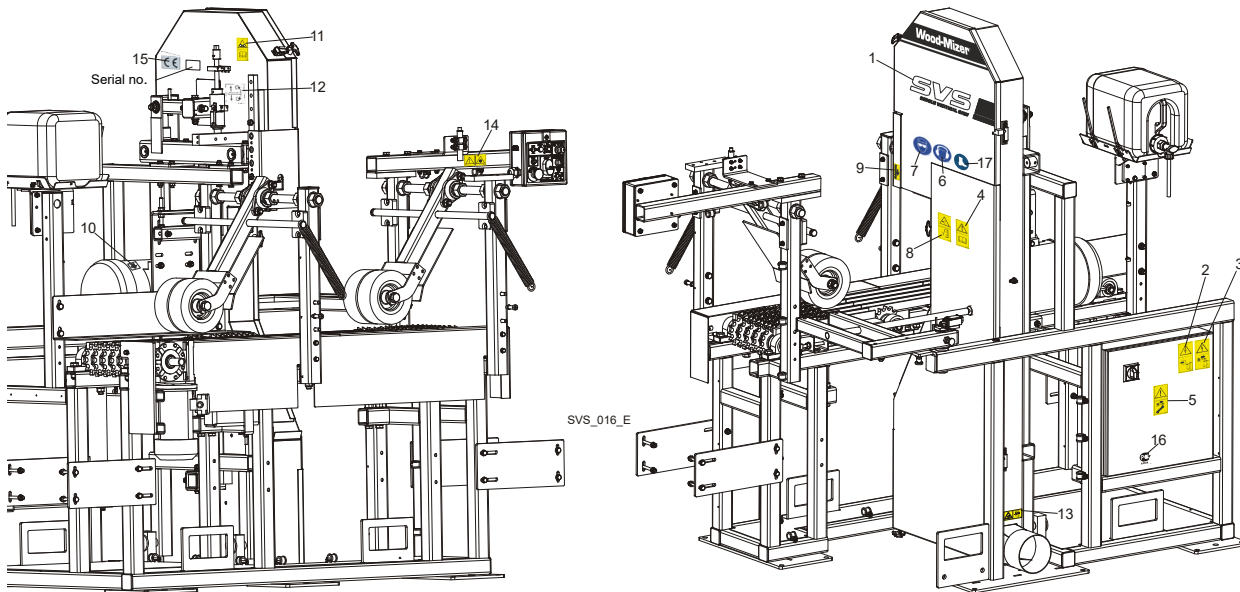

REF	DESCRIPTION (◆ Indicates Parts Available In Assemblies Only)	PART #	QTY.
	<b>SVS PICTOGRAPHIC DECAL KIT</b>	100123	1
1	DECAL KIT, SVS MACHINE NAME	099584	1
2	DECAL, HIGH VOLTAGE INSIDE THE ELECTRIC BOX	096316	1
3	DECAL, REMOVE THE PLUG BEFORE OPENING THE BOX	096319	1
4	DECAL, READ THE OPERATOR'S MANUAL	096317	1
5	DECAL, DISCONNECT POWER SUPPLY BEFORE SERVICING	098177	1
6	DECAL, EAR WARNING	S12005G	1
7	DECAL, EYE WARNING	S12004G	1
8	DECAL, SAWMILL COVERS CAUTION	099220	1
9	DECAL, BLADE MOVEMENT DIRECTION	096321	1
10	DECAL, MOTOR ROTATION DIRECTION	S20097	1
11	DECAL, BLADE TENSION - INSTRUCTIONS	099223	1
12	DECAL, BLADE ALIGNMENT	P11789	1
13	DECAL, SAWDUST CHUTE WARNING	099222	1
14	DECAL, CAUTION - LASER BEAM	099504	1
	DECALS FOR TABLES, <a href="#">See Section 5.1</a>		
15	<b>DECAL, CE CERTIFIED SAWMILL (SMALL)</b>	P85070	1
16	<b>DECAL, RUSSIAN SAFETY CERTIFICATION</b>	099401	1
17	<b>DECAL, USE SAFETY BOOTS (PICTOGRAM)</b>	501465	1

## 4.4 Blade Housing Cover &amp; Electric Box

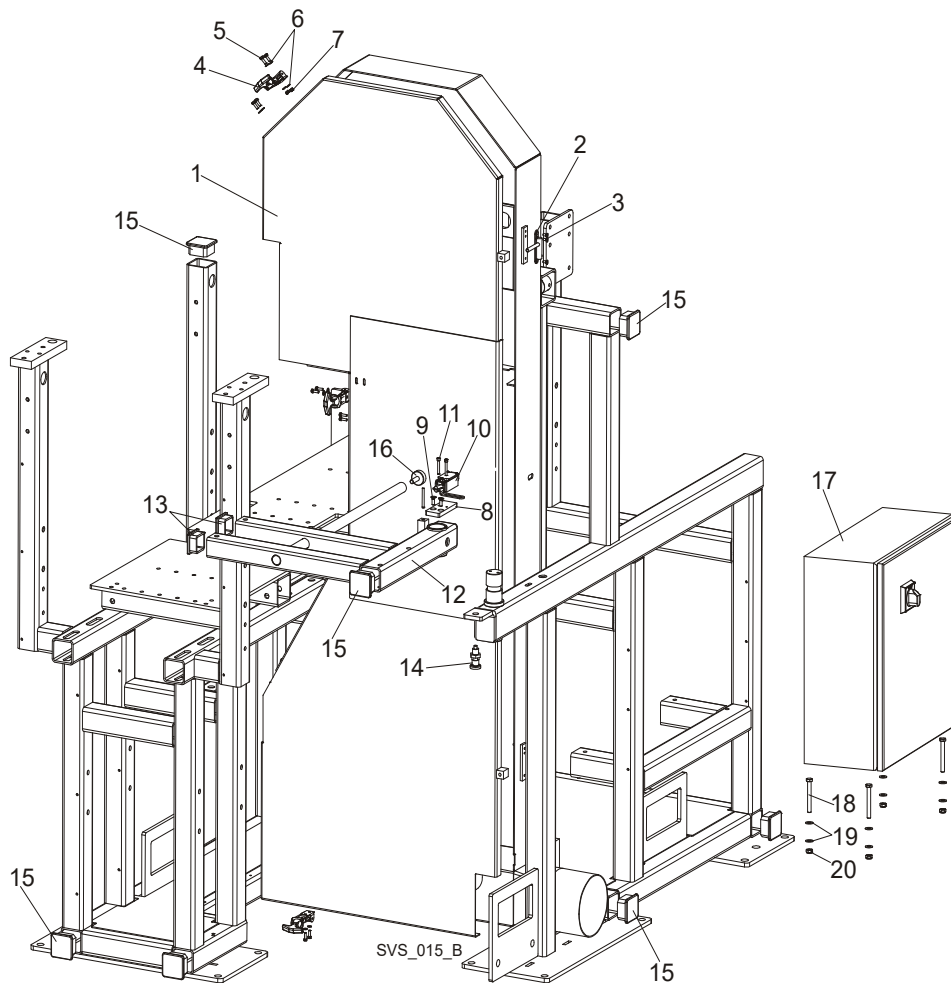

REF	DESCRIPTION (◆ Indicates Parts Available In Assemblies Only)	PART #	QTY.
1	COVER WELDMENT, BLADE HOUSING PTD (RIGHT)	096117-1	1
2	HINGE, COVER	096146	2
3	SCREW, M5x12- 5.8-B SLOTTED COUNTERSUNK ZINC	F81000-15	4
4	LATCH, FLEXIBLE DRAW	014829	3
5	BOLT, M5x16-5.8 HEX HEAD FULL THREAD ZINC	F81000-51	6
6	WASHER, 5.3 FLAT ZINC	F81052-1	12
7	NUT, M5-8 DIN 985 ZINC-PLATED	F81030-2	6
8	BAR, SAFETY SWITCH ZINC-PLATED MOUNTING	098760-1	1
9	SCREW, M6x20-4.8-B SLOTTED COUNTERSUNK ZINC	F81001-31	2
10	SWITCH, XCSPL562 SAFETY	534491	1
11	SCREW, M5x35 8.8 HEX SOCKET HEAD CAP ZINC	F81000-73	2
12	ARM WELDMENT, CONTROL BOX PTD MOUNTING (RIGHT)	096370-1	1
13	CAP, 50x50 (3-5 MM THICK) SHR TUBE END	095371	2
14	PIN, DETENT	090197	1
15	CAP, X MOSS -199211 SQUARE TUBE END	098757	8
16	FOOT, M10 BASE ADJUST	092839	1
17	BOX, SVS ELECTRIC	098071	1



18	BOLT, M8X75 8.8 HEX HEAD ZINC	F81002-91	4	
19	WASHER, 8.4 FLAT ZINC	F81054-1	8	
20	NUT, M8-8-B HEX NYLON ZINC LOCK	F81032-2	4	

### 4.5 Hold-Down Roller

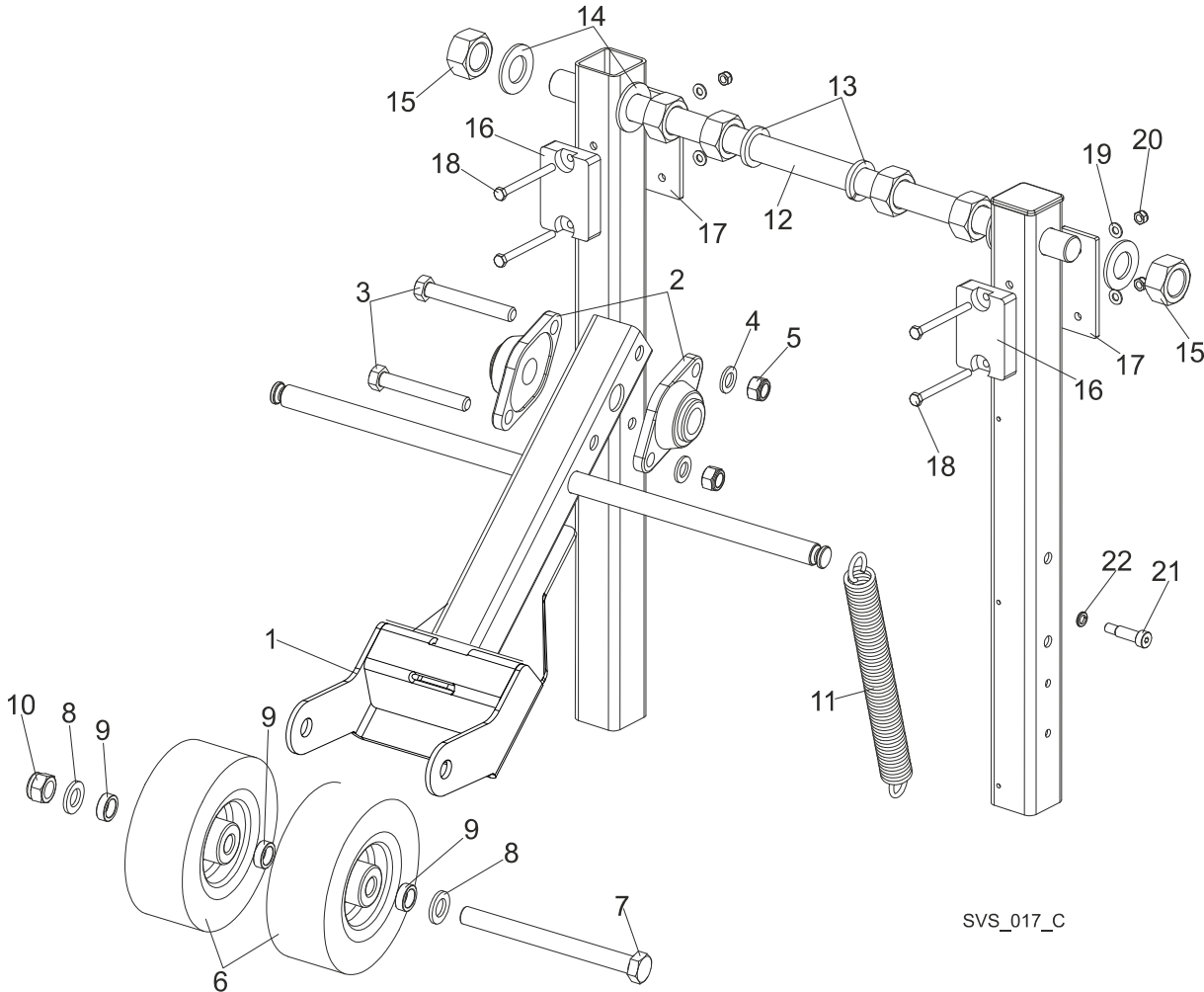

REF	DESCRIPTION (◆ Indicates Parts Available In Assemblies Only)	PART #	QTY.	
	<b>HOLD-DOWN ROLLER, COMPLETE</b>	101454	2	
1	ARM, HOLD-DOWN ROLLER	530070-1	1	
2	BEARING, UCFL 206 CX BALL	090851	2	
3	BOLT, M16X110-8.8 HEX HEAD ZINC	F81006-24	2	
4	WASHER, 17 FLAT ZINC	F81058-1	2	
5	NUT, M16-8 HEX NYLON ZINC LOCK	F81036-2	2	
6	WHEEL, 200MM DIA. 60NN (SVS)	099160	2	
7	BOLT, M20X220-8.8 HEX HEAD ZINC	F81007-4	1	
8	WASHER, 21 FLAT ZINC	F81059-2	2	
9	BUSHING, 21X30X10 ZINC-PLATED SPACER	099351-1	3	
10	NUT, M20-8-A HEX NYLON ZINC LOCK	F81037-2	1	
11	SPRING, FI 4.5X FI 35X303	091863	1	

## 4

**SAW HEAD***Hold-Down Roller*

---

12	ROD, HOLD-DOWN ARM THREADED	098145-1	2	
13	WASHER, 30.5 SPLIT LOCK ZINC	F81061-8	4	
14	WASHER, 31 FLAT ZINC	F81061-9	8	
15	NUT, M30 HEX ZINC	F81038-3	12	
16	BUMPER, GRENE 70 3201 0010. SHR RUBBER	094969	4	
17	PLATE, BUMPER SPACER	099583-1	4	
18	BOLT, M8X90-8.8 HEX HEAD FULL THREAD ZINC	F81002-16	8	
19	WASHER, 8.4 FLAT ZINC	F81054-1	8	
20	NUT, M8-8-B HEX NYLON ZINC LOCK	F81032-2	8	
21	BOLT, 12/M10X30 12.9 ISO 7379 SHOULDER	F81003-70	2	
22	WASHER, 10.2 SPLIT LOCK ZINC	F81055-2	2	

## 4.6 Blade Drive Motor

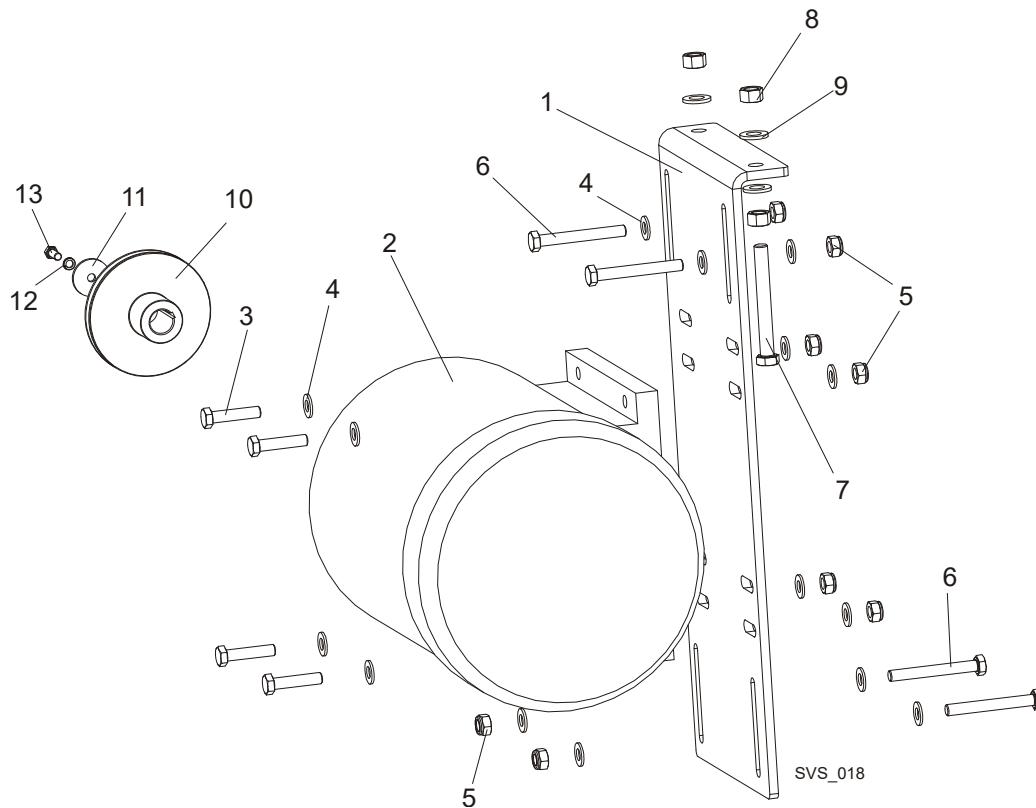

REF	DESCRIPTION (◆ Indicates Parts Available In Assemblies Only)	PART #	QTY.
1	PLATE, MOTOR MOUNTING (RIGHT)	096123-1	1
2	MOTOR, 11kW PSSG-132 S2 - HM+132	089049	1
	MOTOR, 12kW 1LA91312LA60 (USA)	P85186	1
	MOTOR ELECTRIC, 11KW(15KM) 230V NORWAY	085186-2	1
3	BOLT, M10X45-8.8 HEX HEAD FULL THREAD ZINC	F81003-3	4
4	WASHER, 10.5 FLAT ZINC	F81055-1	8
5	NUT, M10-8-B HEX NYLON ZINC LOCK	F81033-1	4
6	BOLT, M10X80-8.8 HEX HEAD ZINC	F81003-50	2
7	BOLT, M12X100 8.8 HEX HEAD FULL THREAD ZINC	F81004-45	2
8	NUT, M12-8-B HEX ZINC	F81034-1	2
9	WASHER, 13 FLAT ZINC	F81056-1	4
10	PULLEY, SPB $\Phi$ 140X1/ $\Phi$ 38 (F02325+T31079)	500571 <sup>1</sup>	1
	PULLEY, SPB $\Phi$ 170X1/ $\Phi$ 38 (F01794+T31079)	500575 <sup>2</sup>	1
	PULLEY, SPB190/1 W/2012/38 TAPER SPLIT BUSHING	099601 <sup>3</sup>	1
	PULLEY, SPB125X1/FI38 F02319+T31079 TAPER SPLIT BUSHING	501556 <sup>4</sup>	2
11	WASHER, FI 60 X 13 X 5 ZINC-PLATED SPECIAL	098613-1	1
12	WASHER, Z12.2 SPLIT LOCK ZINC	F81056-2	1
13	BOLT, M12x30-8.8 HEX HEAD FULL THREAD ZINC	F81004-22	1

<sup>1</sup> Standard Equipment. Blade Linear Velocity  $v=20.5$  m/s.

<sup>2</sup> Blade Linear Velocity  $v=25$  m/s.

<sup>3</sup> Blade Linear Velocity  $v=28$  m/s.

<sup>4</sup> Blade Linear Velocity  $v=23$  m/s.

## 4.7 Control Box &amp; Laser Kit

098840\_PULPIT\_001  
098840\_MANUAL

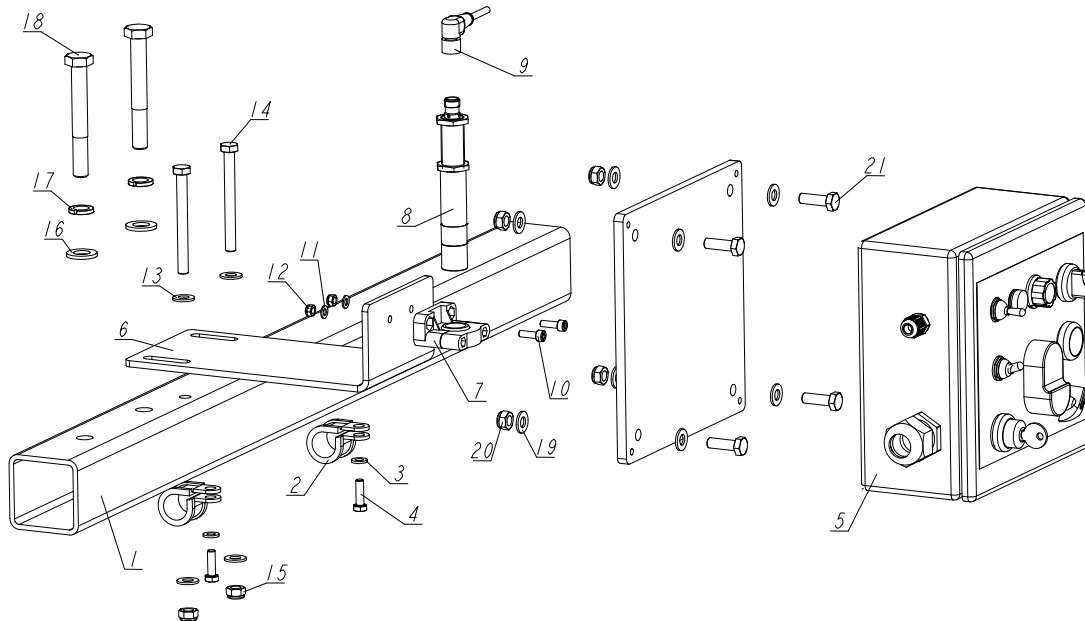

REF.	DESCRIPTION (* indicates parts available in assemblies only)	PART #	QTY
1	TUBE WELDMENT, CONTROL BOX MOUNTING	099838-1	1
2	CLIP, RSGU 1.20/20 METAL & RUBBER RETAIN	F81087-2	2
3	WASHER, 6.4 FLAT ZINC	F81053-1	2
4	BOLT, M6X20 8.8 HEX HEAD FULL THREAD ZIN	F81001-2	2
5	SVS CONTROL BOX - COMPLETE <a href="#">See Section 4.8</a>	099172	1
-	LASER KIT SVS	099873	1
6	BRACKET SVS LASER MOUNTING	099842-1	1
7	BRACKET, SMB 18SF LASER SWIVEL	503469	1
8	LASER, Z5M18B-F-532-IG90 GREEN LINE	501025	1
9	CABLE, 2M SAFETY SWITCH	094290	1
10	SCREW, M5X16-8.8 HEX SOCKET HEAD CAP ZINC	F81000-25	2
11	WASHER, 5.3 FLAT ZINC	F81052-1	2
12	NUT, M5-8 DIN985 ZINC-PLATED	F81030-2	2
13	WASHER, 8.4 FLAT ZINC	F81054-1	4
14	BOLT, M8X80-8.8 HEX HEAD ZINC	F81002-18	2
15	NUT, M8-8-B HEX NYLON ZINC LOCK	F81032-2	2
16	WASHER, 13 FLAT ZINC	F81056-1	2
17	WASHER, Z12.2 SPLIT LOCK ZINC	F81056-2	2
18	BOLT, M12X90 8.8 HEX HEAD ZINC	F81004-2	2
19	WASHER, 8.4 FLAT ZINC	F81054-1	8
20	NUT, M8-8-B HEX NYLON ZINC LOCK	F81032-2	4
21	BOLT, M8X25-8.8-B HEX HEAD FULL THREAD Z	F81002-5	4

## 4.8 Control Box

099172\_001  
099172\_MANUAL

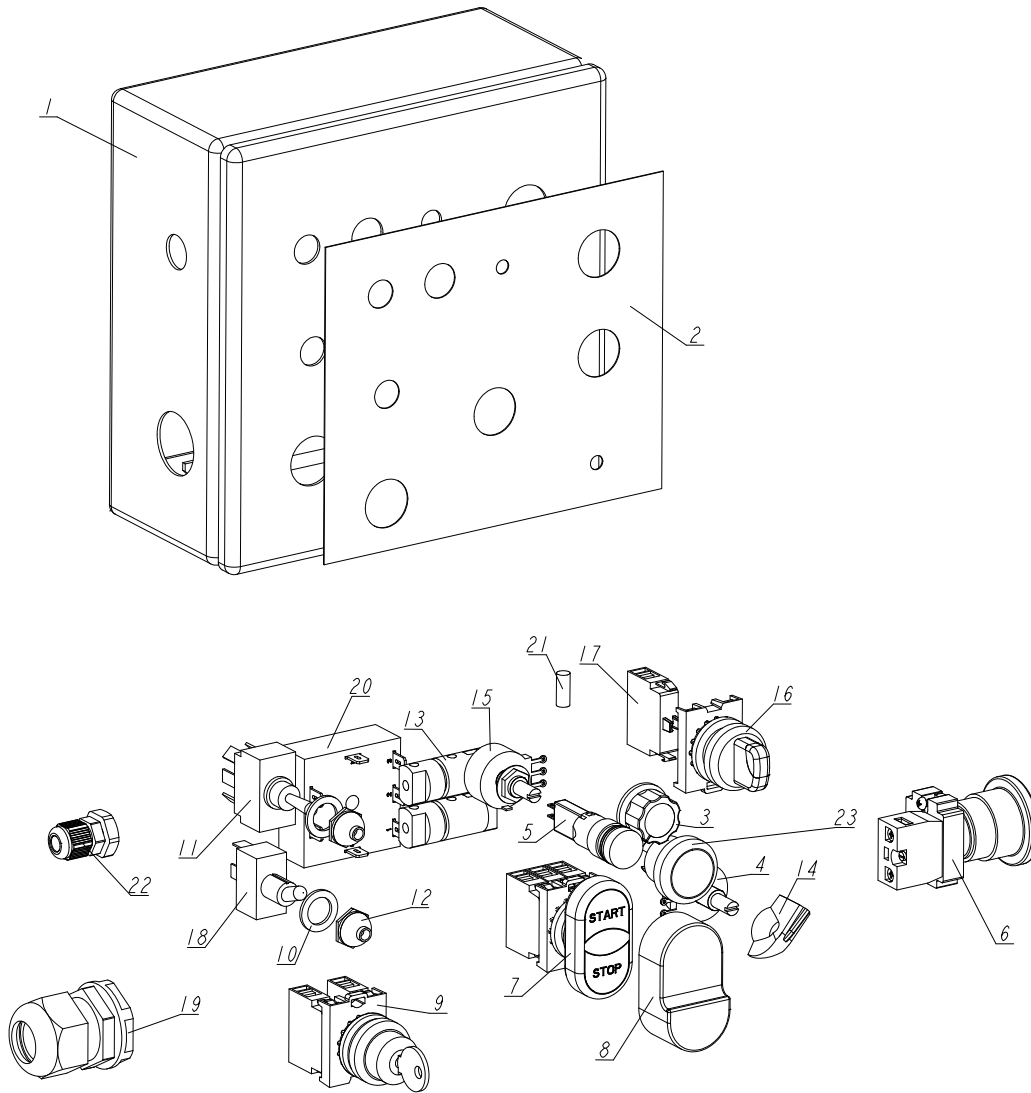

REF.	DESCRIPTION (* indicates parts available in assemblies only)	PART #	QTY
-	<b>SVS CONTROL BOX - COMPLETE</b>	099172	1
1	BOX, ABS B202010 200X200X100	588207	1
2	DECAL, SVS CONTROL BOX	099141	1
3	KNOB, 1/4"ID FLUTED ROUND PLASTIC	033478	1
4	POT, 500K 2W 10% CP PANEL MOUNT	024553	1
5	LIGHT, XB6AV3BB GREEN	087348	1
6	BUTTON, LPCB6644 EMERGENCY STOP	535445-K	1
7	START/STOP SWITCH	535451-K	1
8	MEMBRANE M22-T-DD	090462	1
9	SWITCH, LPCS330 COMPLETE	536915	1
10	WASHER, 1/2X3/4X1/16 NYLON	P05251-1	2

## 4

**SAW HEAD***Control Box*

REF.	DESCRIPTION (* indicates parts available in assemblies only)	PART #	QTY	
11	SWITCH, DPDT ON/OFF/ON 15A TOGGLE	024588	1	
12	BOOT, TOGGLE SWITCH	P02575	2	
13	FITTING, FUSE, WITH WIRE CE PROTECTION	E85238	2	
14	KNOB, SPEED CONTROL	P06257	1	
15	POTENTIOMETER, 1K	E20519	1	
16	SWITCH, 3-POSITION NON-SELF-RETURN MOELLER	545714	1	
17	CONTACT, M22 - K10	091362	1	
18	SWITCH, TOGGLE	P03027	1	
19	GLAND, DP21/H CABLE	F81096-3	1	
20	TIMER, REPEAT CYCLE 12VDC 1A .2-60SEC.	024530	1	
21	RESISTOR, 47K / 0,25W	094807	1	
22	GLAND, DP 7/H CABLE	F81096-11	1	
23	BUTTON, LPCB2102 - COMPLETE	535437-K	1	

**4.9 Blade Alignment Tool**

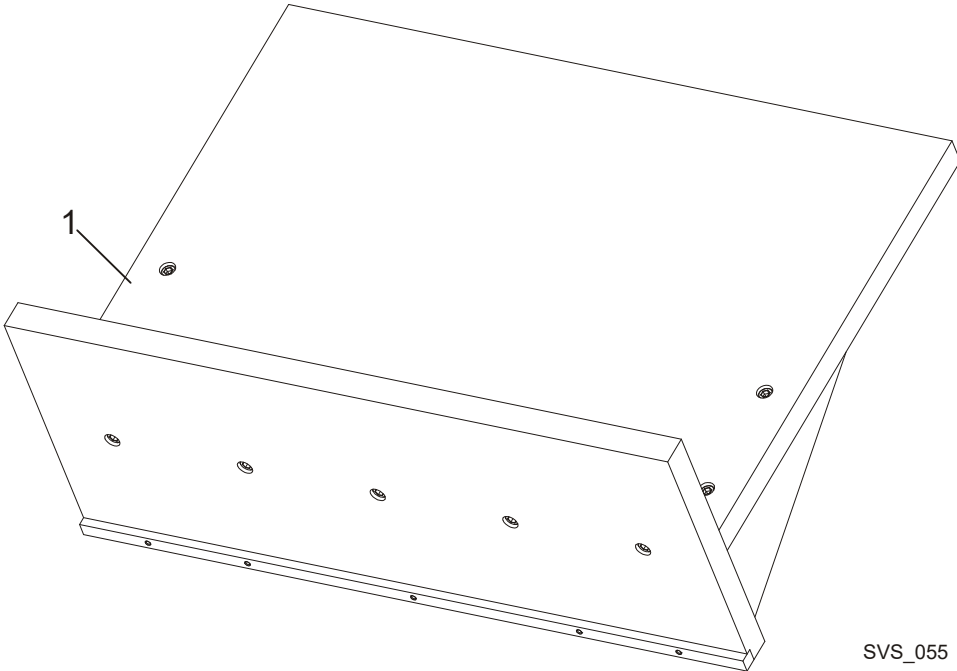

REF	DESCRIPTION (◆ Indicates Parts Available In Assemblies Only)	PART #	QTY.	
1	TOOL, SVS BLADE ALIGNMENT	100155	1	

**4.10 Front Cover**

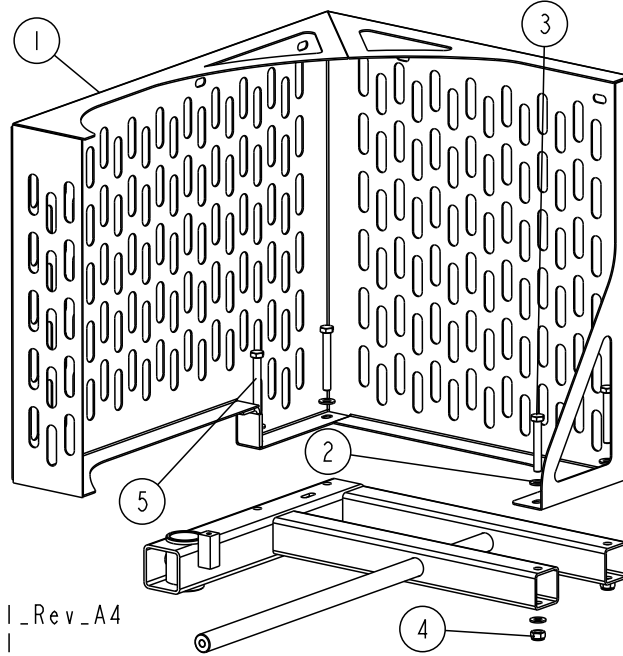

SVS\_063  
099855\_Manual\_Rev\_A4  
099855\_Rev\_EI  
098840\_Rev\_HI

REF	DESCRIPTION (* Indicates Parts Available in Assemblies Only)	PART #	QTY
1	COVER, FRONT, SVS WELDMENT	515723-1	1
2	WASHER, 10.5 FLAT ZINC	F81055-1	8
3	BOLT, M10 X 70-8.8 FE/ZN5, PN-M/82105	F81003-20	2
4	NUT, M10-8-B HEX NYLON ZINC LOCK	F81033-1	4
5	BOLT, M10 X 80 -8.8- FE/ZN5 HEX HEAD	F81003-50	2



## 4.11 Saw Head Tilt Adjustment Assembly

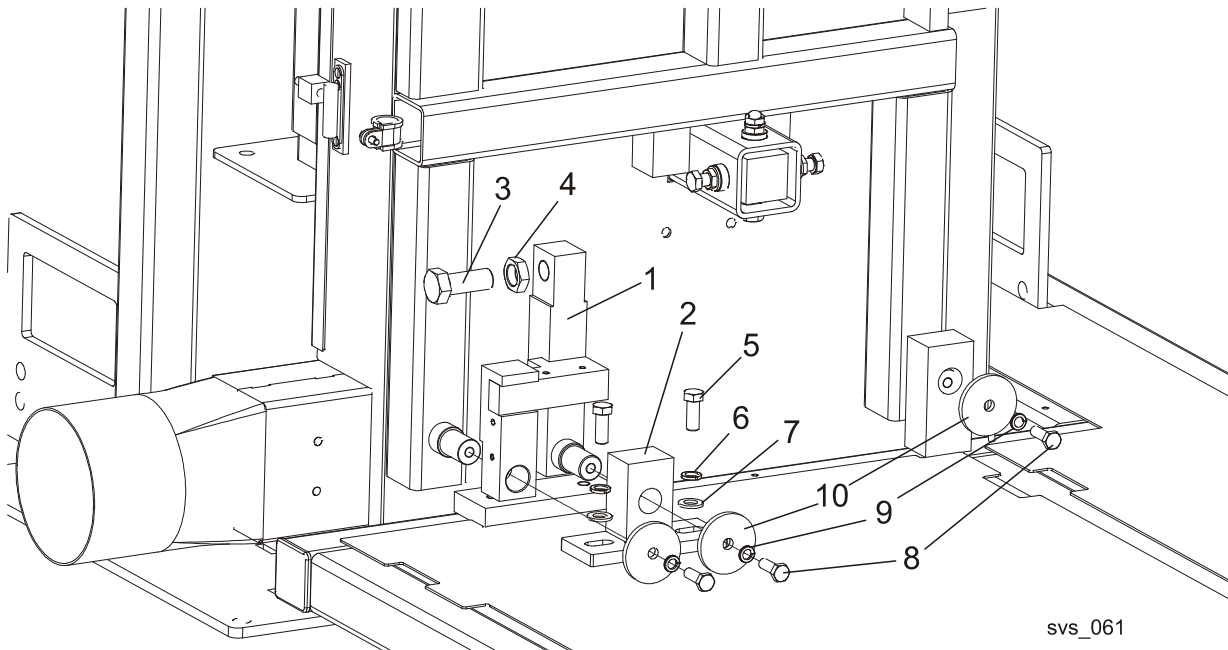

REF	DESCRIPTION (◆ Indicates Parts Available In Assemblies Only)	PART #	QTY.
1	BRACKET ROLLER ADJUSTMENT PAINTED	100177-1	1
2	BRACKET SAW HEAD	509893-1	1
3	BOLT M20X1,5X50-8.8-B-FE/ZN5 PN/M-82105	F81007-2	1
4	NUT LOW M20X1,5 FE/ZN5 PN-M/82153	F81037-7	1
5	BOLT M12X30-8.8	F81004-22	2
6	WASHER, M12 SPLIT LOCK ZINC	F81056-2	2
7	WASHER, M12 , FLAT, ZINC	F81056-1	2
8	BOLT,M10X30-5.8 HEX HEAD FULL THREA	F81003-2	3
9	WASHER,10.2 SPLIT LOCK ZINC	F81055-2	3
10	WASHER, IDLE BLADE WHEEL RETAINING	088957-1	3

## SECTION 5 SVS TABLES

### 5.1 Feed Track Assembly

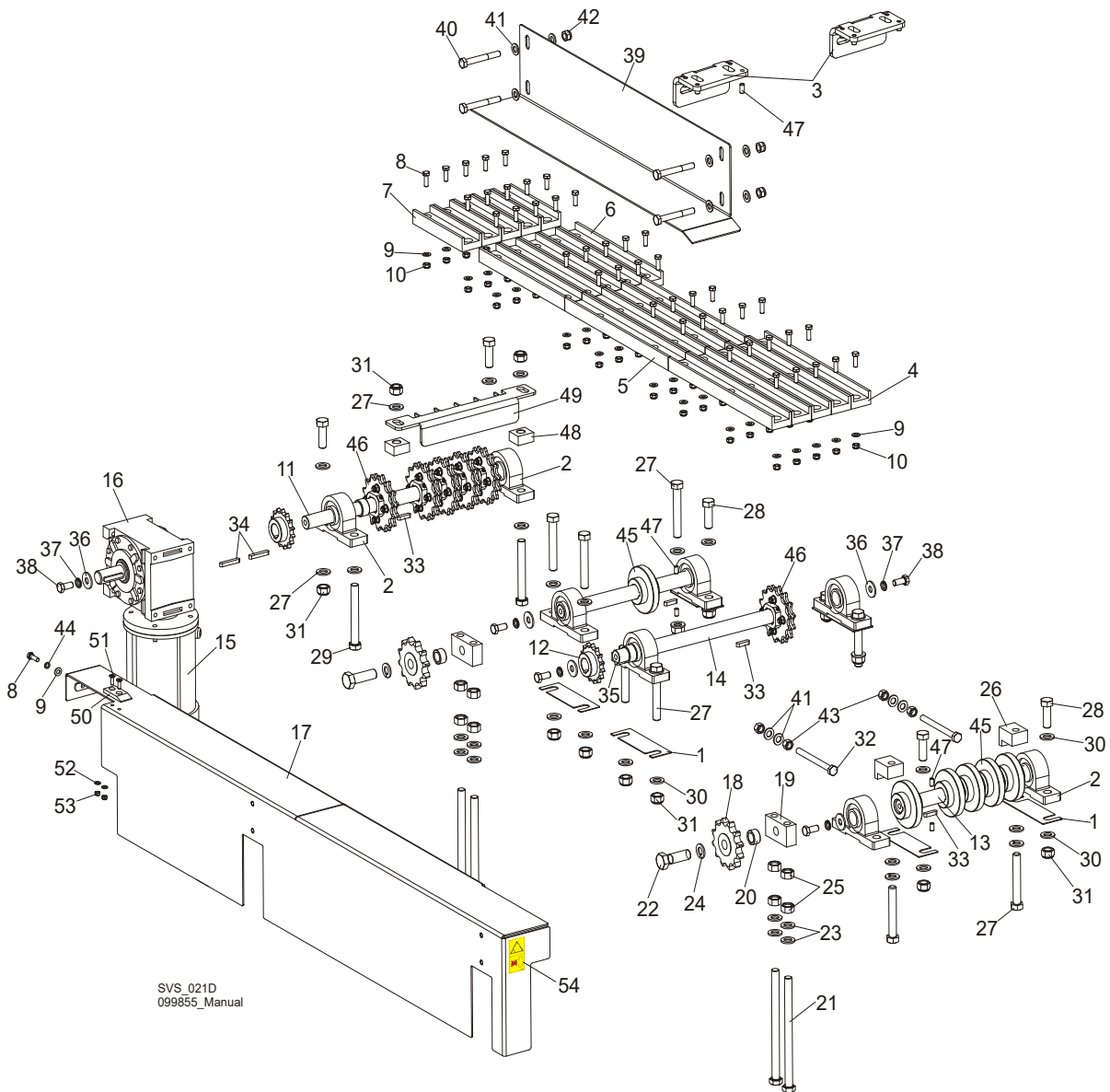

SVS\_021D  
099855\_Manual

REF	DESCRIPTION (◆ Indicates Parts Available In Assemblies Only)	PART #	QTY.
1	PLATE, UCP206 BEARING HOUSING SPACER	099846-1	6
2	BEARING, UCP 206 CX W/HOUSING	099254	8
3	PLATE, SVS SAW HEAD REGULATION	512667-1	2
4	BAR, CHAIN GUIDE (INFEED SIDE)	099385	5
5	BAR, CHAIN GUIDE (MIDDLE)	099387	4
6	BAR, CHAIN GUIDE - MIDDLE	101343	5
7	BAR, CHAIN GUIDE - SHORT	101342	5
8	BOLT, M8X25-8.8-B HEX HEAD FULL THREAD ZINC	F81002-5	39
9	WASHER, 8.4 FLAT ZINC	F81054-1	39
10	NUT, M8-8-B HEX NYLON ZINC LOCK	F81032-2	39

11	SHAFT, SVS DRIVE	099388	1	
12	SPROCKET, 10B Z15 FI28	097947	2	
13	SHAFT, SVS DRIVEN	099389	1	
14	SHAFT, SVS IDLE SIDE	099390	2	
15	MOTOR IND. SKH80X-4C1 IMB14/1-162	090104	1	
16	GEAR BOX, WORM MR-63/39-160/19-V6	557137	1	
17	GUARD, SVS DRIVE	098321-1	1	
	COMPLETE SHORT CHAIN TENSIONER	099832	2	
18	SPROCKET, KSR20-LO-16-10-12-15	099746	1	
19	BLOCK, SHORT CHAIN TENSIONER	099830-1	1	
20	BUSHING, $\phi 20.5 \times \phi 30 \times 15$ SPACER	100105-1	2	
21	BOLT, M16X240-8.8-A2 FULL THREAD	F81006-29	2	
22	BOLT, M20X60 8.8 HEX HEAD ZINC	F81007-7	1	
23	WASHER, 17 FLAT ZINC	F81058-1	6	
24	WASHER, 16.3 SPLIT LOCK ZINC	F81058-2	1	
25	NUT, M16-5.8 HEX ZINC	F81036-1	4	
26	BLOCK, LONG CHAIN TENSIONER	099829-1	2	
27	BOLT, M16X110-8.8 HEX HEAD ZINC	F81006-24	6	
28	BOLT, M16X50-8.8 HEX HEAD FULL THREAD ZINC	F81006-7	6	
29	BOLT, M16X130-8.8 HEX HEAD ZINC	F81006-35	2	
30	WASHER, 17 FLAT ZINC	F81058-1	32	
31	NUT, M16-8 HEX NYLON ZINC LOCK	F81036-2	16	
32	BOLT, M12X130-8.8 HEX HEAD FULL THREAD ZINC	F81004-55	2	
33	KEY, A8X7X32 PARALLEL	088564	7	
34	KEY, A8X7X50 PARALLEL	088563	2	
35	KEY, AB 8X7X25 PARALLEL	099848	1	
36	WASHER, 13 SPECIAL FLAT ZINC	F81056-14	8	
37	WASHER, Z12.2 SPLIT LOCK ZINC	F81056-2	10	
38	BOLT, M12X25-8.8 HEX HEAD FULL THREAD ZINC	F81004-31	8	
39	FENCE, FEED TRACK SIDE	099849-1	1	
40	BOLT, M12X90-8.8 HEX HEAD ZINC	F81004-2	4	
41	WASHER, 13 FLAT ZINC	F81056-1	12	
42	NUT, M12-8 HEX NYLON ZINC LOCK	F81034-2	4	
43	NUT, M12-8-B HEX ZINC	F81034-1	4	
44	WASHER, 8.2 SPLIT LOCK ZINC	F81054-4	1	
45	WHEEL, 16B CHAIN TENSION	101088-1	6	
46	SPROCKET, 14Z D30 COMPLETE	101446	6	
47	SCREW, M8X16-33H HEX SOCK. FLAT POINT SET	F81014-2	20	
48	DISTANCE BLOCK, SAWDUST WIPER	101449-1	2	
49	WIPER, SVS SPROCKET ZINC	101396-1	1	
50	PLATE, SLIDE ZINC	504477-1	1	
51	SCREW, M6X20-10.9 FE/ZN5 DIN-7991	F81001-17	2	
52	WASHER, M6, FLAT ZINC	F81053-1	2	
53	NUT, M6-8-B HEX,NYLON LOCK ZINC	F81031-2	2	
54	DECAL, GEAR WARNING	099540	1	

**5.2 Chains**

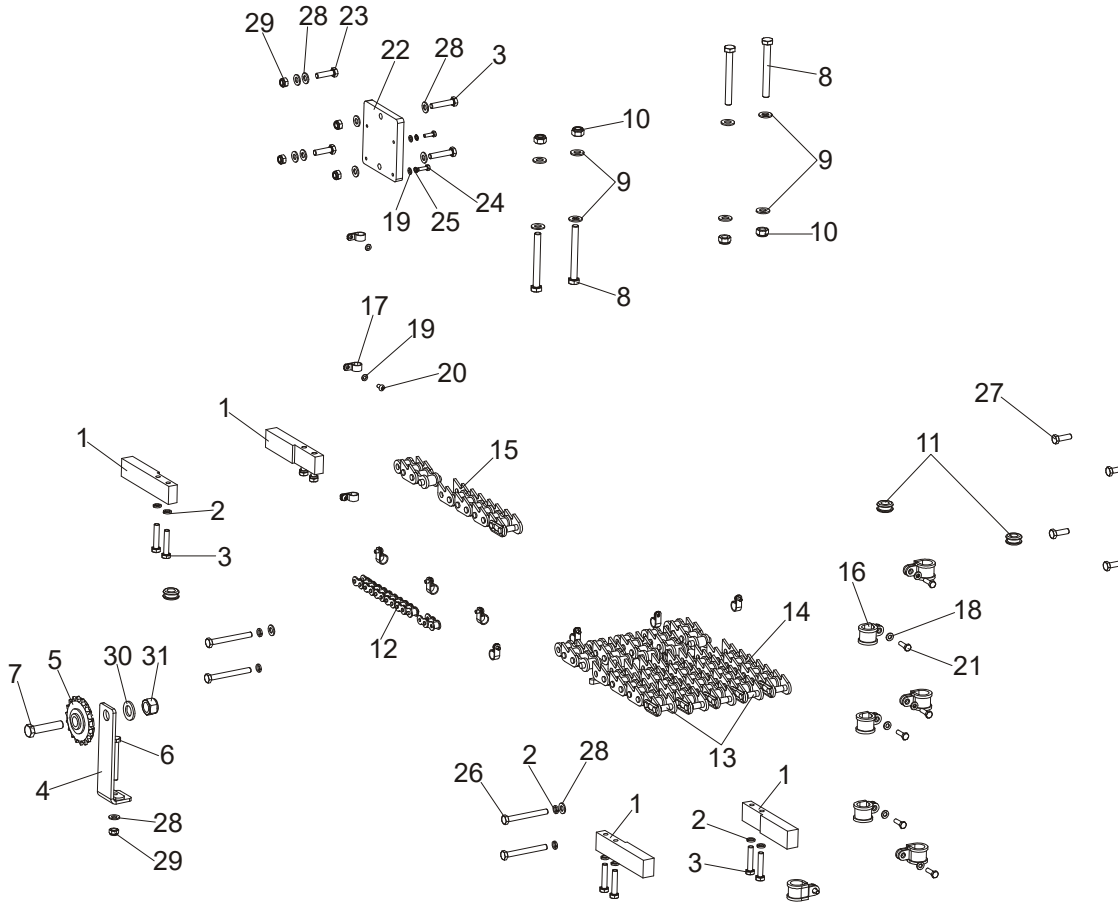

REF	DESCRIPTION (◆ Indicates Parts Available In Assemblies Only)	PART #	QTY.
1	<b>BLOCK, SVS CHAIN SPACER</b>	099591-1	4
2	<b>WASHER, 8.2 SPLIT LOCK ZINC</b>	F81054-4	13
3	<b>BOLT, M8X40-8.8 HEX HEAD FULL THREAD ZINC</b>	F81002-15	10
4	<b>BRACKET WELDMENT, POWER FEED CHAIN TENSIONER</b>	092862-1	1
5	<b>SPROCKET, Z=18 KSR16.L0.08.10.18.09</b>	088700	1
6	<b>BOLT, M8X65-5.8 HEX HEAD ZINC</b>	F81002-3	1
7	<b>BOLT, M12X55-8.8 HEX HEAD ZINC</b>	F81004-12	1
8	<b>BOLT, M10X90-8.8-B HEX HEAD ZINC</b>	F81003-66	4
9	<b>WASHER, 10.5 FLAT ZINC</b>	F81055-1	8
10	<b>NUT, M10-8-B HEX NYLON ZINC LOCK</b>	F81033-1	4
11	<b>GROMMET, 20/13 RUBBER</b>	086188	3
12	<b>CHAIN, 10B-1 142 LINKS (2255) - COMPLETE</b>	099870	1
	CHAIN, 10B-1 143 LINKS (2270.1)	099871	1
	LINK, 10B-1Pz MASTER	088671	1
13	<b>CHAIN, 1" 135 LINKS (3429) - COMPLETE, SPECIAL</b>	099866	4
	CHAIN, 1" 135 LINKS (3429) SPECIAL	099101	4
	LINK, 1" SPECIAL CHAIN MASTER	099869	4
14	<b>CHAIN, 1" 61 LINKS (1549.4) - COMPLETE, SPECIAL</b>	099867	1

	CHAIN, 1" 61 LINKS (1549.4) SPECIAL	099843	1	
	LINK, 1" SPECIAL CHAIN MASTER	099869	1	
<b>15</b>	<b>CHAIN, 1" 75 LINKS (1905) - COMPLETE, SPECIAL</b>	099868	1	
	CHAIN, 1" 75 LINKS (1905) SPECIAL	099844	1	
	LINK, 1" SPECIAL CHAIN MASTER	099869	1	
<b>16</b>	<b>CLAMP, RSGU 1.20/20 W1 WIRE</b>	F81087-2	16	
<b>17</b>	<b>CLAMP, 1/2 WIRE PLASTIC</b>	F05114-1	10	
<b>18</b>	<b>WASHER, 6.4 FLAT ZINC</b>	F81053-1	16	
<b>19</b>	<b>WASHER, 5.3 FLAT ZINC</b>	F81052-1	14	
<b>20</b>	<b>SCREW, H M5X10 8.8 CROSS RECESSED PAN HEAD ZINC</b>	F81000-13	10	
<b>21</b>	<b>BOLT, M6X20-8.8 HEX HEAD FULL THREAD ZINC</b>	F81001-2	16	
<b>22</b>	<b>BRACKET, LMS PUMP ZINC-PLATED</b>	098762-1	1	
<b>23</b>	<b>BOLT, M8X30-8.8-B HEX HEAD FULL THREAD ZINC</b>	F81002-7	2	
<b>24</b>	<b>BOLT, M5X16-5.8 HEX HEAD FULL THREAD ZINC</b>	F81000-51	4	
<b>25</b>	<b>WASHER, 5.1 SPLIT LOCK ZINC</b>	F81052-2	4	
<b>26</b>	<b>BOLT, M8X75 8.8 HEX HEAD ZINC</b>	F81002-91	4	
<b>27</b>	<b>BOLT, M8X25-8.8-B HEX HEAD FULL THREAD ZINC</b>	F81002-5	4	
<b>28</b>	<b>WASHER, 8.4 FLAT ZINC</b>	F81054-1	9	
<b>29</b>	<b>NUT, M8-8-B HEX NYLON ZINC LOCK</b>	F81032-2	2	
<b>30</b>	<b>WASHER, 17 FLAT ZINC</b>	F81058-1	1	
<b>31</b>	<b>NUT, M16-8 HEX NYLON ZINC LOCK</b>	F81036-2	1	

### 5.3 Infeed & Outfeed Table

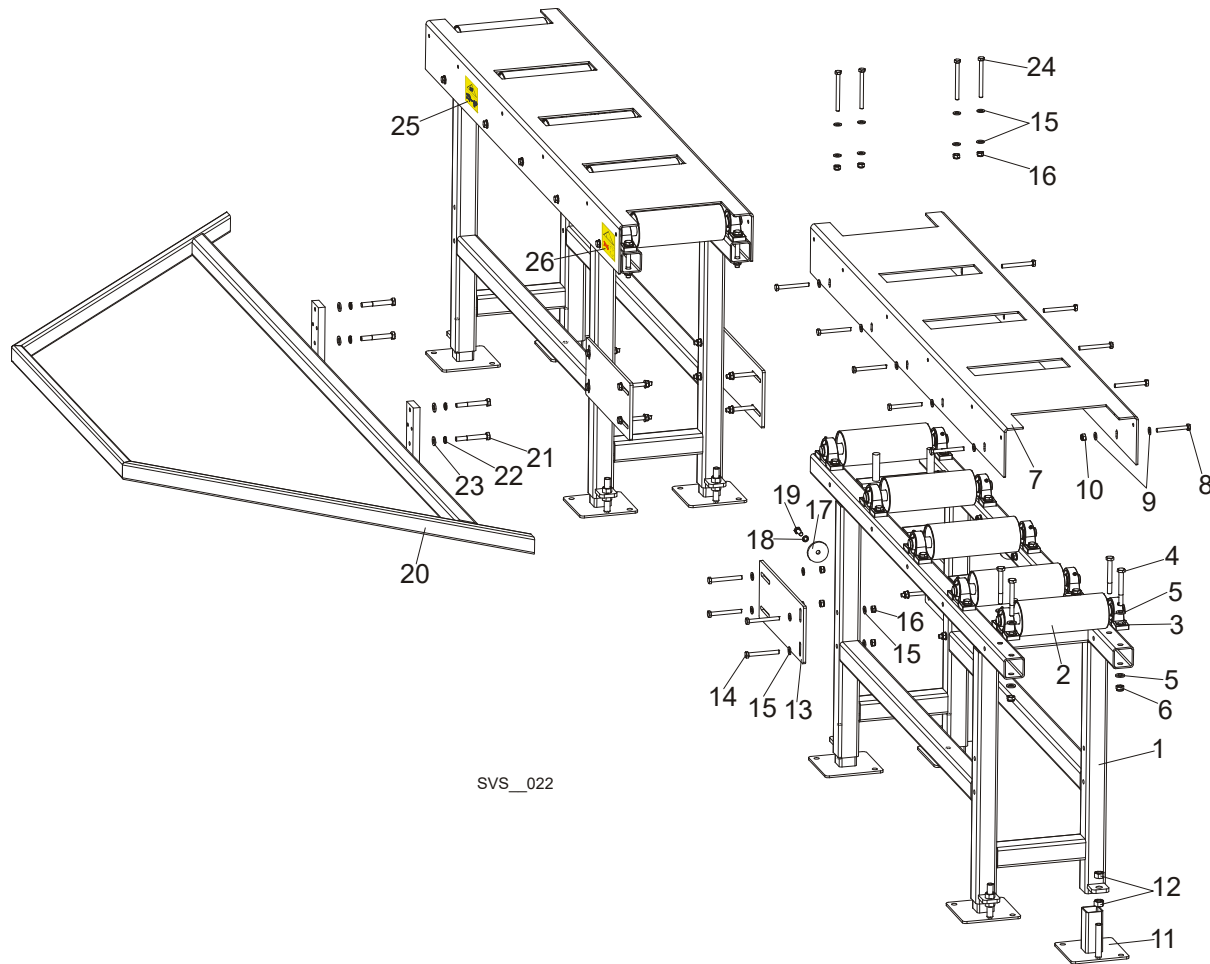

SVS\_022

REF	DESCRIPTION (◆ Indicates Parts Available In Assemblies Only)	PART #	QTY.
	<b>SVS INFEED &amp; OUTFEED TABLE</b>	099170	2
1	FRAME, SVS INFEED & OUTFEED TABLE	099168-1	1
2	ROLLER, SVS FEED	098140-1	5
3	BEARING, UCP 205 CX W/HOUSING	088468	10
4	BOLT, M12x100-8.8 HEX HEAD ZINC	F81004-3	20
5	WASHER, 13 FLAT ZINC	F81056-1	40
6	NUT, M12-8 HEX NYLON ZINC LOCK	F81034-2	20
7	PLATE, SVS TABLE TOP	099167-1	1
8	BOLT, M10x90 -8.8-B HEX HEAD ZINC	F81003-66	10
9	WASHER, 10.5 FLAT ZINC	F81055-1	20
10	NUT, M10-8-B HEX NYLON ZINC LOCK	F81033-1	10
11	FOOT ASSEMBLY, TABLE LEG	099281-1	4
12	NUT, M16-5.8 HEX ZINC	F81036-1	8
13	<b>PLATE, TABLE MOUNTING</b>	099177-1	4
14	<b>BOLT, M10X90 -8.8-B HEX HEAD ZINC</b>	F81003-66	16
15	<b>WASHER, 10.5 FLAT ZINC</b>	F81055-1	40

16	NUT, M10-8-B HEX NYLON ZINC LOCK	F81033-1	16	
17	WASHER, IDLE BLADE WHEEL RETAINING ZINC-PLATED	088957-1	2	
18	WASHER, 10.2 SPLIT LOCK ZINC	F81055-2	2	
19	BOLT, M10X30-5.8 HEX HEAD FULL THREAD ZINC	F81003-2	2	
20	FENCE, SVS	098322-1	1	
21	BOLT, M12X90-8.8 HEX HEAD ZINC	F81004-2	4	
22	WASHER, Z12.2 SPLIT LOCK ZINC	F81056-2	4	
23	WASHER, 13 FLAT ZINC	F81056-1	4	
24	BOLT, M10X110 8.8 HEX HEAD ZINC	F81003-43	4	
25	DECAL, KEEP A SAFE DISTANCE AWAY	099221	1	
26	DECAL, GEAR WARNING	099540	1	

**5.4 Side Table (Optional)**

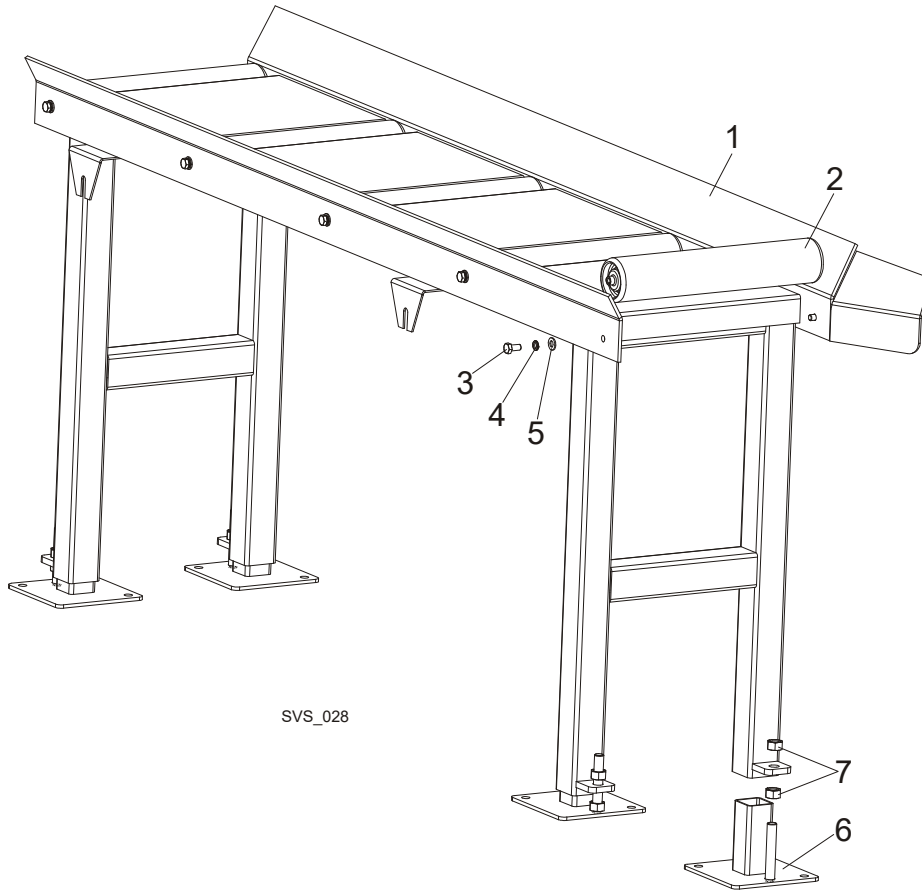

SVS\_028

REF	DESCRIPTION (◆ Indicates Parts Available In Assemblies Only)	PART #	QTY.
	<b>TABLE, SVSST SIDE</b>	098720	1
1	TABLE, SVSST SIDE	098730-1	1
2	ROLLER, 76 DIA. X 400 W/INTERNAL THREAD	093787-1	5
3	BOLT, M10x20-5.8 HEX HEAD FULL THREAD ZINC	F81003-1	10
4	WASHER, 10.2 SPLIT LOCK ZINC	F81055-2	10
5	WASHER, 10.5 FLAT ZINC	F81055-1	10
6	FOOT ASSEMBLY, TABLE LEG	099281-1	4
7	NUT, M16-5.8 HEX ZINC	F81036-1	8