

user manual

Instrukcja obsługi | Руководство пользователя
Manuel de l'Utilisateur | Betriebsanweisung
Bruksanvisning | Manual del Usuario
Betjeningsvejledning | Gebruikershandleiding
Käyttöohjeet | Manual de utilizare | Bruksanvisning
Manuale d'uso | Příručka uživatele

Zachować do przyszłego użytku
Сохраните для последующего использования
A conserver pour une utilisation future
Für zukünftige Benutzung aufbewahren
Behold for senere bruk
Säilytä nämä käyttöohjeet tulevaa tarvetta marten
Opbevar manualen til fremtidig brug
Bewaren voor gebruik in de toekomst
Conservare il presente manuale a l'uso futuro
Păstrați acest manual pentru utilizare viitoare
Conservar para futuras consultas
Uchovajte pro další použití

Single Vertical Saw SVS

Safety, Operation, Maintenance Manual

SVSE11S
SVSE15S

rev.A2.00
rev.A2.00



Safety is our #1 concern! Read and understand all safety information and instructions before operating, setting up or maintaining this machine.

September 2007

Form #1008

Table of Contents

Section-Page

SECTION 1	SAFETY	1-1
1.1	Safety Symbols.....	1-1
1.2	Safety Instructions.....	1-2
SECTION 2	OPERATION	2-1
2.1	Control Overview.....	2-1
2.2	SVS Setup.....	2-3
2.3	Replacing The Blades.....	2-5
2.4	Tensioning The Blade.....	2-6
2.5	Tracking The Blade.....	2-7
2.6	Machine Start.....	2-8
2.7	Cutting Position Setting.....	2-12
2.8	The LubeMizer System.....	2-13
2.9	Operation Procedure.....	2-15
SECTION 3	MAINTENANCE	3-1
3.1	Wear Life.....	3-1
3.2	Blade Guides.....	3-2
3.3	Sawdust Removal.....	3-2
3.4	Miscellaneous Lubrication.....	3-3
3.5	Blade Tensioner.....	3-4
3.6	Belts.....	3-4
3.7	Drive Belt Adjustment.....	3-5
3.8	Feed Chains Tension.....	3-8
3.9	Lube Mizer System.....	3-14
SECTION 4	ALIGNMENT	4-1
4.1	Alignment Procedure.....	4-1
SECTION 5	SPECIFICATIONS	5-1
5.1	Overall Dimensions.....	5-1
5.2	Cutting Capacity.....	5-3
5.3	Blade Motor Specifications.....	5-4
5.4	Electrical Diagram.....	5-5
5.5	Electrical Component List, SVS.....	5-6
5.6	Dust Extractor Specifications.....	5-7
SECTION 6	DC ELECTROMAGNETIC BRAKE	6-1
6.1	Design and Principle of Operation.....	6-1
6.2	Service.....	6-2

If You Need To Order Parts...

From Europe call our European Headquarters and Manufacturing Facility in Kolo-Poland, Nagorna 114 St., at **+48-63-2626000** or **+48-3912-1319**. From the continental U.S., call our toll-free Parts hotline at **1-800-448-7881**. Please have the vehicle identification num-

Table of Contents

Section-Page

ber and your customer number ready when you call. Wood-Mizer will accept these methods of payment:

- Visa, Mastercard, or Select Purchase
- COD
- Prepayment
- Net 15 (with approved credit)

Be aware that shipping and handling charges may apply. Handling charges are based on size and quantity of order. In most cases, items will ship on the day they are ordered. Second Day and Next Day shipping are available at additional cost.

If You Need Service...

From Europe call our European Headquarters and Manufacturing Facility in Kolo-Poland, Nagorna 114 St. at **+48-63-2626000** or **+48-3912-1319**. From the continental U.S., call us toll-free at **1-800-525-8100**. Ask to speak with a Customer Service Representative. Please have your vehicle identification number and your customer number ready when you call. The Service Representative can help you with questions about alignment of your mill, blade sharpening, or cutting a particular species of wood. He also can schedule you for a service call.

Office Hours: All times are Eastern Standard Time. Please remember that Indiana does not go on Daylight Savings Time in the summer.

Country	Monday - Friday	Saturday	Sunday
U.S., Indiana	8 a.m. to 5 p.m.	8 a.m. to 4 p.m.	Closed
Poland	8 a.m. to 4:30 p.m.	8 a.m. to 1 p.m.	Closed



IMPORTANT! Read the entire Operator's Manual before operating the sawmill. Take notice of all safety warnings throughout this manual and those posted on the machine. Keep this manual with this machine at all times, regardless of ownership.

SECTION 1 SAFETY

1.1 Safety Symbols

The following symbols and signal words call your attention to instructions concerning your personal safety. Be sure to observe and follow these instructions.



DANGER! indicates an imminently hazardous situation which, if not avoided, will result in death or serious injury.



WARNING! suggests a potentially hazardous situation which, if not avoided, could result in death or serious injury.



CAUTION! refers to potentially hazardous situations which, if not avoided, may result in minor or moderate injury or damage to equipment.



IMPORTANT! indicates vital information.

NOTE: gives helpful information.



Warning stripes are placed on areas where a single decal would be insufficient. To avoid serious injury, keep out of the path of any equipment marked with warning stripes.

1.2 Safety Instructions

NOTE: ONLY safety instructions regarding personal injury are listed in this section. Caution statements regarding only equipment damage appear where applicable throughout the manual.

Observe Safety Instructions



IMPORTANT! Read the entire Operator's Manual before operating the machine. Take notice of all safety warnings throughout this manual and those posted on the machine. Keep this manual with this machine at all times, regardless of ownership.

Also read any additional manufacturer's manuals and observe any applicable safety instructions including dangers, warnings, and cautions.

Only persons who have read and understood the entire operator's manual should operate the machine. The machine is not intended for use by or around children.

IMPORTANT! It is always the owner's responsibility to comply with all applicable national and local laws, rules and regulations regarding the ownership and operation of your Wood-Mizer Twin Vertical Saw. All Wood-Mizer TVS/SVS owners are encouraged to become thoroughly familiar with these applicable laws and comply with them fully while using the machine.



Wear Safety Clothing



WARNING! Secure all loose clothing and jewelry before operating the machine. Failure to do so may result in serious injury or death.

WARNING! Always wear gloves and eye protection when handling bandsaw blades. Changing blades is safest when done by one person! Keep all other persons away from area when coiling, carrying or changing a blade. Failure to do so may result in serious injury.

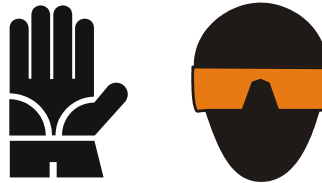

WARNING! Always wear eye, ear, respiration, and foot protection when operating or servicing the machine.



Keep the Machine And Area Around Clean



DANGER! Maintain a clean and clear path for all necessary movement around the machine and lumber stacking areas. Failure to do so will result in serious injury.

Dispose Of Sawing By-Products Properly



IMPORTANT! Always properly dispose of all sawing by-products, including sawdust and other debris.

CAUTION! The sawmill's work-stand should be equipped with a 4 kg or bigger dry powder extinguisher.

Check the Machine Before Operation

 **DANGER!** Make sure all guards and covers are in place and secured before operating the machine. Failure to do so may result in serious injury.



Keep Persons Away

 **DANGER!** Keep all persons out of the path of moving equipment and lumber when operating the machine. Failure to do so will result in serious injury.

DANGER! Always be sure all persons are out of the path of the blade before starting the motor. Failure to do so will result in serious injury.

 **WARNING!** Allow blade to come to a complete stop before opening the blade housing cover. Failure to do so will result in serious injury.

Keep Hands Away



DANGER! Always shut off the blade motor before changing the blade. Failure to do so will result in serious injury.

DANGER! Motor components can become very hot during operation. Avoid contact with any part of a hot motor. Contact with hot motor components can cause serious burns. Therefore, never touch or perform service functions on a hot motor. Allow the motor to cool sufficiently before beginning any service function.

DANGER! Always keep hands away from moving bandsaw blade. Failure to do so will result in serious injury.

DANGER! Always be aware of and take proper protective measures against rotating shafts, pulleys, fans, etc. Always stay a safe distance from rotating members and make sure that loose clothing or long hair does not engage rotating members resulting in possible injury.



WARNING! Use extreme caution when spinning the blade wheels by hand. Make sure hands are clear of blade and wheel spokes before spinning. Failure to do so may result in serious injury.

Use Proper Maintenance Procedures



DANGER! Make sure all electrical installation, service and/or maintenance work is performed by a qualified electrician and is in accordance with applicable electrical codes.

DANGER! Hazardous voltage inside the electric boxes and at the motor can cause shock, burns, or death. Disconnect and lock out power supply before servicing! Keep all electrical component covers closed and securely fastened during machine operation.



WARNING! Consider all electrical circuits energized and dangerous.

WARNING! Disconnect and lock out power supply before servicing! Failure to do so may result in serious injury.

WARNING! Never assume or take the word of another person that the power is off; check it out and lock it out.

WARNING! Do not wear rings, watches, or other jewelry while working around an open electrical circuit.

WARNING! Remove the blade before performing any service to the motor. Failure to do so may result in serious injury.



DANGER! Operator can not for any reason perform any laser maintenance or repair work.



DANGER! Never clean the blade or blade wheels using the hand-held brush or scraper whilst the saw blade is in motion.

1 SAFETY
Keep Safety Labels In Good Condition

Keep Safety Labels In Good Condition



IMPORTANT! Always be sure that all safety decals are clean and readable. Replace all damaged safety decals to prevent personal injury or damage to the equipment. Contact your local distributor, or call your Customer Service Representative to order more decals.

IMPORTANT! If replacing a component which has a safety decal affixed to it, make sure the new component also has the safety decal affixed.

Fire-Fighting

CAUTION! The sawmill's work-stand should be equipped with a 4 kg or bigger dry powder extinguisher.

Safety Labels Description

See Table 1-1. See table below for safety labels description.

TABELA 1-1





Decals View	Decal No.	Description
	096317	Carefully read operator's manual before handling the machine. Observe instructions and safety rules when operating.

TABELA 1-1

	<p>099220</p>	<p>Close guards prior to operating the machine</p>
	<p>099219</p>	<p>Blade tension adjustment. Turn right to tighten, turn left to release.</p>
	<p>099221</p>	<p>Keep safe distance when the machine is operating.</p>

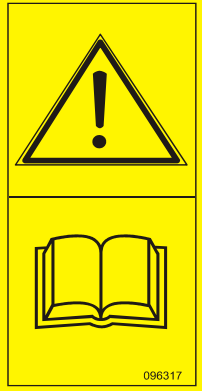
1 SAFETY
Safety Labels Description

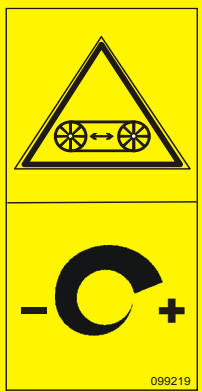
TABELA 1-1





	<p>096314</p>	<p>Keep safe distance when the machine is operating.</p>
	<p>096316</p>	<p>Electric box opening is possible with the switch in "0" position only.</p>
	<p>096319</p>	<p>Always disconnect the power cord before opening the electric box.</p>

TABELA 1-1

	<p>098177</p>	<p>Always disconnect the power cord before performing any service.</p>
	<p>099540</p>	<p>CAUTION! Gear train - Keep safe distance!</p>
	<p>096321</p>	<p>Blade movement direction.</p>
	<p>500031</p>	<p>CAUTION! Do not adjust turnbuckles!</p>

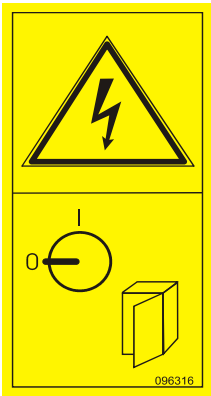
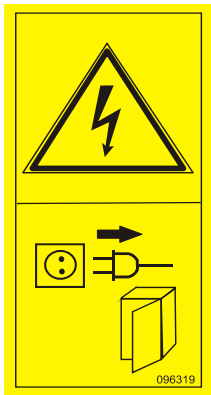
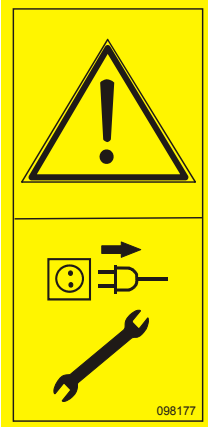
1 SAFETY
Safety Labels Description

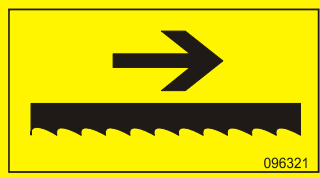
TABELA 1-1





	<p>S12004G</p>	<p>Always wear eye protection equipment when operating this machine</p>
	<p>S12005G</p>	<p>Always wear ear protection equipment when operating this machine</p>
	<p>501465</p>	<p>CAUTION! Always wear safety boots when operating the sawmill</p>
	<p>501467</p>	<p>Lubrication Point</p>
 <p>P11789/PL</p>	<p>P11789</p>	<p>Blade alignment. Turn right to move the blade out on wheel; turn left to move the blade in on wheel.</p>

TABELA 1-1

	<p>092597</p>	<p>Blade tension adjustment. See Section 2.4</p>
	<p>P85070</p>	<p>CE certified machine.</p>
	<p>S20097</p>	<p>Motor rotation direction.</p>
	<p>099504</p>	<p>Visible and/or invisible laser radiation. Avoid eye or skin exposure to direct or scattered radiation.</p>

SECTION 2 OPERATION

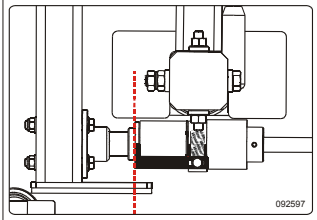
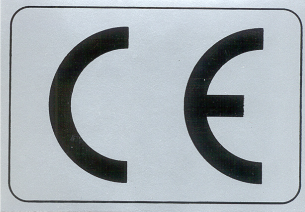
2.1 Control Overview

1. Control Panel

See **Figure 2-1**. The control panel includes switches to start and stop the feed track and the saw heads.

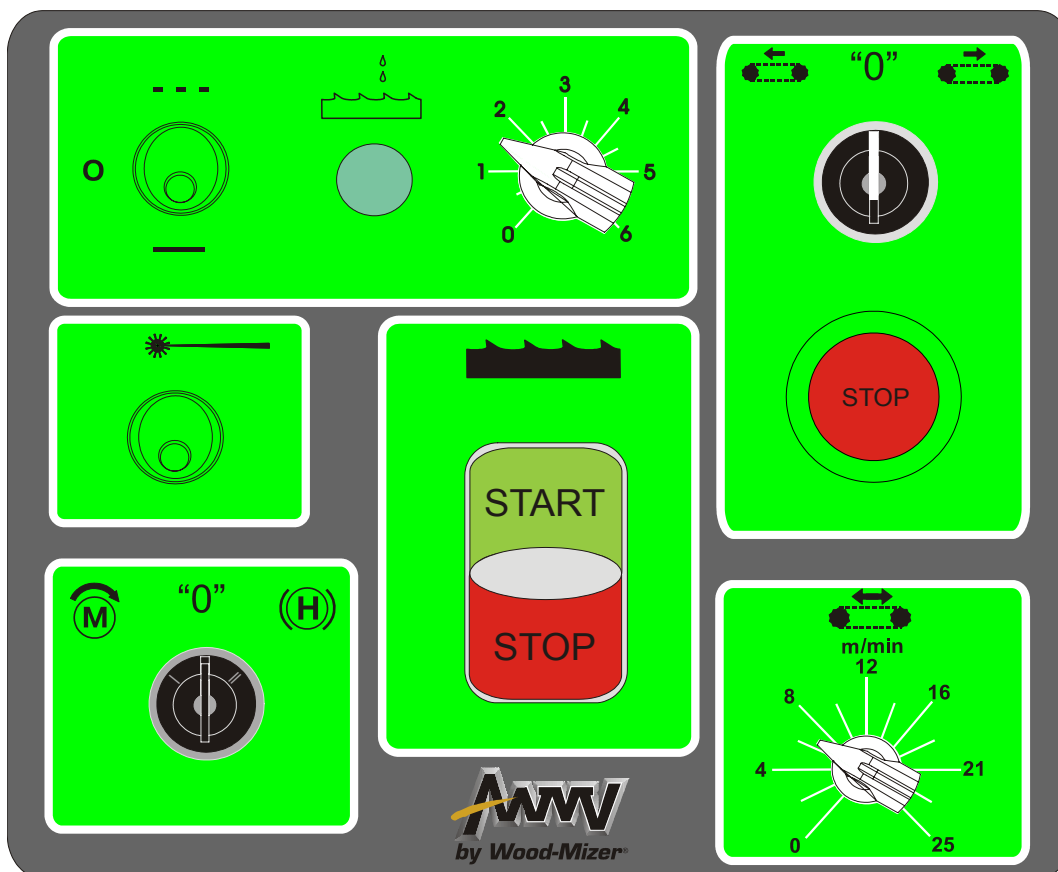

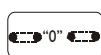

FIG. 2-1 CONTROL PANEL COMPONENTS

2. Blade Drive

 To start the blade motor, turn the key switch to the  position. Then press the START button. To stop the blade motor, press the STOP button.

3. Feed Track

 To start spinning the feed track forward, turn the switch right. To start spinning the feed

backward turn the switch left.



4. Feed Track Speed Adjustment



The feed track speed switch controls the speed at which the feed track moves. Turn the switch right to increase the speed, turn left to reduce the speed.

5. Key Switch

The key switch has three positions:

- “0” position - all electrical circuits are off,
-  position - all electrical circuits are on,
-  position - releases the motors disk brake, the blade and the track feed motors are off.

6. Emergency Stop

Push the emergency stop button to stop the blade and the track feed motors. Turn the emergency stop clockwise to release the stop. The machine will not restart until the emergency stop is released.

7. LMS

8. Laser



2.2 SVS Setup



IMPORTANT! Before starting to use the machine you have to meet the following conditions:

- Set up the machine on firm and level ground.
- The machine can be operated with the sawdust collection system only.
- The machine can be operated under roof only.
- The machine can be operated in temperature range from -15° C to 40° C only.
- The machine operator's position is shown below.

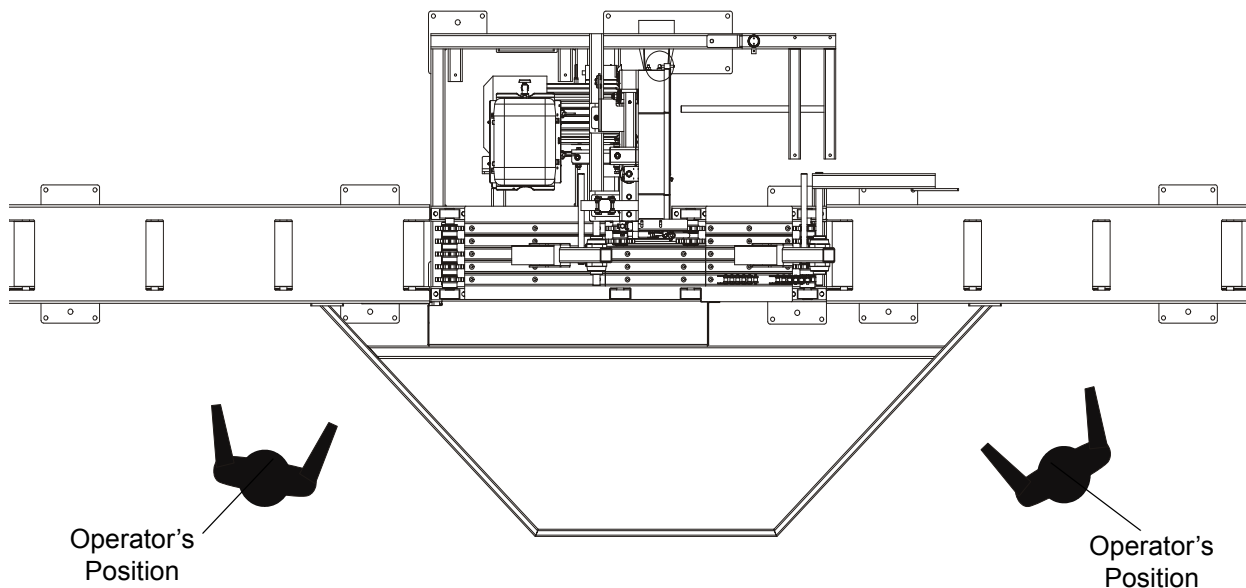

- Have a qualified electrician install the power supply (according to EN 60204 Standard). The power supply must meet the specifications given in the table below.

3-Phase Volts	Fuse Disconnect	Suggested Wire Size
400 VAC	40 Amps	4 mm ² , up to 15 m long

TABLE 2-0

 **IMPORTANT!** When starting the machine for the first time, check that blade rotation direction is as indicated by the arrow located on the blades covers. If the rotation direction is incorrect, invert the phases in the phase inverter located in the power socket (electric box). Setting the phases in the phase inverter correctly will ensure correct rotation directions of all machine motors.

 **IMPORTANT!** When starting the machine for the first time, let it run without any load for 1-2 hours. It will let the infeed and outfeed tables drive components to grind in.

- The resaw can be lifted using the forklift only. Forklift must be rated for at least 2000kg. Resaw is equipped with forklift pockets. Insert the forks into the pockets shown on the picture below.

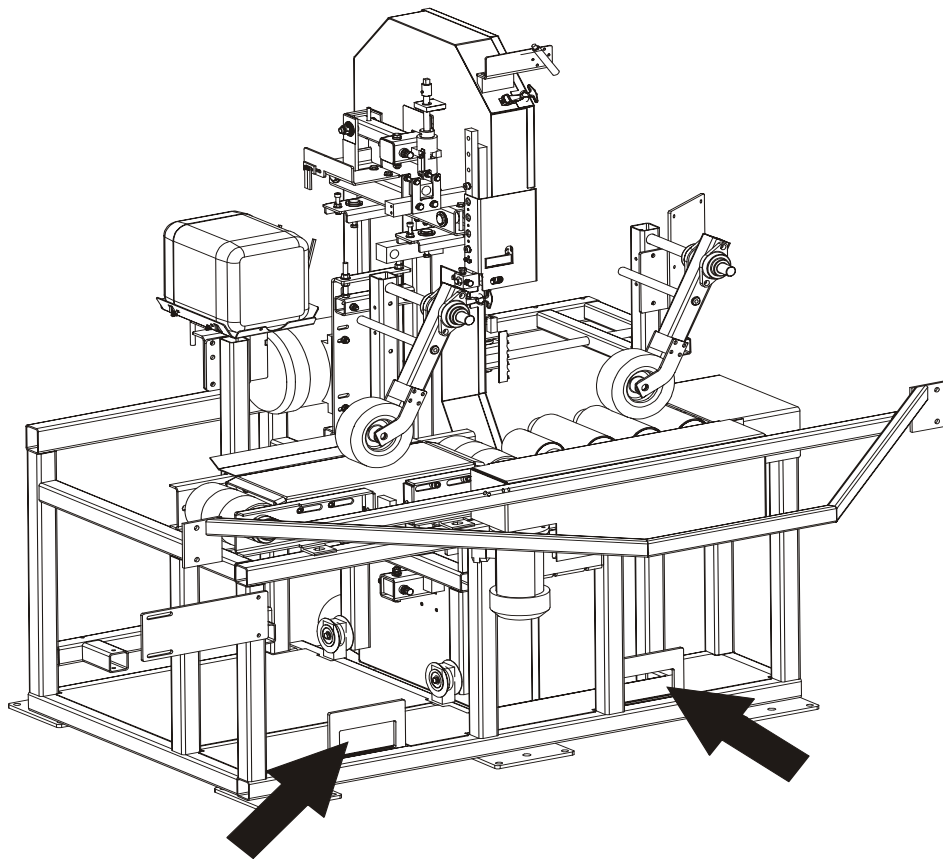

FIG. 2-2

2.3 Replacing The Blades



DANGER! Always shut off the machine motors before changing the blades. Failure to do so may result in serious injury.



WARNING! Always wear gloves and eye protection whenever handling bandsaw blades. Changing blades is safest when done by one person! Keep all other persons away from work area when changing blades. Failure to do so may result in serious injury.

Move the control box arm and next open the blade housing cover. Turn the blade tension handle to release the blade tension until the wheel is pulled in and the blade is lying loose in the blade housing. Lift the blade out of the blade housing.

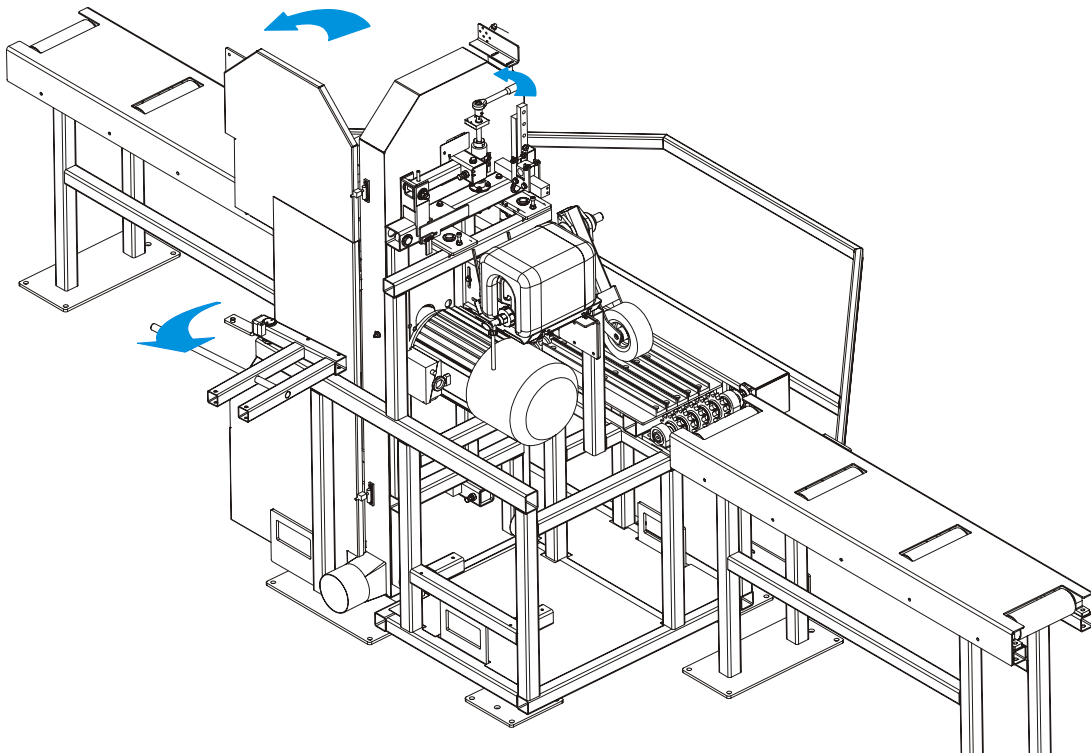

Install a new blade around the two blade wheels so that the teeth located between the blade guide assemblies point to the infeed table. Make sure the teeth are pointing the correct direction.

Position 1 1/4" wide blades on the wheels so the gullet is 3.0 mm (\pm 1.0 mm) out from the front edge of the wheel.

Close the blade housing cover.

Next, tension the blade as described in the following instructions.

2.4 Tensioning The Blade

See **Figure 2-3**. Place the provided handle on the blade tensioner shaft. Turn the handle clockwise until the outside face of the rubber spring washer is even with the indicator (see the figure below). Check the blade tension occasionally when adjusting the cant control or while cutting and adjust if necessary. As the blade and belts heat up and stretch, the blade tension will change. Also, ambient temperature changes can cause tension to change.

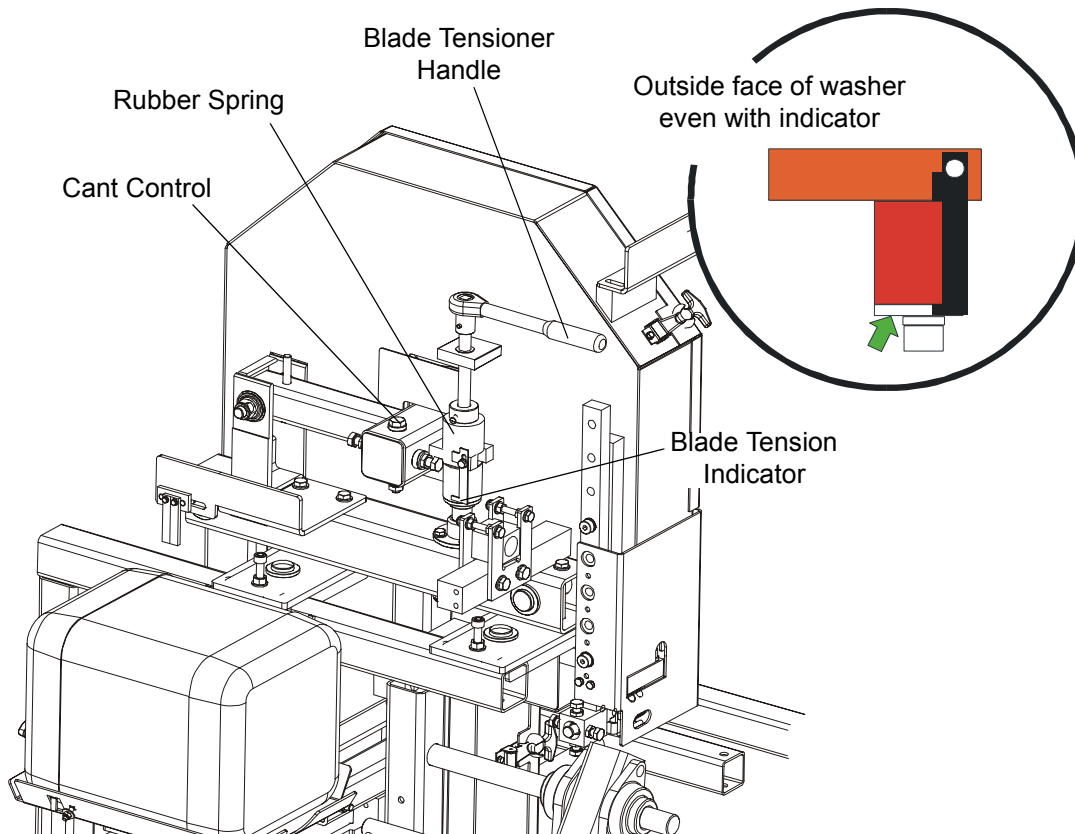

FIG. 2-3



CAUTION! Release the blade tension when the machine is not in use.

2.5 Tracking The Blade

1. Open the blade housing cover of each saw head.
2. Turn the key switch to the "H" position.



3. Manually spin one of the blade wheels until the blade positions itself on the blade wheels.
4. Check that the blade is properly positioned on the blade wheels.

See **Figure 2-4**. 1 1/4" wide blades should be placed on the blade wheels so that the

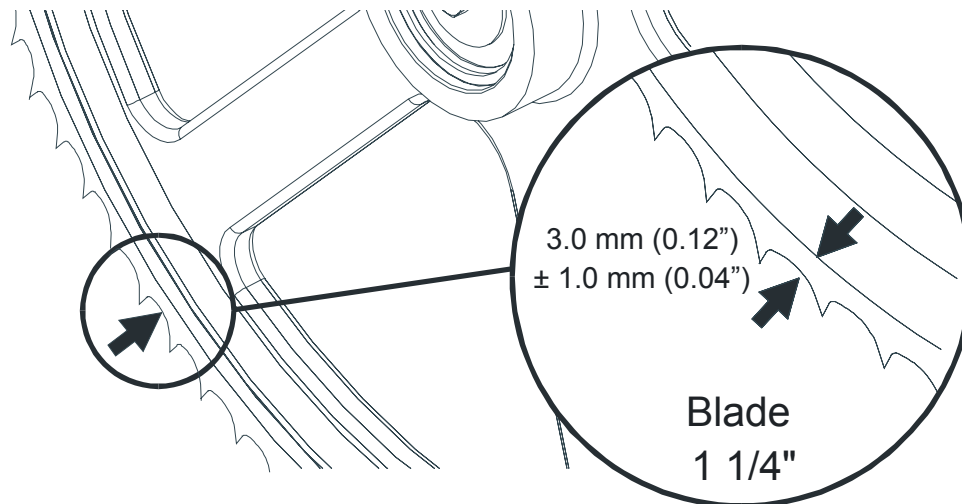

FIG. 2-4

gullet is 3.0 mm (0.12") ± 1.0 mm (0.04") out from the front edge of the wheel.

5. Use the cant adjustment bolt, shown in **Figure 2-3**, to adjust where the blade travels on the blade wheels.

To move the blade out on the blade wheel, turn the cant adjustment bolt clockwise. To move the blade in on the blade wheel, turn the bolt counterclockwise.

6. Adjust the blade tension if necessary to compensate for any changes that may have occurred while adjusting the cant control.
7. Close the blade housing cover.



CAUTION! Make sure all guards and covers are in place and secured before operating or towing the machine.

Failure to do so may result in serious injury. Be sure the blade housing cover is in place and secured.

NOTE: After aligning the blade on the wheels, always check the blade guide spacing and location.

2.6 Machine Start



DANGER! Before starting the machine, perform these steps to avoid injury and/or damage to the equipment:

- Close the blade housing covers and replace any guards removed for service.
- Check the feed track and remove all loose objects such as tools, wood, etc.
- Check that the blades are properly tensioned.
- Make sure all persons are a safe distance from the machine.
- Check that the emergency stops are released.

NOTE: The machine will not start if either of the emergency stops is on.

Before starting the saw head, check that the main power switch servicing the machine is on.

See Figure 2-5. Start the blade motors. To do this, turn the key switch to the  position and then push the Blade START button on the control panel (see the figure below). The motor should start and the blade should start spinning.

2 Operation

Machine Start

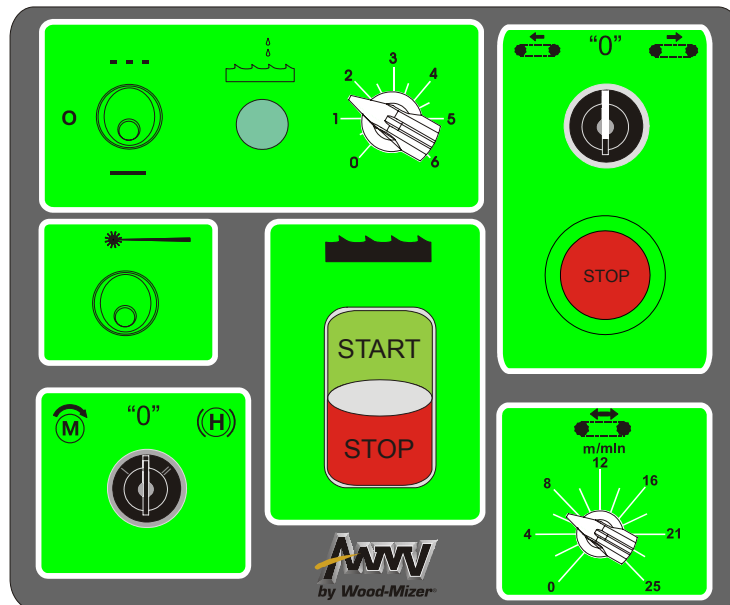

FIG. 2-5

To stop the blade motor, push the Blade Stop button shown in the figure above. The blade motor also may be stopped by pushing either of the emergency stop buttons.

If either of the emergency switch has been used to stop the blade motor, rotate the switch clockwise before restarting the saw head. The saw head cannot be restarted until the emergency stop button is released.

See Figure 2-6. After the saw head has been successfully started, the feed track can be

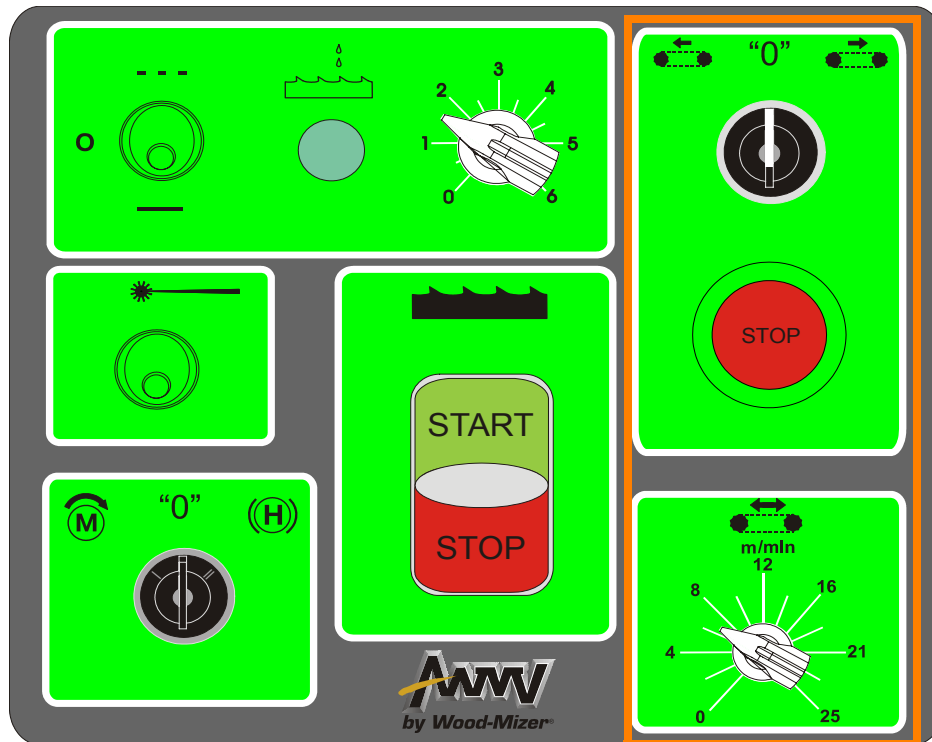

FIG. 2-6

started. To start the track chain motor, turn the Track Start switch (shown in Figure 2-6) left to start the track forward, turn the switch right to start the track backward. Press the STOP button to stop the track.

The feed track can be stopped by pressing one of the emergency stop buttons. The emergency stop will also stop the blade motor.

NOTE: The feed track cannot be started if the blade motor is not started.

The speed at which the feed track moves is adjustable. The feed track speed switch, located on the control panel (shown in Figure 2-6), allows the operator to adjust the feed rate from 0 to ca. 25 m per minute.

Turn the switch right to increase the feed rate, left to slow the feed rate down.

Factors that will determine what feed rate you can use include:

- Log diameter.

2

Operation

Machine Start

- Hardness of material to be cut. Some woods that are seasoned or naturally very hard will require slower feed rates.
- Sharpness of blades. Dull or improperly sharpened blades will require slower feed rates than sharp and properly maintained blades.
- Off-bearing capability. Your ability to feed will also determine what feed rate you can use.

2.7 Cutting Position Setting

1. Install a blade if needed and check for correct blade tension. ([See Section 2.4 Tensioning The Blade](#))
2. Place the material to be cut on the infeed table.
3. The laser beam is showing the cutting position.



DANGER! Visible and/or invisible laser radiation. Avoid eye or skin exposure to direct or scattered radiation.

See Figure 2-7. .

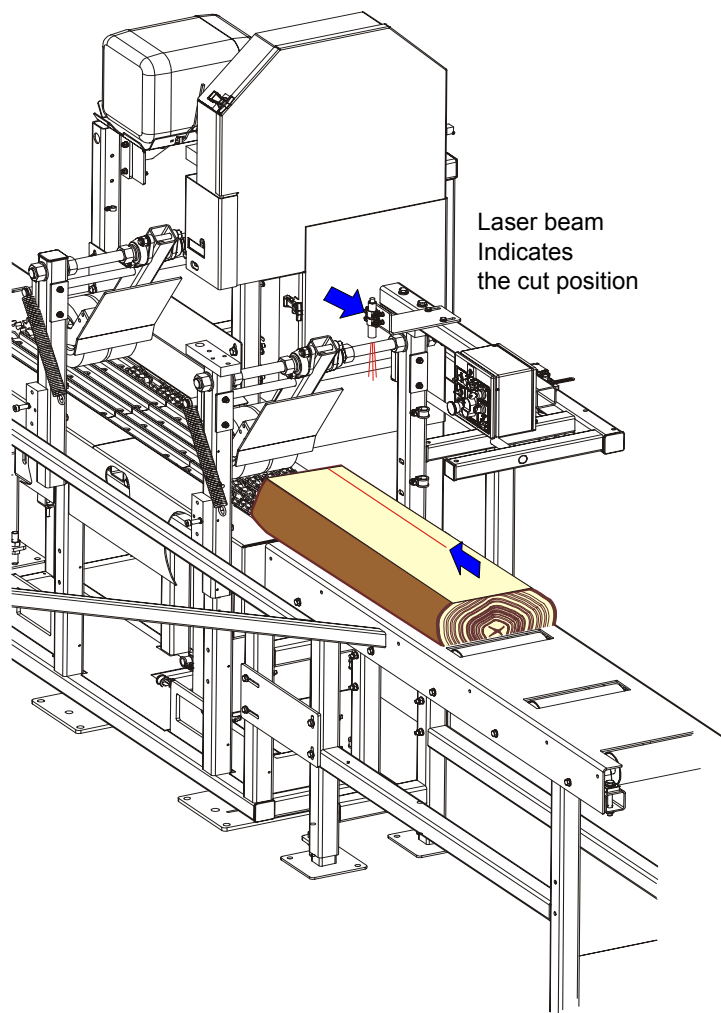

FIG. 2-7

2.8 The LubeMizer System

Lube Mizer system is used to lubricate the blade during sawing. The LubeMizer applies lubricant on both sides of the blade as you are sawing to reduce resin buildup on the blade. The LubeMizer controls allow you to adjust the volume of lubricant for various wood types. The LubeMizer option uses less volume than the standard Water Lube, helping to reduce lubricant/sawdust mess and waste, and to prevent stained boards.

Usual flow will be between 2.6 - 9.5 liters per hour.

1. To start the self-priming system,
 - Open the water lube bottle valve all the way.
 - Turn the lube control switch to PULSE¹ and set the lube dial to the desired flow rate. Use the lowest setting that successfully eliminates pitch buildup.

NOTE: Softwood applications will usually require more lubricant than hardwood applications.

2. Cut the log.
3. To shut of the lube,
 - Turn the lube control switch to OFF.
 - Close the lube bottle valve all the way.
4. If you are sawing or storing the machine in freezing temperatures, use windshield washer fluid to help prevent the water from freezing.



CAUTION! Add windshield washer fluid to the water tank and prime as recommended when sawing or storing the machine in below-freezing temperatures. Use windshield washer fluid with a freezing point of at least -20°F (-29°C). Failure to do so will cause damage to the LubeMizer system may result.

Lube Additives

For further benefits, add one 12oz. bottle of Wood-Mizer Lube Additive to a 5 gallon jug of water. Wood-Mizer Lube Additive enables some previously impossible timbers to be cut

¹Pulse is suitable for most cutting applications. CONTINUOUS delivers a steady stream of lubricant and should be used only for heavy pitch buildup or occasional blade cleaning.

by significantly reducing resin buildup on the blade. It helps to reduce heat buildup, wavy cuts, and blade noise. This biodegradable and environmentally friendly pre-mix includes a water softener additive, so it works with hard water.



WARNING! Use ONLY water, Wood-Mizer Lube Additive or windshield washer fluid with the water lube accessory. Never use flammable fuels or liquids such as diesel fuel. If these types of liquids are necessary to clean the blade, remove it and clean with a rag. Failure to do so can damage the equipment and may result in serious injury or death.

See Table 2-1. Use windshield washer fluid as an antifreeze to prevent the water from freezing and damaging the LubeMizer system. See the chart below for recommended mixture levels depending on the temperature where you are sawing or storing the machine.

Run the LubeMizer system on the “Continuous” setting for 30 seconds after adding the windshield washer fluid to the system. This will insure the water throughout the system will not freeze and damage the check valves.



CAUTION! Add windshield washer fluid to the water tank and prime as recommended when sawing or storing the sawmill in below-freezing temperatures. Use windshield washer fluid with a freezing point of at least -20°F (-29°C). Failure to do so may cause damage to the LubeMizer system.

Ratio WWF ¹ :Water to fill 5 Gal. tank	Freezing Point Of Solution	
	(°F)	(°C)
5:0	-22	-30
4:1	-3	-19
3:2	7	-14
2.5:2.5	13	-10
1:4	24	-4
0:5	32	0

TABLE 2-1

¹ WWF = Windshield Washer Fluid with -20°F (-29°C) freezing point.

2.9 Operation Procedure

1. Install a blade if necessary.



WARNING! Always wear gloves and eye protection when handling bandsaw blades. Changing blades is safest when done by one person! Keep all other persons away from area when coiling, carrying or changing a blade. Failure to do so may result in serious injury.

2. Close the blade housing cover.
3. Tension the blade as described in [See Section 2.4 Tensioning The Blade](#).
4. Slowly spin the blade wheel by hand.



WARNING! Use extreme caution when spinning the blade wheel by hand. Make sure hands are clear of blade and wheel spokes before spinning. Failure to do so may result in serious injury.

5. Check alignment of the blade on the blade wheels and blade guides. Adjust as necessary.



DANGER! Make sure all guards and covers are in place and secured before operating the machine. Failure to do so may result in serious injury.

6. Perform pre-start check. [See Section 2.2 SVS Setup](#)
7. Start the blade motor.
8. Using the feed track speed switch, set the feed rate as desired.



DANGER! Always be sure all persons are out of the path of the blade before starting the motor. Failure to do so will result in serious injury.



WARNING! Always wear eye, ear, respiration and foot protection when operating or servicing your machine.

9. Place the test material on the feed track and start the feed track.



DANGER! Always be aware of and take proper protective measures against rotating shafts, pulleys, fans, etc. Always

stay a safe distance from rotating members and make sure that loose clothing or long hair does not engage rotating members resulting in possible injury.

10. Monitor blade tension as operation continues. Adjust blade tension if required.
11. If material jam occurs, stop the blade motor and feed track.



WARNING! Allow blade to come to a complete stop before servicing. Failure to do so will result in serious injury.

12. After operation is complete, shut off the blade motor and feed track.
13. Release blade tension if done sawing for the day.



CAUTION! Remove tension from the blade when the machine is not in use.

SECTION 3 MAINTENANCE

This section lists the maintenance procedures that need to be performed.



This symbol identifies the interval (hours of operation) at which each maintenance procedure should be performed.

Be sure to refer to the motor manual for maintenance procedures concerning the blade motor.

3.1 Wear Life

See Table 3-1. This chart lists estimated life expectancy of common replacement parts if proper maintenance and operation procedures are followed. Due to the many variables which exist during resaw operation, actual part life may vary significantly. This information is provided so that you may plan ahead in ordering replacement parts.

Part Description	Estimated Life
B57 Blade Wheel Belts	500 hours
Blade Guide Rollers	1000 hours
Drive Belt	1250 hours

TABLE 3-1

3.2 Blade Guides

1. Check the rollers for performance and wear every blade change. Make sure the rollers are clean and spinning freely. If not, rebuild them. Replace any rollers which have worn smooth or have become cone shaped. See the Parts manual for blade guide rebuild kits and complete roller assemblies.

3.3 Sawdust Removal

1. Remove the excess sawdust from the blade wheel housing, sawdust chute, drive chains sprockets and the SVS frame lower plate every blade change.

See Figure 3-1.

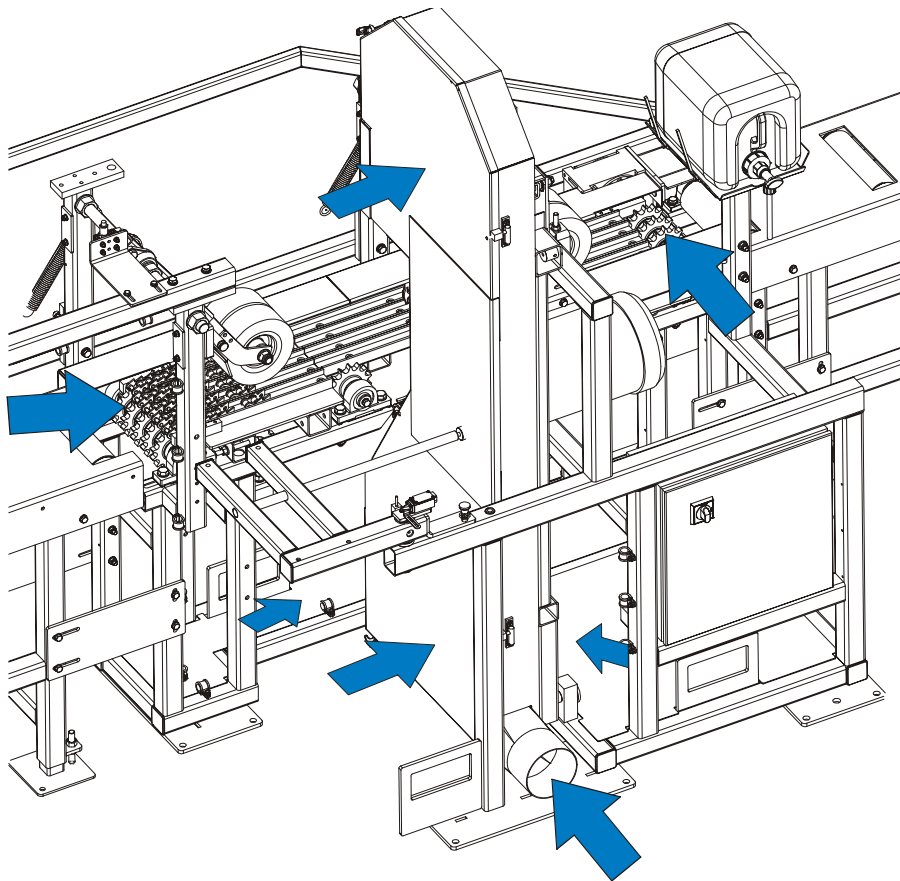

FIG. 3-1

3.4 Miscellaneous Lubrication

1. Using the grease nipples, lubricate chain drive bearings the infeed and outfeed tables bearings, with a lithium grease every 200 hours of operation or once a month.



CAUTION! Never apply grease to the feed track chain. It causes sawdust buildup in chain links.

See Figure 3-2.

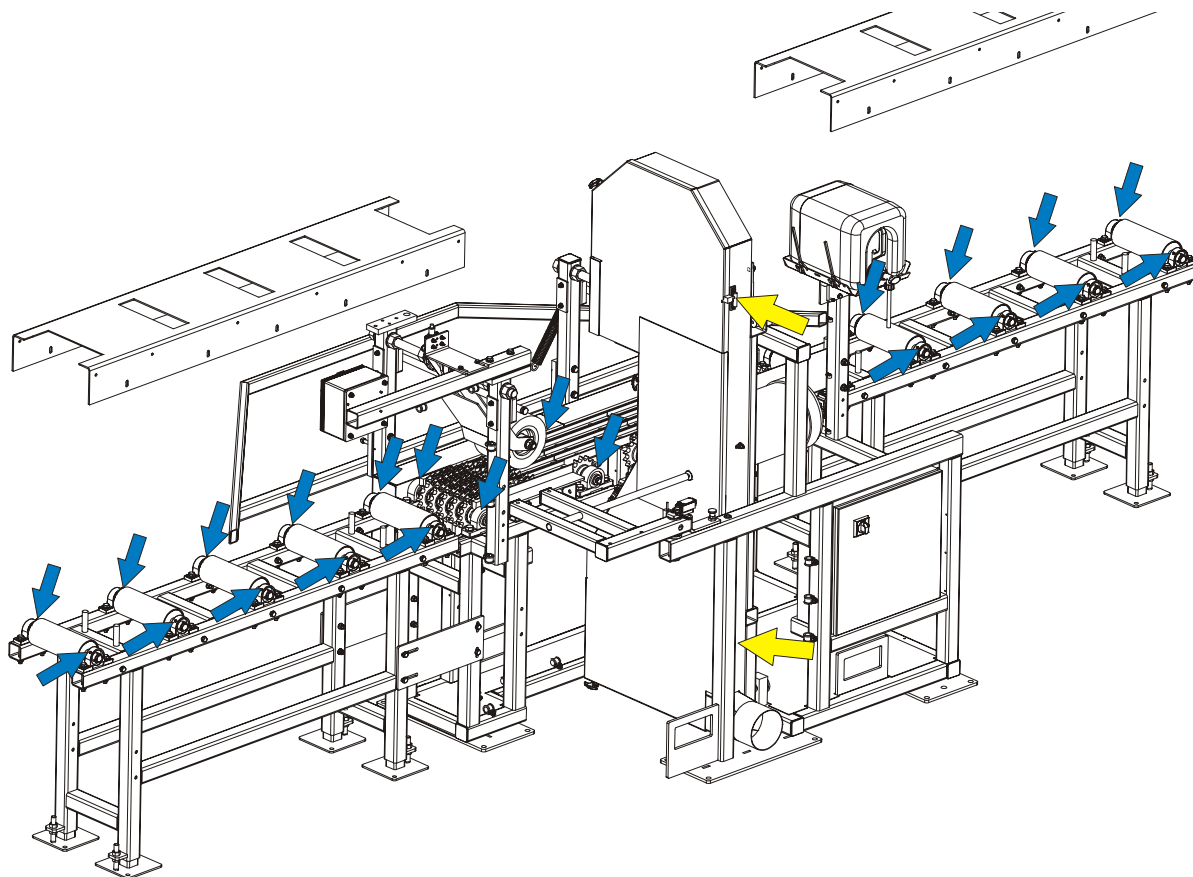

FIG. 3-2

2. Make sure all safety warning decals are readable. Remove sawdust and dirt. Replace any damaged or unreadable decals immediately. Order decals from your Customer Service Representative.

3.5 Blade Tensioner

1. Grease the screw on the blade tensioner shaft with a lithium grease every fifty hours of operation, but at least once a week.

See Figure 3-3.

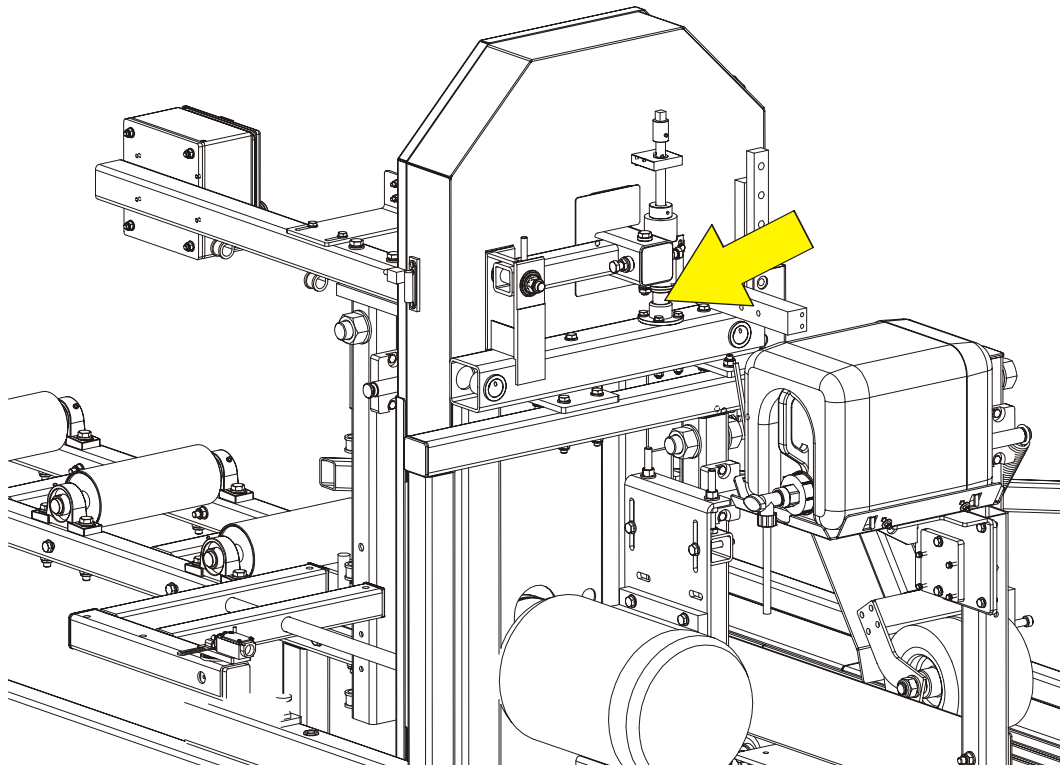



FIG. 3-3

3.6 Belts

1. Check the blade wheel belts for wear every 50 hours of operation. Replace as needed.
2. Periodically check all belts for wear. Replace any damaged or worn belts as needed.

3.7 Drive Belt Adjustment

 **WARNING!** Do not for any reason adjust the drive belt with the motor running. Doing so may result in serious injury.

 See **Table 3-2**. Check the drive belt tension after the first 20 hours, and every 50 hours thereafter. See the table below for drive belt tension specifications for your resaw.

Motor	Belt Tension
E11, E15	17mm deflection with 10 KG of deflection force

TABLE 3-2

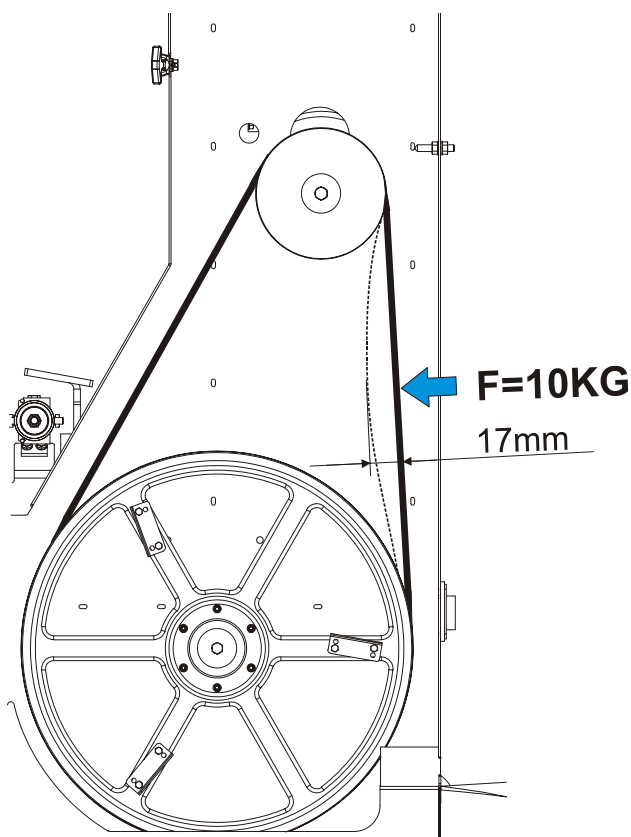

FIG. 3-3

To adjust the drive belt tension:

1. Loosen the four motor mounting bolts (see Figure 3-3).
2. Loosen the lock nuts on the adjustment bolts. Using the adjustment bolts move the motor mounting plate up to tension the drive belt, move the motor plate down to loosen the belt. Next tighten the lock nuts. **NOTE:** Be sure to adjust the bolts evenly so the motor remains in alignment.

3. Tighten the four motor mounting bolts.

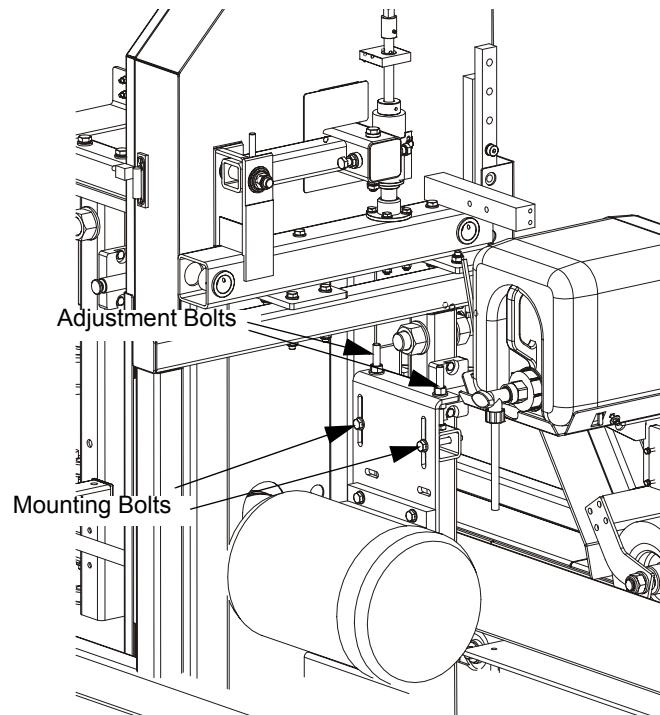

FIG. 3-3



Periodically check the belt for wear. Replace if damaged or worn.

3 MAINTENANCE

Drive Belt Adjustment

See Figure 3-4. Keep the motor and drive pulleys aligned to prevent premature belt wear. To align the motor pulley to the drive pulley, loosen the mounting bolts on the motor plate and slide the motor plate in or out until it is in line with the drive pulley. After performing the alignment, make sure the drive belt tension has not been changed.

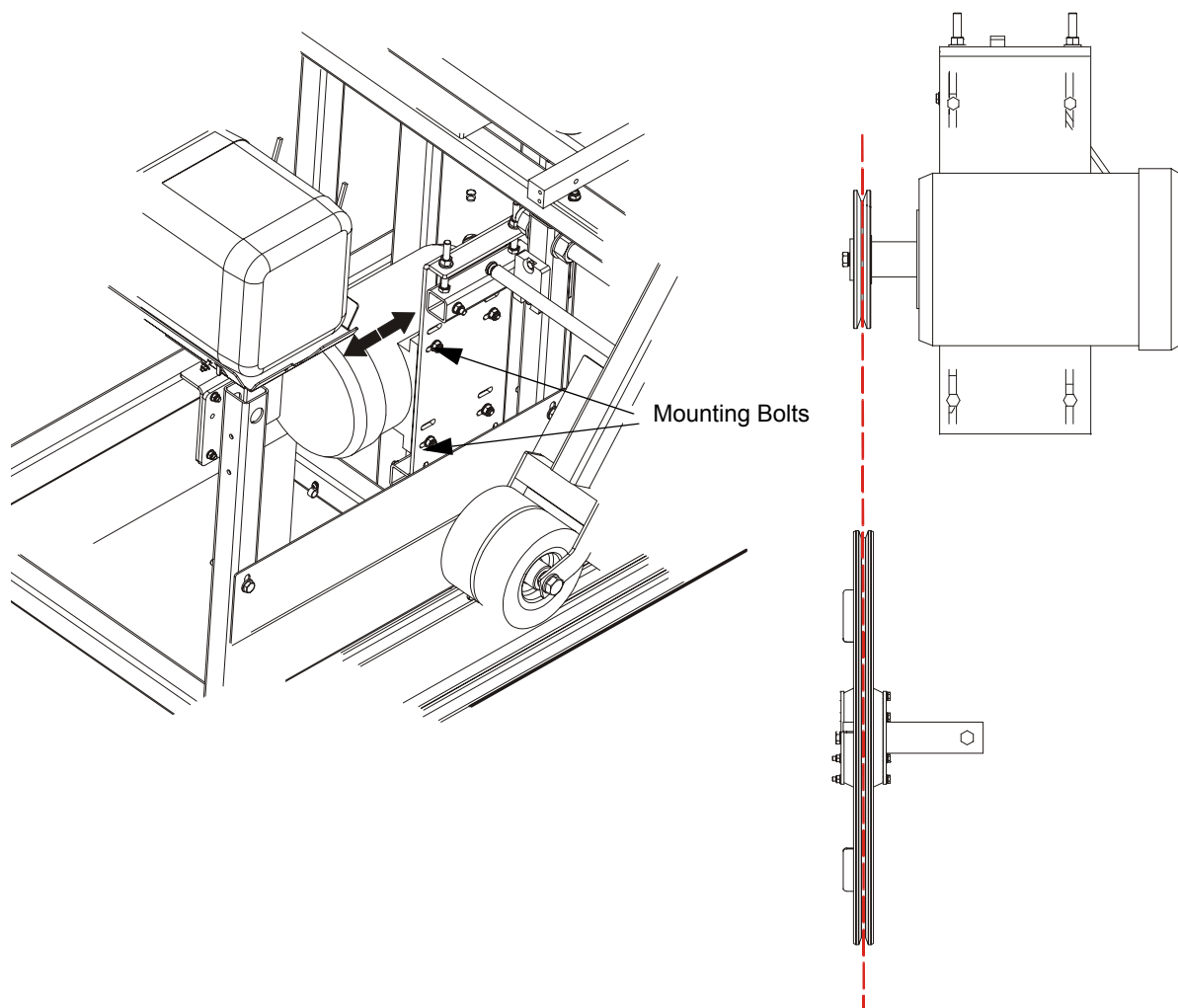

FIG. 3-4

3.8 Feed Chains Tension

If necessary, use the adjustment bolts shown below to adjust the feed chains tension. The chains should lay freely on the upper bars.

CAUTION! Do not over-tension the chains. Over-tensioning may lead to early failure of the gear, bearings, rollers and chains.

WARNING! Disconnect and lock out power supply before servicing! Failure to do so may result in serious injury.

1. Dismount the infeed table.

See Figure 3-5. Loosen the mounting plates bolts and move the table. Remove the mounting plates if necessary

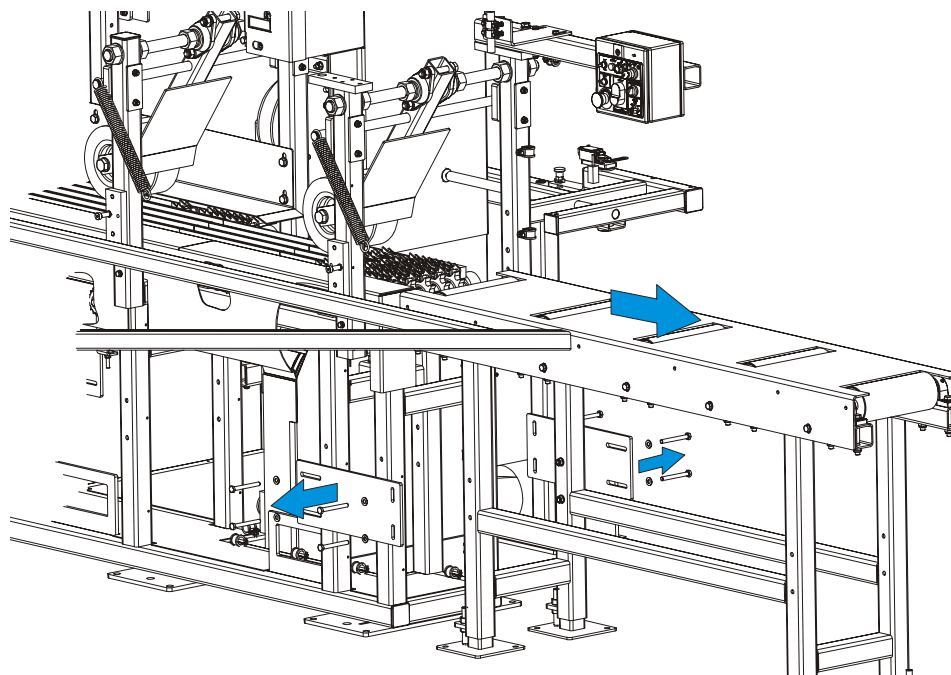

FIG. 3-5

See Figure 3-6. Chain tension adjustment bolts placement.

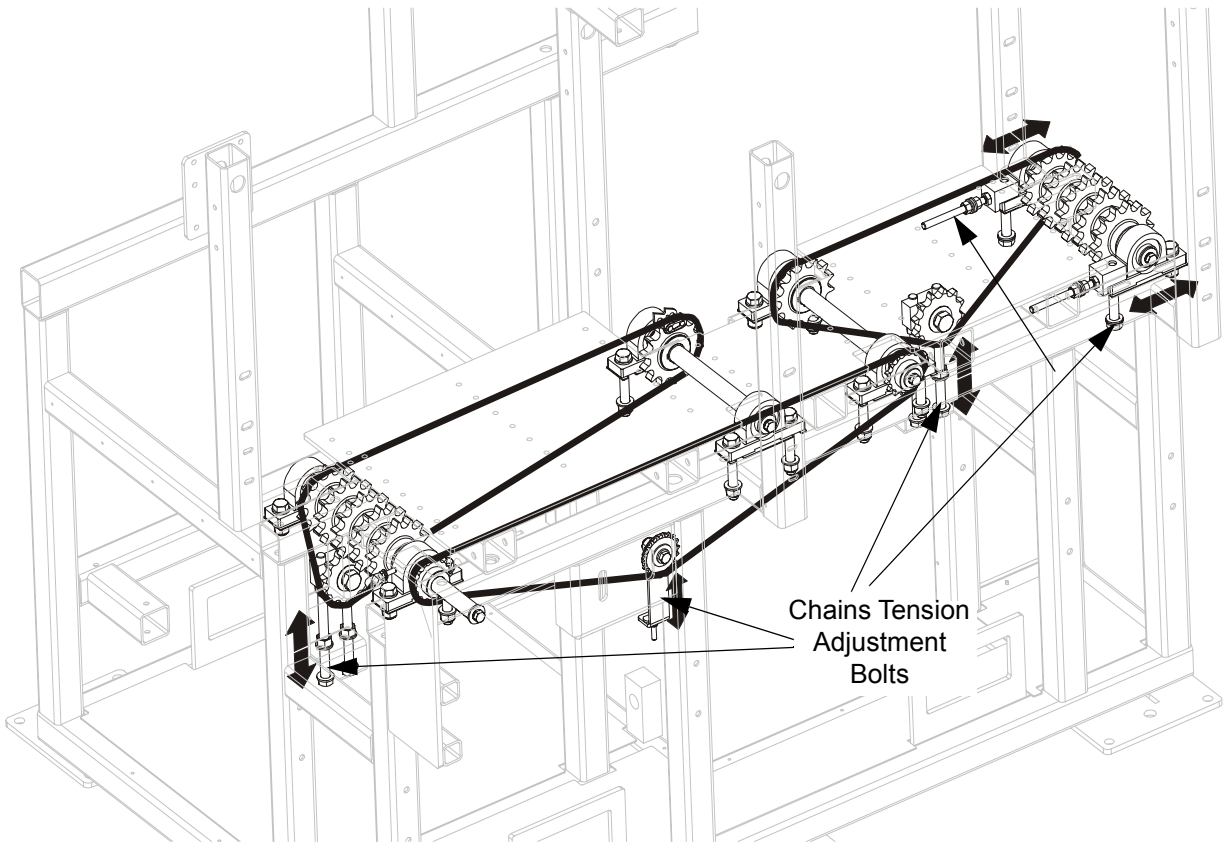

FIG. 3-6

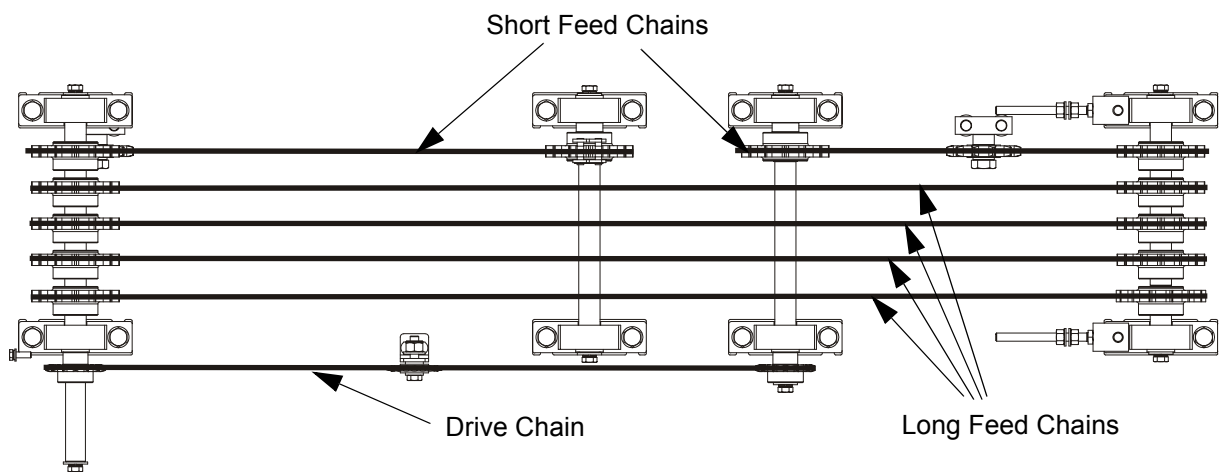

FIG. 3-7

2. First tension four long feed chains using appropriate adjustment bolts.

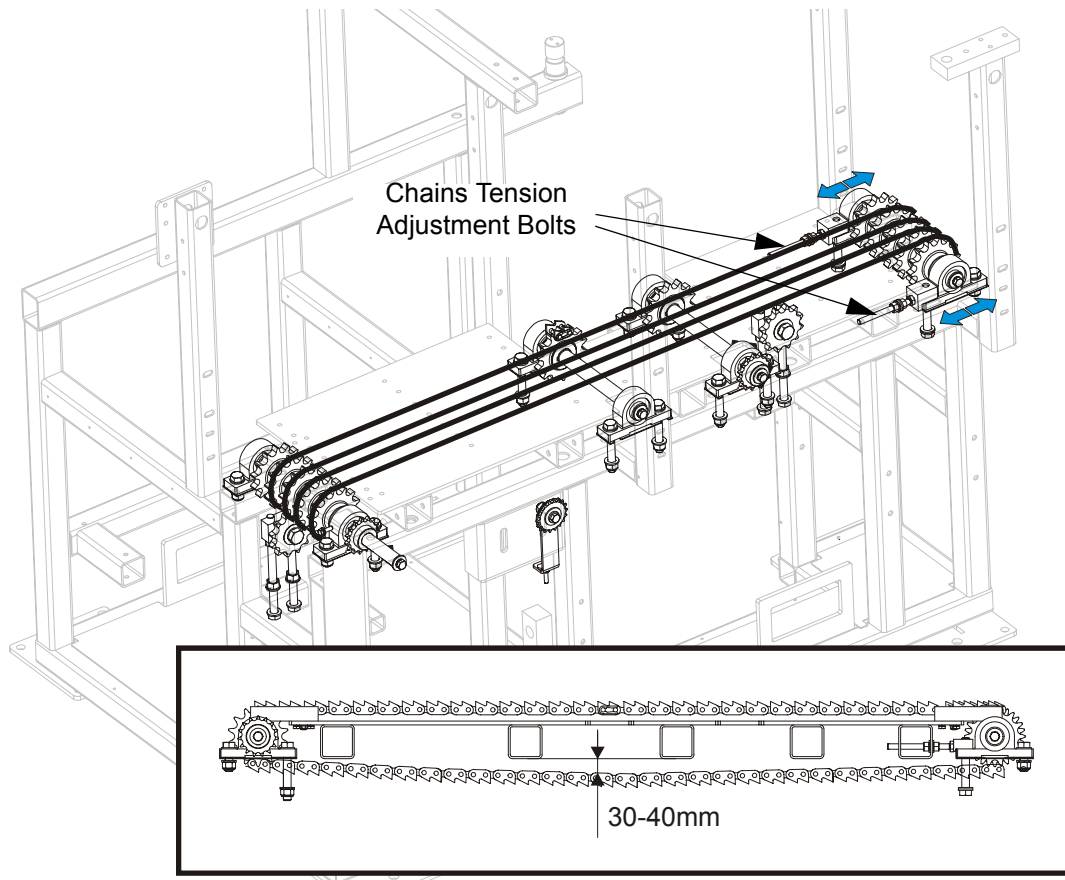

FIG. 3-8

3. Next tension two short feed chains using appropriate adjustment bolts.

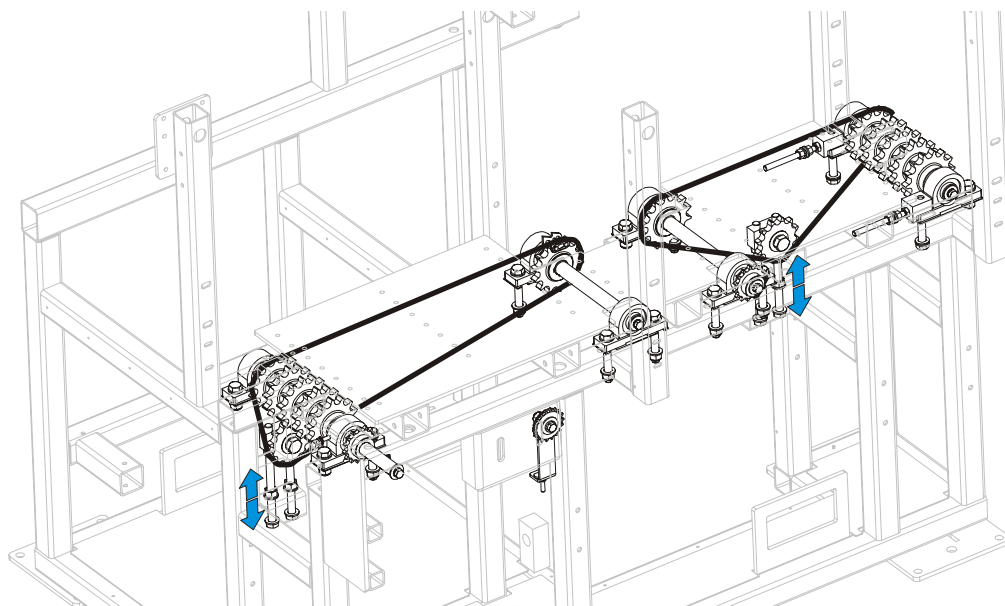

FIG. 3-9

4. Finally, tension the drive chain.

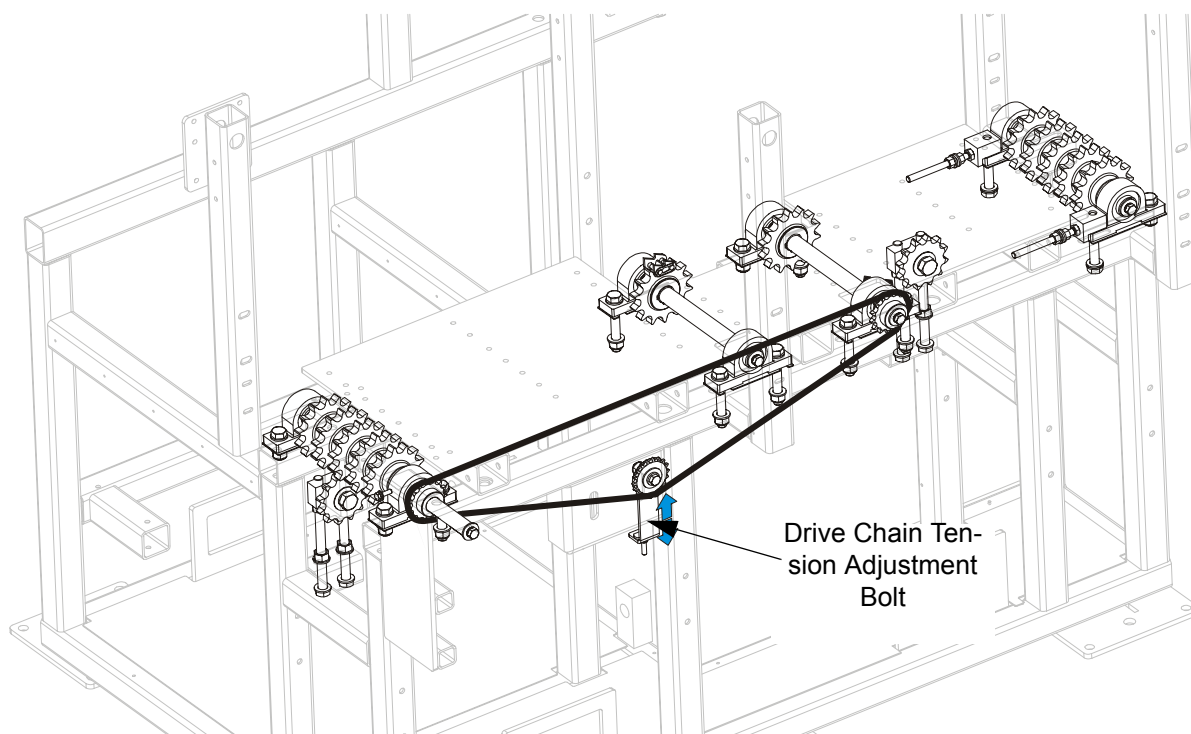

FIG. 3-10

5. If the chain or chains are worn, replace it with the new ones. To do this first dismount the

fence.

See **Figure 3-11**. Unscrew four bolt and remove the fence.

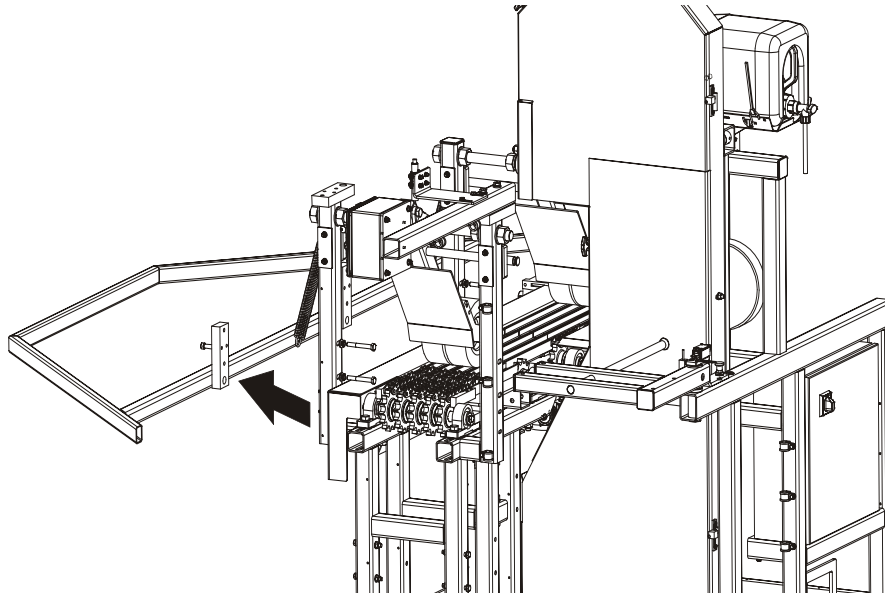

FIG. 3-11

6. Remove the chains drive cover.

See Figure 3-12.

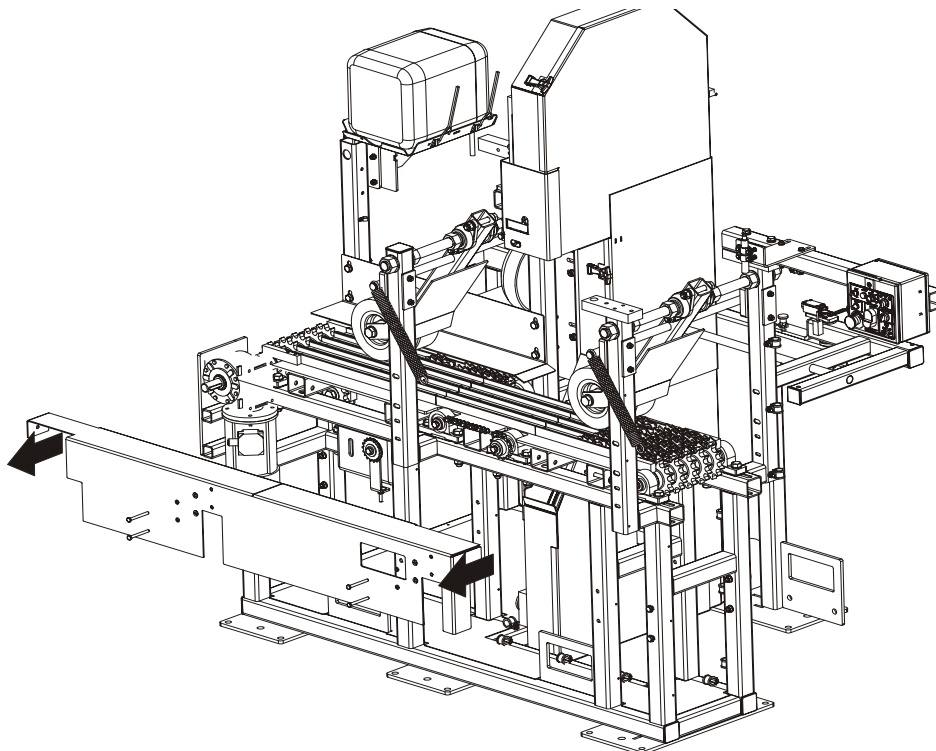

FIG. 3-12

7. Replace the worn chain or chains. Route the new chains as shown on Figure 3-7

3.9 Lube Mizer System

1. Clean the lube filter as needed.

To clean,

- Make sure the lube control is in the OFF position and the lube bottle valve is closed all the way.
- Unscrew the filter reservoir and flush with water.
- Remove the cylindrical mesh filter and gently flush with water.
- Replace the filter and reservoir.

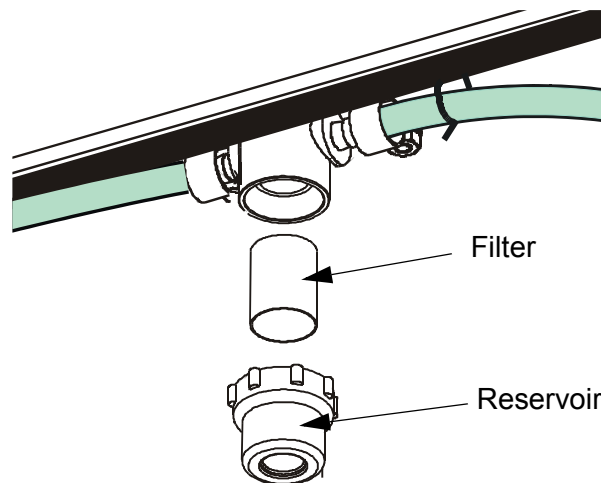

FIG. 3-12

2. Periodically check lube hoses and lines for buildup. Remove and flush with water as needed.
3. Periodically check the blade guide bracket nozzles for buildup. Remove and flush with water as needed.

SECTION 4 ALIGNMENT

The Wood-Mizer resaw is factory aligned. Be scrupulous when performing all alignment steps as resaw alignment determines the accuracy of your cuts. The alignment procedure should be performed approximately every 1500 hours of operation.

4.1 Alignment Procedure

4.1.1 Blade Installation And Tracking

See Figure 4-1. Install a blade and apply the proper tension as shown below. [See Section 2.4.](#)

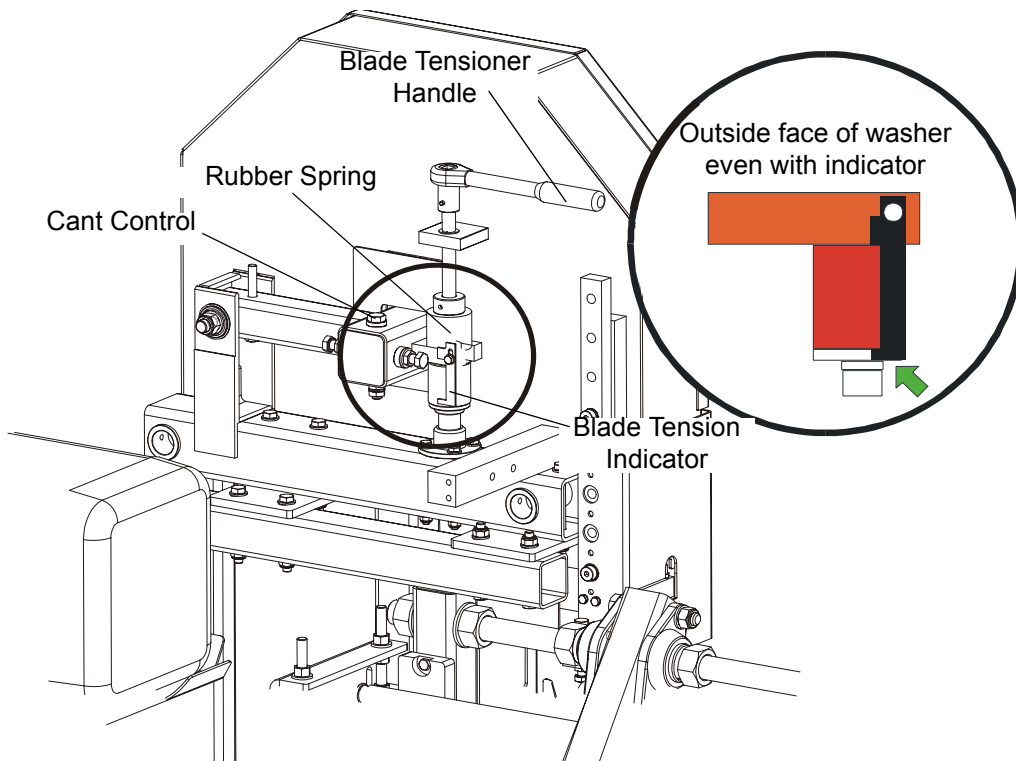

FIG. 4-1

1. Turn the key switch to the "H" position.



2. Open the blade housing covers.
3. Manually spin one of the blade wheels until the blade positions itself on the wheels.

See Figure 4-2. The blade wheels should be adjusted so that the gullet of 1 1/4" blades rides 3.0 mm (0.12") out from the front edge of the wheels (± 1.0 mm [0.04"]). The gullet of 1 1/2" blades should ride 4.5 mm (0.18") from the front edge of the wheels (± 1.0 mm [0.04"]). Do not let the teeth ride on the belt.

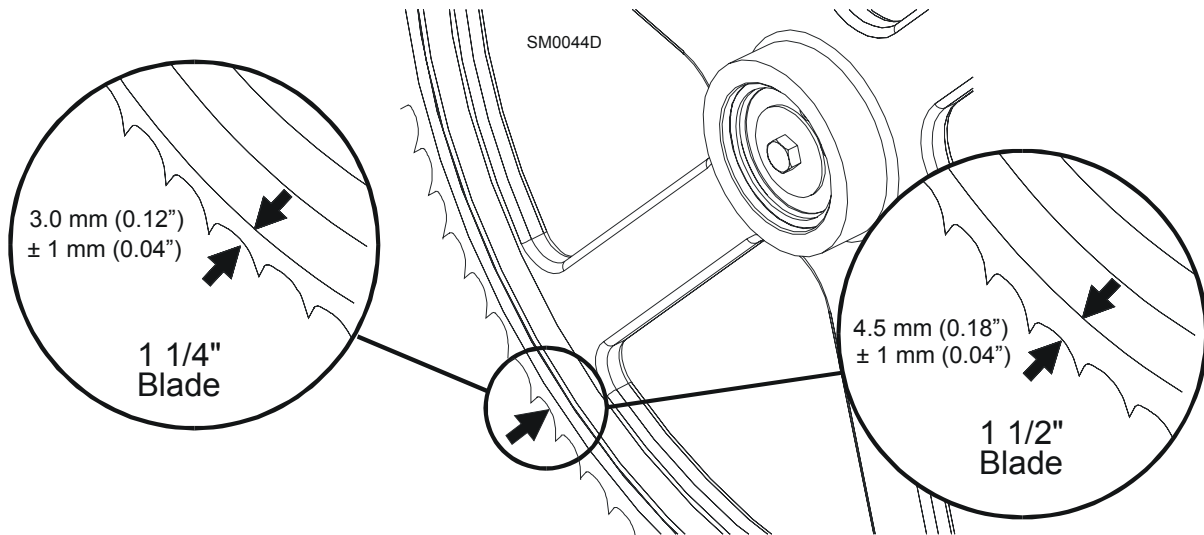

FIG. 4-2

To adjust where the blade travels on the idle-side blade wheel, use the cant control shown in **Figure 4-1**.

To move the blade out on the blade wheel, turn the cant adjustment bolt clockwise. To move the blade in on the blade wheel, turn the bolt counterclockwise.

Some adjustment in blade tension may be needed to compensate for adjustments made with the cant control.

Adjustment with the cant control is usually all that is required to track the blade properly on both blade wheels. The drive-side blade wheel will usually not have to be adjusted. If necessary, the drive-side wheel can be adjusted as follows:

Locate the adjusting bolt with lock nuts located on the drive-side of the cutting head. Turn the bolt clockwise to move the blade out on the wheel, turn it counterclockwise to move the blade in on the blade wheel. Make sure to tighten the lock nuts when adjustment is complete.

4

Alignment

Blade Wheel Alignment

4.1.2 Blade Wheel Alignment

The blade wheels should be adjusted so they are level in the vertical and horizontal planes. If the blade wheels are tilted vertically, the blade will want to move in the tilted direction. If the blade wheels are tilted horizontally, the blade will not track properly on the wheels. **The blade guide rollers should not touch and deflect the blade when adjusting the blade wheels.**

1. Use the blade guide alignment tool to check the vertical alignment of each blade wheel. Attach the tool to the blade near the lower blade guide mounts as shown. Be sure the tools do not rest on a tooth or burr, and are lying flat against the blades.

See Figure 4-3.

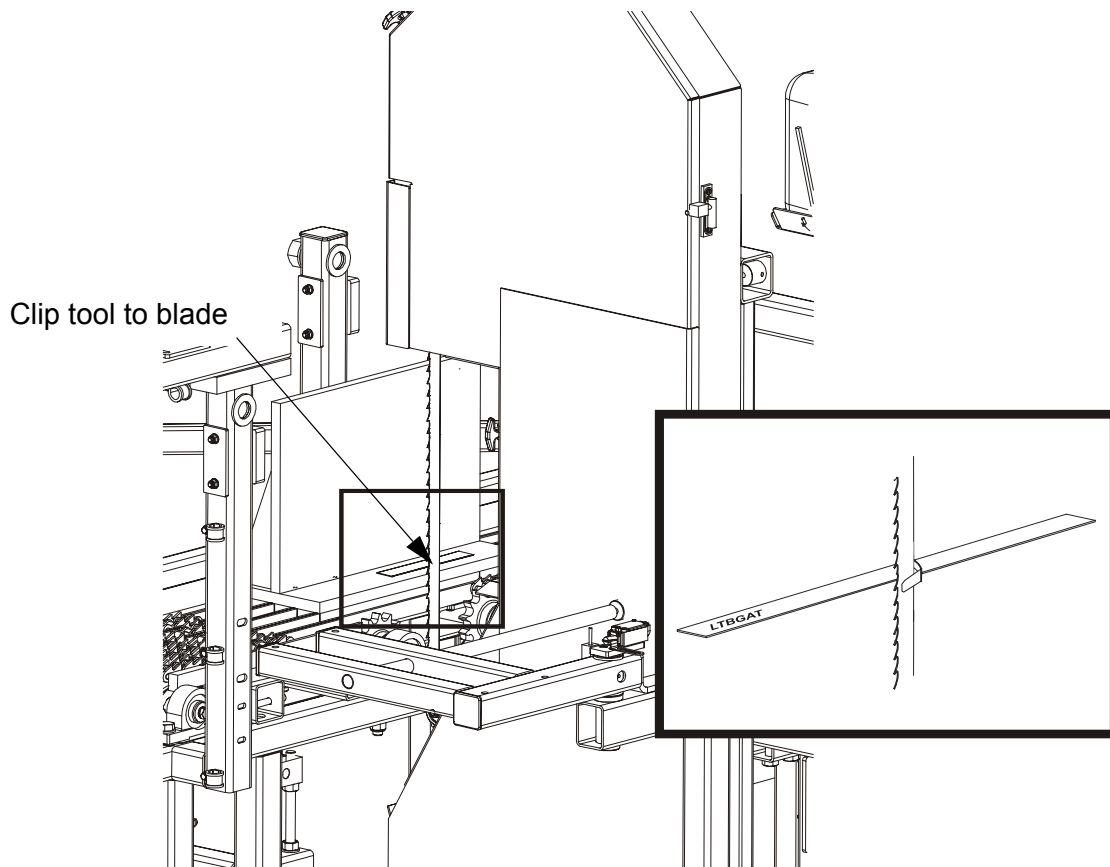

FIG. 4-3

2. Place the alignment plate on the feed chains teeth. The lower side bar should touch the teeth on its entire length.

See Figure 4-4.

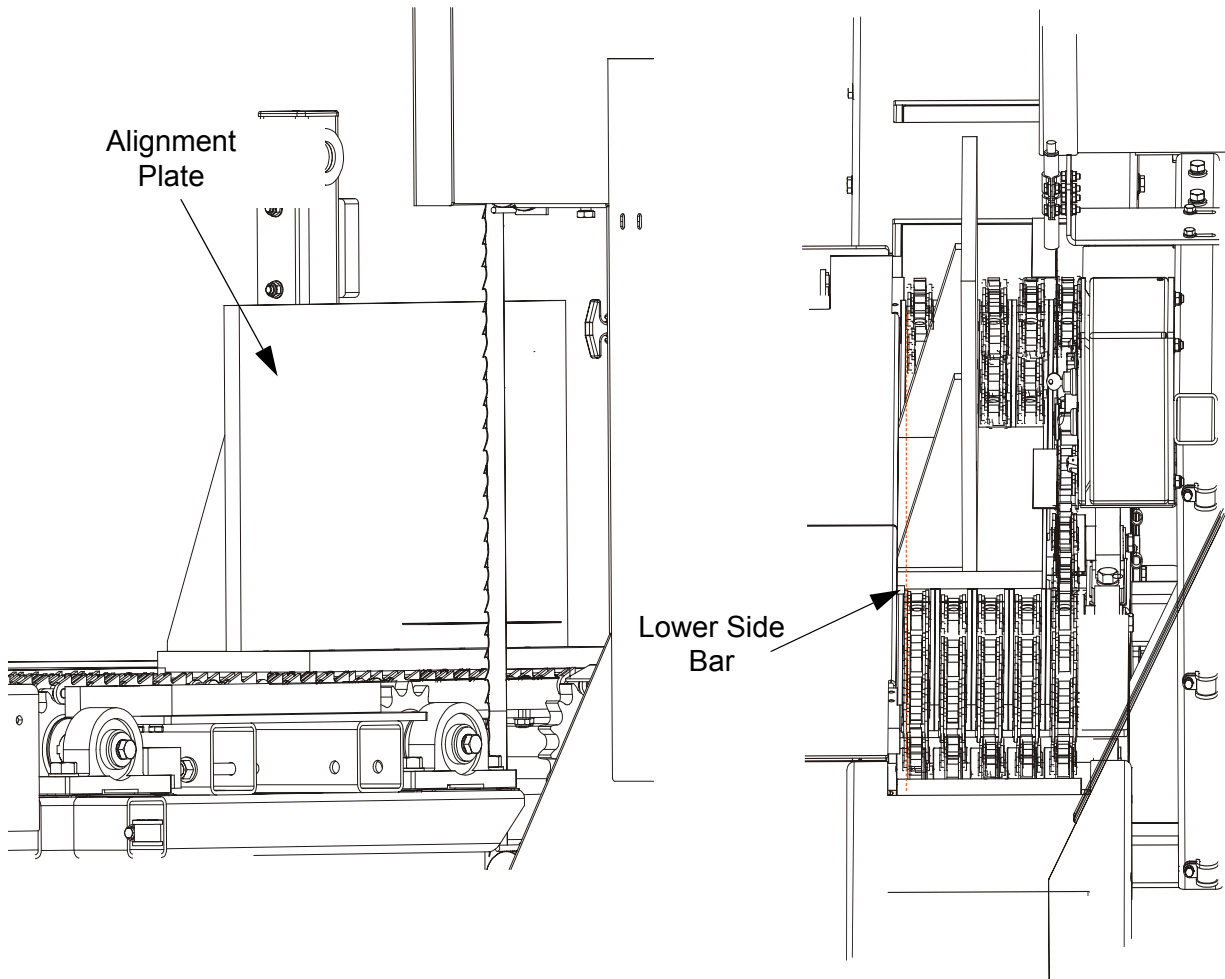

FIG. 4-4

3. Measure the distance from the edge of the tool clipped to the blade near the chains, to the plate surface. The distances marked A and B must be equal. If the measurements are different, use the drive side blade wheel adjustment bolts to correct its alignment.



IMPORTANT! Before adjusting the drive side wheel, loosen the drive belt. [See Section 4.7](#)

4 Alignment

Blade Wheel Alignment

See Figure 4-5.

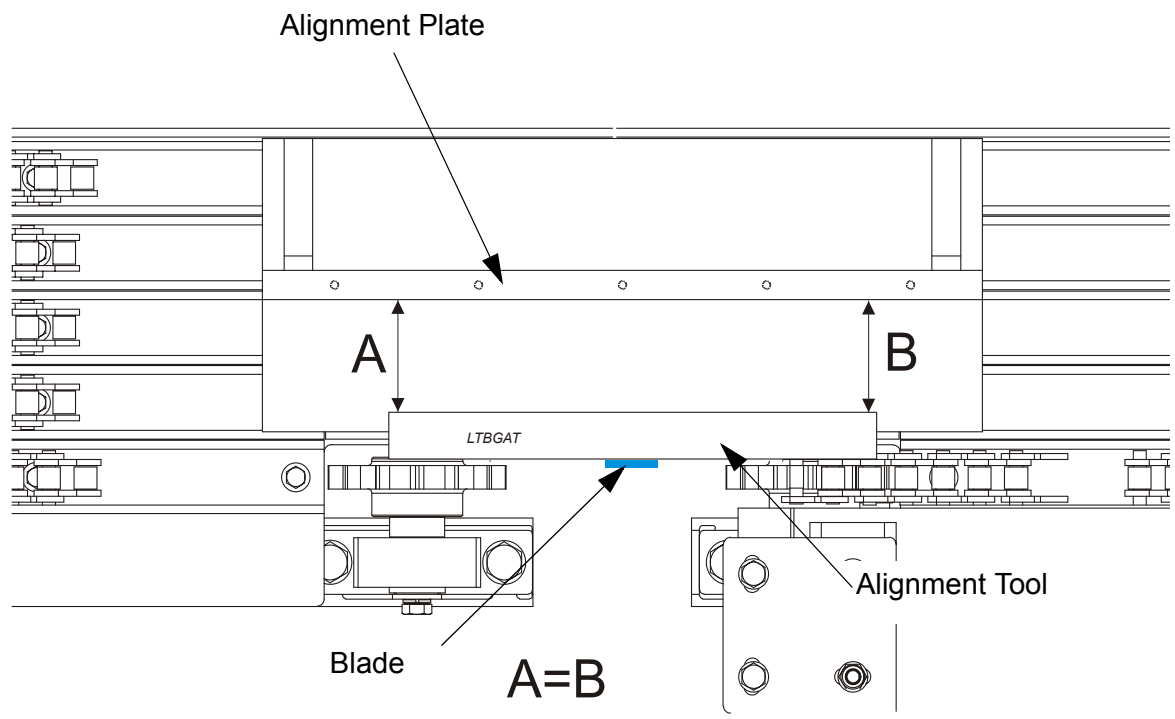

FIG. 4-5

See Figure 4-6. Loosen the lock nuts on the horizontal plane adjustment bolt. Next, use the vertical plane adjustment bolts to adjust the drive wheel so that the adjustment tool would be parallel to the alignment plate.

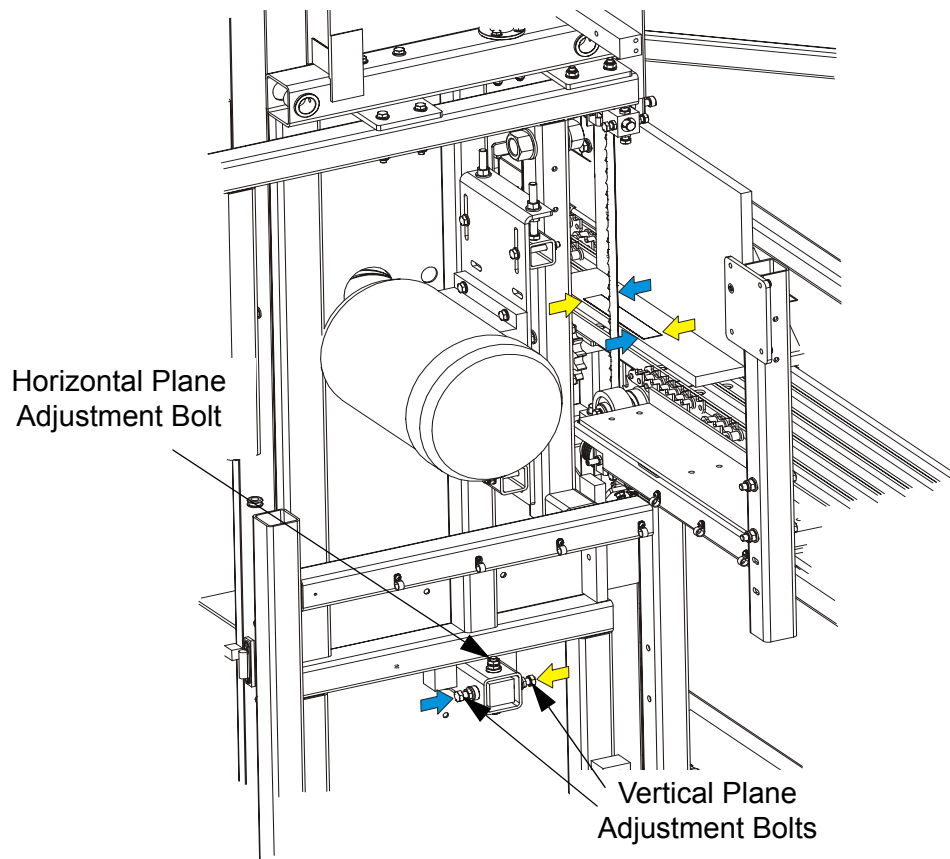

FIG. 4-6

4

Alignment

Blade Wheel Alignment

4. Attach the tool to the blade near the upper blade guide mount.

See Figure 4-7. Loosen the lock nuts on the horizontal plane adjustment bolt. Next, use the vertical plane adjustment bolts to adjust the idle wheel so that the adjustment tool would be parallel to the alignment plate.

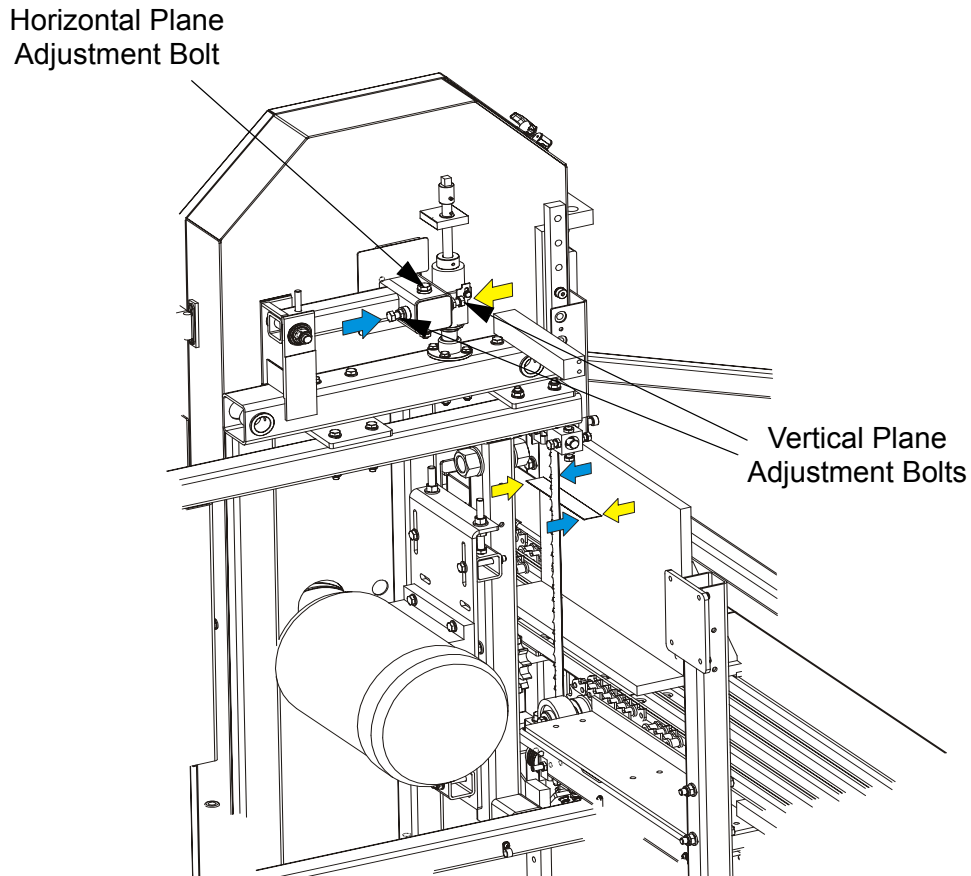

FIG. 4-7

5. Check the position of the blade on the idle-side blade wheel.

See Figure 4-8. The vertical tilt of the blade wheel should be adjusted so that the gullet of 1-1/4" blade is 3.0 mm out from the front edge of the wheel (± 1.0 mm).

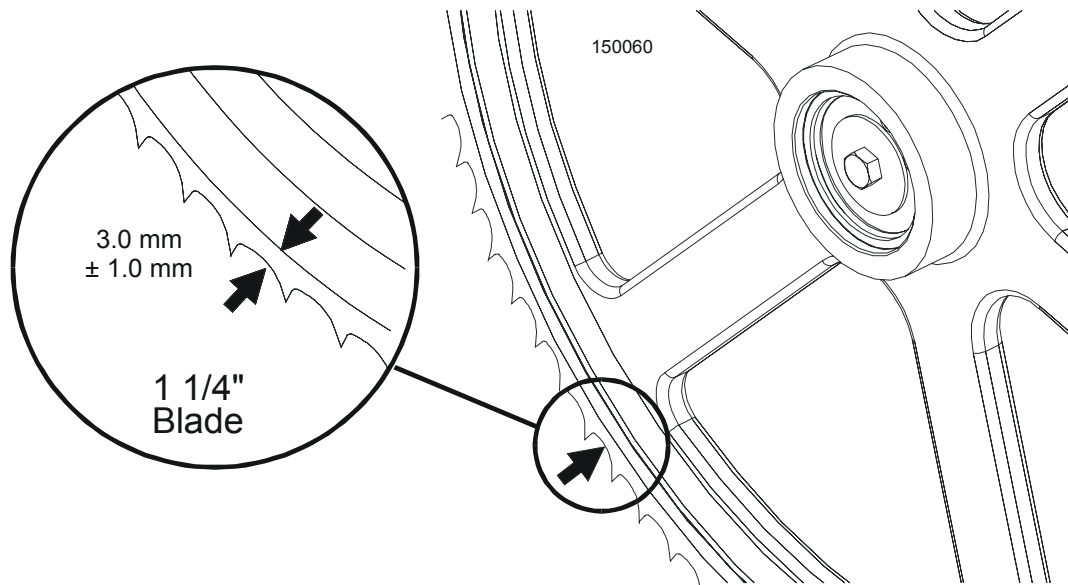

FIG. 4-8

See Figure 4-9. Use the cant control adjustment to adjust the idle-side blade wheel. If the blade is too far forward on the wheel, turn the cant control counterclockwise. If it is too far back on the wheel, turn the cant control clockwise.

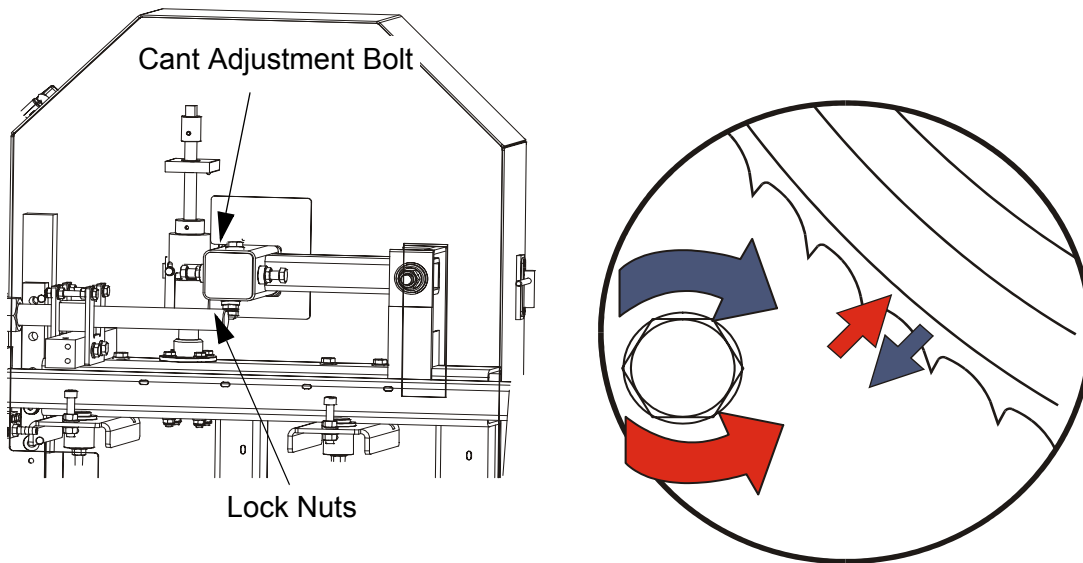

FIG. 4-9

6. Check the position of the blade on the drive-side blade wheel. The blade should be positioned on the wheel as described for the idle-side blade wheel. Adjust the drive-side blade wheel if necessary.

4

Alignment

Blade Wheel Alignment

See **Figure 4-10**. Use the cant control adjustment bolt to adjust the drive-side blade wheel. If the blade is too far forward on the wheel, turn the cant control bolt clockwise. If it is too far back on the wheel, turn it counterclockwise.

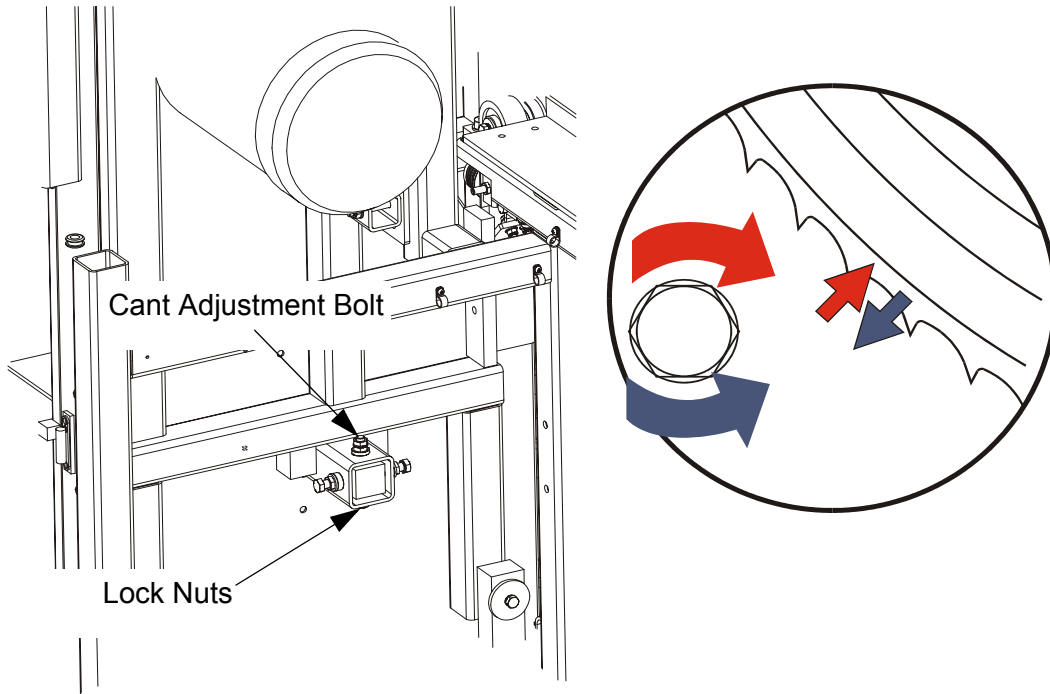

FIG. 4-10

4.1.3 Aligning the Blade Guides

Each Wood-Mizer resaw has two blade guide assemblies that help the blade maintain a straight cut. The two blade guide assemblies are positioned on the cutting head to guide the blade on each side of the material being cut.

One blade guide assembly is mounted in a stationary position on the drive side of the cutting head. This assembly is referred to as the "inner" blade guide assembly.

The other blade guide assembly is mounted on the idle side of the cutting head. It is referred to as the "outer" assembly and is adjustable for various widths of materials to be processed.

Blade guide alignment includes four steps:

- Blade Deflection,
- Blade Guide Vertical Tilt,
- Blade Guide Flange Spacing,
- Blade Guide Horizontal Tilt.

Perform the blade guide alignment after you have aligned the blade on the wheels.

NOTE: During blade guide alignment, remove the blade guide adjusting screws and apply a lubricating oil such as 10W30 or Dexron III to each screw. This will prevent the screws and threaded holes from corroding and make screw adjustments easier.

4.1.4 Blade Deflection

Perform the following steps to achieve proper blade deflection with the blade guides.

1. Set the blade guide arm fully close.
2. If the blade wheels adjustment has been performed correctly, measure the actual distance with a tape from the adjustment plate to the bottom of the blade.
3. Install the blade guides. Make sure the two set screws shown are threaded into the blade guide shaft until they touch each other.

4

Alignment

Blade Guide Horizontal Tilt Adjustment

See Figure 4-11.

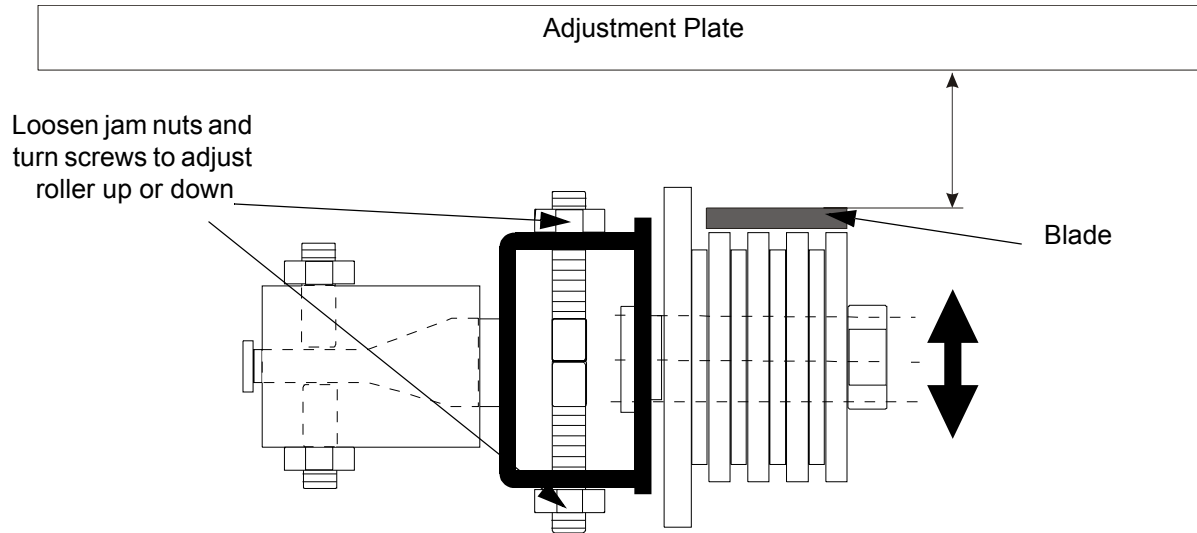

FIG. 4-11

4. Loosen the jam nut and tighten the appropriate screw until the blade guide deflects the blade 6.0 mm.
5. Repeat for the other blade guides.

NOTE: Be sure that the blade guide touches the blade in both guide assemblies.

4.1.5 Blade Guide Horizontal Tilt Adjustment

1. Attach the tools to the blade near the upper blade guides mount as shown. Be sure the tools do not rest on a tooth or burr, and are lying flat against the blades.

See Figure 4-12.

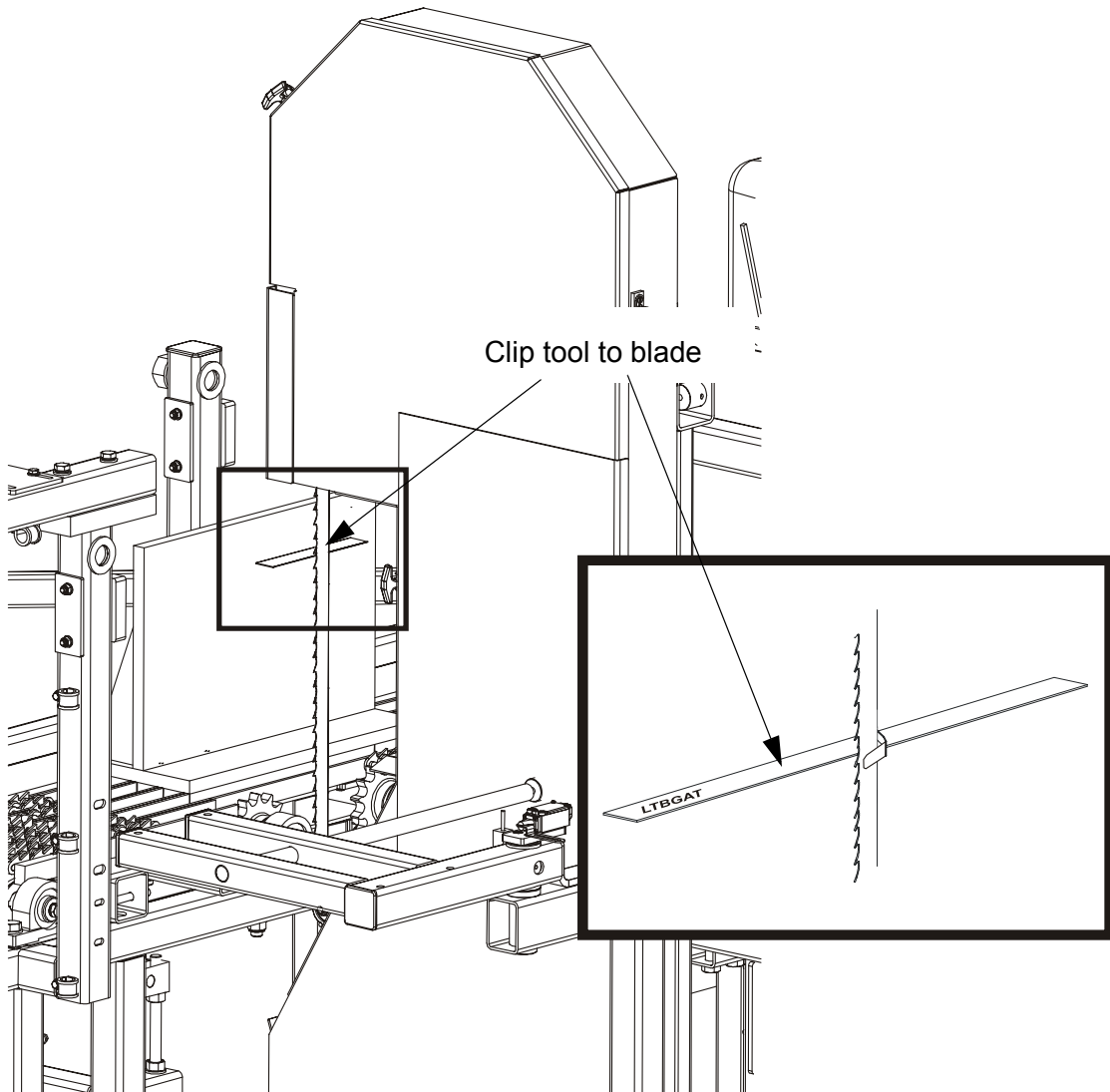

FIG. 4-12

Check that the blade guide does not tilt the blade left or right. A Blade Guide Alignment Tool (LTBGAT) is provided to help you measure the vertical tilt of the blade.

2. Position the tools near the upper blade guide.
3. Measure the distance from the edge of the tool to the adjustment plate at the back end of the tool and then at the front end of the tool.

4

Alignment

See Figure 4-13.

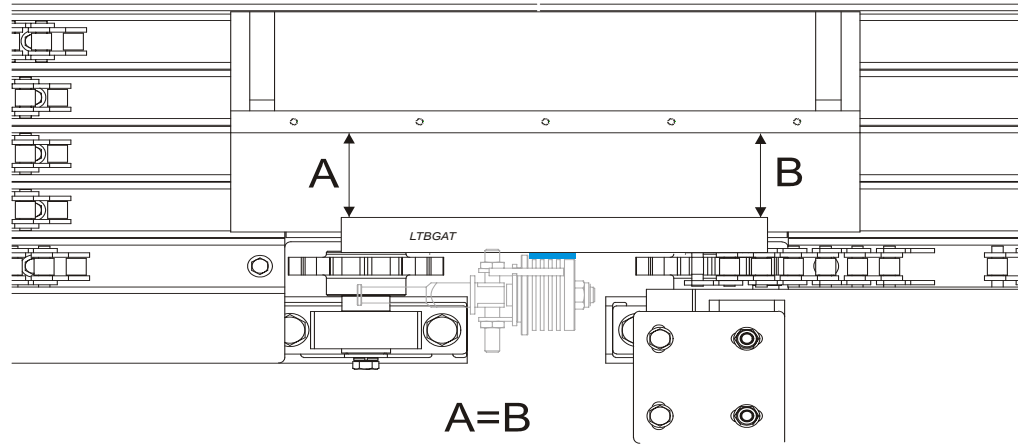

FIG. 4-13

4. The two distances should be equal. If the distances A and B differ, adjust the horizontal tilt of the blade guide using the adjustment screws shown in the figure below.

See Figure 4-14. Loosen the jam nuts on the left and right horizontal tilt adjustment screws. To tilt the roller left, loosen the right screw and tighten the left screw. To tilt the roller right, loosen the left screw and tighten the right screw. Tighten the jam nuts and recheck the tilt of the blade.

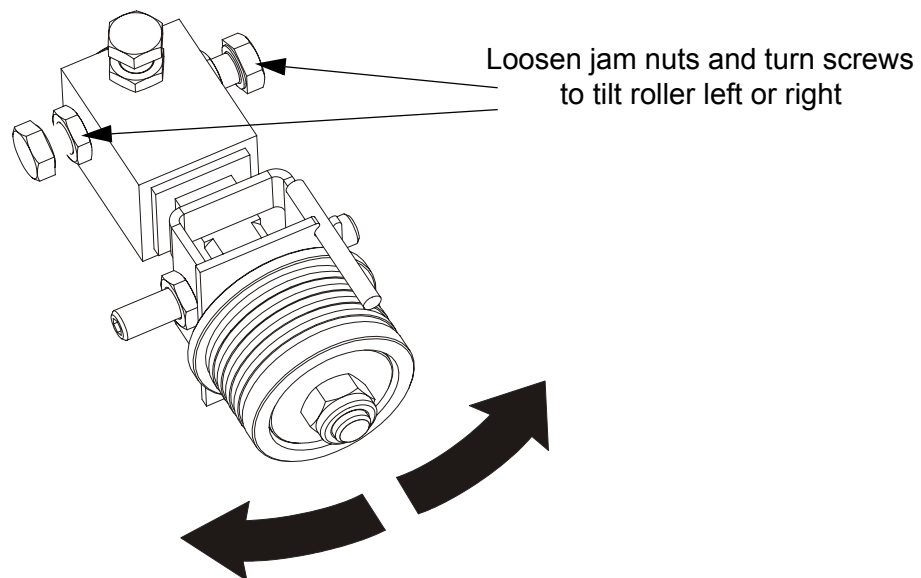

FIG. 4-14

5. Attach the tool to the blade near the lower blade guide mount blocks and repeat above

steps. Adjust the horizontal tilt of this guide if necessary.

NOTE: Be sure that the A and A' distances and B and B' distances are equal. See the figure below. The blade deflection of both blade guides can not be lower than 6mm.

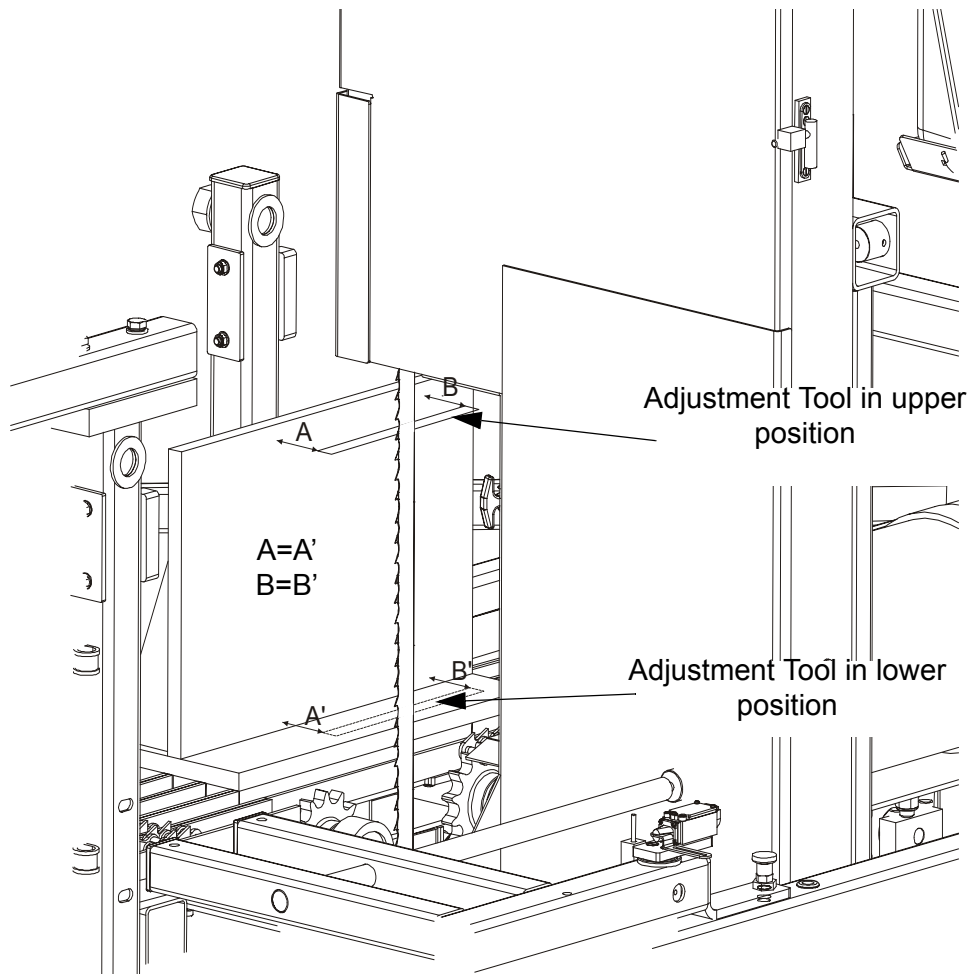

FIG. 4-14

NOTE: If major adjustments to blade guide tilt were made, measure the actual distance with a tape from the adjustment plate to the bottom of the blade again to ensure the correct 6.0 mm (0.24") blade guide deflection. Adjust if necessary.

4.1.6 Blade Guide Spacing

4

Alignment

Blade Guide Vertically Tilt Adjustment

HINT: When adjusting blade guide spacing, loosen the top set screw and one side set screw only. This will ensure horizontal and vertical tilt adjustments are maintained when the set screws are retightened.

1. Adjust the lower blade guide so the blade guide flange is approximately 1.5 – 3.0 mm (0.06 - 0.12") from the back of the blade.
2. Loosen one side and one top set screw shown. Tap the blade guide forward or backward until properly positioned.

See Figure 4-15.

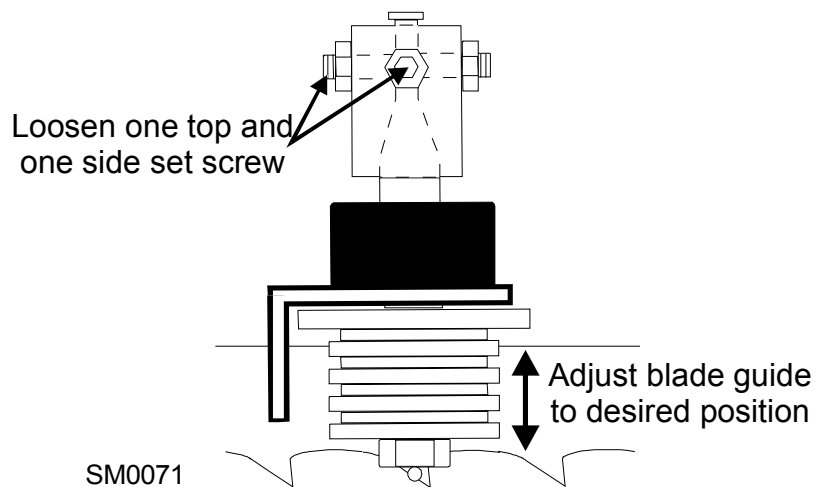

FIG. 4-15

3. Retighten the two set screws.
4. Adjust upper blade guide in the same way so the blade guide flange is approximately 1.5 – 3.0 mm (0.06 - 0.12") from the back of the blade.

4.1.7 Blade Guide Vertically Tilt Adjustment

1. Finally, both blade guides must be tilted vertically. Adjust the blade guide arm halfway in.

See Figure 4-16.

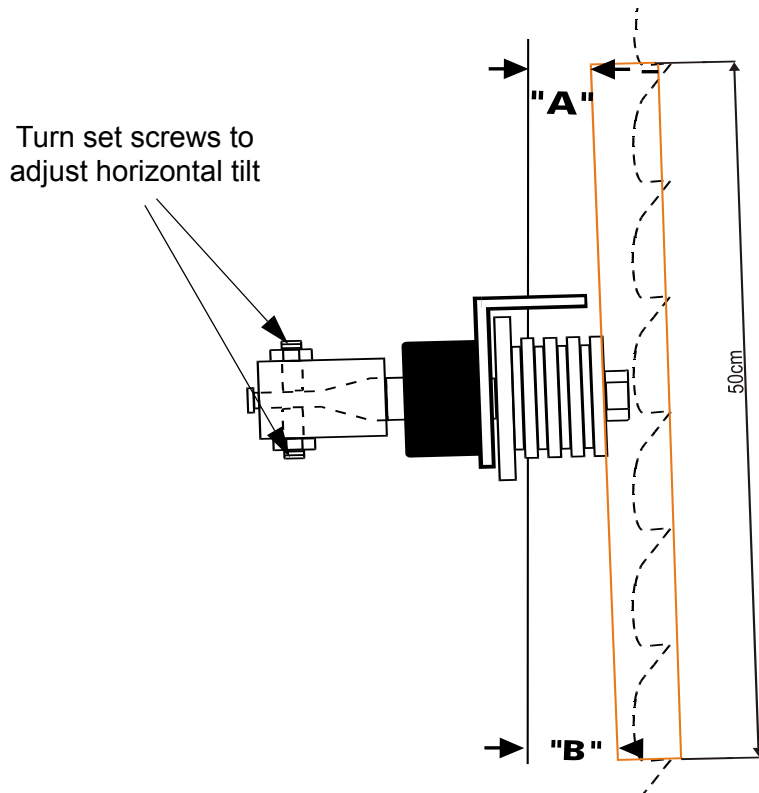

FIG. 4-16

2. Place the Blade Guide Alignment Tool against the face of the upper blade guide roller.
3. Center the tool on the roller and measure the distance between the back edge of the blade and the ruler at the end closest to the lower blade guide ("B").
4. Measure between the back edge of the blade and the other end of the ruler ("A").
5. The roller should be tilted slightly up ($A = B - 6.0 \text{ mm [0.24"]}$).
6. Use the set screws to adjust the horizontal tilt of the roller.
7. Repeat steps 3-7 for the lower blade guide roller.

NOTE: Once the blade guides have been adjusted, any cutting variances are most likely caused by the blade. See the **Wood-Mizer® Blade Handbook, Form #600**.

SECTION 5 SPECIFICATIONS

5.1 Overall Dimensions

See **Figure 5-1**. The major dimensions of the Single Vertical Saw are shown below (all dimensions are in millimeters).

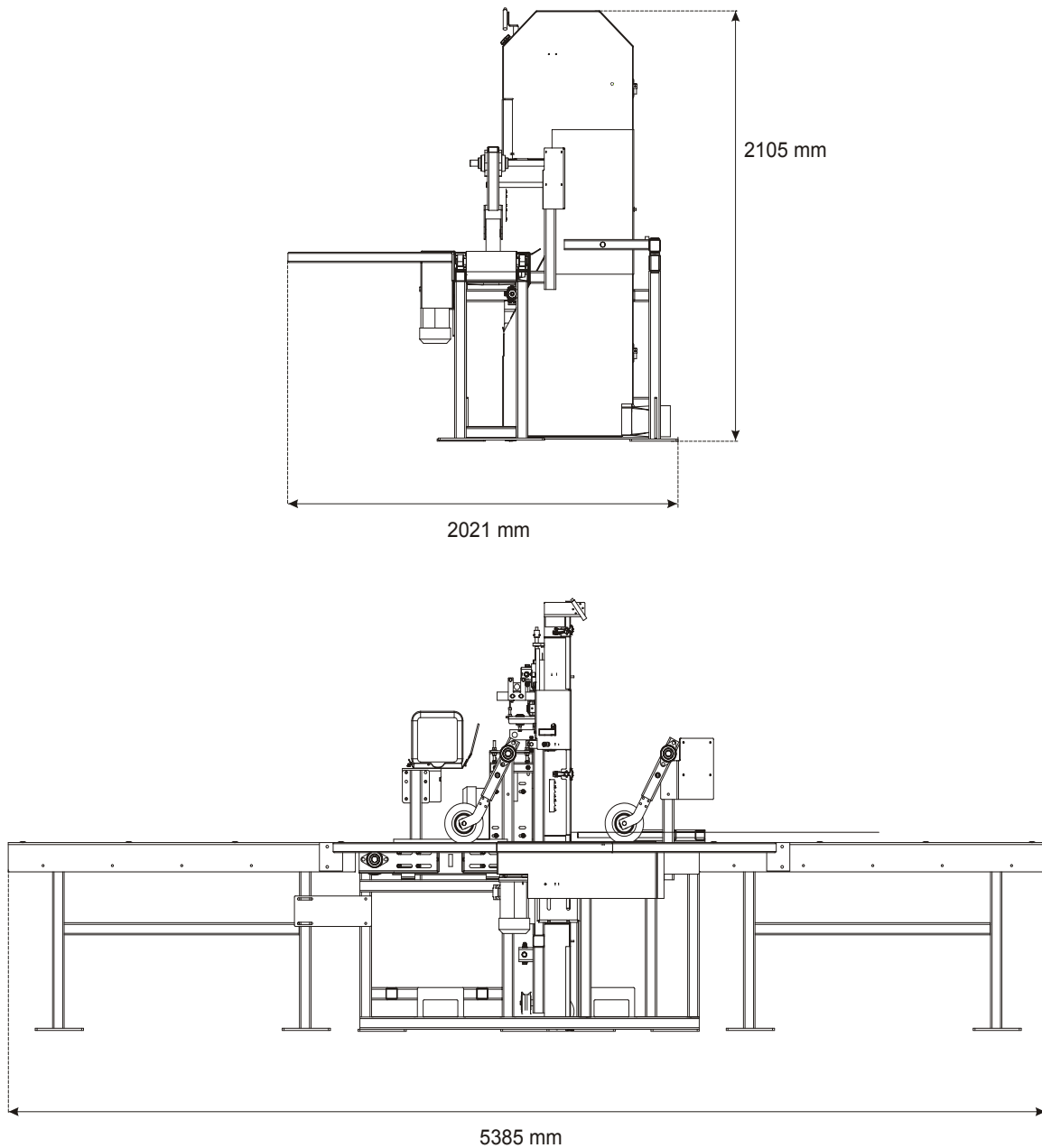

FIG. 5-1

See Figure 5-2. The figure shows the locations of resaws legs.

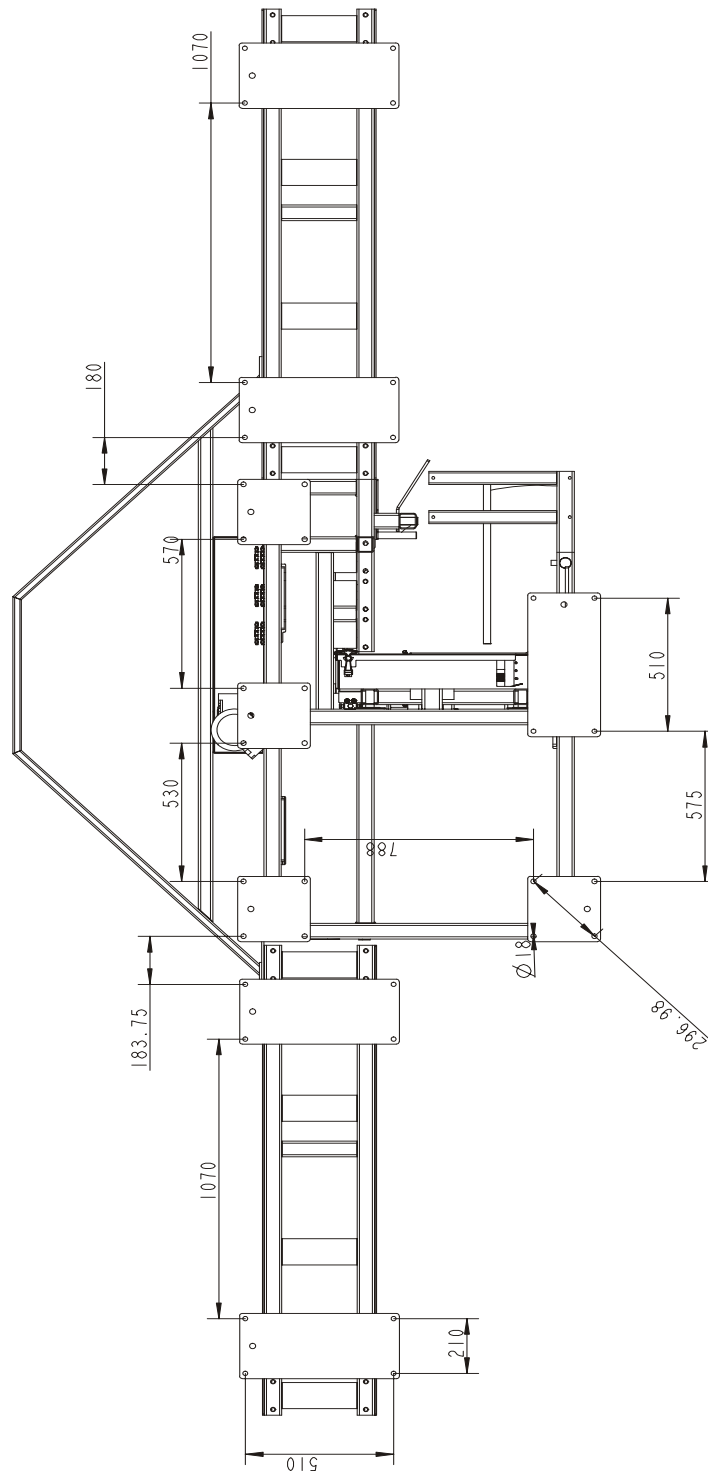

FIG. 5-2

5 Specifications

Cutting Capacity

See Table 5-1. The overall dimensions of the SVS are listed in the table below.

Weight	1100 kg
Height	2105 mm
Width	2021 mm
Length	5385 mm

TABLE 5-1

5.2 Cutting Capacity

See Table 5-2. The material size and performance capacities of the SVS are given below.

Cutting Length	1 - 3,6 m
Max Material Width	400 mm
Max Material Height	250 mm
Feed Speed	0-25 m/min

TABLE 5-2

See Table 5-3. Wood-Mizer TRU•SHARP™ offers three types of blades to provide efficient sawing. The type of wood you saw should determine which blade you choose for optimum performance.

Motor Size	Recommended Blade Type		
	Softwood	Medium Hardwood	Frozen Timber or Dense Hardwood
5 HP - 15 HP	.042 x 7/8 x 1 1/4"	.042 x 7/8 x 1 1/4 "	.045 x 7/8 x 1 1/4" F1

5.3 Blade Motor Specifications

See Table 5-4. See the table below for motor specifications for SVS.

Motor Type	Manufacturer	Model	Power	Other Specifications
Blade Motor	Indukta, Poland	SG132S -2PC HM	11kW	400 V/50Hz; 20,3 Amp; 2920 r.p.m.
Feed Track Motor	Besel, Poland	SKh80X-4C1 IMB14/1-162	1,1kW	400 V/50Hz; 2,3 Amp; 1380 r.p.m.

TABLE 5-4

See Table 5-5. The noise levels of the Wood-Mizer SVS are listed below¹².

	Noise Level L _{EX8}
E15 Electric Motor	92,3 dB (A)

TABLE 5-5

-
1. The noise level measurement was taken in accordance with PN-EN ISO 3746 Standard . The noise exposure level given above concerns an 8-hour work day.
 2. The measured values refer to emission levels, not necessarily to noise levels in the workplace. Although there is a relation between emission levels and exposure levels, it is not possible to determine with certainty if preventives are needed or are not needed. The factors affecting a current level of noise exposure during work are inter alia room characteristics and characteristics of other noise sources, e.g. number of machines and machining operations nearby. Also, the permissible exposure level value may vary depending on country. This information enables the machine's user to better identify hazards and a risk .

5.4 Electrical Diagram

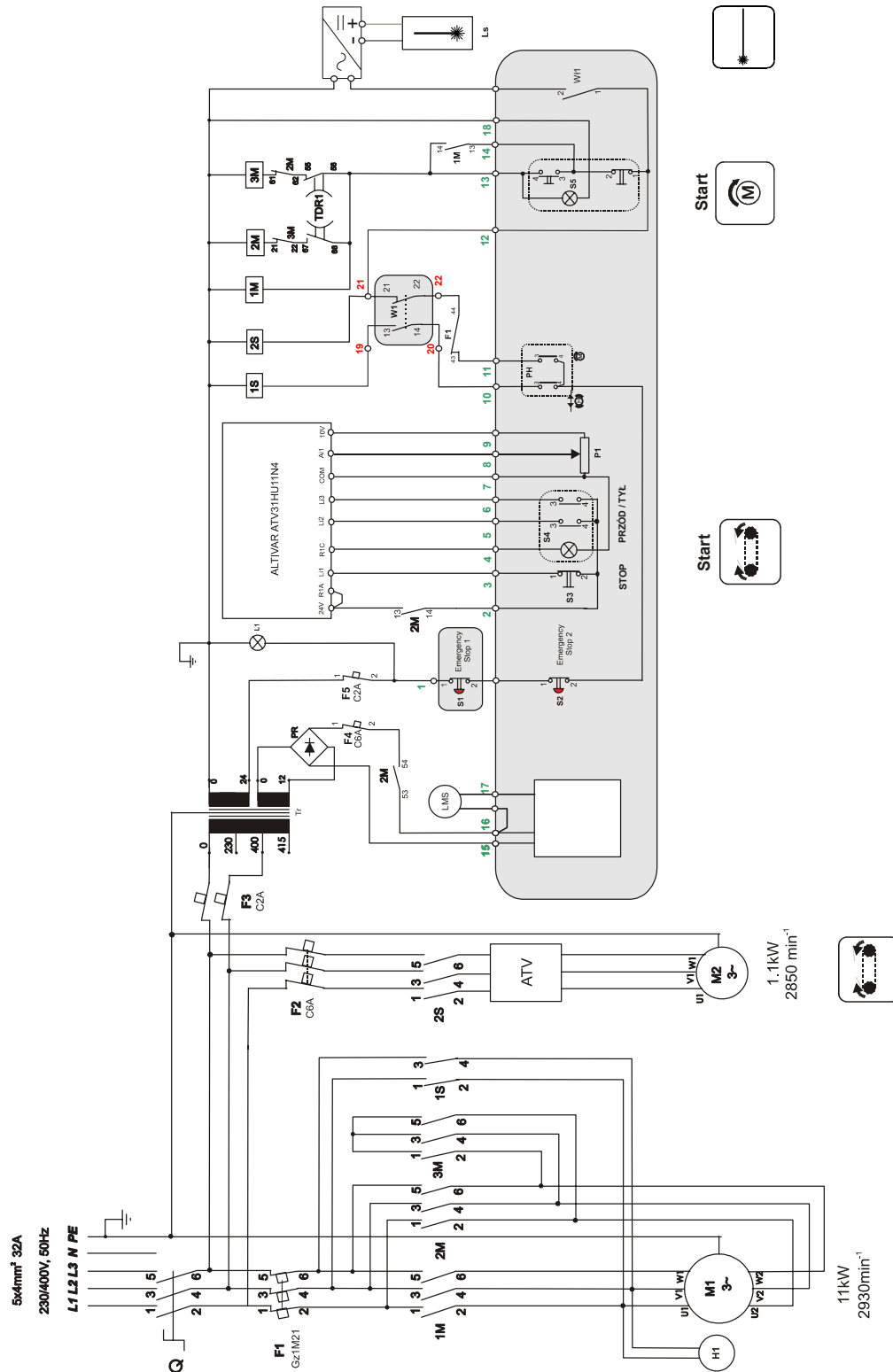

FIG. 5-2

5.5 Electrical Component List, SVS

Symbol	Wood-Mizer Part No.	Description	Manufacturer
Q	095473	Switch ABB OT45 E3	ABB
F1	084330	Motor Circuit Breaker Gz1 M21	SCHNEIDER ELECTRIC
1M, 2M	084306	Contactora LC1 D18 B7	SCHNEIDER ELECTRIC
2S, 3M	084305	Contactora LC1 D09B7	SCHNEIDER ELECTRIC
1S	084308	Contactora LC1 D0610B7	SCHNEIDER ELECTRIC
F2		Circuit Braker C60N 3P C6	SCHNEIDER ELECTRIC
F3		Circuit Braker C60N 2P C2	SCHNEIDER ELECTRIC
F4		Circuit Braker C60N 1P C6 24399	SCHNEIDER ELECTRIC
F5		Circuit Braker C60N 1P C2 24396	SCHNEIDER ELECTRIC
TR		Transformator TMM160/A 230/400/415/12/24	BREVE
TDR1	084037	Time Relay LAD S2	SCHNEIDER ELECTRIC
L1	090448	Control Lamp, White M22 LED24V	MOELLER
ATV	096488	Speed Controller ATV31HU11N4	SCHNEIDER ELECTRIC
M1	089049	Saw Head Motor SG132S -2PC HM	INDUKTA
H1		Motor Brake H132	EMA-ELFA
W1	088407	SWITCH, GSCA 01S1 LIMIT GSCA 01S1	HONEYWELL
S1	E22703-P	Emergency Switch XALK 174	SCHNEIDER ELECTRIC
S2	086556	SWITCH EMERGENCY XB2 BS542	SCHNEIDER ELECTRIC
S3	091364	Switch M22	MOELLER
S4	091359	Switch M22 WRLK3-G	MOELLER
S5	090452	START-STOP Button M22 DDL-GR-X1/X0/K11/230-W	MOELLER
PH	091361	Key Switch M22-WRS3	MOELLER
M2	090104	Motor SKh80X-4C1 IMB14/1-162	BESEL

5.6 Dust Extractor Specifications

See Table 5-6. Specifications of the dust extractors used on the SVS are listed below.

Airflow	2400 m ³ /h
Inlet diameter	150 mm
Motor power	2x1,5 kW
Number of sacks	2 pcs
Sack capacity	0.25 m ³
Weight	110 kg
Recommended conveying air velocity in the duct	20 m/s

TABLE 5-6



IMPORTANT! The dust extractor hoses must be grounded or made with materials not accumulating electrostatic charge.

SECTION 6 DC ELECTROMAGNETIC BRAKE

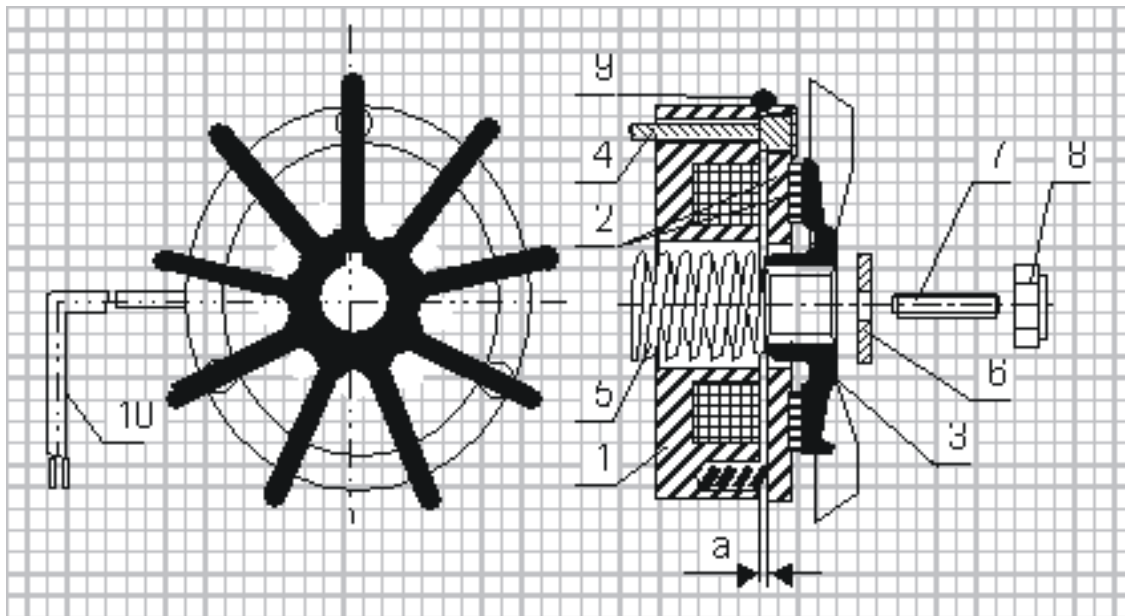

- 1 - Electromagnet,
- 2 - Armature complete with brake linings,
- 3 - Fan,
- 4 - Retaining bolt
- 5 - Central spring,
- 6 - Special washer,
- 7 - Set screw,
- 8 - Self-locking nut,
- 9 - Sealing ring,
- 10 - Output cable.

6.1 Design and principle of operation

The DC electromagnetic brake type H consists of 3 main subassemblies:

- electromagnet (1),
- armature complete (2)
- cast iron fan (3).

Electromagnet (1) energised: The DC voltage from the motor applied via the rectifying circuit causes the attraction of the armature (2) releasing the brake and thus the fan (3) is free to rotate.

Electromagnet (1) de-energised: The electromagnet stops to attract the armature (2) and spring presses the armature with brake linings (2) against the fan and the brake is thus applied.

6.2 Service

During normal operation and at the routine inspections verify the air gap and check if all screws are tight. In case when any symptoms of inefficient braking are observed, then use the self-locking nut (8) to re-adjust the air gap to the value corresponding to Table 1.

Such readjustment may be repeated until the brake linings are completely worn out. When this will occur, a complete armature with brake linings (2) must be replaced.

If the air gap of the brake is correctly adjusted and despite of it the brake does not operate properly (the brake fails to release), it may be caused by:

- the electromagnet (1): burned coil or defected output cable (10),
- rectifying circuit (installed in the electric motor terminal box).

The above mentioned subassemblies should be checked and defected part replaced.

Table 1:

TYPE	H-63	H-71	H-80	H-90	H-100	H-112	H-132	H-160
Nominal Gap „a”	0.2 ±0,05	0.2 ±0,05	0.2 ±0,05	0.2 ±0,05	0.2 ±0,1	0.2 ±0,1	0.2 ±0,1	0.2 ±0,1