



user manual

Instrukcja obsługi | Руководство пользователя
Manuel de l'Utilisateur | Betriebsanweisung
Bruksanvisning | Manual del Usuario
Betjeningsvejledning | Gebruikershandleiding
Käyttöohjeet | Manual de utilizare | Bruksanvisning
Manuale d'uso | Příručka uživatele

Retain for future use
Zachować do przyszłego użytku
Сохраните для последующего
использования
A conserver pour une utilisation future
Für zukünftige Benutzung aufbewahren
Behold for senere bruk
Säilytä nämä käyttöohjeet tulevaa tarvetta marten
Opbevar manualen til fremtidig brug
Bewaren voor gebruik in de toekomst
Conservare il presente manuale a l'uso futuro
Păstrați acest manual pentru utilizare viitoare
Conservar para futuras consultas
Behall för framtida användning
Uchovejte pro další použití
Hranite za prihodnjo uporabo

Horizontal Resaw HR700

Safety, Operation, Maintenance

HR700E15S -1/6	rev. A1.02
HR700E20S -1/6	rev. A1.02
HR700E25S -1/6	rev. A1.02



Safety is our #1 concern! Read and understand all safety information and instructions before operating, setting up or maintaining this machine.

April 2014

Form #1007

**This is the original language
for the manual.**

Table of Contents

Section-Page

General Contact Information
Branches & Authorized Sales Centers Wood-Mizer Locations (North and South America)

SECTION 1	SAFETY	1-1
1.1	Safety Symbols.....	1-1
1.2	Safety Instructions.....	1-2
	<i>Observe Safety Instructions</i>	
	<i>Wear Safety Clothing</i>	
	<i>Keep Resaw And Area Around Resaw Clean</i>	
	<i>Dispose Of Sawing By-Products Properly</i>	
	<i>Check Resaw Before Operation</i>	
	<i>Keep Persons Away</i>	
	<i>Keep Hands Away</i>	
	<i>Use Proper Maintenance Procedures</i>	
	<i>Keep Safety Labels In Good Condition</i>	
SECTION 2	OPERATION	2-1
2.1	Control Overview.....	2-1
2.2	Resaw Setup.....	2-3
	<i>Electrical Requirements (US Version Only)</i>	
2.3	Replacing The Blade.....	2-14
2.4	Tensioning The Blade.....	2-16
2.5	Tracking The Blade.....	2-17
2.6	Saw Head Height Adjustment.....	2-18
2.7	Guide Fence Adjustment.....	2-21
2.8	Blade Guide Arm Adjustment.....	2-22
2.9	Machine Start.....	2-23
2.10	Water Lube Operation.....	2-26
	<i>Standard Lube System (Supplied from a Water Supply Network)</i>	
	<i>Optional Lube System (Supplied from Water Tanks)</i>	
2.11	Operation Procedure.....	2-29
SECTION 3	MULTISETWORKS OPERATION (OPTIONAL EQUIPMENT)	3-1
3.1	General Information.....	3-1
3.2	Functions.....	3-1
3.3	Start-up.....	3-2
	<i>Calibration</i>	
3.4	Manual Mode.....	3-4
3.5	X-Board Mode.....	3-7

Table of Contents

Section-Page

3.6	Diagnostic.....	3-10
	<i>Calibration</i>	
	<i>Diagnostic I/O</i>	
	<i>Tuning</i>	
3.7	Errors.....	3-18
	<i>Impulses are not counted.</i>	
	<i>Incorrect up/down movement direction</i>	
	<i>Limit switches</i>	
	<i>Positioning error</i>	
SECTION 4 MAINTENANCE		4-1
4.1	Wear Life.....	4-1
4.2	Blade Guides	4-2
4.3	Sawdust Removal.....	4-2
4.4	Vertical Mast	4-2
4.5	Miscellaneous Lubrication	4-3
4.6	Belts.....	4-3
4.7	Drive Belt Adjustment.....	4-4
4.8	Feed Track Chain Tension.....	4-7
4.9	Up/Down System.....	4-8
4.10	Long-Term Storage	4-8
4.11	End of the life cycle.....	4-9
4.12	Safety Devices Inspection	4-10
SECTION 5 ALIGNMENT		5-1
5.1	Alignment Procedures	5-1
5.2	Blade Installation And Tracking	5-2
5.3	Blade Wheel Alignment	5-4
5.4	Saw Head Adjustment.....	5-10
5.5	Blade Guide Arm Vertical Adjustment	5-11
5.6	Blade Guide Arm Horizontal Adjustment.....	5-12
5.7	Aligning the Blade Guides	5-14
5.8	Blade Deflection.....	5-15
5.9	Blade Guide Vertical Tilt Adjustment.....	5-16
5.10	Blade Guide Spacing	5-18
5.11	Blade Guide Horizontal Tilt Adjustment	5-19
5.12	Blade Height Scale Adjustment.....	5-20
5.13	Adjustment of the Sensor Activating the Air Cylinder	5-21
SECTION 6 SPECIFICATIONS		6-1
6.1	Overall Dimensions	6-1
6.2	Cutting Capacity.....	6-6
6.3	Blade Motor Specifications	6-7

Table of Contents

Section-Page

6.4	Noise Level.....	6-7
6.5	V-Belt Sizes.....	6-8
6.6	Air Supply Specification	6-9
6.7	Dust Extractor Specifications	6-9
SECTION 7	MOTOR BRAKE	7-1
7.1	Maintenance/repair	7-1
	<i>Wear of spring – applied brakes</i>	
	<i>Inspections</i>	
	<i>Maintenance intervals</i>	
7.2	Maintenance	7-2
	<i>Checking the rotor thickness</i>	
	<i>Check air gap</i>	

Getting Service

Wood-Mizer is committed to providing you with the latest technology, best quality and strongest customer service available on the market today. We continually evaluate our customers' needs to ensure we're meeting current wood-processing demands. Your comments and suggestions are welcome.

General Contact Information

From Europe call your local distributor or our European Headquarters and Manufacturing Facility in Koło, Nagórna 114 St, Poland at **+48-63-2626000**. From the continental U.S., call our U.S. Headquarter 8180 West 10th St. Indianapolis, IN 46214, toll-free at **1-800-525-8100**. Ask to speak with a Customer Service Representative. Please have your machine identification number and your customer number ready when you call. The Service Representative can help you with questions about the operation and maintenance of your machine. He also can schedule you for a service call.

Office Hours:

Country	Monday - Friday	Saturday	Sunday
Poland	7 a.m.- 3 p.m.	Closed	Closed
US	8 a.m.- 5 p.m.	8 a.m.- 12 p.m	Closed

Please have your vehicle identification number and your customer number ready when you call.



Wood-Mizer will accept these methods of payment:

- Visa, Mastercard, or Discover
- COD
- Prepayment
- Net 15 (with approved credit)

Be aware that shipping and handling charges may apply. Handling charges are based on size and quantity of order.

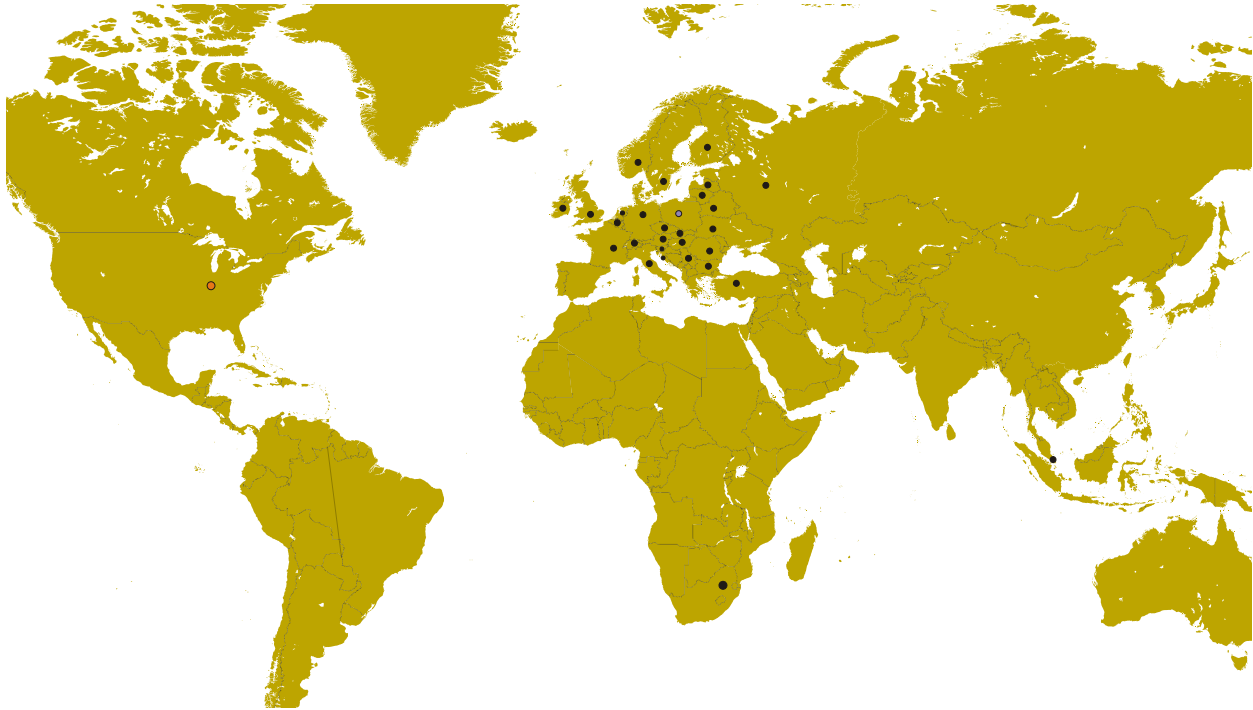
Branches & Authorized Sales Centers Wood-Mizer Locations (North and South America)



EUROPE		UNITED STATES
<p> European Headquarters Wood-Mizer Industries Sp. z o.o. Nagórna 114, 62-600 Kolo, Poland Tel.: +48-63-26-26-000 Fax: +48-63-27-22-327 www.woodmizer.eu</p>		<p> World Headquarters Wood-Mizer LLC 8180 West 10th Street Indianapolis, Indiana 46214-2400, USA Tel.: +1-317-271-1542 Fax: +1-317-273-1011 www.woodmizer.com</p>
<p>BELARUS MOST-GRUPP Siemashko 15, k.3 Minsk 2200116 Tel.: +375-17-270-90-08 Fax: +375-17-270-90-08 GSM: +375-29-649-90-80 e-mail: most-by@mail.ru</p>	<p>SWITZERLAND Bruno Steiner Striegelgasse 2 CH-6214 Schenkon Tel.: +41-41-921-13-01 Fax: +41-41-922-18-87 e-mail: info@mobilsaegen.ch</p>	<p>RUSSIA Dariusz Mikołajewski OOO WOOD-MIZER INDUSTRIES 141031, Moscow Reg., Mytishenski raj., pos. Veshki, Zavodskaja str., 3B Tel.Fax: +7(495) 788-72-35 Tel.Fax: +7(495) 641-51-60 e-mail: dariuszm@woodmizer-moscow.ru</p>
<p>BULGARIA Kalin Simeonov Ecotechproduct 38 Star Lozenski pat str. Sofia 1186 Tel.: +359-2-462-7035 Tel.: +359-2-963-1656 Tel./Fax : +359-2-979-1710 Kalin Simeonov GSM: +3592-963-2559 e-mail: office@ecotechproduct.com</p>	<p>HUNGARY Wiktor Turoczy Wood-Mizer Hungary K.F.T. Szonyi Ut 67., 2921 Komárom Tel./Fax: +36-34-346-255 e-mail: woodmizer@woodmizer.hu</p>	<p>RUSSIA Far East Wladimir Glazaczew "WM Service" Krasnoretschenskaya Str.111 680006 Khabarovsk Tel./Fax: +7-914-541-1183 e-mail: wms-khv@mail.ru</p>

<p>CROATIA Krešimir Pregernik Pregimex d.o.o. S. Batušića 31, 10090 Zagreb Tel./Fax: +3851-38-94-668 Krešimir Pregernik GSM: +3851-98-207-106 e-mail: Kresimir.Pregernik@gmail.com</p>	<p>ITALY Pasquale Felice Wood-Mizer Italia Srl Cda. Capoiaccio SN 86012 Cercemaggiore Campobasso Tel./Fax: +39-0874-798-357 GSM: +39-333-281-03-79 e-mail: wmitaliasrl@gmail.com</p>	<p>SERBIA Dragan Markov Wood-Mizer Balkan d.o.o. Svetosavska GA 3/3; P. Fah 25 23 300 Kikinda Tel./Fax: +381-230-25-754 Tel./Fax: +381-230-23-567 GSM: +381-63-568-658 e-mail: office@woodmizer.co.yu</p>
<p>CZECH REPUBLIC Miroslaw Greill Wood-Mizer CZ s.r.o. Osvaldova 91 339 01 Klatovy-Luby Tel./Fax: +420-376-312-220 Fax: +420-376-319-011 Miroslaw Greill GSM: +420-723-580-799 e-mail: greill@woodmizer.cz</p>		<p>SLOVAKIA Wiktor Turoczy Wood-Mizer Danubia s.r.o. Hadovce 5, 94501 Komárno Tel.: +421-35-77-40-316 Fax: +421-35-7740-326 GSM: +421-905-930-972 e-mail: woodmizer@woodmizer.sk</p>
<p>CZECH REPUBLIC Lubomir Kudlik Wood-Mizer Moravia Sovadinova 6 69002 Breclav Tel./Fax: +420-519-322-443 Lubomir Kudlik GSM: +420-602-734-792 e-mail: info@wood-mizer.net</p>	<p>LATVIA Vilmars Jansons OBERTS Ltd Gaujas str. 32/2 LV-2167 Marupe, Rigas Raj. Tel.: +371-7-810-666 Fax: +371-7-810-655 Vilmars Jansons GSM: +371-92-06-966 Andris Orols GSM: +371-28-33-07-90 e-mail: andris@oberts.lv</p>	<p>TURKEY Er-Ka Ahsap Profil Kerestecilik San. ve Tic. Ltd. Sti. Adana Keresteciler Sitesi 191 sk No.41 ADANA Tel.: +90-322-346-15-86 Fax: +90-322-345-17-07 GSM: +90-533-363-18-44 e-mail: info@erkaahsap.com.tr</p>
<p>FINLAND Howard Blackbourn Oy Falkberg Jordbruk Ab Falkintie 220 25610 Ylonkyla Tel.: +358-2732-2253 Fax: +358-2732-2263 Howard Blackbourn GSM: +358-440-424-339 e-mail: falkberg@woodmizer.fi</p>	<p>LITHUANIA Andrius Zuzevicius UAB Singlis Savanoriu pr. 187, 2053 Vilnius Tel.: +370-5-2-32-22-44 Fax: +370-5-2-64-84-15 GSM: +370-620-28-645 e-mail: andrius.z@singlis.lt</p> <p>Dmitrij Gaiduk GSM: +370-69-84-51-91 e-mail: dmitrijus.g@singlis.lt</p>	<p>UKRAINE Ivan Vinnicki MOST UKRAINA bul. Myru 3, Bajkivtsi Ternoplskyj r-j Ternopolska oblast 47711 Ukraine Tel/Fax: +38 (0352) 52 37 74 GSM: +38 (067) 352 54 34 GSM: +38 (067) 674 50 68 E-mail: most-ukraina@ukr.net</p>
<p>FRANCE Tizoc Chavez Wood-Mizer France 556 chemin des Embouffus, ZAC des Basses Echarrieres 38440 SAINT JEAN DE BOURNAY Tel: +33-4 74 84 84 44 GSM: +33-607 52 02 82 Mail: tchavez@woodmizer.fr</p>	<p>NORWAY Odd Edvoll Wood-Mizer Nordic AS Vardelia 17, 2020 Skedsmokorset Tel.: +47-63-87-49-89 Fax: +47-63-87-37-66 GSM: +47-930-42-335 e-mail: odd.edvoll@woodmizer.no</p> <p>e-mail: firmapost@woodmizer.no</p>	<p>UNITED KINGDOM & IRELAND Wood-Mizer UK Hopfield Barn Kenward Road, Yalding Kent ME18 6JP, UK Tel.: +44-1622-813-201 Fax: +44-1622-815-534 e-mail: info@woodmizer.co.uk</p>
<p>SLOVENIA Jan Fale FAMTEH d.o.o. Gacnikova pot 2, 2390 Ravne na Koroskem Tel.: +386-2-62-04-232 Fax: +386-2-62-04-231 Jan Fale GSM: +386-2-62-04-230 e-mail: jan.fale@famteh.si</p> <p>Matjaz Kolar Tel.: +386-2-62-04-232 GSM: +386-31-775-999 e-mail: matjaz.kolar@famteh.si</p>		

<p>GERMANY Klaus Longmuss Wood-Mizer Sägewerke GmbH Dorfstraße 5, 29485 Schletau Tel.: +49-5883-9880-10 Fax: +49-5883-9880-20 e-mail: info@woodmizer.de</p> <p>Klaus Longmuss Tel.: +49-5883-9880-12 GSM: +49-17-298-55-892 e-mail: KLongmuss@woodmizer.de</p>	<p>Subagent: SWEDEN Kjell Larsson Mekwood AB Slingan 14, 812 41 Gästrike-Hammarby Tel.: +46-290-515-65 Kjell Larsson GSM: +46-706-797-965 e-mail: kjell.larsson@mekwood.se</p>	<p>IRELAND Wood-Mizer Ireland Stephen Brennan Cum Lahardane Ballina County Mayo Tel:+353 96 51345</p> <p>E-mail: brennanmill@ericom.net</p>
<p>Subagents: DENMARK Brian Jensen Arnborgvej 9, 7330 Brande- Fasterholt Tel.: +45-971-88-265 Fax: +45-971-88-266</p> <p>Brian Jensen GSM: +45-23-49-5828 e-mail: Fasterholt-Savvaerk@Mail.Tele.dk</p>	<p>ROMANIA Adrian Echert SC WOOD-MIZER RO SRL TRANSILVANIEI Nr. 5 Sibiu, Cisnădie 555300 Tel./Fax: : +40-369-405-433 GSM: +40-745-707-323 e-mail: aechert@woodmizer.ro</p>	<p>Regional Manager - Asia Wood-Mizer Asia Pte Ltd. James Wong Tel: +65 81216910 Fax: +65 6283 8636 WWW: www.woodmizerasia.com E-mail: jwong@woodmizerasia.com</p>
<p>Netherlands Chris Dragt Lange Brink 77d, 7317 BD Apeldoorn Tel.: +31-55312-1833 Fax: +31-55312-2042 e-mail: Info@dragtbosbouw.nl</p>	<p>Subagent: ROMANIA M. Echert S.C. Echert Comprod s.r.l Str. Schitului Nr. 6, Apt.7 etajul-1 725 70 Vatra Dornei, Romania Tel./Fax: +40-230-374-235 Tel. : +40-740-35-35-74</p>	<p>Regional Manager - Africa Wood-Mizer Africa Jean-Jacques Oelofse UNIT 3, LEADER PARK, NO: 20 CHARIOT ROAD STORMILL, EXT 5, Roodepoort, Johannesburg Tel: +27 011 473 1313 Fax: +27 011 473 2005 Jean-Jacques Oelofse E-mail: jjoelofse@woodmizerafrika.com Jean-Jacques Oelofse Skype:jean.jacques.pierre.oelofse</p>

USA World Headquarters

Serving North & South America, Oceania, East Asia

Wood-Mizer LLC
8180 West 10th Street
Indianapolis, IN 46214

Phone: 317.271.1542 or 800.553.0182
Customer Service: 800.525.8100
Fax: 317.273.1011
Email: infocenter@woodmizer.com

Brazil Headquarters

Serving Brazil

Wood-Mizer do Brasil
Rua Dom Pedro 1, No: 205 Bairro: Sao Jose
Ivoti/RS CEP:93.900-000

Tel: +55 51 9894-6461/ +55 21 8030-3338/ +55 51
3563-4784
Email: info@woodmizer.com.br

Canadian Headquarters

Serving Canada

Wood-Mizer Canada
396 County Road 36, Unit B
Lindsay, ON K9V 4R3

Phone: 705.878.5255 or 877.357.3373
Fax: 705.878.5355
Email: ContactCanada@woodmizer.com

Europe Headquarters

Serving Europe, Africa, West Asia

Wood-Mizer Industries Sp z o.o.
Nagorna 114
62-600 Kolo, Poland

Phone: +48.63.26.26.000
Fax: +48.63.27.22.327

Branches & Authorized Sales Centers

For a complete list of dealers, visit www.woodmizer.com

SECTION 1 SAFETY

1.1 Safety Symbols

The following symbols and signal words call your attention to instructions concerning your personal safety. Be sure to observe and follow these instructions.

 **DANGER!** indicates an imminently hazardous situation which, if not avoided, will result in death or serious injury.

 **WARNING!** suggests a potentially hazardous situation which, if not avoided, could result in death or serious injury.

 **CAUTION!** refers to potentially hazardous situations which, if not avoided, may result in minor or moderate injury or damage to equipment.

 **IMPORTANT!** indicates vital information.

NOTE: gives helpful information.

 Warning stripes are placed on areas where a single decal would be insufficient. To avoid serious injury, keep out of the path of any equipment marked with warning stripes.

1.2 Safety Instructions



IMPORTANT! The Resaw is intended for sawing wood only. The resaw must not be used for other purposes such as cutting ice, metal or any other materials. [See Section 5.2](#) for log size capacities of the machine.

IMPORTANT! The operator of the resaw should get adequate training in the operation and adjustment of the machine.

NOTE: ONLY safety instructions regarding personal injury are listed in this section. Caution statements regarding only equipment damage appear where applicable throughout the manual.

Observe Safety Instructions



IMPORTANT! Read the entire Operator's Manual before operating the resaw. Take notice of all safety warnings throughout this manual and those posted on the machine. Keep this manual with this machine at all times, regardless of ownership.

Also read any additional manufacturer's manuals and observe any applicable safety instructions including dangers, warnings, and cautions.

Only adult persons who have read and understood the entire operator's manual should operate the resaw. The resaw is not intended for use by or around children.

IMPORTANT! It is always the owner's responsibility to comply with all applicable federal, state and local laws, rules and regulations regarding the ownership and operation of your Wood-Mizer resaw. All Wood-Mizer resaw owners are encouraged to become thoroughly familiar with these applicable laws and comply with them fully while using the machine.



Wear Safety Clothing



WARNING! Secure all loose clothing and jewelry before operating the resaw. Failure to do so may result in serious injury or death.

WARNING! Always wear gloves and eye protection when handling bandsaw blades. Changing blades is safest when done by one person! Keep all other persons away from area when coiling, carrying or changing a blade. Failure to do so may result in serious injury.

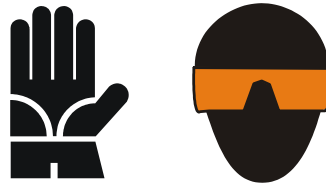

WARNING! Always wear eye, ear, respiration, and foot protection when operating or servicing the resaw.



Keep Resaw And Area Around Resaw Clean



DANGER! Maintain a clean and clear path for all necessary movement around the resaw and lumber stacking areas. Failure to do so will result in serious injury.

Dispose Of Sawing By-Products Properly



IMPORTANT! Always properly dispose of all sawing by-products, including sawdust and other debris.

Check Resaw Before Operation



DANGER! Make sure all guards and covers are in place and secured before operating the resaw. Failure to do so may result in serious injury.



Keep Persons Away



DANGER! Keep all persons out of the path of moving equipment and lumber when operating the resaw. Failure to do so will result in serious injury.

DANGER! Always be sure all persons are out of the path of the blade before starting the motor. Failure to do so will result in serious injury.



WARNING! Allow blade to come to a complete stop before opening the blade housing cover. Failure to do so will result in serious injury.

1 Safety

Keep Hands Away

Keep Hands Away



DANGER! Always shut off the blade motor before changing the blade. Failure to do so will result in serious injury.

DANGER! Motor components can become very hot during operation. Avoid contact with any part of a hot motor. Contact with hot motor components can cause serious burns. Therefore, never touch or perform service functions on a hot motor. Allow the motor to cool sufficiently before beginning any service function.

DANGER! Always keep hands away from moving bandsaw blade. Failure to do so will result in serious injury.

DANGER! Always be aware of and take proper protective measures against rotating shafts, pulleys, fans, etc. Always stay a safe distance from rotating members and make sure that loose clothing or long hair does not engage rotating members resulting in possible injury.



WARNING! Use extreme caution when spinning the blade wheels by hand. Make sure hands are clear of blade and wheel spokes before spinning. Failure to do so may result in serious injury.

Use Proper Maintenance Procedures



DANGER! Make sure all electrical installation, service and/or maintenance work is performed by a qualified electrician and is in accordance with applicable electrical codes.

DANGER! Hazardous voltage inside the electric boxes and at the motor can cause shock, burns, or death. Disconnect and lock out power supply before servicing! Keep all electrical component covers closed and securely fastened during resaw operation.



WARNING! Consider all electrical circuits energized and dangerous.

WARNING! Disconnect and lock out power supply before servicing the resaw! Failure to do so may result in serious injury.

WARNING! Never assume or take the word of another person that the power is off; check it out and lock it out.

WARNING! Do not wear rings, watches, or other jewelry while working around an open electrical circuit.

WARNING! Remove the blade before performing any service to the motor or resaw. Failure to do so may result in serious injury.

DANGER! Never clean the blade or blade wheels using the hand-held brush or scraper whilst the resaw blade is in motion.

CAUTION! Before installation of the blade, inspect it for damage and cracks. Use only properly sharpened blades. Always handle the blade with extreme caution. Use suitable carrier equipment for transporting the blades.

1

Safety

Keep Safety Labels In Good Condition

CAUTION! Always wear gloves when handling the blade. Never grab the blade with bare hands!

CAUTION! If the blade breaks during resaw operation, push the EMERGENCY STOP button to stop the blade motor and wait 10 seconds before you open the blade housing cover.

CAUTION! The resaw's work-stand should be equipped with a 4 kg or bigger dry powder extinguisher.

Keep Safety Labels In Good Condition





IMPORTANT! Always be sure that all safety decals are clean and readable. Replace all damaged safety decals to prevent personal injury or damage to the equipment. Contact your local distributor, or call your Customer Service Representative to order more decals.

IMPORTANT! If replacing a component which has a safety decal affixed to it, make sure the new component also has the safety decal affixed.

See Table 1-1. Pictogram decals used to warn and inform the user about danger in the resaw.

TABLE 1-1

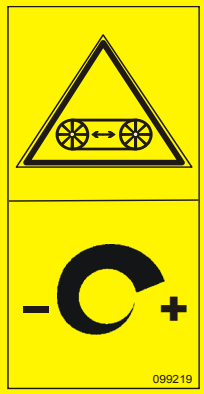
Decal View	W-M No.	Description
	096317	CAUTION! Read thoroughly the manual before operating the machine. Observe all safety instructions and rules when operating the resaw.
	099220	CAUTION! Close all guards and covers before starting the machine.
	099219	Blade tension. Turning the bolt clockwise will increase the blade tension and turning the bolt counterclockwise will decrease the tension.

1 Safety
 Keep Safety Labels In Good Condition

TABLE 1-1



	<p>099221</p>	<p>CAUTION! Keep all persons a safe distance away from work area when operating the machine.</p>
	<p>099222</p>	<p>CAUTION! Sawdust outlet. Protect eyes!</p>
	<p>096321</p>	<p>Blade movement direction</p>
	<p>S12004G</p>	<p>CAUTION! Always wear safety goggles when operating the resaw!</p>

TABLE 1-1

	S12005G	CAUTION! Always wear protective ear muffs when operating the resaw!
	501465	CAUTION! Always wear safety boots when operating the resaw
	512107	CAUTION! Always wear safety gloves when operating the resaw
	501467	Lubrication Point
 <p style="text-align: center; font-size: small;">P11789b</p>	P11789	Aligning the blade on the wheels

1 Safety
Keep Safety Labels In Good Condition

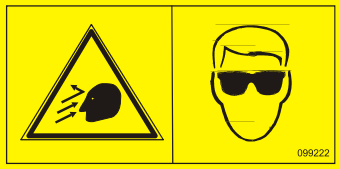
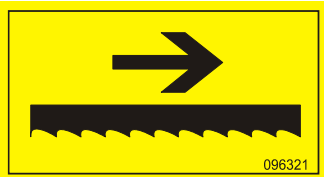
TABLE 1-1

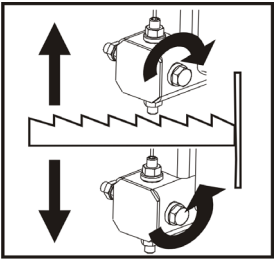





	P85070	CE sign																											
	099401	Russian safety certification sign																											
	S20097	Motor rotation direction																											
 <table border="1" data-bbox="448 1379 576 1496"> <thead> <tr> <th>d</th> <th>Linear speed</th> </tr> </thead> <tbody> <tr> <td>257mm</td> <td>18 m/s</td> </tr> <tr> <td>231mm</td> <td>20 m/s</td> </tr> <tr> <td>197mm</td> <td>24 m/s</td> </tr> </tbody> </table>	d	Linear speed	257mm	18 m/s	231mm	20 m/s	197mm	24 m/s	509025	Blade drive wheel diameter-blade linear speed																			
d	Linear speed																												
257mm	18 m/s																												
231mm	20 m/s																												
197mm	24 m/s																												
	505346	Tensioner Valve Handle Placement, TVS																											
<table border="1" data-bbox="240 1771 592 1962"> <thead> <tr> <th rowspan="2">Type</th> <th colspan="2">505346</th> <th rowspan="2">psi</th> <th rowspan="2">bar</th> </tr> <tr> <th>F[mm]</th> <th>E[mm]</th> </tr> </thead> <tbody> <tr> <td>275</td> <td>1,07</td> <td>32</td> <td>830-850</td> <td>57-59</td> </tr> <tr> <td>375 376</td> <td>1,14</td> <td>32 38</td> <td>745-765</td> <td>51-53</td> </tr> <tr> <td>2735</td> <td>1,07</td> <td>35</td> <td>805-825</td> <td>55-57</td> </tr> <tr> <td>576 476</td> <td>1,27 1,40</td> <td>38</td> <td>715-735</td> <td>49-51</td> </tr> </tbody> </table>	Type	505346		psi	bar	F[mm]	E[mm]	275	1,07	32	830-850	57-59	375 376	1,14	32 38	745-765	51-53	2735	1,07	35	805-825	55-57	576 476	1,27 1,40	38	715-735	49-51	505348	Blade Tension Values
Type		505346				psi	bar																						
	F[mm]	E[mm]																											
275	1,07	32	830-850	57-59																									
375 376	1,14	32 38	745-765	51-53																									
2735	1,07	35	805-825	55-57																									
576 476	1,27 1,40	38	715-735	49-51																									

TABLE 1-1

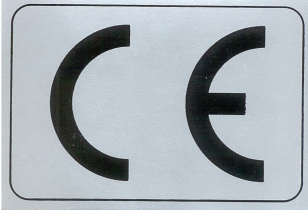
	<p>101176</p>	<p>CAUTION! Compressed air in the system even after electric power disconnection.</p>
	<p>513181</p>	<p>Pressure value of the pneumatic system.</p>

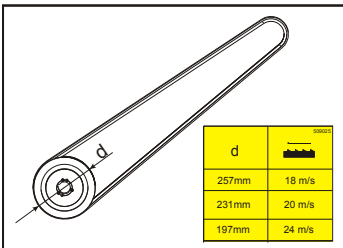
SECTION 2 OPERATION

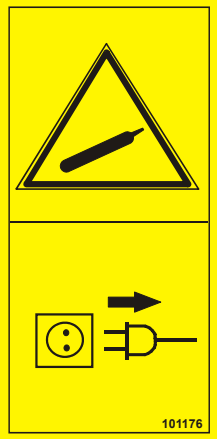
2.1 Control Overview

See Figure 2-1. The control panel includes switches to start and stop the feed track and the saw head.

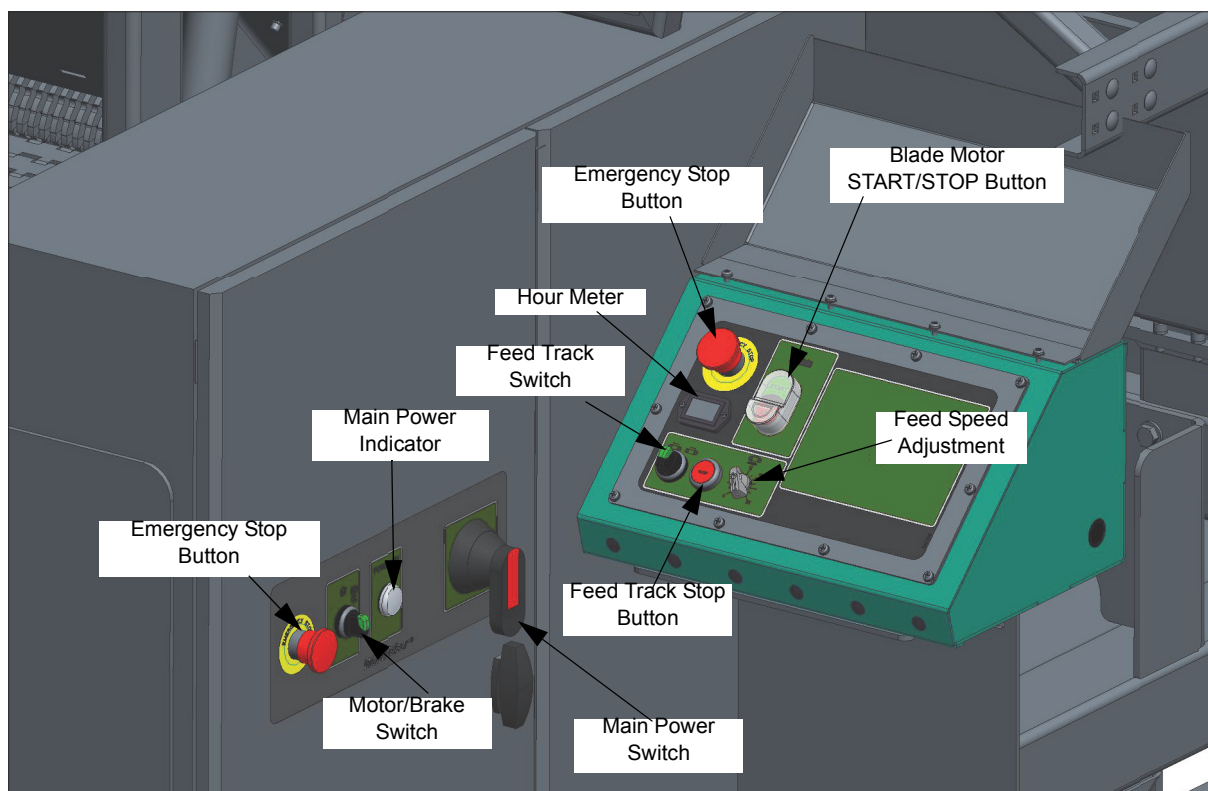





FIG. 2-1 CONTROL PANEL AND MAIN ELECTRIC BOX

Control Panel

1. Blade Drive

 To start the blade motor, turn the key switch to the  position. Then press the START button. To stop the blade motor, press the STOP switch.

2. Feed Track

 To start spinning the feed track forward or backward, turn the switch left or right. To stop the feed track, press the STOP button

3. Feed Track Speed Adjustment



The feed track speed switch controls the speed at which the feed track moves. Turn the switch clockwise to increase the speed, counterclockwise to reduce the speed.

4. Emergency Stop

Push the emergency stop button to stop the blades and the track feed motor. Turn the emergency stop clockwise to release the stop. The resaw will not restart until the emergency stop is released.



5. Hour Meter

Records work hours of the machine.

Main Electric Box

1. Key Switch

The key switch has three positions:

- “0” position - all electrical circuits are off,
-  position - all electrical circuits are on,
-  position - releases the motor disk brake; the blade and the track feed motors are off.

2. Emergency Stop

Push the emergency stop button to stop the blades and the track feed motor. Turn the emergency stop clockwise to release the stop. The resaw will not restart until the emergency stop is released.

3. Main Power Switch

Disconnects power from all electric circuits of the machine.

2.2 Resaw Setup

The Horizontal Resaw is delivered to the customer place in modules. The HR modules must be mounted together.

See Figure 2-2. Dismount the electric up/down system assembly (optional equipment) from the transport bracket (1). Next dismount the transportation bracket from the resaw base (2). The up/down assembly is heavy (about 90kg). To lift it, use a belt and a winch or a forklift.

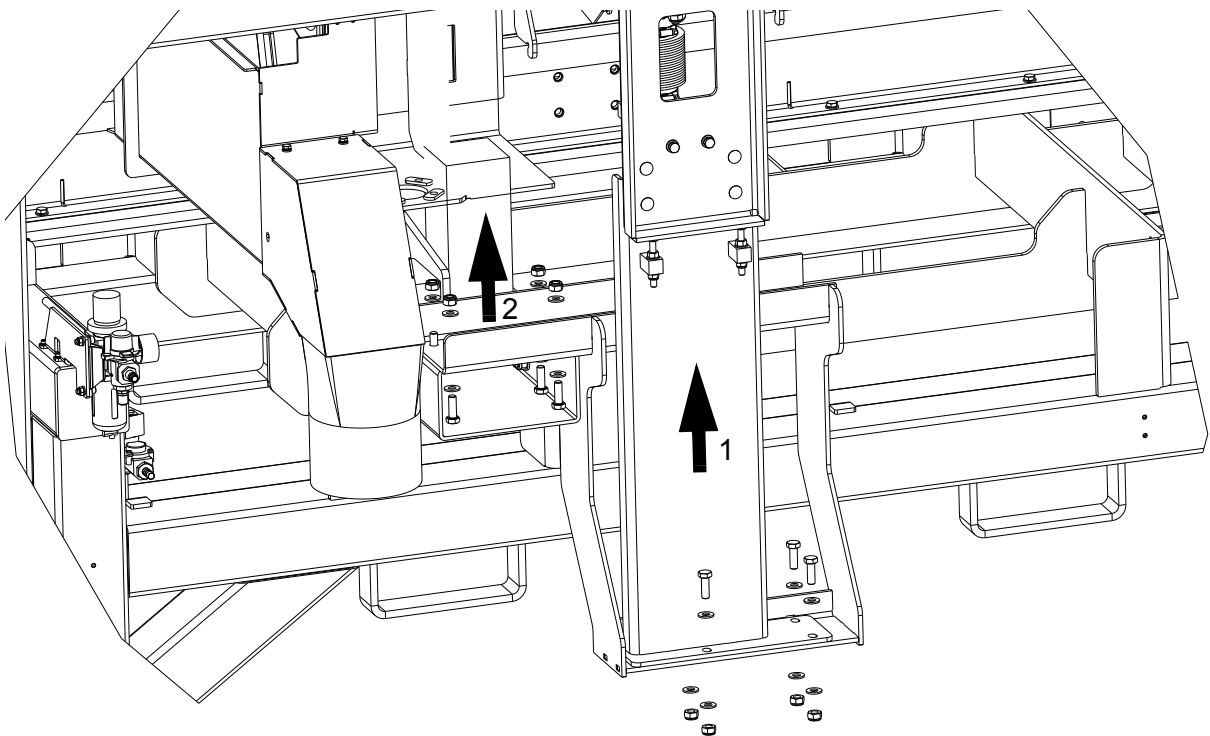

FIG. 2-2

See **Figure 2-3**. Mount the up/down assembly in its working position as shown on the pictures below.

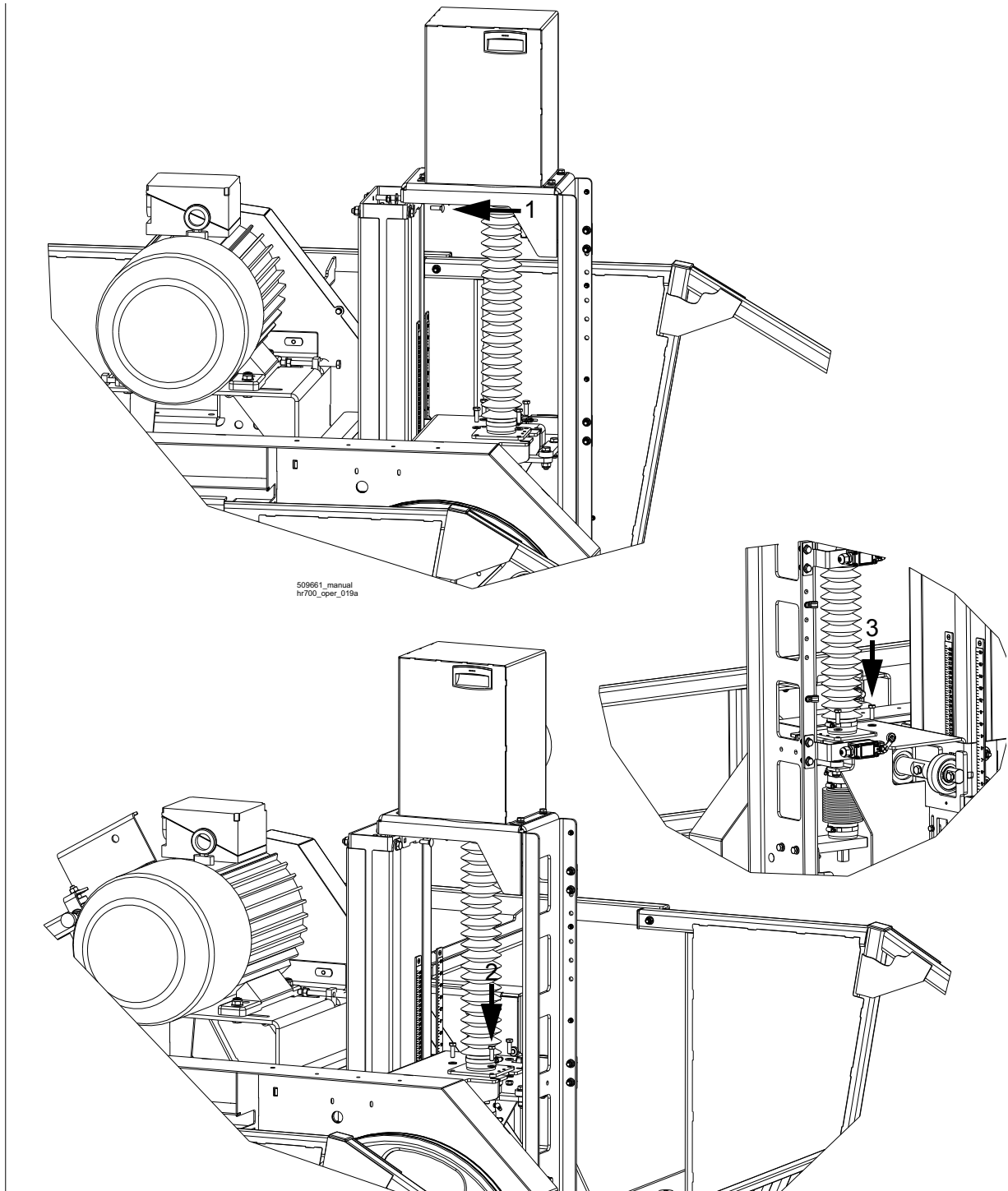

FIG. 2-3

See Figure 2-4. Attach the base to the additional module (or modules).

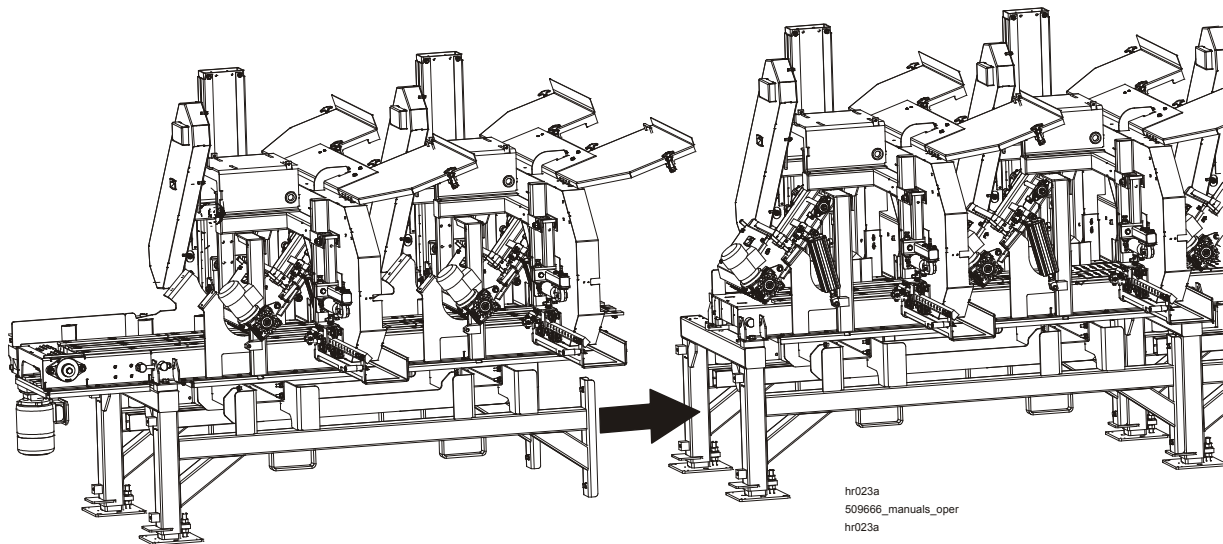

FIG. 2-4

See Figure 2-5. Using the appropriate bolts, washers and nuts, mount the base and the

additional module (modules) together.

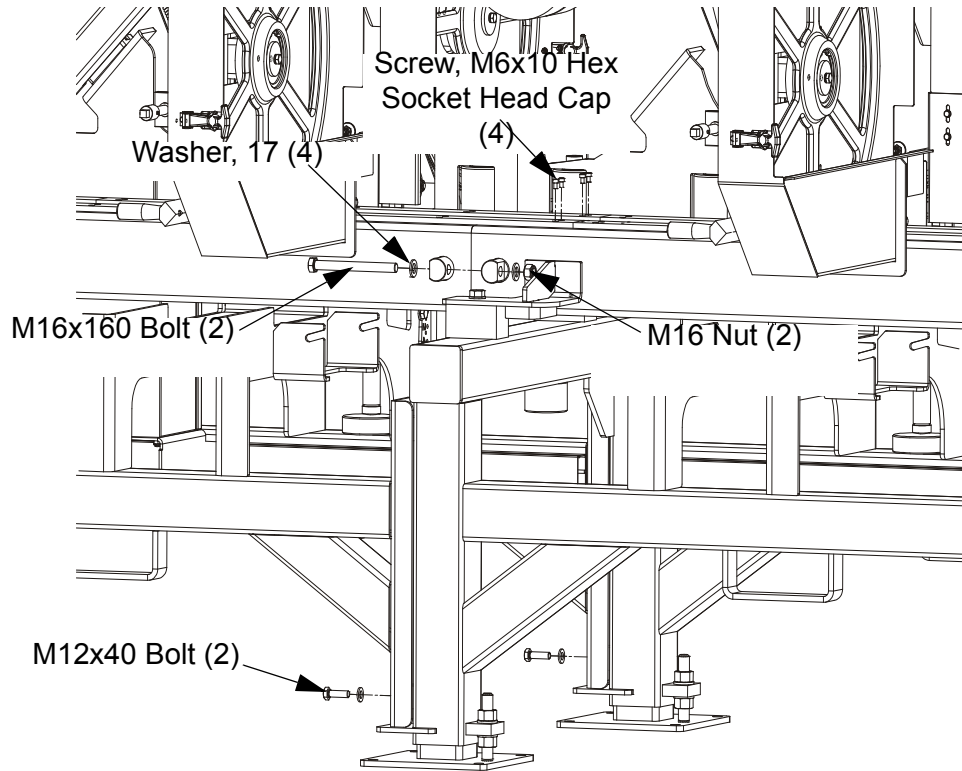

FIG. 2-5

See Figure 2-6. Mount the feed chain drive module.

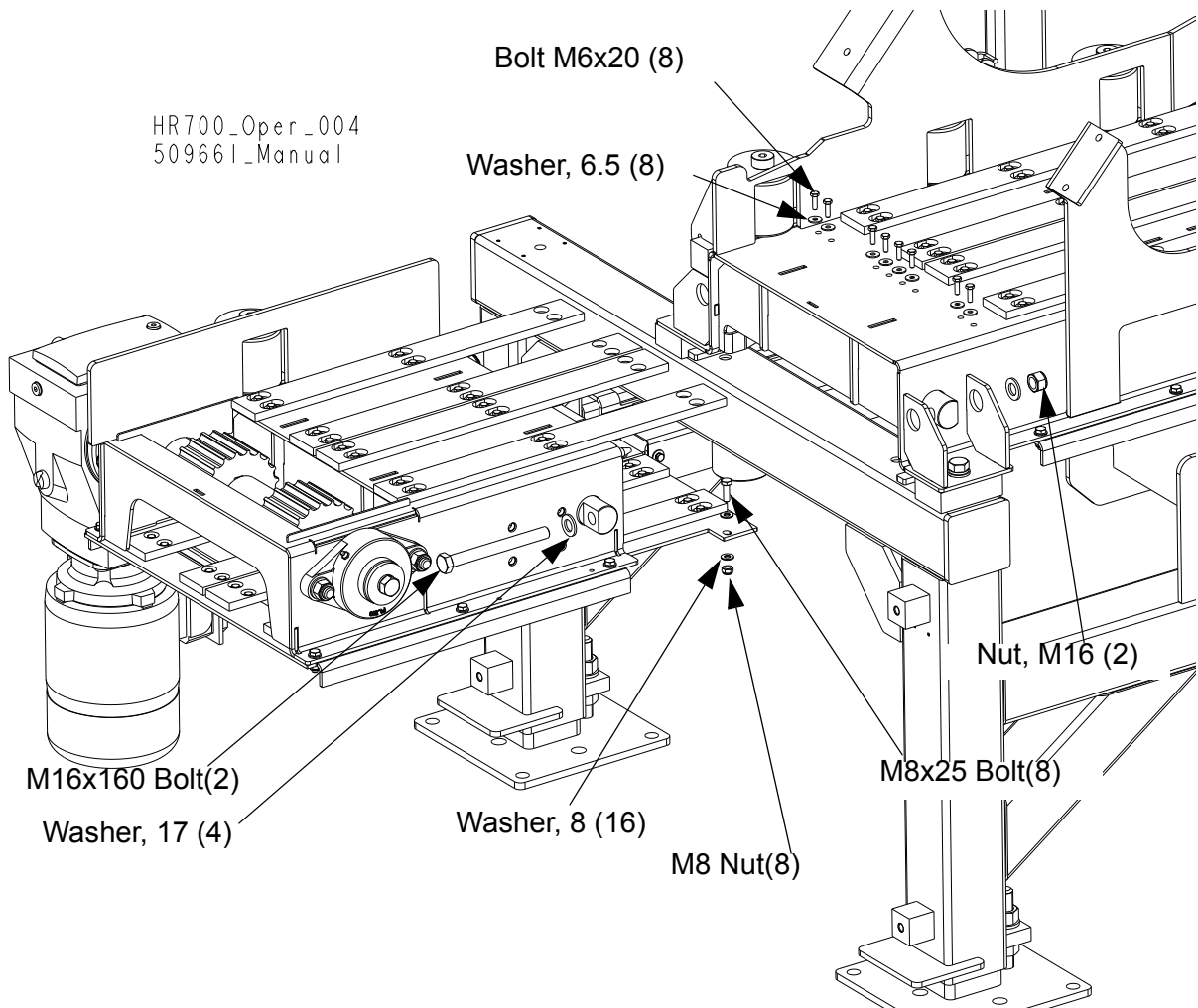

FIG. 2-6

See Figure 2-7. Mount the feed chain and apply proper tension. [See Section 4.8](#)

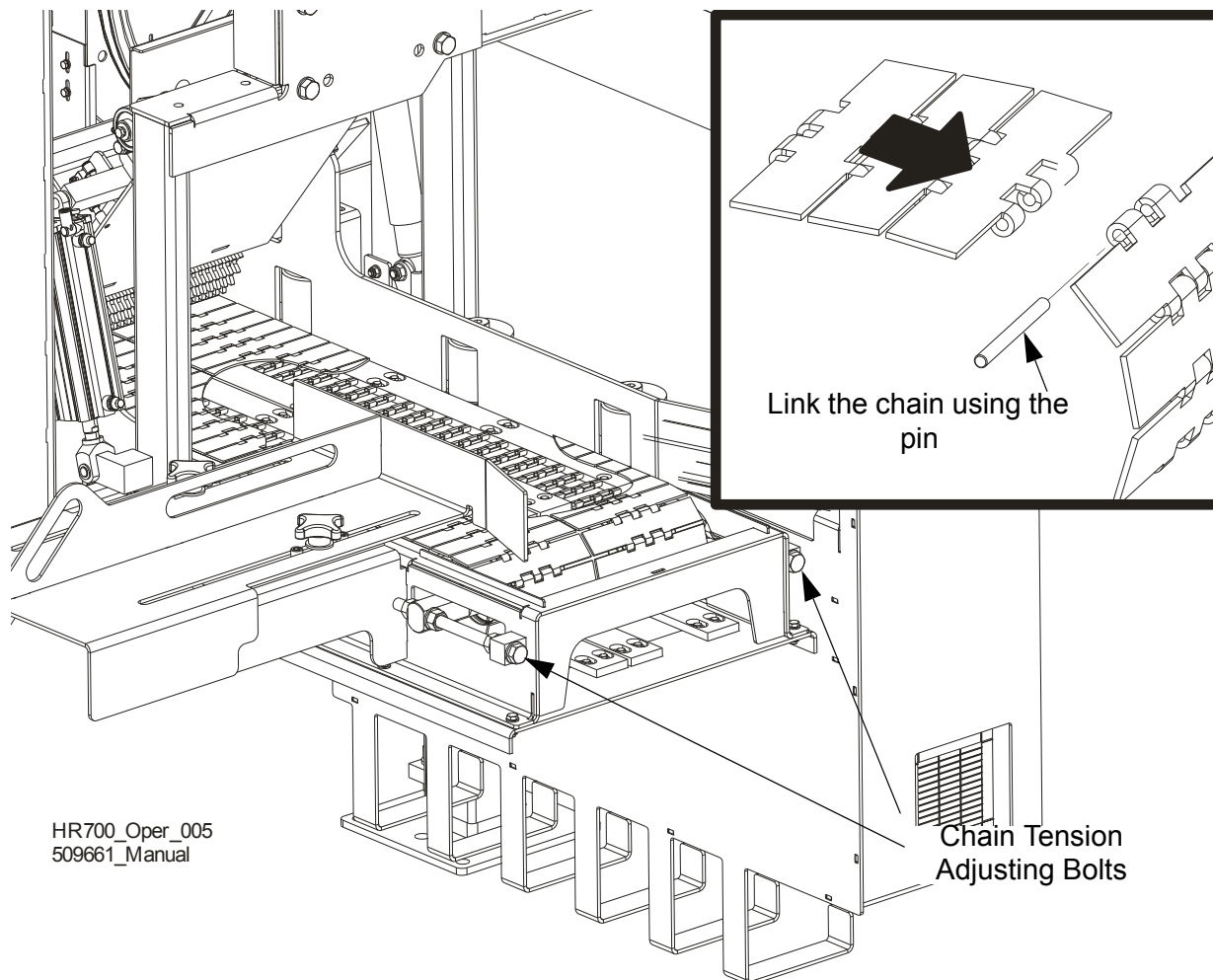

FIG. 2-7



IMPORTANT! Before starting to use any HR resaw equipped with return tables, move the control panel and the rear e-stop to the locations shown in the figures 2-9 to 2-12 (depending on the resaw configuration).



IMPORTANT! Before starting to use the resaw, you have to meet the following conditions:

- Set up the resaw on firm and level ground. The machine must be fastened to the floor. Failure to do so may cause the sawhead to tip, resulting in serious injury or death. A concrete foundation or pads and anchored bolts are recommended.
- The resaw can be operated with the sawdust collection system only.

2 Operation

Resaw Setup

- The resaw can't be operated outdoor when it is raining/snowing and in case of rain/snow the resaw must be stored under roof or indoor.
- The resaw can be operated in temperature range from -15° C to 40° C (5°F to 104°F) only.
- The illumination at the operator's position must be at least 300lx¹.
- Have a qualified electrician install the power supply (according to EN 60204 Standard). The power supply must meet the specifications given in the table below.



DANGER! It is recommended that a 30mA Ground Fault Interrupter (GFI) be used.

See Table 2-1. Depending on the number of saw heads, you should use different circuit breakers and power cord cross sections. See the tables below for the required connection specifications.

Number of saw heads/ Main motors power	Total Power	Circuit Breaker [A]	Power Cord Cross Section [mm ²]
1 11kW (E15)	12,5kW at 230/400V 50Hz 14,4kW at 460V 60Hz	25	13 AWG/ 2,5
2 11kW (E15)	23,5kW at 230/400V 50Hz 27,1kW at 460V 60Hz	40	9 AWG/ 6
3 11kW (E15)	34,5kW at 230/400V 50Hz 39,6kW at 460V 60Hz	70	5 AWG/ 16
4 11kW (E15)	45,5kW at 230/400V 50Hz 52,3kW at 460V 60Hz	90	3 AWG/ 25
5 11kW (E15)	56,5kW at 230/400V 50Hz 65kW at 460V 60Hz	120	1 AWG/ 35
6 11kW (E15)	67,5kW at 230/400V 50Hz 77,6kW at 460V 60Hz	140	1 AWG/ 35
1 15kW (E20)	17kW at 230/400V 50Hz 19,5kW at 460V 60Hz	32	11 AWG/ 4
2 15kW (E20)	32kW at 230/400V 50Hz 37kW at 460V 60Hz	63	7 AWG/ 10
3 15kW (E20)	47kW at 230/400V 50Hz 54kW at 460V 60Hz	90	5 AWG/ 16

TABLE 2-1

4 15kW (E20)	62kW at 230/400V 50Hz 71kW at 460V 60Hz	120	3 AWG/ 25
5 15kW (E20)	77kW at 230/400V 50Hz 88,5kW at 460V 60Hz	140	1 AWG/ 35
6 15kW (E20)	93kW at 230/400V 50Hz 106kW at 460V 60Hz	180	0 AWG/ 50
1 18,5kW (E25)	20kW at 230/400V 50Hz 23kW at 460V 60Hz	40	9 AWG/ 6
2 18,5kW (E25)	38,5kW at 230/400V 50Hz 44kW at 460V 60Hz	80	5 AWG/ 16
3 18,5kW (E25)	54kW at 230/400V 50Hz 62kW at 460V 60Hz	100	3 AWG/ 25
4 18,5kW (E25)	72,5kW at 230/400V 50Hz 83,5kW at 460V 60Hz	140	1 AWG/ 35
5 18,5kW (E25)	91kW at 230/400V 50Hz 105kW at 460V 60Hz	180	0 AWG/ 50
6 18,5kW (E25)	109,5kW at 230/400V 50Hz 126kW at 460V 60Hz	200	0 AWG/ 50

TABLE 2-1

- Locate the air assembly at the right side of the machine. Connect the incoming air supply line to the fitting. Make sure the air gauge indicates 0,6MPa (6bar) Adjust the pressure if needed. To adjust the pressure, lift the black cap located behind the air gauge. Turn the cap clockwise to increase pressure, turn the cap counterclockwise to decrease pressure. Push the cap down to secure when adjustment is complete. Air supply cut-off valve should be used to disconnect air supply and release compressed air from the pneumatic system. Set the cut-off valve to "SUP." position for normal operation or to "Exh." to release compressed air.



WARNING! Disconnect air supply and release compressed air from the air system before servicing the saw! Failure to do so may result in serious injury.

2 Operation

Electrical Requirements (US Version Only)

See Figure 2-8.

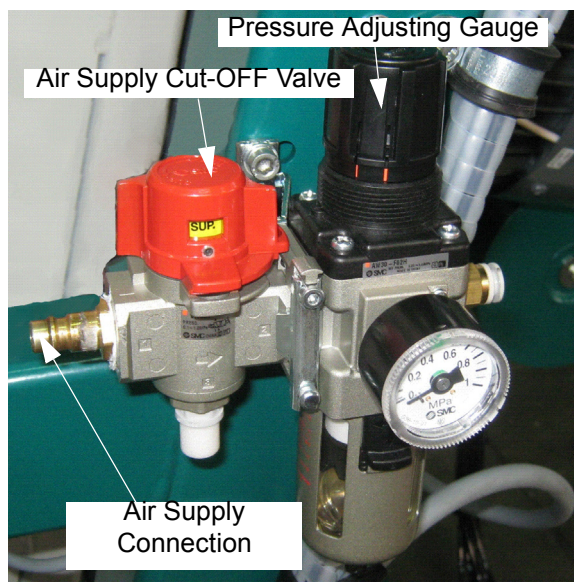

FIG. 2-8

Electrical Requirements (US Version Only)

DANGER! Make sure all electrical installation, service and/or maintenance work is performed by a qualified electrician and is in accordance with applicable electrical codes.

CAUTION! The resaw motors and the transformer are prewired for 480 V, 60 Hz power supplies. If you plan to use a 480 V, 60 Hz mill with another type of power supply, you will need to rewire the motor to avoid damage to the machine.

The electrical requirements for the resaw are listed below. **IMPORTANT!** The resaw is wired for use with a 480 volt power supply. To operate the resaw with 240V or 380-415V power supplies, a transformer is required. Refer to the table below:

See Table 2-2.

Conversion From/To	240 to 480 volts			380-415 to 480 volts		
	2	4	6	2	4	6
Mfg. Part No.	EE30T3118H	EE45T3065H	EE75T3065H	EE30T2611H	EE45T2611H	EE75T2611H
AWMV Part No.	069712	069711	068057	069616	068054	068055

TABLE 2-2

See Table 2-3. The machine FLA required for the resaw is listed below.

Motor HP	Power Supply			Machine FLA/# of Heads		
	Volts	PH	Hz	2	4	6
25	240 ¹	3	50/60	125	188	313
	380-415 ¹	3	50	75	113	188
	480	3	60	50	95	140

TABLE 2-3

¹ Transformer Required. FLAs include a transformer.

■ Operator's positions and E-STOP locations are shown in the figures below.

See Figure 2-9. Operator's position layout.

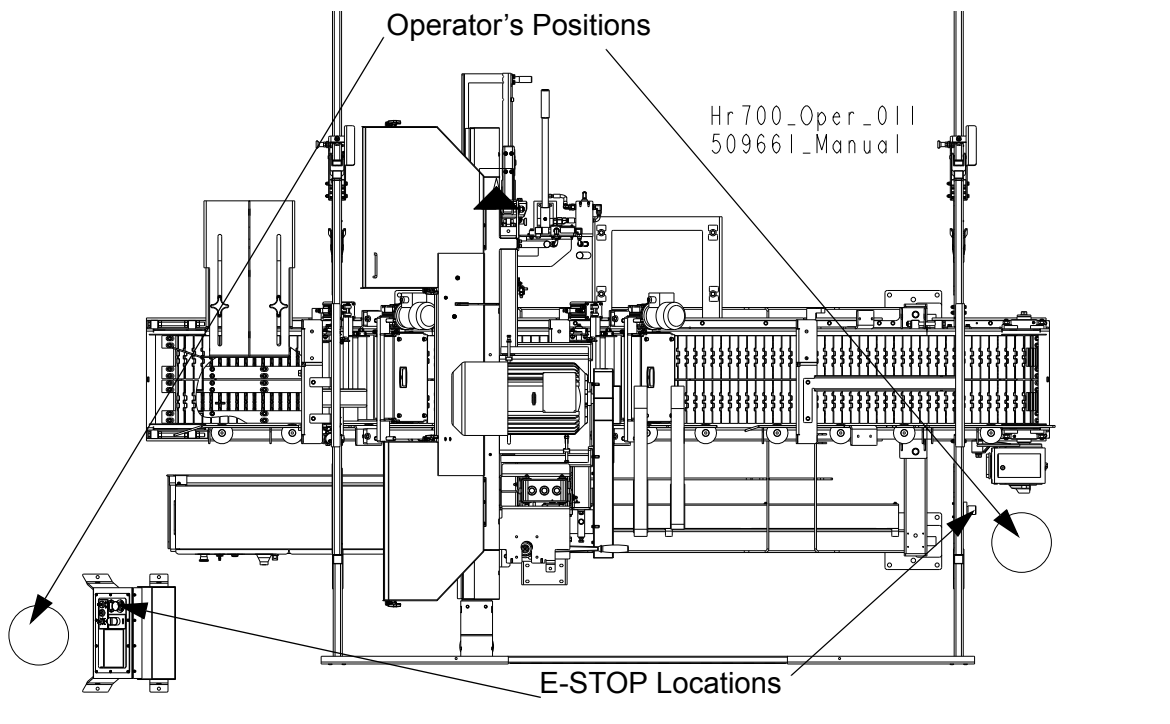

FIG. 2-9



IMPORTANT! When starting the machine for the first time, check that the main motor rotation direction is as indicated by the arrow located on the motor body (fan guard). If the rotation direction is incorrect, invert the phases in the phase

2

Operation

Electrical Requirements (US Version Only)

inverter located in the power socket (electric box). Setting the phases in the phase inverter correctly will ensure correct rotation directions of all resaw motors.

- The resaw can be lifted using a forklift only. The forklift must be rated for at least 2000kg (4410 lb). The HR modules must be separated before lifting. The resaw is equipped with forklift pockets. Insert the forks into the pockets shown in the figure below.

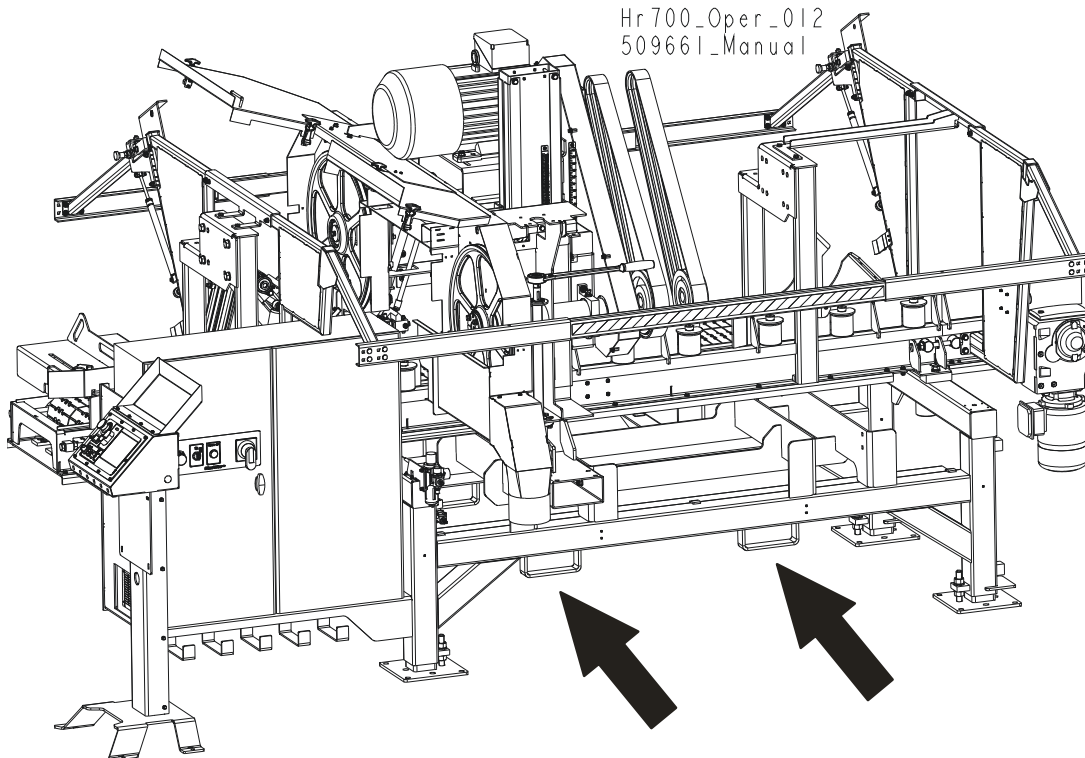

RYS. 2-10

2.3 Replacing The Blade



DANGER! Always shut off the resaw motor before changing the blade. Failure to do so may result in serious injury.



WARNING! Always wear gloves and eye protection whenever handling bandsaw blades. Changing blades is safest when done by one person! Keep all other persons away from work area when changing blades. Failure to do so may result in serious injury.



WARNING! In case of the blade brake, wait until all rotating parts are completely stop. Failure to do so may result in serious injury.

Raise the blade housing cover. Turn the blade tension valve handle to the “0” position to release the blade tension until the wheel is pulled in and the blade is lying loose in the

2 Operation

Replacing The Blade

blade housing. Lift the blade out of the blade housing.

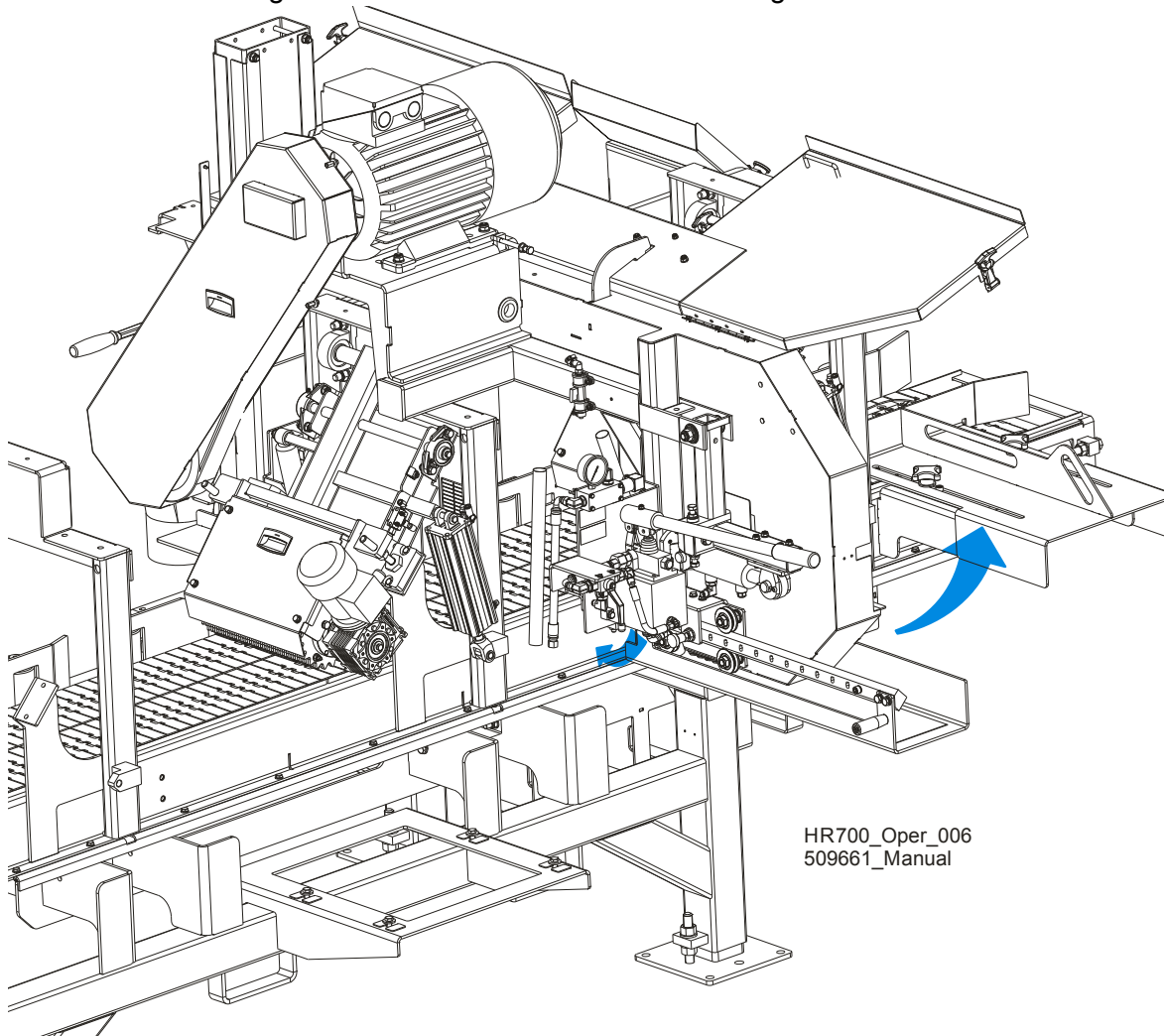

Install a new blade around the two blade wheels so that the teeth located between the blade guide assemblies point to the drive side of the machine. Make sure the teeth are pointing the correct direction.

Position 1 1/4" wide blades on the wheels so the gullet is 3.0 mm (1/8"), (± 1.0 mm (3/64")) out from the front edge of the wheel.

Close the blade housing cover.

Next, tension the blade as described in the following instructions.

2.4 Tensioning The Blade

See Figure 2-11. Place the provided handle in the blade tensioner socket and secure with a screw. Set the tensioner valve to the "1" position. Move the tensioner handle up and down to tension the blade. Depending on the installed blade type, tension the blade to the value shown on the decal located below the blade tension valve. The values "F" and "E" are: blade thickness and blade width. Check the blade tension occasionally when adjusting the cant control or while cutting and adjust if necessary. As the blade and belts heat up and stretch, the blade tension will change. Also, ambient temperature changes can cause tension to change. To release the blade tension, set the tensioner valve to the "0" position.

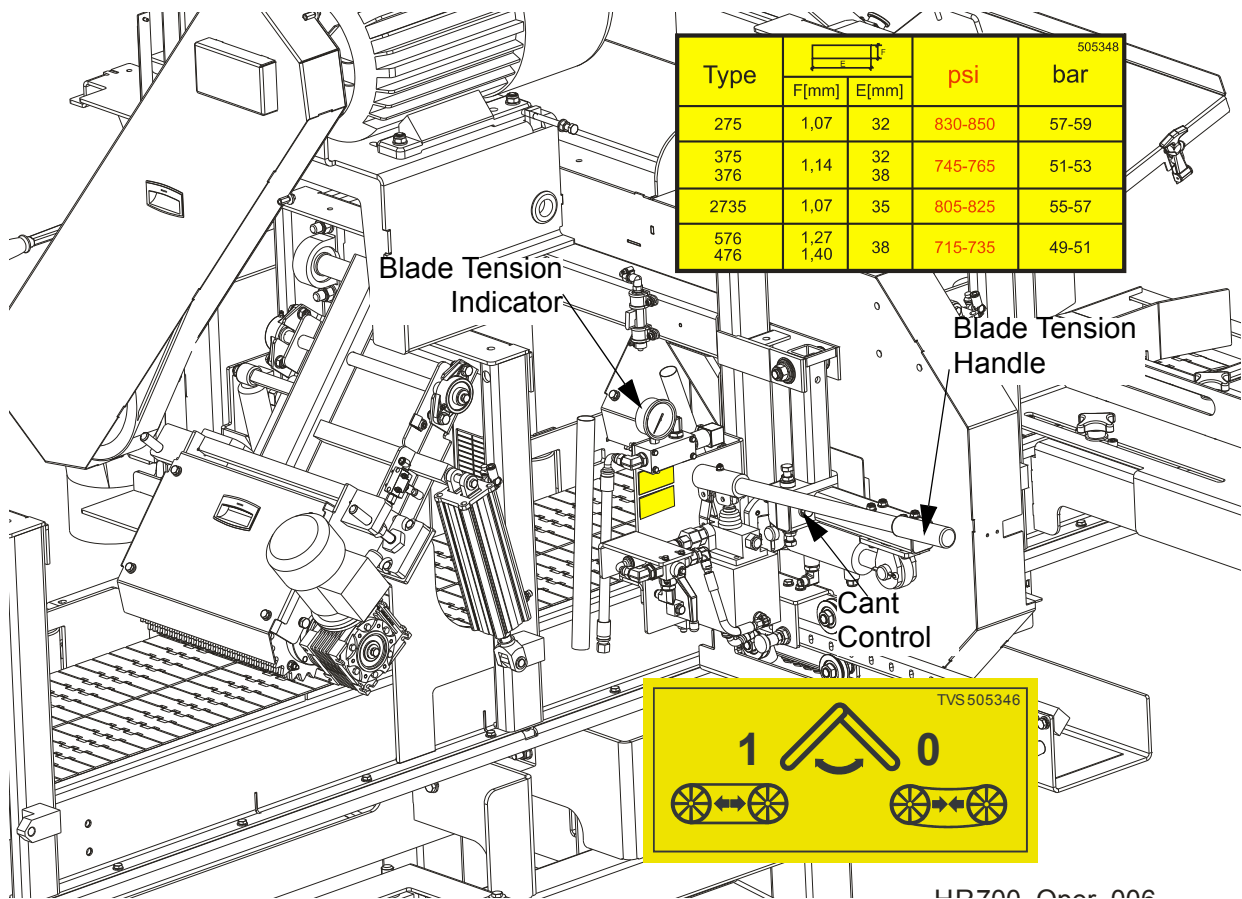

FIG. 2-11



CAUTION! Release the blade tension when the resaw is not in use (for example at the end of a shift). Tension the blade again before starting the motor.

2.5 Tracking The Blade

1. Open the blade housing cover.
2. Turn the key switch to the "H" position.



3. Manually spin one of the blade wheels until the blade positions itself on the blade wheels.
4. Check that the blade is properly positioned on the blade wheels.

See Figure 2-12. 1 1/4" wide blades should be placed on the blade wheels so that the gullet is 3.0 mm (1/8") ± 1.0 mm (3/64") out from the front edge of the wheel.

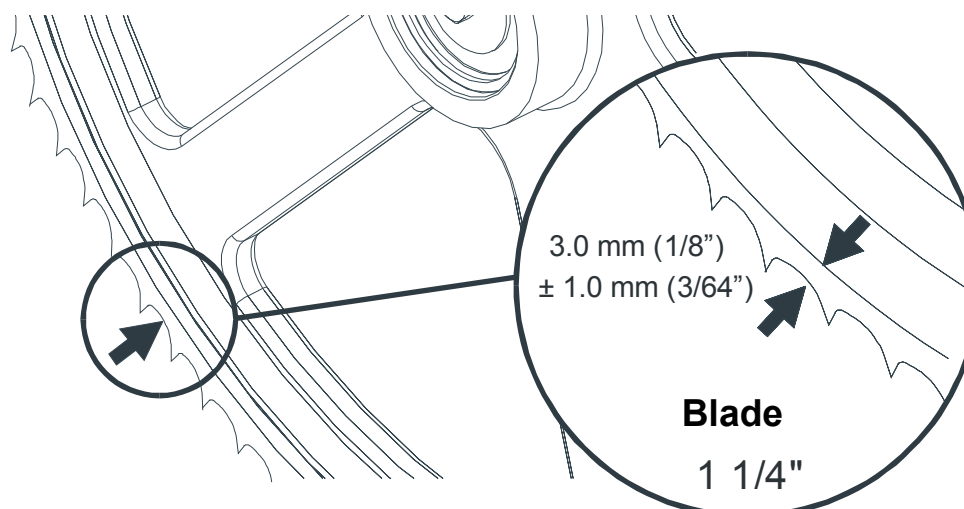

FIG. 2-12

5. Use the cant adjustment bolt, shown in **Figure 2-11**, to adjust where the blade travels on the blade wheels.

To move the blade out on the blade wheel, turn the cant adjustment bolt clockwise. To move the blade in on the blade wheel, turn the bolt counterclockwise.

6. Adjust the blade tension if necessary to compensate for any changes that may have occurred while adjusting the cant control.
7. Close the blade housing cover.



CAUTION! Make sure all guards and covers are in place and secured before operating or towing the resaw. Failure to do so may result in serious injury. Be sure the blade housing cover is in place and secured.

NOTE: After aligning the blade on the wheels, always check the blade guide spacing and location.

2.6 Saw Head Height Adjustment

You can raise or lower each individual saw head to determine the thickness of the finished stock. The saw heads should be adjusted so that the last blade the material passes through is closest to the feed track.

Example: You want to cut cants into 12.5 mm (1/2") pallet material. Assuming your resaw has six cutting heads, you will need to adjust each head in 14.0 mm (35/64") increments up from the feed track. This will allow 1.5 mm (1/16") kerf for each blade.

See Figure 2-13. The sixth saw head (the last one the material will pass through) should be adjusted to 12.5 mm (1/2") above the feed track. The fifth head should be adjusted to 26.5 mm (1 3/64") above the track, the fourth head to 40.5 mm (1 19/32"), etc....

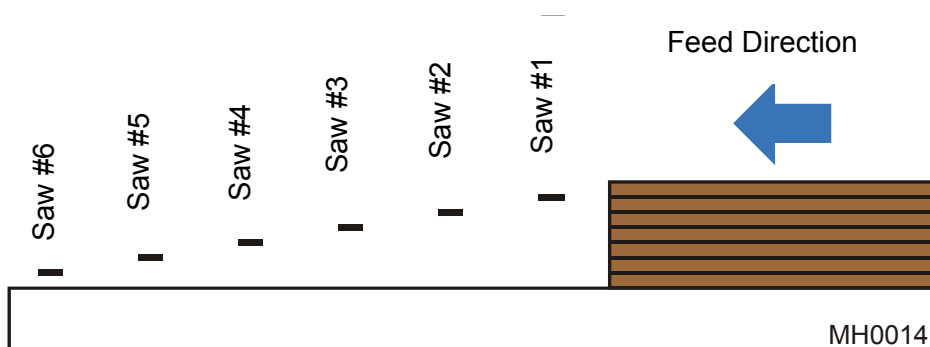

FIG. 2-13

1. Install a blade if needed and check for correct blade tension. ([See Section 2.4](#))
2. Set the saw head at the desired height. (The blade height scale shows the height of the blade above the feed track.)

See Figure 2-14. To raise or lower the saw head, use the acme screw as shown in the figure. Turn the screw clockwise to raise the saw head; counterclockwise to lower the saw

2 Operation

Saw Head Height Adjustment

head.

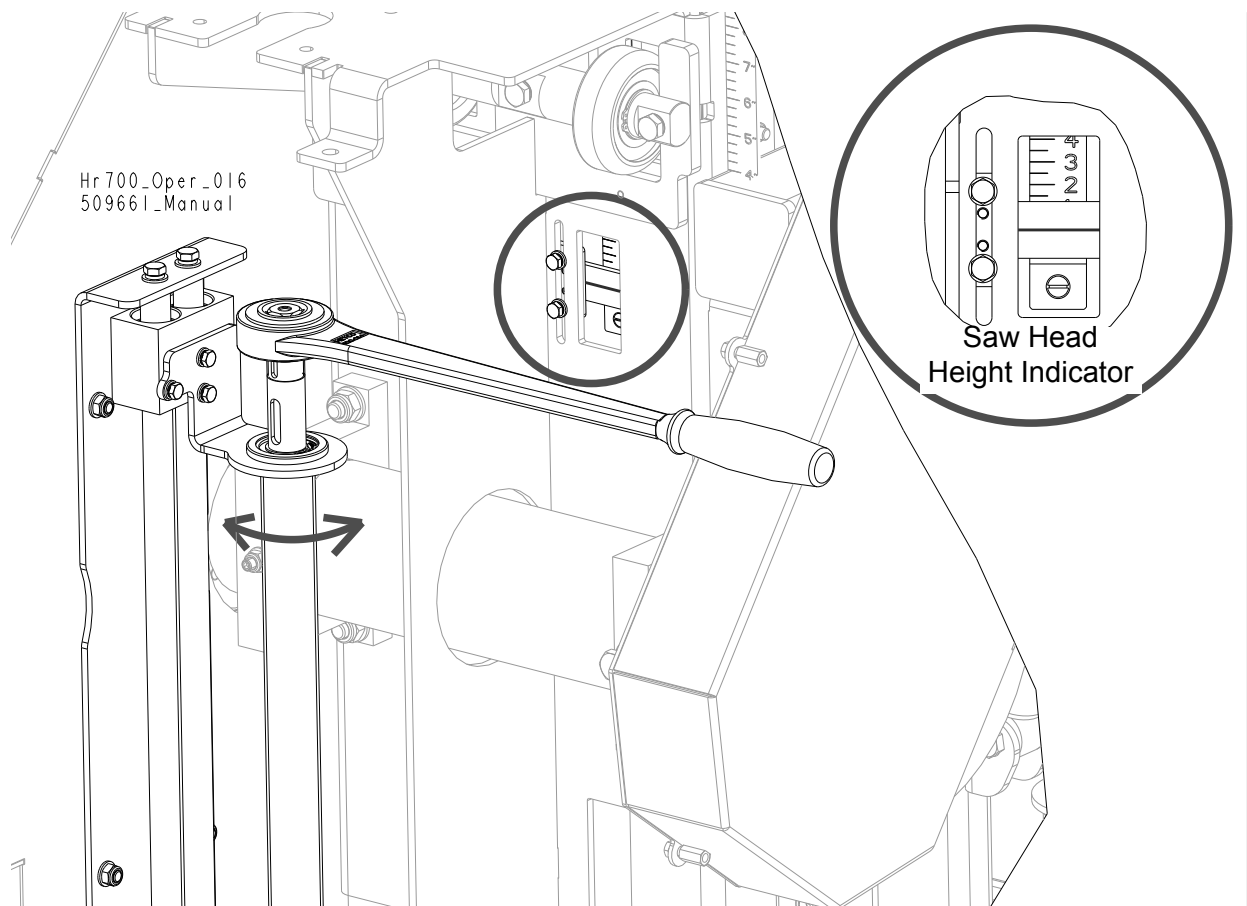

FIG. 2-14

NOTE: When adjusting the saw head height lower than 20mm (25/32"), adjust the blade guide arm so that it does not touch the feed chain.

See Figure 2-15.

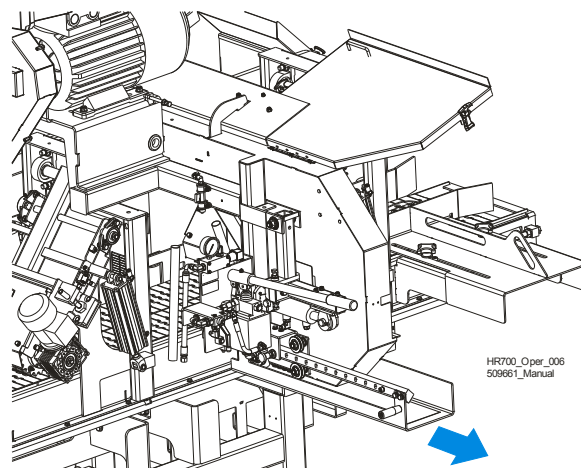
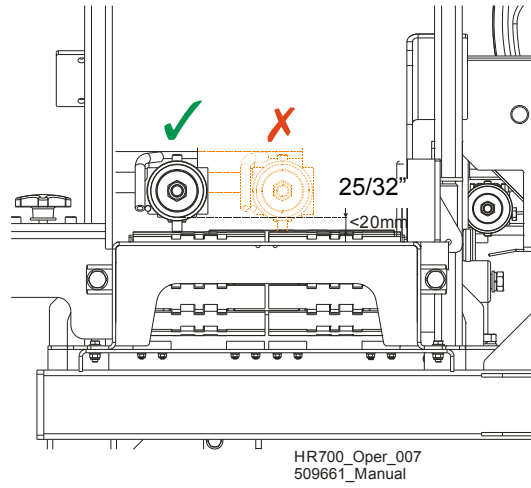

FIG. 2-15

2.7 Guide Fence Adjustment

See Figure 2-16. Loosen the knobs. Move the guide fence to the desired cant width.

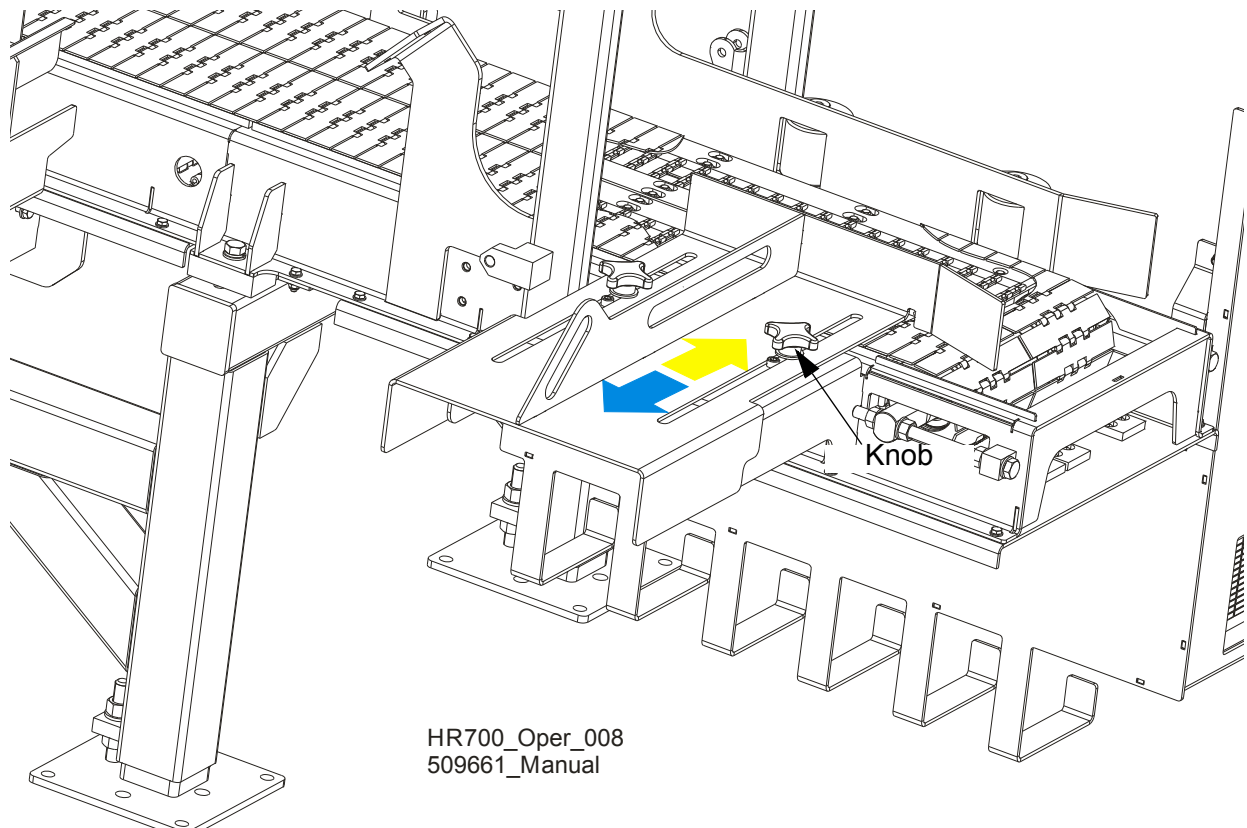

FIG. 2-16

2.8 Blade Guide Arm Adjustment

The outside blade guide arm can be adjusted in or out depending on the width of the material to be cut. The arm should be adjusted about 25 mm (63/64") wider than the material to be cut.

Example: If the material to be cut is 150 mm (5 29/32") wide, adjust the blade guide arm so the area between the blade guides is 175 mm (6 7/8") wide.

See Figure 2-17. To move the blade guide arm, unlock the locking pin and slide the arm in or out. Lock the locking pin.

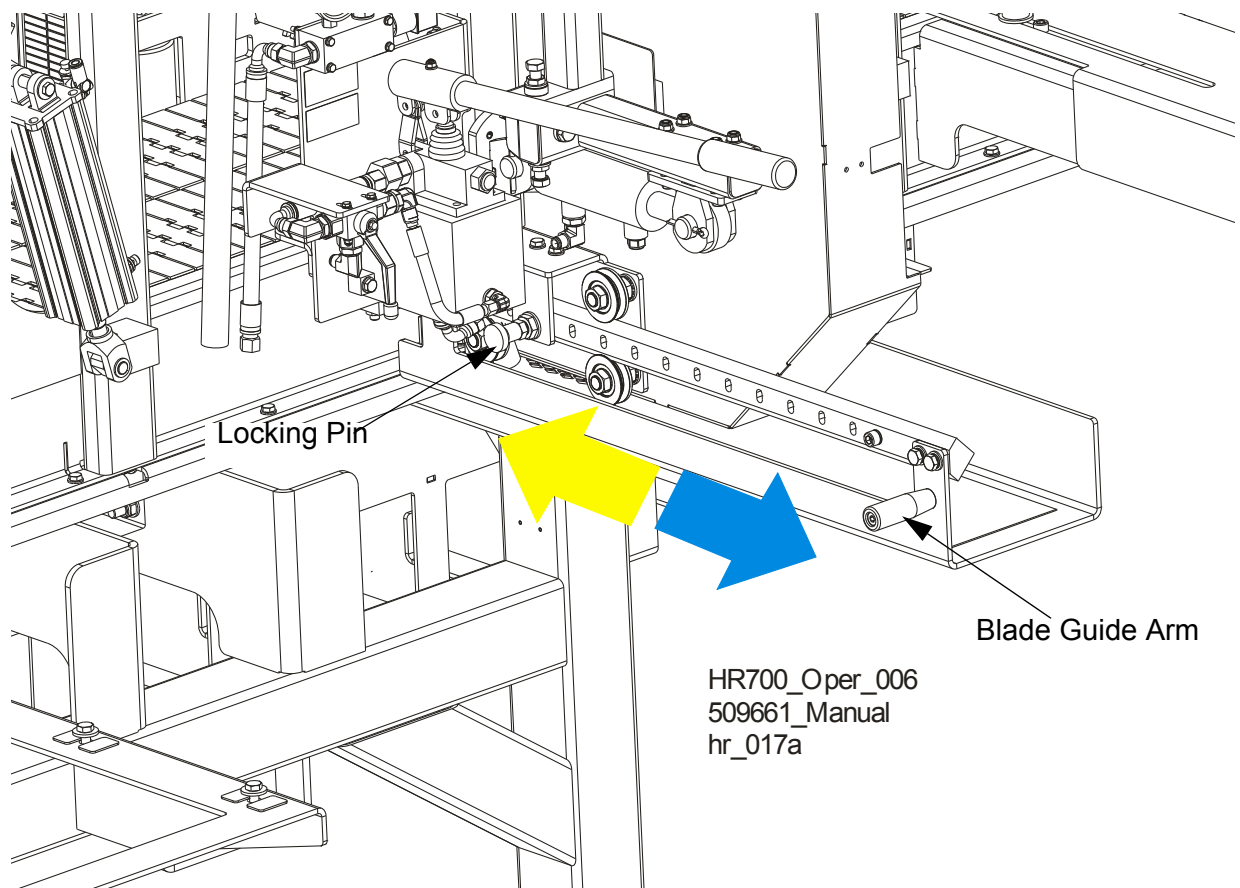



FIG. 2-17

2.9 Machine Start

 **DANGER!** Before starting the resaw, perform these steps to avoid injury and/or damage to the equipment:

- Close the blade housing cover and replace any guards removed for service.
- Check the feed track and remove all loose objects such as tools, wood, etc.
- Check that the blade is properly tensioned.
- Make sure all persons are at a safe distance from the machine.
- Check that the emergency stops are released.

NOTE: The resaw will not start if either of the emergency stops is on.

Before starting the saw heads, check that the main power switch servicing the resaw is on.

See Figure 2-18. Start the blade motors. To do this, turn the key switch to the  position and then press the START button on the control panel (see the figure below). The motors should start and the blades should start spinning.

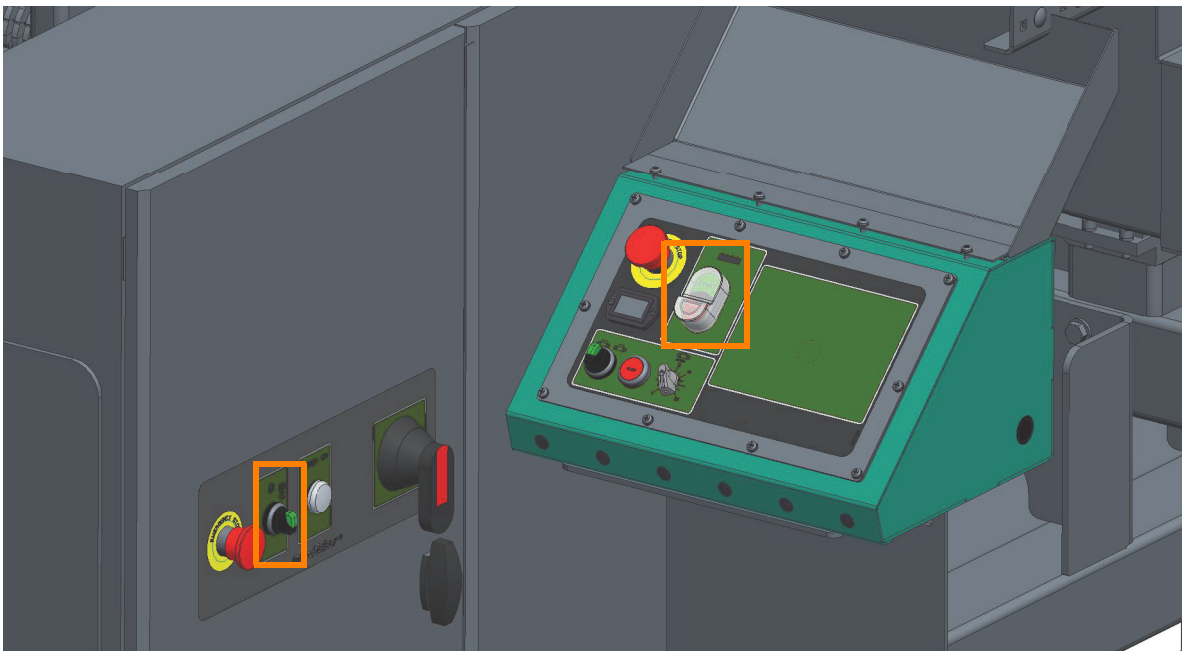

FIG. 2-18

To stop the blade motors, press the STOP button shown in the figure above. The blade motor also may be stopped by pushing either of the emergency stop buttons.

If either of the emergency stops has been used to stop the blade motor, rotate the switch clockwise before restarting the saw head. The saw head cannot be restarted until the emergency stop button is released.

See Figure 2-19. After the saw head has been successfully started, the feed track can be

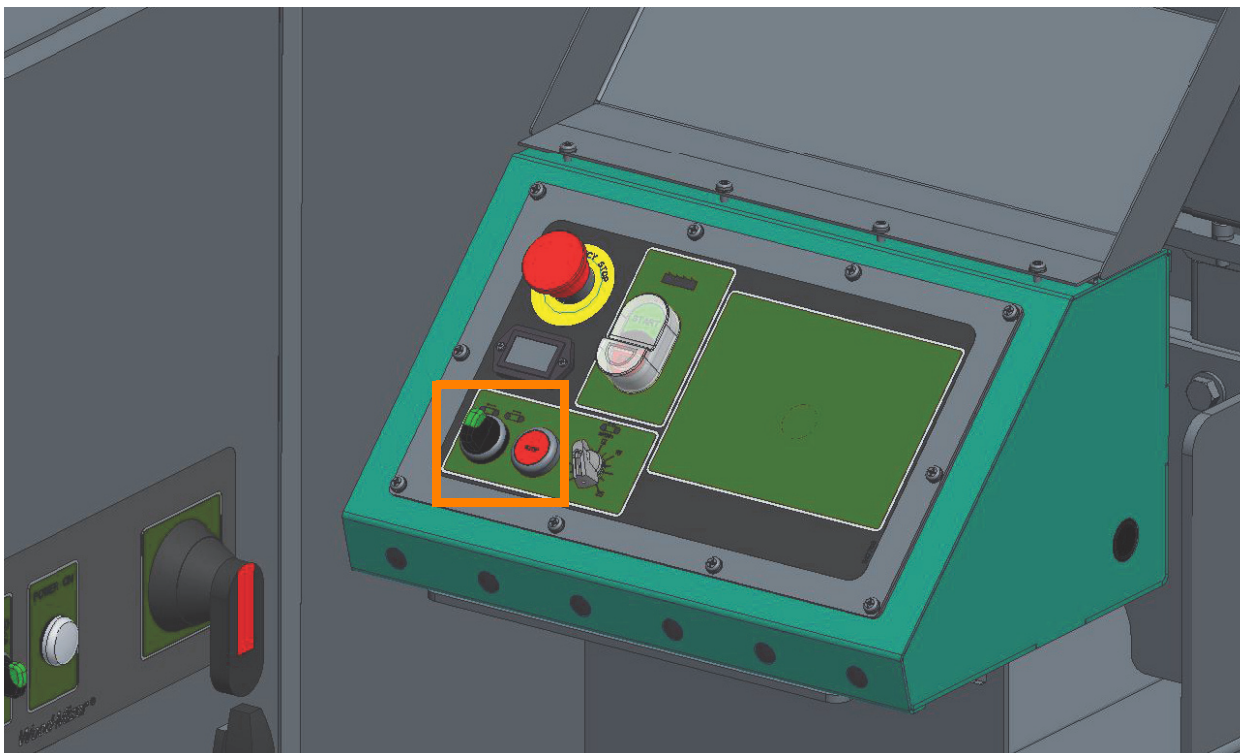

FIG. 2-19

started. To start the track feed, turn left the Track switch shown in Figure 2-5.

The feed track can be stopped either by pressing the STOP button or one of the emergency stop buttons. The emergency stop will also stop the blade motor.

NOTE: The feed track cannot be started if the blade motor is not started.

2 Operation

Machine Start

See Figure 2-20. The speed at which the feed track moves is adjustable. The feed track

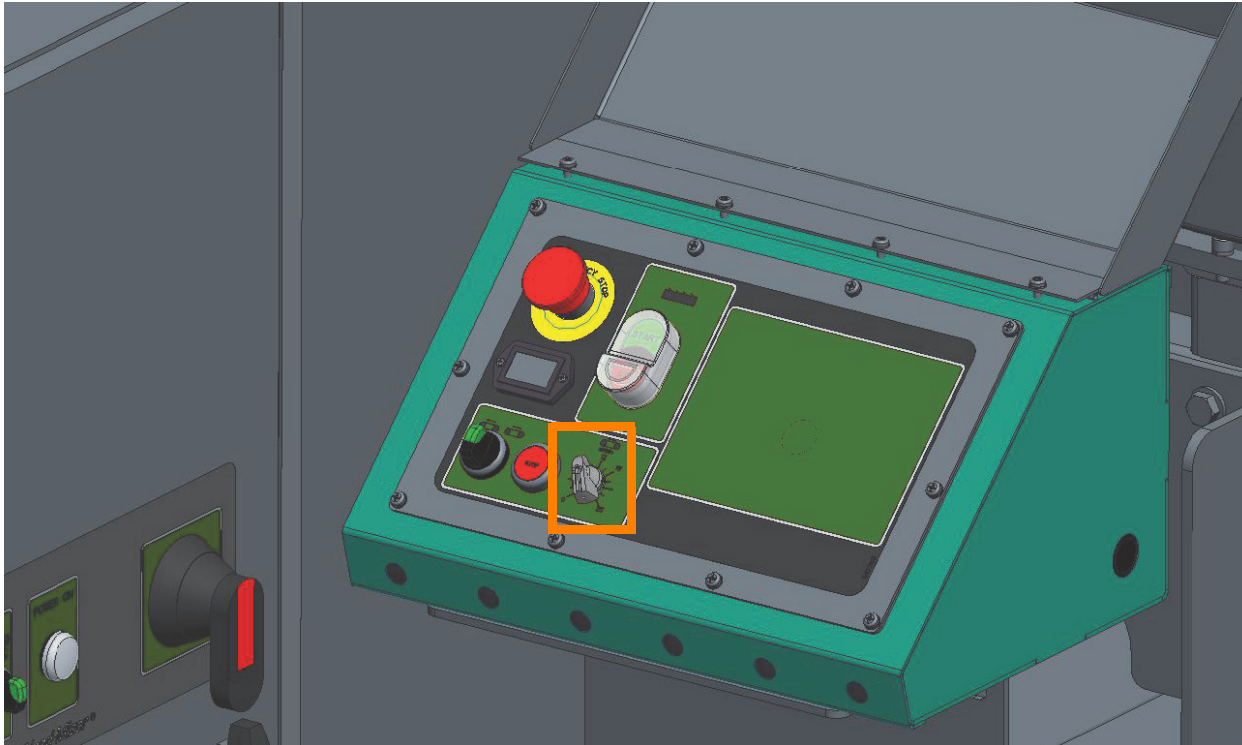

FIG. 2-20

speed switch, located on the control panel, allows the operator to adjust the feed rate from 0 to ca. 20 m (66 ft) per minute.

Turn the switch clockwise to increase the feed rate, counterclockwise to slow the feed rate down.

Factors that will determine what feed rate you can use include:

- Number of saw heads.
- Width of material to be cut. 200mm (7 7/8") wide material will require a slower feed rate than 100mm (3 15/16") wide material.
- Hardness of material to be cut. Some woods that are seasoned or naturally very hard will require slower feed rates.
- Sharpness of blades. Dull or improperly sharpened blades will require slower feed rates than sharp and properly maintained blades.
- Off-bearing capability. Your ability to feed end-to-end will also determine what feed rate you can use.

2.10 Water Lube Operation

Standard Lube System (Supplied from a Water Supply Network)

The Water Lube System keeps the blade clean. It is supplied from a water-pipe network (minimum pressure 0.35bar [0,05MPa], maximum 6bar [0.6MPa]). Water flows through a hose, a solenoid and a manual valve to the blade guide where the blade enters the log. The manual valve located on each saw head controls the amount of water flow.

See Figure 2-21. Connect the water hose to the lube system fitting shown below.

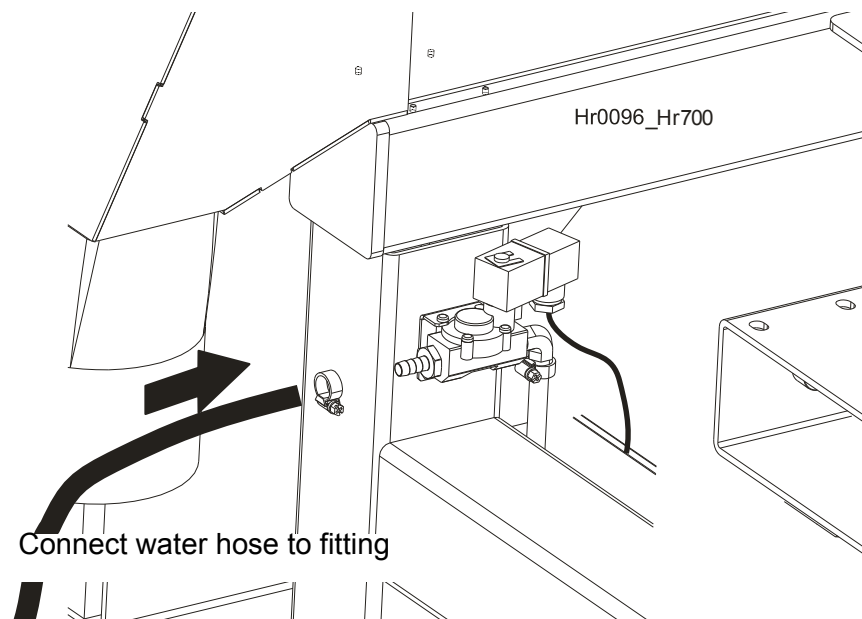

FIG. 2-21

See Figure 2-22. Use the manual valve on each saw head to adjust the amount of water

2 Operation

Standard Lube System (Supplied from a Water Supply Network)

flow.

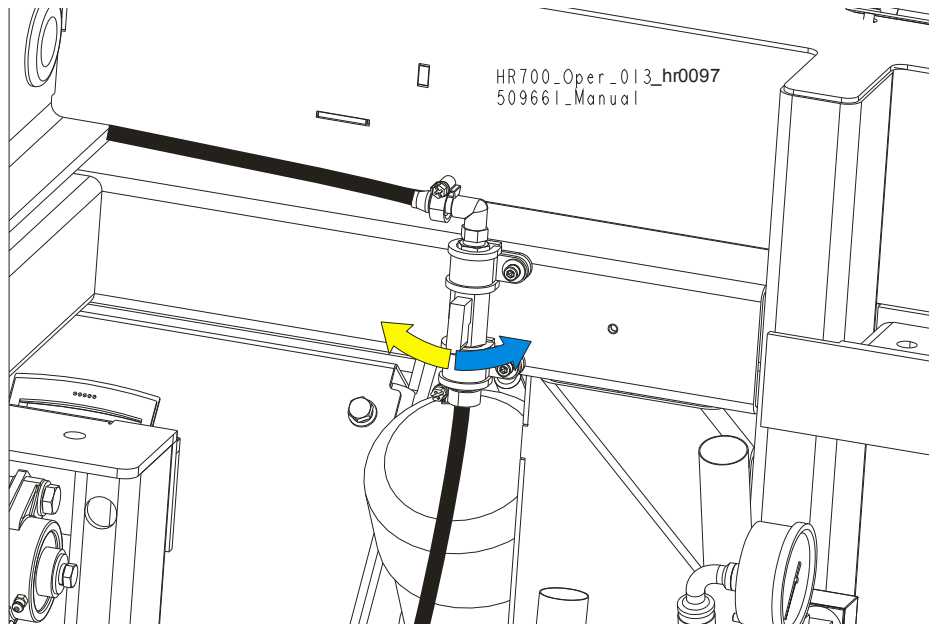

RYS. 2-22

Optional Lube System (Supplied from Water Tanks)

See **Figure 2-23**. The Water Lube System keeps the blade clean. Water flows from a 5-gallon (18.9 liter) bottle through a hose to the blade guide where the blade enters the log. A valve in the bottle cap controls the amount of water flow.

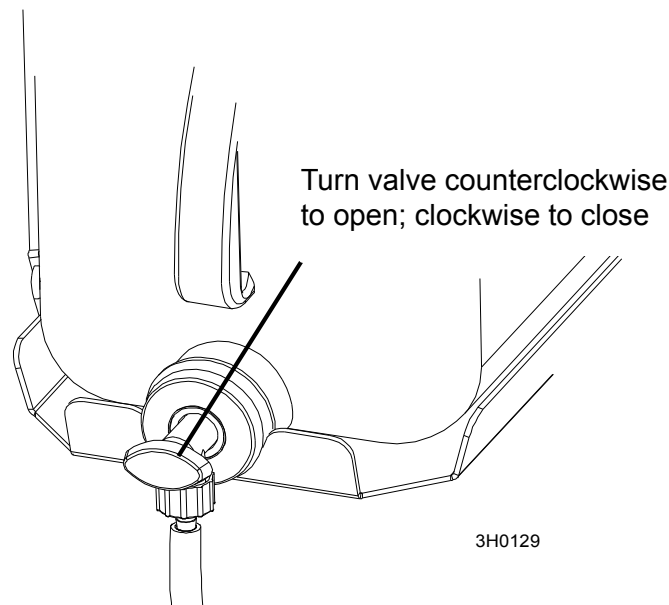

FIG. 2-23

Not all types of wood require the use of the Water Lube System. When it is needed, use just enough water to keep the blade clean. This saves water, and lowers the risk of staining the boards with water. Usual flow will be 1-2 gallons (3.8-7.6 liters) per hour (on average, the bottle content is sufficient for 4-hour-long cutting). A squirt of liquid dishwashing detergent in the water bottle will help clean the blade when cutting wood with a high sap content. Before you start cutting, check the water level in the bottle.



WARNING! Use **ONLY** water with the water lube accessory. Never use flammable fuels or liquids. If these types of liquids are necessary to clean the blade, remove it and clean with a rag. Failure to do so may result in serious injury or death.

Before removing the blade, start the blade motor with the START button. Let the blade spin with water running on it for about 15 seconds. This will clean the blade of sap buildup. Wipe the blade dry with a rag before storing or sharpening.

If you are sawing in freezing temperatures, remove the water lube bottle from the resaw when done sawing and store it in a warm place. Blow any remaining water from the water lube hose.

2.11 Operation Procedure

1. Install a blade if necessary.



WARNING! Always wear gloves and eye protection when handling bandsaw blades. Changing blades is safest when done by one person! Keep all other persons away from area when coiling, carrying or changing a blade. Failure to do so may result in serious injury.

2. Close the blade housing cover.
3. Tension the blade as described in [See Section 2.4.](#)
4. Spin the blade wheel by hand.



WARNING! Use extreme caution when spinning the blade wheel by hand. Make sure your hands are clear of the blade and the wheel spokes before spinning. Failure to do so may result in serious injury.

5. Check alignment of the blade on the blade wheels and blade guides. Adjust as necessary.
6. Raise or lower the saw heads to the desired setting.



DANGER! Make sure all guards and covers are in place and secured before operating the resaw. Failure to do so may result in serious injury.

7. Start the blade motor.
8. Perform pre-start check (rotation direction of the blade motors).
9. Using the feed track speed switch, set the feed rate as desired.



DANGER! Always be sure all persons are out of the path of the blade before starting the motor. Failure to do so will result in serious injury.



WARNING! Always wear eye, ear, respiration and foot protection when operating or servicing your resaw.

10. Place the test material on the feed track and start the feed track.



DANGER! Always be aware of and take proper protective measures against rotating shafts, pulleys, fans, etc. Always stay a safe distance from rotating members and make sure that loose clothing or long hair does not engage rotating members resulting in possible injury.

11. Shut off the blade and feed track. Measure the finished material and adjust the saw heads up or down as necessary. Repeat with the test material until the desired finished dimension is obtained.
12. Restart the blade and feed track.
13. Place material on the infeed table. Return unfinished material to be re-fed into the resaw, i.e. place it on the return table.
14. Monitor the blade tension as the operation continues. Adjust the blade tension if required.
15. If material jam occurs, stop the blade motors and feed track.



WARNING! Allow the blade to come to a complete stop before servicing. Failure to do so will result in serious injury.

16. After the operation is complete, shut off the blade motors and feed track.
17. Release the blade tension if done sawing for the day.



CAUTION! Remove tension from the blade when the resaw is not in use.

2 **Operation** *Operation Procedure*

SECTION 3 MULTISETWORKS OPERATION (OPTIONAL EQUIPMENT)

3.1 General Information

A new Multisetwork has been designed to automatically set the saw heads at any required height. It can be mounted on HR500 and HR700 resaw.

Saw head height is measured continuously and its accuracy depends on condition of the up/down system and feed track.

Multisetwork includes programmable PLC controller, incremental encoder, programmable control panel, motor breakers, frequency converters and limit switches.

3.2 Functions

Multisetwork can work in two modes:

- **MANUAL** – each saw head can be set by the operator separately, kerf is not included.
- **X-BOARD** – the saw heads are set automatically according to pre-selected board thickness values - first saw head is set on the highest calculated height, the last saw head is set on the lowest calculated height. Blade kerf loss is included.
- The values can be displayed in metric or imperial (decimal or fractional) units of measure.
- There are two languages of the menu: Polish and English,
- Diagnostic mode.
- Tuning mode.

3.3 Start-up

After starting the controller, the initial welcome screen will appear:

See Figure 3-1.

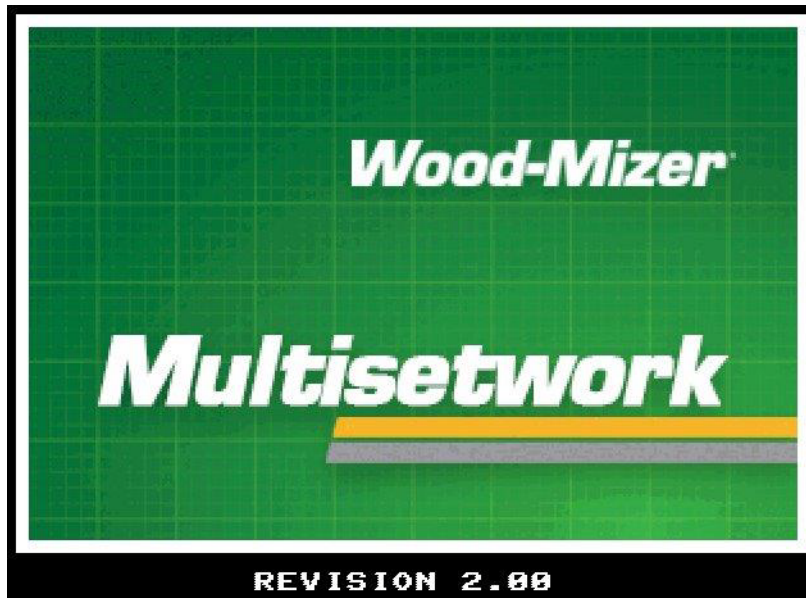

FIG. 3-1

3.3.1 Calibration

After few seconds the CALIBRATION screen is displayed:

See Figure 3-2.

CALIBRATION	
Head 1	Head 2
123 mm	123 mm
Head 3	Head 4
123 mm	123 mm
Head 5	Head 6
123 mm	123 mm
ACCEPT	

FIG. 3-2

Depending on the number of saw heads, the appropriate number of fields to enter values will appear.

Measure the height of each saw head and enter these values in the fields. Then press ACCEPT button. After accepting the entered values, the Choose mode screen will appear:

See Figure 3-3.

CHOOSE MODE
MANUAL
X-BOARD
DIAGNOSTIC

FIG. 3-3

3.4 Manual Mode

After choosing the MANUAL mode in the main window, the screen shown below will be displayed:

See Figure 3-4.

Manual			
HEAD 1		HEAD 2	
REAL	TARGET	REAL	TARGET
123.1 mm	123.1 mm	123.1 mm	123.1 mm
HEAD 3		HEAD 4	
REAL	TARGET	REAL	TARGET
123.1 mm	123.1 mm	123.1 mm	123.1 mm
HEAD 5		HEAD 6	
REAL	TARGET	REAL	TARGET
123.1 mm	123.1 mm	123.1 mm	123.1 mm

BACK << SET >>

FIG. 3-4

On this screen the current blade height value for each saw head and the target height values are displayed.

Press BACK button to move to the main window.

After pressing SET button, all saw heads will be moved to their preset target heights.

To change any target values, press on this value the TARGET window. Next, enter the required height value and confirm by pressing ENTER button.

Additionally saw head heights can be changed manually by operator. To do this, press the REAL window and use arrows to change saw head height with minimal speed:

See Figure 3-5.

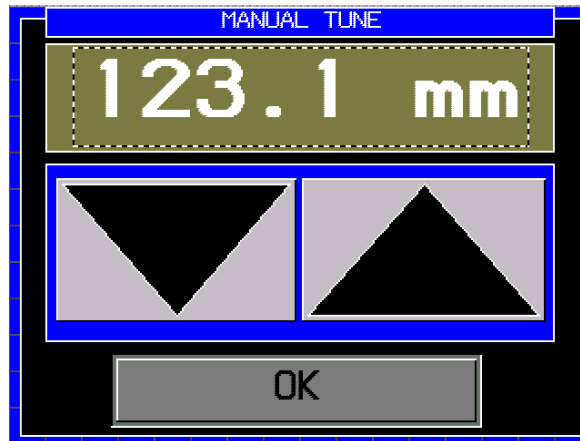

FIG. 3-5

Press OK button to back to MANUAL MODE screen.

Screen with imperial fractional unit of measure is shown below:

See Figure 3-6.

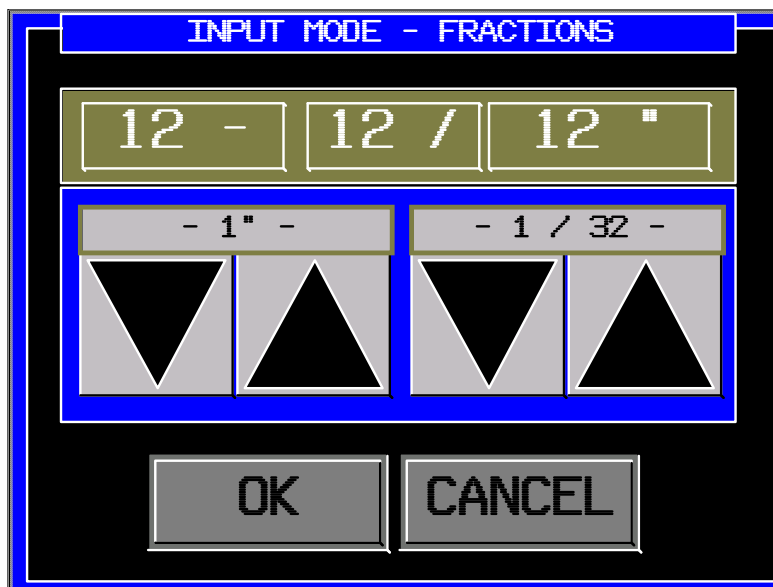

FIG. 3-6

Press OK to confirm entered value.

3

MultiSETWORKS OPERATION (optional equipment)

Manual Mode

When positioning is started, the blinking POSITIONING button will appear instead of SET button.

See Figure 3-7.

Manual			
HEAD 1		HEAD 2	
REAL	TARGET	REAL	TARGET
123 mm	123 mm	123 mm	123 mm
HEAD 3		HEAD 4	
REAL	TARGET	REAL	TARGET
123 mm	123 mm	123 mm	123 mm
HEAD 5		HEAD 6	
REAL	TARGET	REAL	TARGET
123 mm	123 mm	123 mm	123 mm

BACK **POSITIONING**

FIG. 3-7

3.5 X-Board Mode

It is necessary to set the correct kerf value to allow the X-Board mode to work properly. Kerf value can be set in Diagnostic menu ([See Section 3.6.3](#)).

See Figure 3-8.

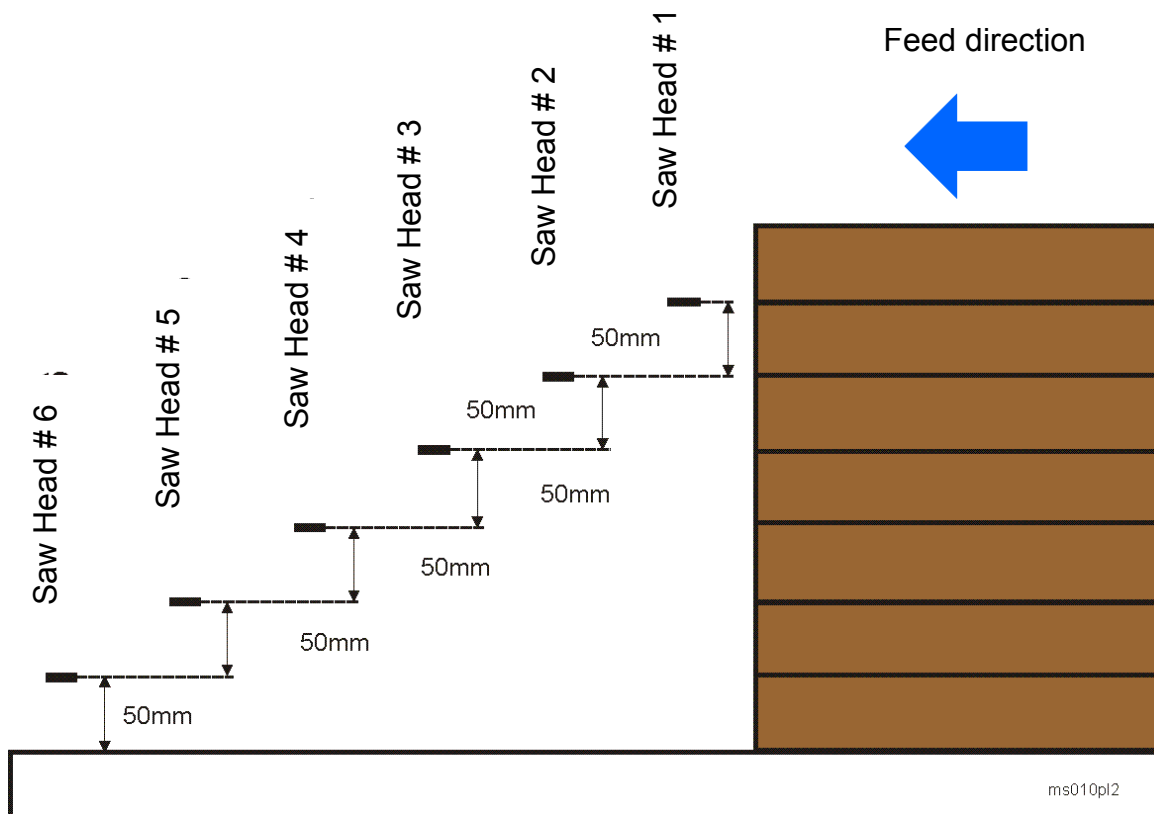

FIG. 3-8

After choosing the X-Board menu, depending on chosen units of measure, the following screen will be displayed:

See Figure 3-9.

X-BOARD			
BOARD 1	50 mm	310 mm	HEAD 1
BOARD 2	50 mm	258 mm	HEAD 2
BOARD 3	50 mm	206 mm	HEAD 3
BOARD 4	50 mm	154 mm	HEAD 4
BOARD 5	50 mm	102 mm	HEAD 5
BOARD 6	50 mm	50 mm	HEAD 6

BACK POSITIONING

FIG. 3-9

The X-Board screen includes a list of all saw head heights and board thickness values preset for each saw head.

To move to the main window (Choose Mode screen), press the BACK button.

After pressing SET button, each saw head will automatically be set at the calculated height.

To change any board thickness value, press on this value, enter the desired value and press ENTER. The entered board thickness value will automatically be copied to all dimensions above this value.

If the imperial fractional unit of measure was selected, the screen shown below will appear:

See Figure 3-10.

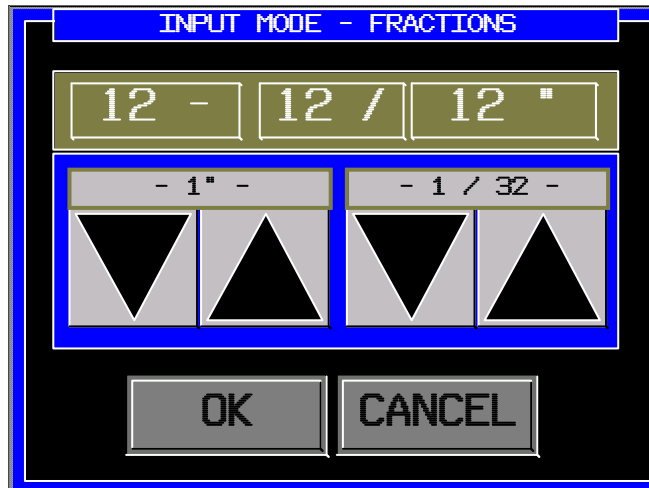

FIG. 3-10

In this case, press OK button to confirm the entered value.

When positioning is started, the blinking POSITIONING button will appear instead of SET button.

First saw head is set at the highest calculated height, last active saw head is set on the lowest calculated height.

As it is in Manual Mode, saw head heights can be changed manually by the operator. To do this, press the REAL window and use arrows to change saw head height with minimal speed:

See Figure 3-11.

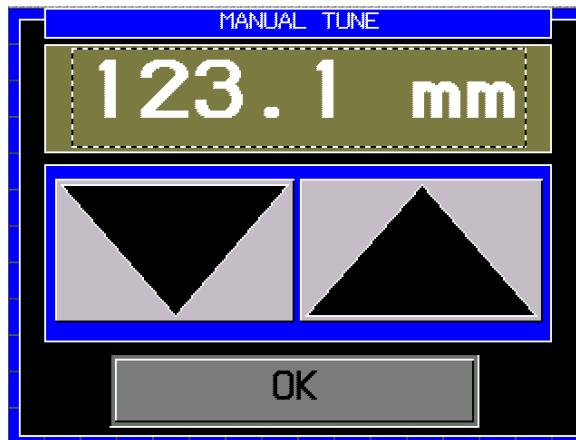

FIG. 3-11

When saw heads are set, press OK button to move to X-Board mode screen.

3.6 Diagnostic

Press DIAGNOSTIC button on the Choose mode screen:

See Figure 3-12.

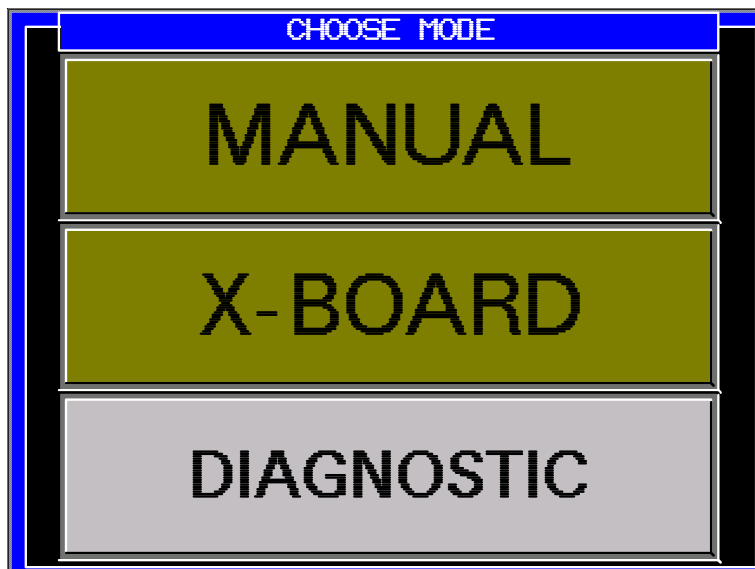

FIG. 3-12

The following screen will be displayed:

See Figure 3-13.



FIG. 3-13

Units of measure and language can be set on the DIAGNOSTIC screen. Also controller calibration can be made by pressing calibration button.

3.6.2 Calibration

After pressing CALIBRATION button, following screen will be displayed.

See Figure 3-14.



FIG. 3-14

Check, if values of each saw head height are the same with real saw heads height read on the scale located on each saw head mast. If any of these values is incorrect, press this value, enter the correct value and confirm.

3.6.3 Diagnostic I/O

After pressing DIAGNOSTIC I/O button, the following screen will be displayed:

See Figure 3-15.

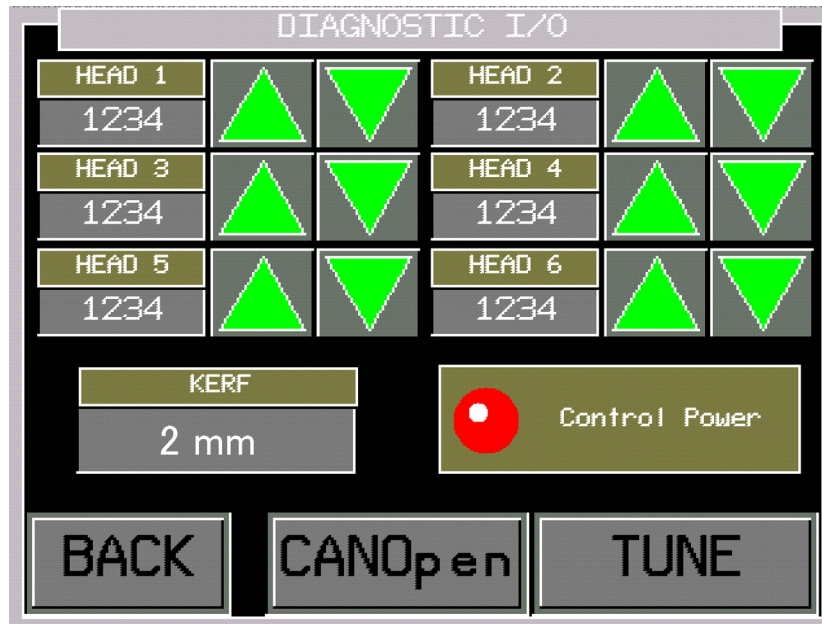

FIG. 3-15

The values in each HEAD window represent the current numbers of encoder revolutions. Use arrows to manually control the up/down system.

- Kerf. Press KERF window to enter the kerf value. Next confirm by pressing ENTER button. The correct kerf value for Wood-Mizer blades is 2.
- Control Power LED, shows the condition of the machine main control circuit.
- CANOpen button is used to move to CAN diagnostic screen:

See Figure 3-16.

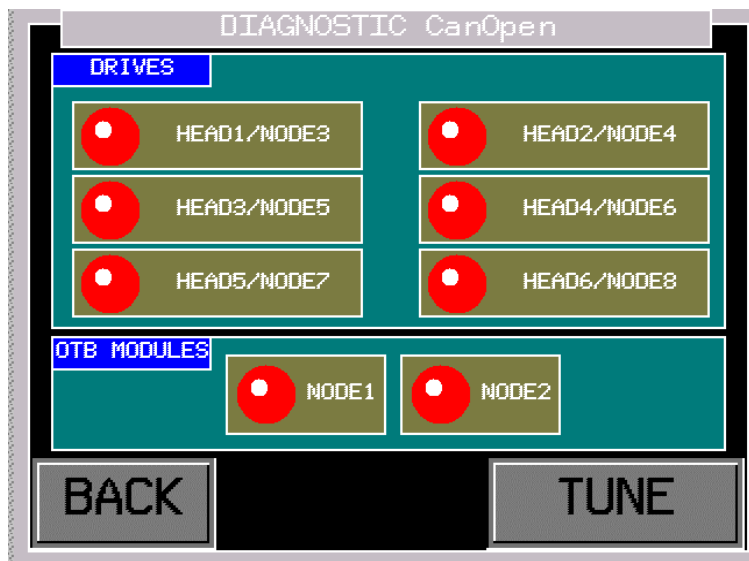

FIG. 3-16

In the DRIVES section, LEDs show the communication status with each drive. Green - communication is ok, Red - there is no communication.

OTB Modules show the communication status with OTB modules. These modules are active only when machine is equipped with 3, 4, 5 or 6 saw heads. When there is only one or two saw heads, control lights will be red - there will be no communication with OTB modules.

Press the window with saw head number/mode to move to the extended drive status. The following window will appear:

See Figure 3-17. Drives values may vary.

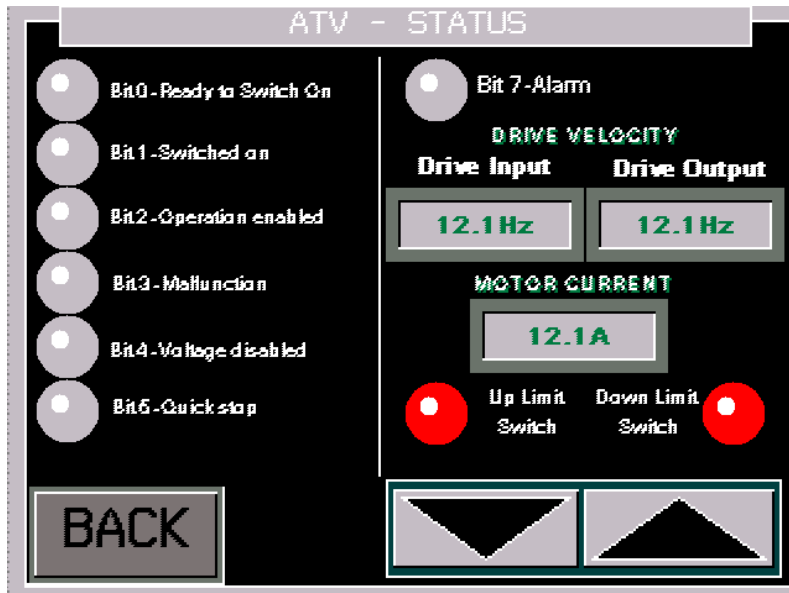

FIG. 3-17

Point Bit0-Bit7 – drive register status

Drive velocity – Input – Entered speed (Hz).

Drive velocity – Output – Motor speed (Hz).

Motor current – nominal value for 400/460V should be ~ 1,5A.

Up and down limit switches – conditions of up and down limit switches.

Green – limit switch is released, Red – limit switch is active.

Use arrows to move the saw head up and down with minimal speed.

3.6.4 Tuning

Caution! – All changes have to be agreed with Wood-Mizer Customer Service! These parameters influence up/down operation.

If there are problems with saw head positioning, change parameters. These changes influence saw head movement.

Choose Tuning on the DIAGNOSTIC/TUNE menu:

See Figure 3-18.



FIG. 3-18

The screen below will appear:

See Figure 3-19. Values displayed by the controller may vary.

TUNE	
MIN DISTANCE - DOWN	MIN DISTANCE - UP
12 pulses	12 pulses
MIN FREQUENCY - DOWN	MIN FREQUENCY - UP
12.1 Hz	12.1 Hz
MAX DISTANCE - DOWN	MAX DISTANCE - UP
123 pulses	123 pulses
MAX FREQUENCY - DOWN	MAX FREQUENCY - UP
12.1 Hz	12.1 Hz
JOG FREQUENCY	TOLERANCE
1.1 Hz	1 pulses
BACK	Back to default values

FIG. 3-19

3.7 Errors

- After choosing the X-BOARD mode, the following message may occur:

See Figure 3-20.



FIG. 3-20

Enter the DIAGNOSTIC I/O mode. Check if number of saw heads displayed on the screen and mounted on the machine are the same:

See Figure 3-21.

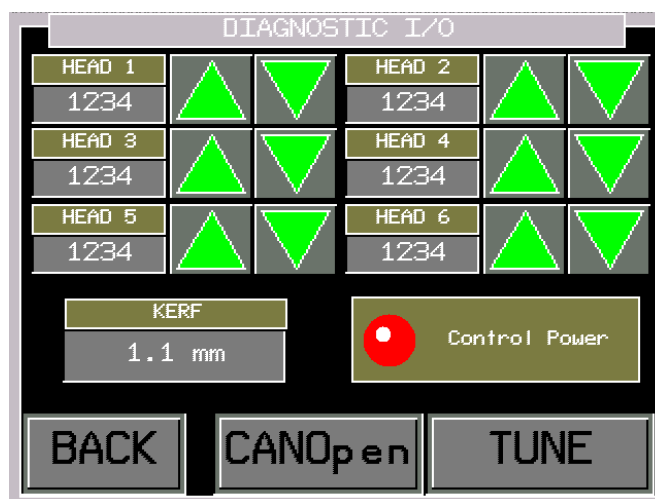

FIG. 3-21

When one saw head (e.g. saw head no 3) is missing, the diagnostic screen looks like shown below:

See Figure 3-22.

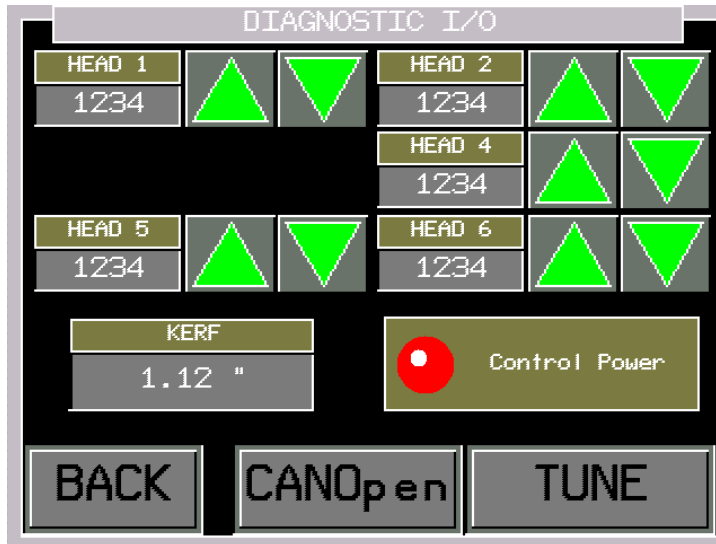

FIG. 3-22

Make sure if COF error is displayed on the drive controller after opening electric box.

CAN_R LED should be steady on, I/O and CAN_E LED should blinks red:

See Figure 3-23.

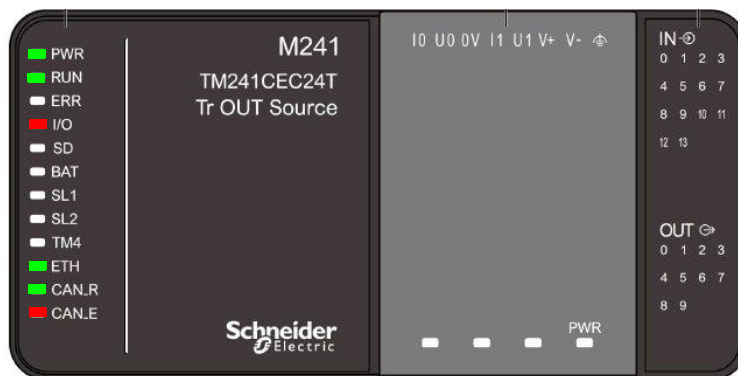

FIG. 3-23

If so, check connection between drive and cantap (patchcord with RJ45 terminals). When two or more saw heads are missing, check connection between cantaps and PLC controller. Next turn off and turn on the power to restart the connection. Connection condition can be also check on the Diagnostic screen by

pushing CanOpen button:

See Figure 3-24.

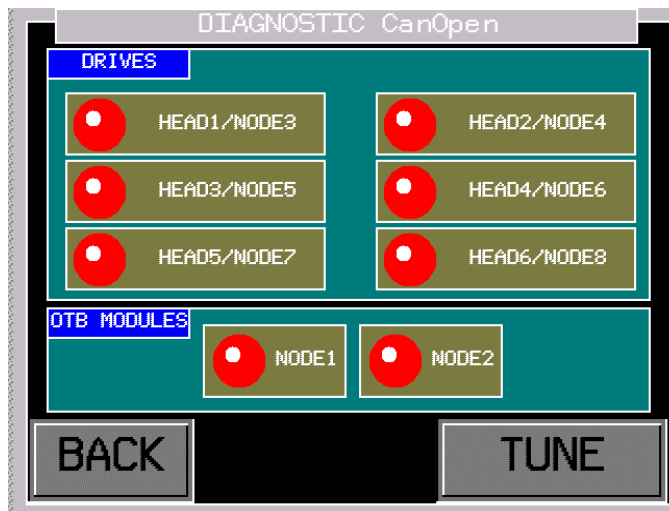

FIG. 3-24

In the DRIVES section, LEDs show the communication status with each drive. Green - communication is ok, Red - no communication.

OTB Modules show the communication status with OTB modules. These modules are active only when machine is equipped with 3, 4, 5 or 6 saw heads. When there is only one or two saw heads, control lights will be red - there will be no communication with OTB modules. If there is no connection between controller and OTB module(s), on the OTB module ERR LED will turn on:

See Figure 3-25.

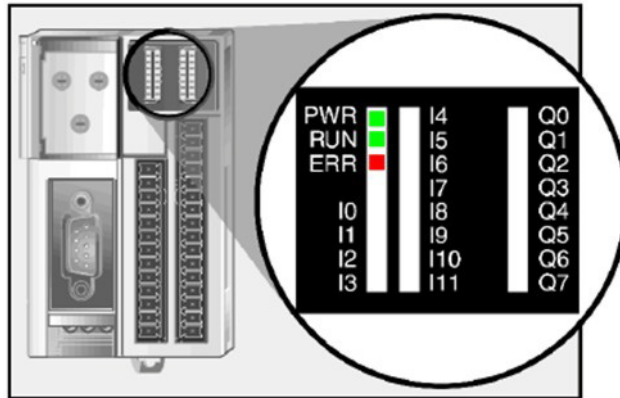

FIG. 3-25

3.7.5 Impulses are not counted.

See Figure 3-26.



FIG. 3-26

This error may be caused by damage of: encoder, clutch between encoder and motoreducer, wire connecting encoder and connectors or wires connecting PLC controller inputs and power supply with connectors.

First remove encoder cover and check if encoder clutch is tightened and is not damaged.

Next, check the encoder connection to PLC controller or OTB module (encoders of the saw head number 1 and 2 are connecting with PLC 1.0 controller; encoders of the saw head number 3 and 4 are

connecting with PLC 2.0 controller; encoders of the saw head number 5 and 6 are connecting with PLC 3.0 controller).

Controller/Module	Encoder/Saw Head	Inputs
PLC 1.0	Encoder 1/Saw Head 1	I0 and I1
PLC 1.0	Encoder 2/Saw Head 2	I4 and I5
PLC 2.0	Encoder 3/Saw Head 3	I0 and I1
PLC 2.0	Encoder 4/Saw Head 4	I6 and I7
PLC 3.0	Encoder 5/Saw Head 5	I0 and I1
PLC 3.0	Encoder 6/Saw Head 6	I6 and I7

TABLE. 3-1

Next choose the Diagnostic Mode:

See Figure 3-27.

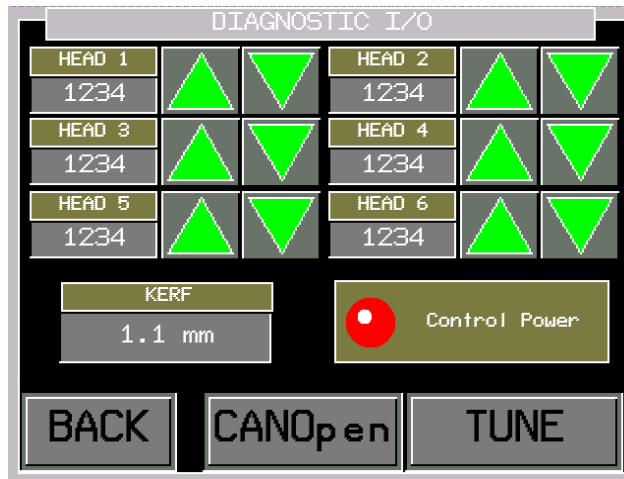

FIG. 3-27

Use arrow buttons to move the saw head up or down and watch LED of the encoder input.

See Figure 3-28.

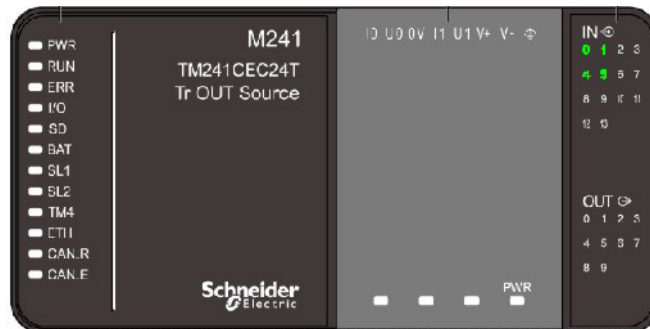

FIG. 3-28

See Figure 3-29.

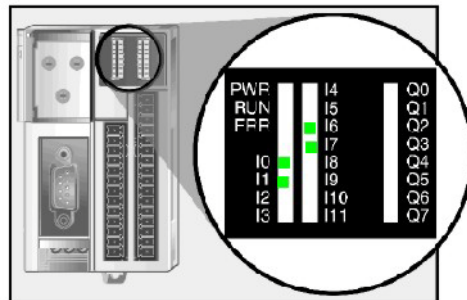

FIG. 3-29

LED should blink during the saw head movement. If LEDs of the encoder don't blink or only one of them blinks, check encoder power supply and damage of the connecting wires.

Voltage on the connectors between brown and blue wire should be ~24VDC.

3.7.6 Incorrect up/down movement direction

See Figure 3-30.



FIG. 3-30

This error may be caused by improper connection of the encoder or up/down motor. Enter the Diagnostic mode. Check if saw head is moving up when you press the UP arrow button and down when you press the DOWN arrow button.

If not, invert the phases on the motor or on the up/down motor contactors.

If the saw head movement is still incorrect, change places of the wires on the PLC controller (or PLC

module) input - black and white wires.

3.7.7 Limit switches

See Figure 3-31.

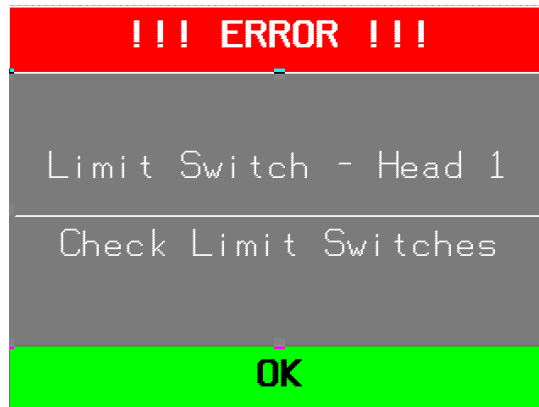

FIG. 3-31

Possible error cause:

- Saw head run on the up/down limit switch
- limit switch or wire between limit switch and connector is damaged
- wire between connector and inputs LI4 or LI5 of the drive are damaged.

When saw head run on the limit switch, it can move in the opposite direction.

Status of the limit switch can be checked on the Diagnostic screen for CanOpen devices.

See Figure 3-32.

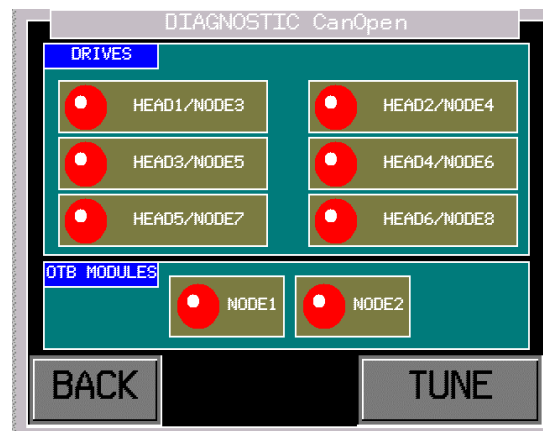

FIG. 3-7

Press the window with saw head number/mode to move to the extended drive status. The following window will appear:

See Figure 3-33.

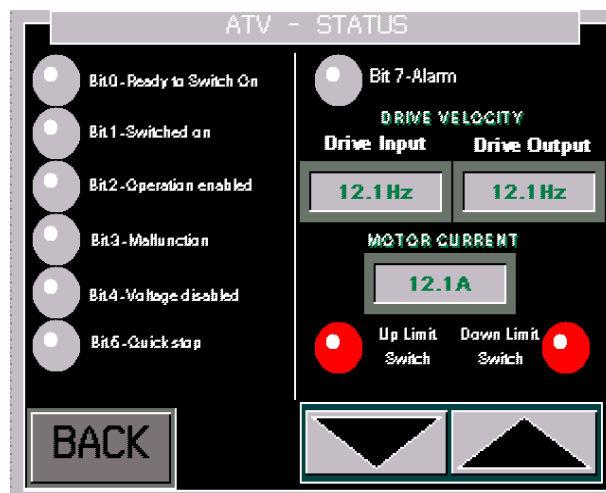

FIG. 3-8

Upper and lower limit switches – conditions of the upper and lower limit switches.

Green – limit switch is released, Red – limit switch on (is active)

If the saw head is not on the limit switch and limit switch LED is on, check the limit switch and next check connections between limit switch and drive.

3.7.8 Positioning error

See Figure 3-34.



FIG. 3-9

Saw head run too slow or too far.

It is connected with saw head movement parameters on the TUNING screen:

See Figure 3-35.

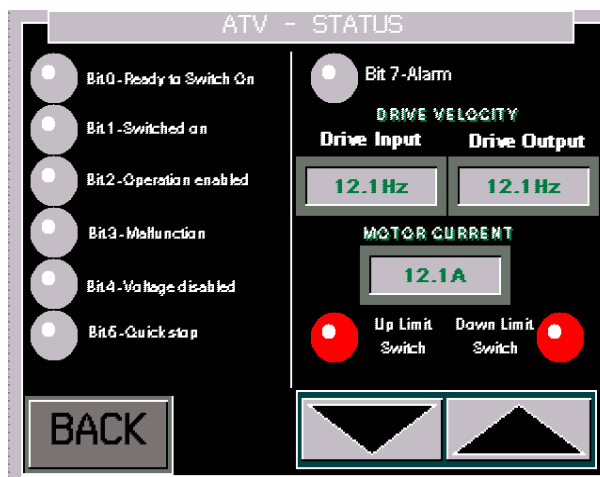

FIG. 3-10

First push Powrót do ustawień domyślnych button, to set the fabric positioning parameters.

If error occurs once more, please contact with Wood-Mizer Customer Service.

Caution! – All changes have to be agreed with Wood-Mizer Customer Service! These parameters influence up/down operation.

SECTION 4 MAINTENANCE

This section lists the maintenance procedures that need to be performed.



WARNING! Disconnect and lock out power supply before servicing, cleaning and doing maintenance to the saw! Failure to do so may result in serious injury.



This symbol identifies the interval (hours of operation) at which each maintenance procedure should be performed.

Be sure to refer to the motor manual for maintenance procedures concerning the blade motor.

4.1 Wear Life

See Table 4-1. This chart lists estimated life expectancy of common replacement parts if proper maintenance and operation procedures are followed. Due to the many variables which exist during resaw operation, actual part life may vary significantly. This information is provided so that you may plan ahead in ordering replacement parts.

Part Description	Estimated Life
B57 Blade Wheel Belts	500 hours
Blade Guide Rollers	1000 hours
Drive Belt	1250 hours

TABLE 4-1

4.2 Blade Guides

1. Check the rollers for performance and wear every blade change. Make sure the rollers are clean and spinning freely. If not, rebuild them. Replace any rollers which have worn smooth or have become cone shaped. See the Parts manual for blade guide rebuild kits and complete roller assemblies.

4.3 Sawdust Removal

1. Remove the excess sawdust from the blade wheel housing and sawdust chute every blade change.

4.4 Vertical Mast



Clean the vertical mast angles, wipe them dry and lubricate with a WD40 oil every 50 hours of operation.



CAUTION! Never use grease on the mast angles as it will collect sawdust.

4.5 Miscellaneous Lubrication

1. Apply a thin film of a lithium grease to the blade guide arm to help prevent it from rusting.
50
2. Lubricate the feed track chain with an easily penetrating oil such as WD-40.
50



CAUTION! Never apply grease to the feed track chain. It causes sawdust buildup in chain links.

3. Make sure all safety warning decals are readable. Remove sawdust and dirt. Replace any damaged or unreadable decals immediately. Order decals from your Customer Service Representative.
4. Lubricate the acme screws (screws for saw head tilting and raising or lowering) with a lithium grease every 50 hours of operation.
50

4.6 Belts

1. Check the blade wheel belts for wear every 50 hours of operation. Replace as needed.
50
2. Periodically check all belts for wear. Replace any damaged or worn belts as needed.

4

MAINTENANCE

Drive Belt Adjustment

4.7 Drive Belt Adjustment



WARNING! Do not for any reason adjust the drive belt with the motor running. Doing so may result in serious injury.

50

See Table 4-2. Check the drive belt tension after the first 4 hours, and every 50 hours thereafter. See the table below for drive belt tension specifications for your resaw.

Motor	Belt Tension
E11, E15	11 mm (7/16") deflection with 16 lbs. (7.2 KG) of deflection force
E20, E25	20mm (25/32") deflection with 16,5 lbs. (7.5 KG) of deflection force

TABLE 4-2

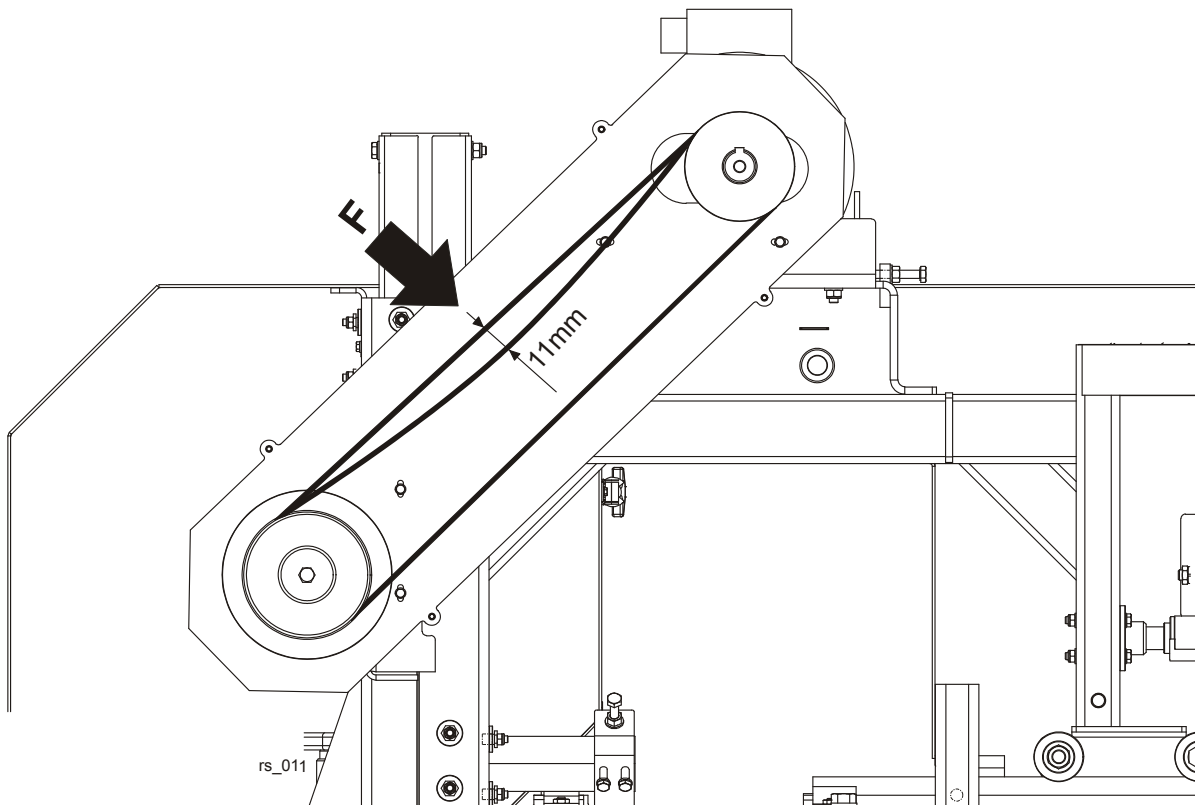

FIG. 4-1

To adjust the drive belt tension:

1. Remove the drive belt guard.
2. Loosen the four motor mounting bolts (see Figure 4-2).

3. Loosen one of the adjustment bolts, shown in Figure 4-2, and turn the other until the belt has proper deflection. (To increase the belt tension, you must loosen the right bolt and appropriately turn the left one.) **NOTE:** Be sure to adjust the bolts evenly so the motor remains in alignment.
4. Tighten the four motor mounting bolts.

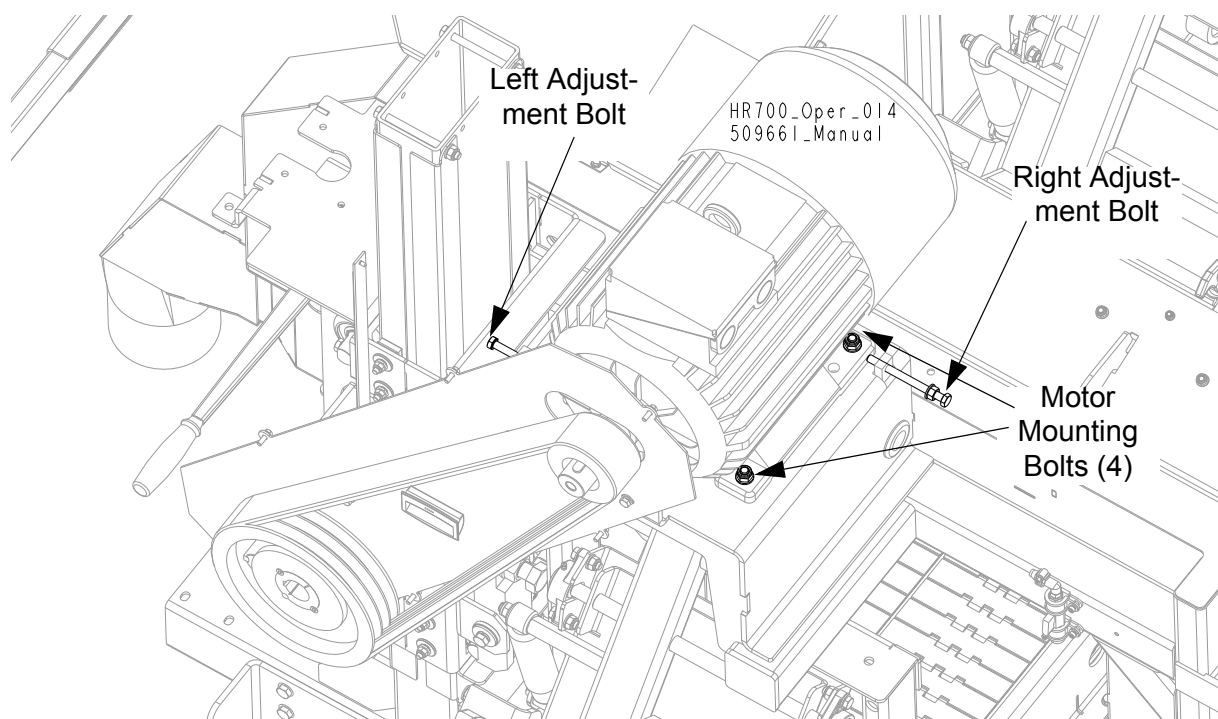

FIG. 4-2



Periodically check the belt for wear. Replace if damaged or worn.

See Figure 4-3. Keep the motor and drive pulleys aligned to prevent premature belt wear. To align the motor pulley to the drive pulley, loosen the set screw in the motor pulley groove and slide the motor pulley on the shaft until it is in line with the drive pulley.

4 MAINTENANCE

Drive Belt Adjustment

After performing the alignment, make sure the drive belt tension has not been changed.

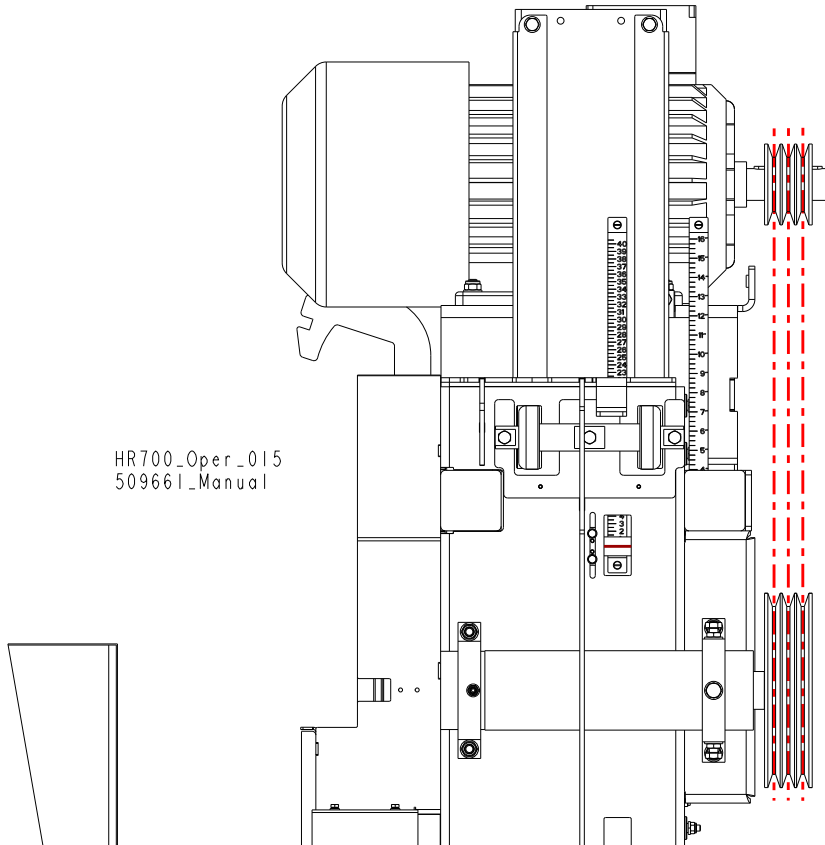

FIG. 4-4

4.8 Feed Track Chain Tension

See **Figure 4-5**. If necessary, use the adjustment bolts shown below to adjust the feed track chain tension. **NOTE:** The bolts must be adjusted evenly.

See **Figure 4-6**.

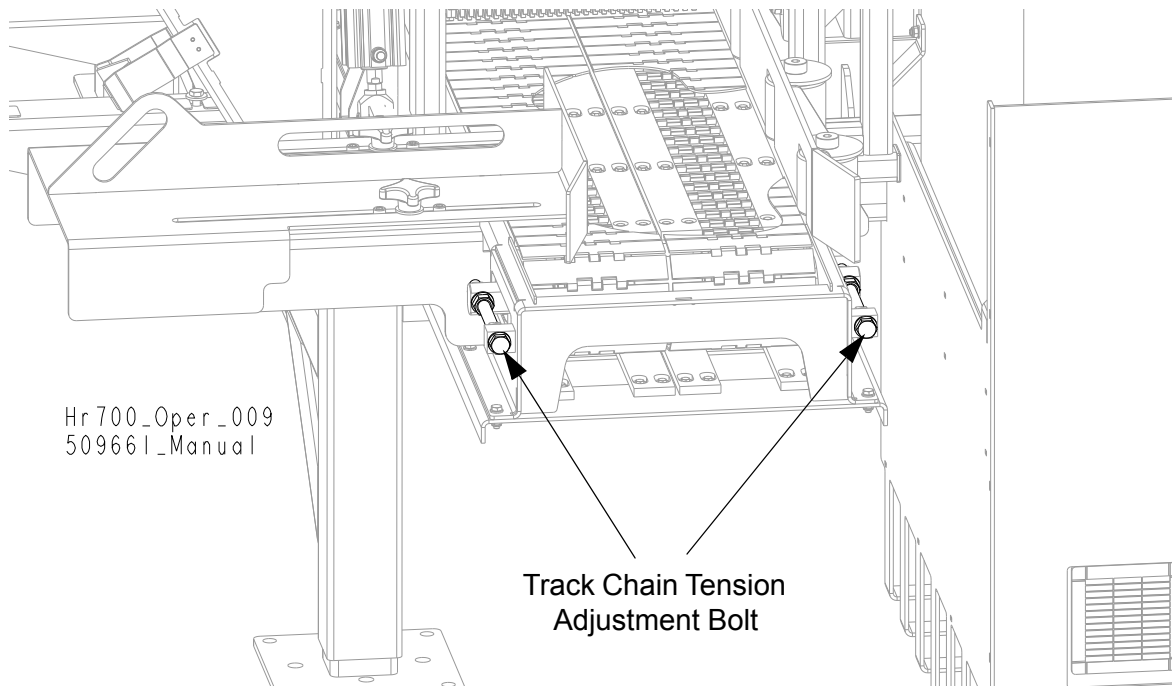

FIG. 4-7

4.9 Up/Down System

1. Lubricate the acme screw, shown below, with a lithium grease every fifty hours of operation, but at least once a week.

50

See Figure 4-8.

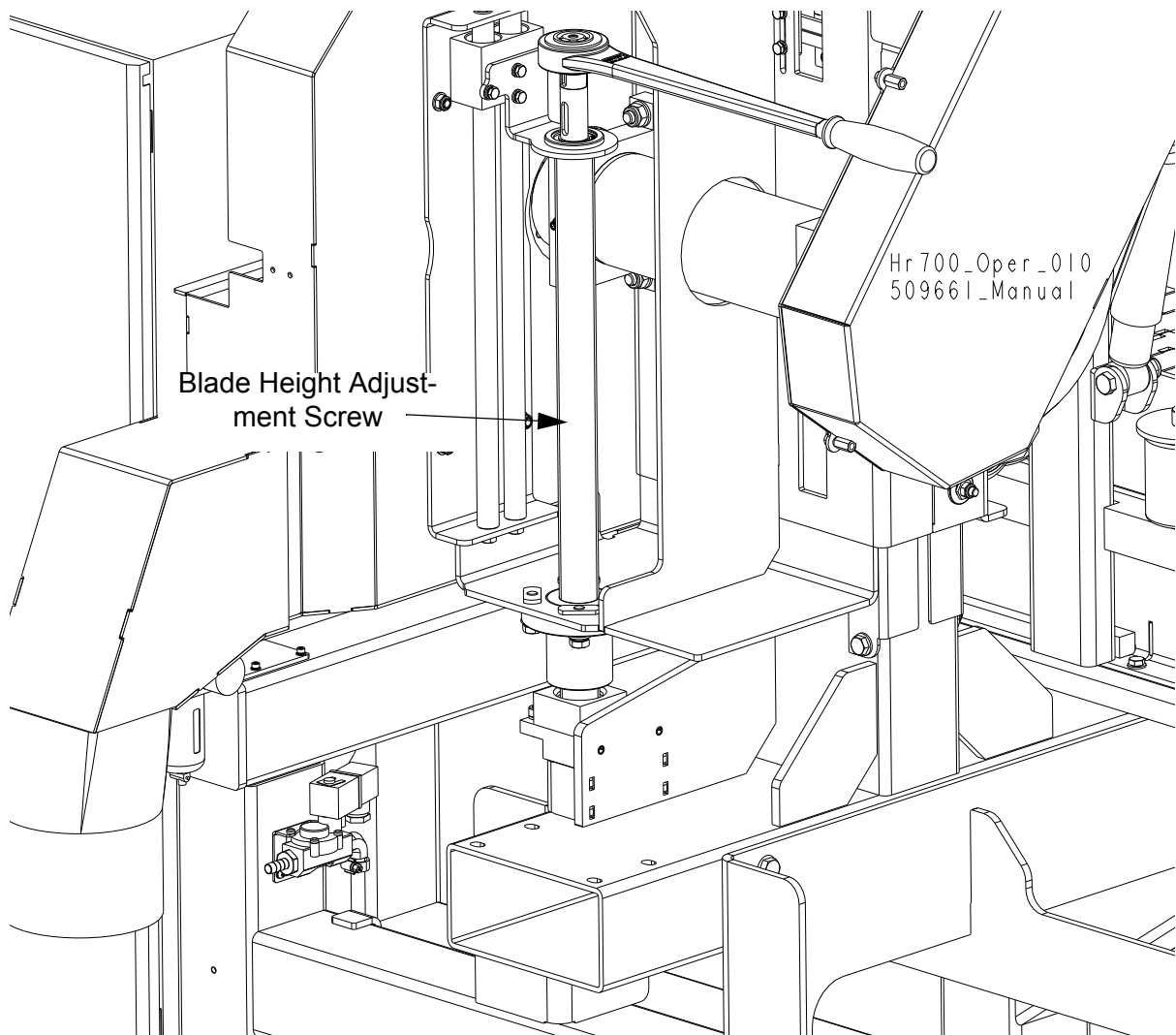

FIG. 4-9

4.10 Long-Term Storage

If the machine is not used for a long period of time, do as follows:

- Disconnect the power cord.

-
- Perform all routine actions described above.
 - Remove the blades and store them well lubricated in above zero temperature.
 - Loosen the motor belt tension.
 - Spray a thin layer of anti-rust coating (such as P.D.R.P) onto the places not protected against rusting.
 - Store the machine in a well ventilated room.

4.11 End of the life cycle

As a responsible manufacturer we care about the environment. As such we urge you to follow the correct disposal procedure for your product and packaging materials. This will help conserve natural resources and ensure that it is recycled in a manner that protects health and the environment. You must dispose of this product and its packaging according to local laws and regulations. Because this product contains electronic components and mineral oil, the product and its accessories must be disposed of separately from household waste when the product reaches its end of life.

Contact your local authority to learn about disposal and recycling. The product and packaging should be taken to your local collection point for recycling

4.12 Safety Devices Inspection

HR Safety Devices Inspection

Before beginning a shift, the following safety devices of the HR resaw should always be checked:

- E-STOP button circuit - control box
- E-STOP button circuit - fence
- Safety switch circuit - 1-6 saw heads
- Motor brake and its circuit

1. Control box and main electric box E-STOP circuit inspection

- Start the main motor;
- Push the E-STOP button located on the control box. The motor should stop. It should not be possible to restart the motor until the E-STOP is released.
- Push the E-STOP button located on the main control box. The motor should stop. It should not be possible to restart the motor until the E-STOP is released.

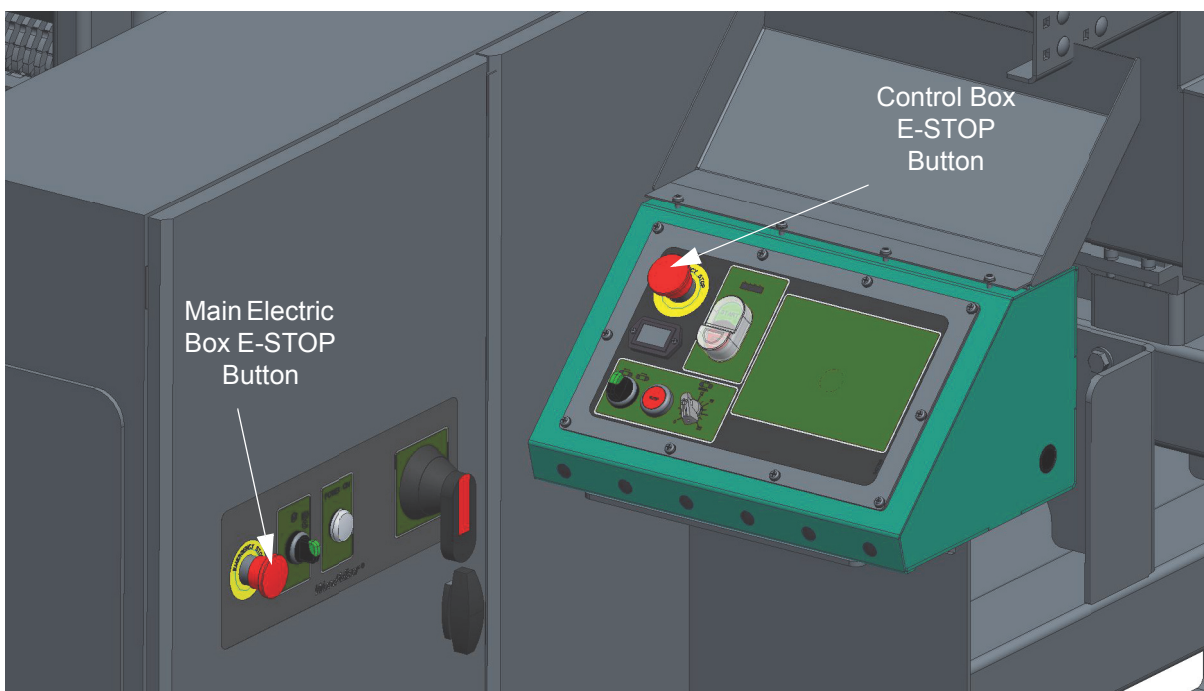

FIG. 4-10

2. Fence E-STOP circuit inspection

- Start the main motor;
- Push the E-STOP button located on the fence at the back of the machine. The motor should stop. It should not be possible to restart the motor until the E-STOP is released.

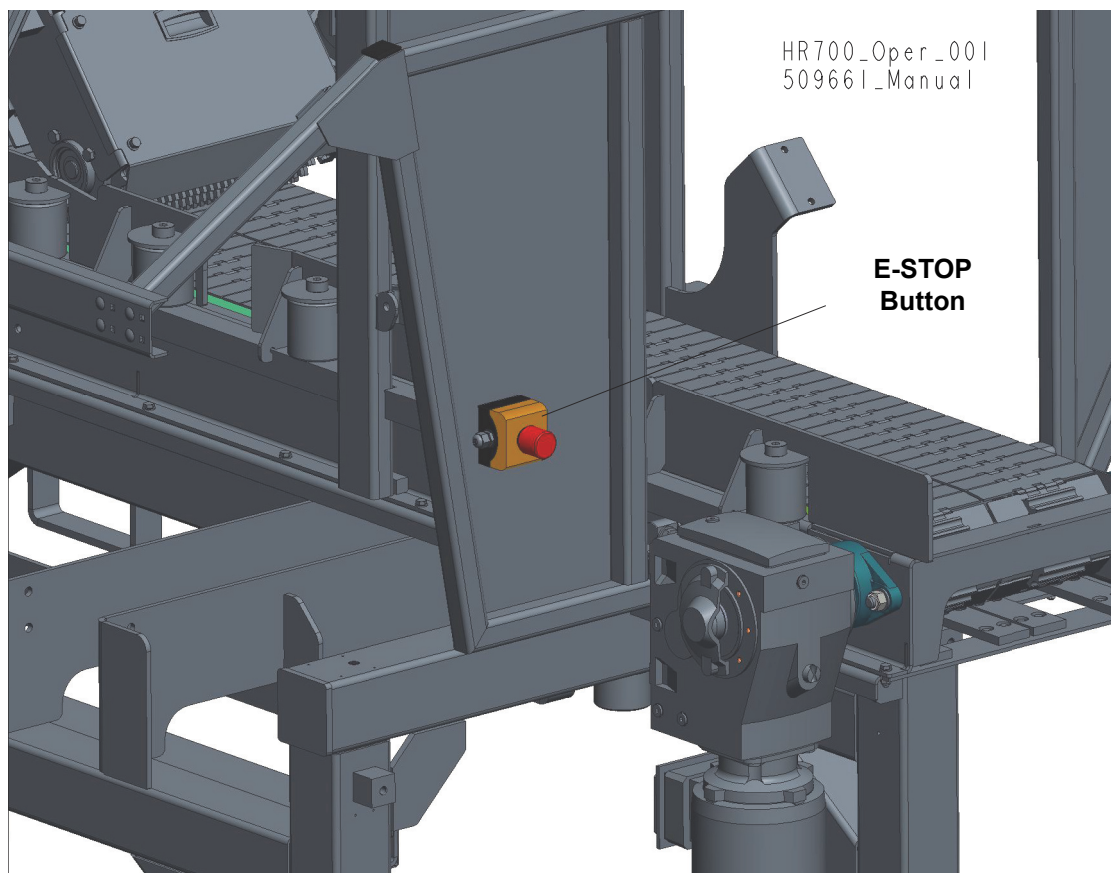

FIG. 4-11

3. Safety switch circuit inspection - 1 - 6 saw heads

- Start the main motors;
- Open the blade housing cover No.1;
- The main motor of the saw head No.1 should stop;
- Try to start the motor of the saw head No.1 using the START button. The motor cannot be started.

4

MAINTENANCE

Safety Devices Inspection

- Close the blade housing cover No.1;
- The motor should remain turned off.
- Repeat the above steps for all remaining saw heads.

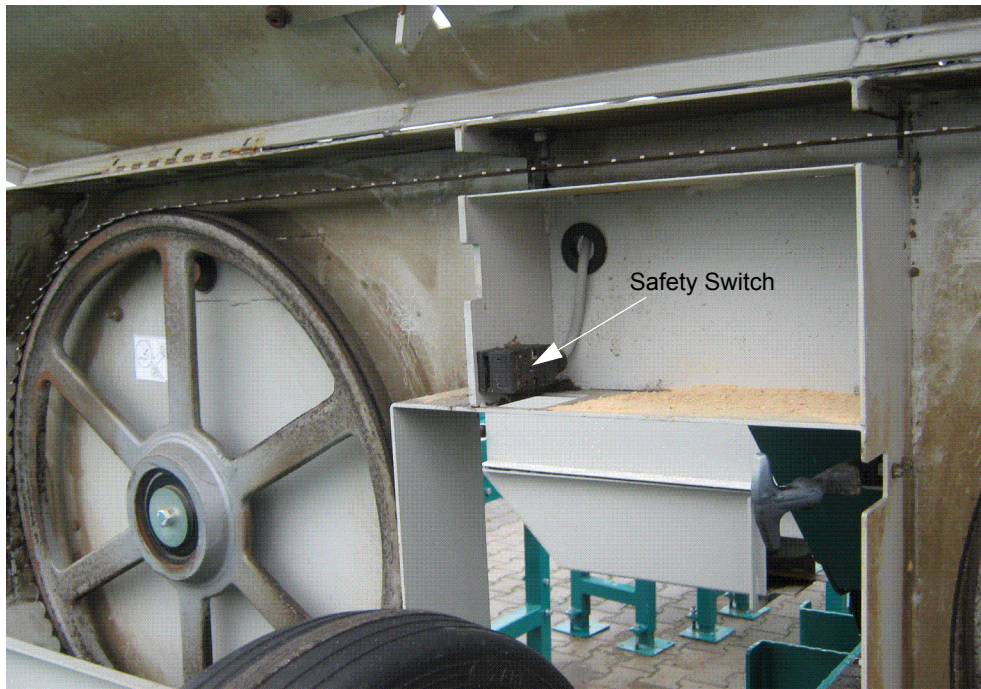

FIG. 4-12

6. Main motor brakes and their circuits

- Start the main motor of the saw head No.1. Then stop the motor by pushing the STOP button. Measure the braking time.
- Start the main motor of the saw head No.1. Then turn the key switch to the "0" position to stop the motor. Measure the braking time.
- Start the main motor of the saw head No.1. Then stop the motor by turning the key switch to the "H" position. Measure the braking time.
- Repeat the above steps for all remaining saw heads.

The motor braking time should be shorter than 10 seconds. If it is longer, adjust or replace the brake linings. (See the motor manual.)

SECTION 5 ALIGNMENT

5.1 Alignment Procedures

The Wood-Mizer resaw is factory aligned. This section includes instructions on how to realign the resaw completely. Be scrupulous when performing all alignment steps as resaw alignment determines the accuracy of your cuts. The alignment procedure should be performed approximately every 1500 hours of operation.

Routine Alignment Procedure:

1. Install and track the blade ([See Section 5.2](#)).
2. Check and adjust the vertical alignment of the blade guide arm ([See Section 5.5](#)).
3. Check and adjust the horizontal alignment of the blade guide arm ([See Section 4.6](#)).
4. Check and adjust the vertical angle of the blade guides ([See Section 5.9](#)).
5. Check and adjust the horizontal angle of the blade guides ([See Section 4.11](#)).
6. Check and adjust the spacing between the blade guide flanges and the back of the blade ([See Section 5.10](#)).
7. Check that the blade height scale accurately displays the actual distance from the bottom of the blade to the feed track and adjust if necessary ([See Section 4.13](#)).

Complete Alignment Procedure:

Perform all steps in this section to completely realign the resaw.

5.2 Blade Installation And Tracking

See Figure 5-1. Install a blade and apply the proper tension as shown below. [See Section 2.4](#)

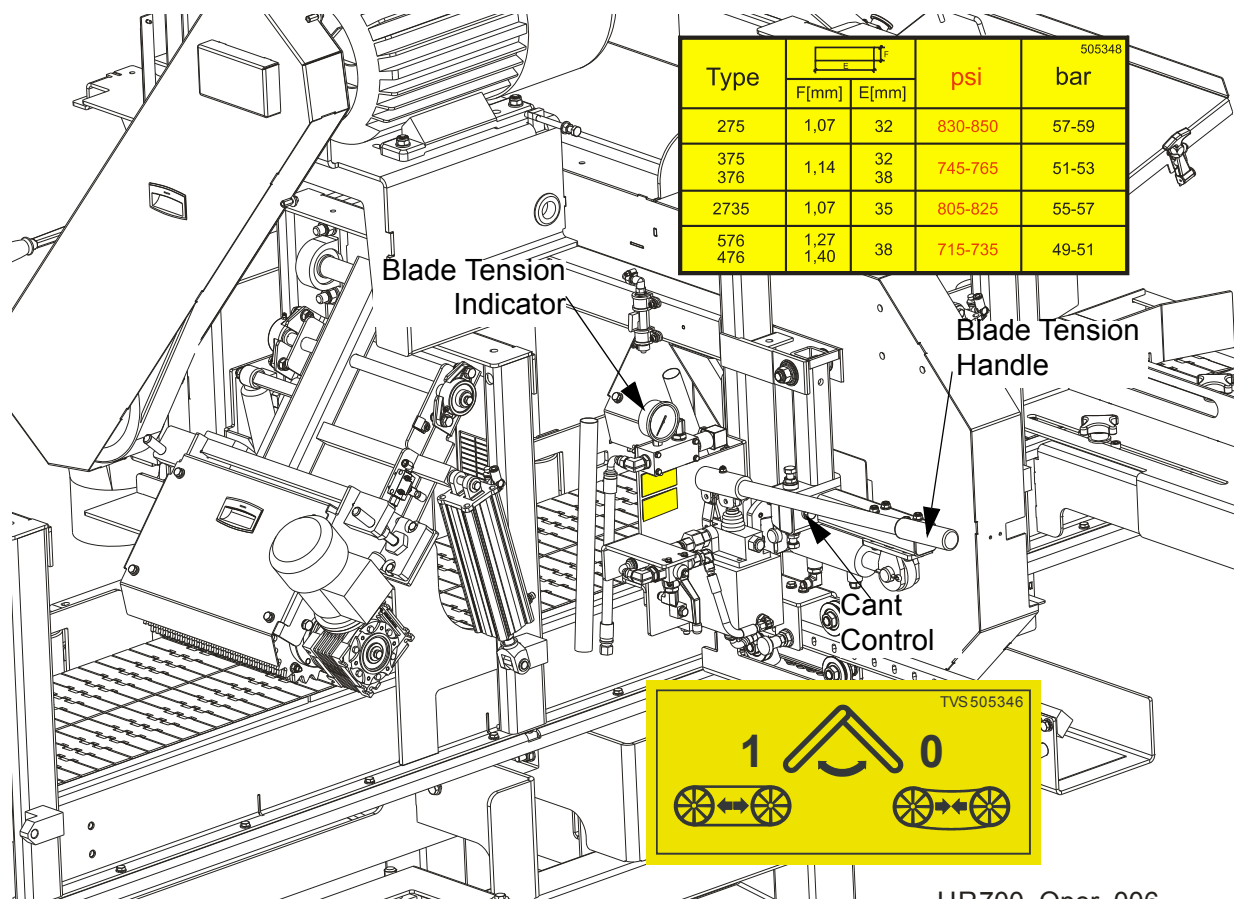

FIG. 5-1

1. Turn the key switch to the "H" position.



2. Open the blade housing cover.
3. Manually spin one of the blade wheels until the blade positions itself on the wheels.

See Figure 5-2. The blade wheels should be adjusted so that the gullet of 1 1/4" blades rides 3.0 mm (1/8") out from the front edge of the wheels (± 1.0 mm [3/64"]). The gullet of 1 1/2" blades should ride 4.5 mm (11/64") from the front edge of the wheels (± 1.0 mm

[3/64"]). Do not let the teeth ride on the belt.

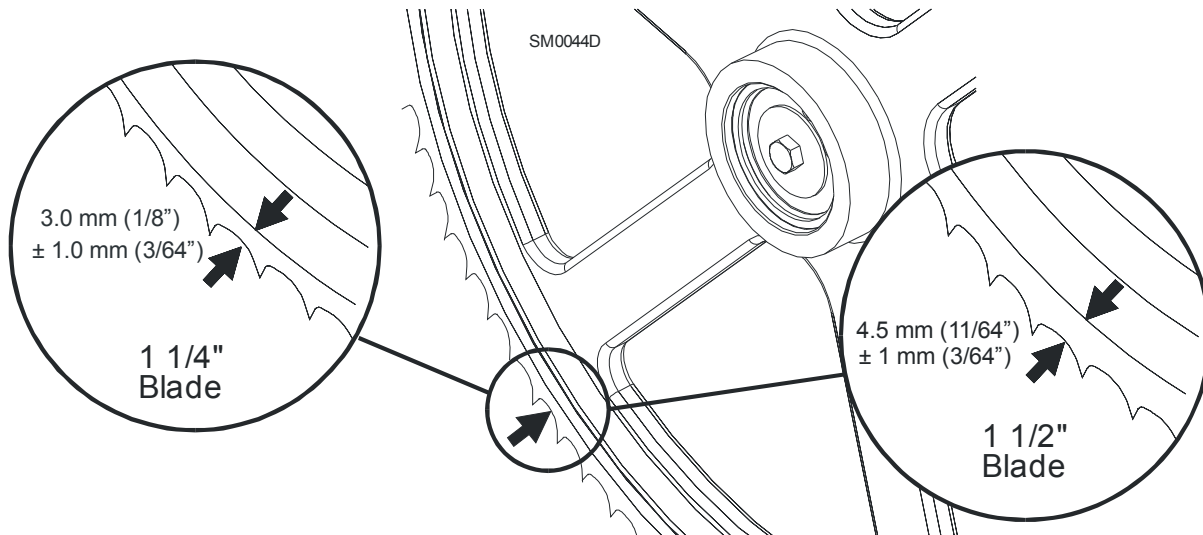

FIG. 5-2

To adjust where the blade travels on the idle-side blade wheel, use the cant control shown in **Figure 5-7**.

To move the blade out on the blade wheel, turn the cant adjustment bolt clockwise. To move the blade in on the blade wheel, turn the bolt counterclockwise.

Some adjustment in blade tension may be needed to compensate for adjustments made with the cant control.

Adjustment with the cant control is usually all that is required to track the blade properly on both blade wheels. The drive-side blade wheel will usually not have to be adjusted. If necessary, the drive-side wheel can be adjusted as follows:

Locate the nuts and the clamping screws on the drive-side of the cutting head. If the blade is too far forward on the wheel, turn the screw located on the inside of the head counterclockwise and turn the screw located on the outside of the head clockwise. Make sure to tighten the nuts against the shaft housing when adjustment is complete.

5 Alignment

Blade Wheel Alignment

5.3 Blade Wheel Alignment

The blade wheels should be adjusted so they are level in the vertical and horizontal planes. If the blade wheels are tilted up or down, the blade will want to travel in the tilted direction. If the blade wheels are tilted horizontally, the blade will not track properly on the wheels.

1. Use the blade guide alignment tool to check the vertical alignment of each blade wheel. Attach the tool to the blade near the inner blade guide mount. Be sure the tool does not rest on a tooth or burr, and is lying flat against the blade.

See Figure 5-3.

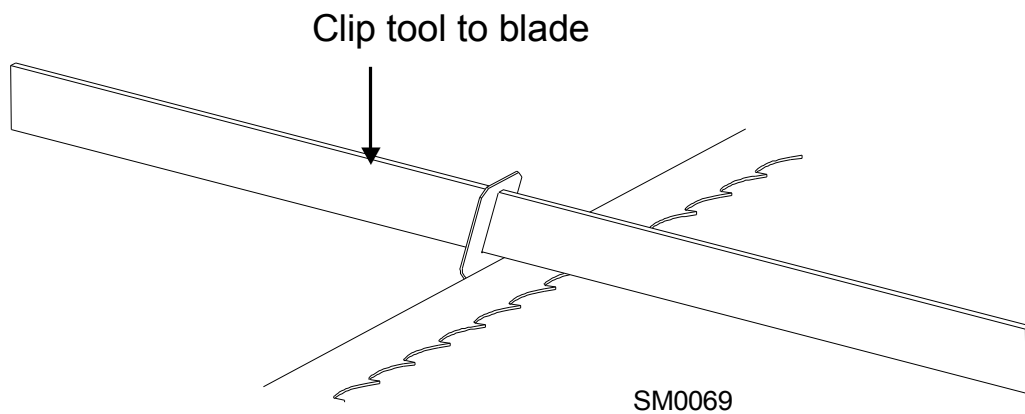

FIG. 5-3

2. Measure from the bottom of the tool to the top of the feed track.
3. If the two measurements differ by more than (± 1.0 mm ($3/64$ ")), adjust the vertical tilt of the drive-side blade wheel.

See Figure 5-4. Use the vertical adjustment screws (marked with the blue and yellow arrows in the figure below) to adjust the drive-side blade wheel. Before adjusting the wheel, loosen the drive belt using the adjustment bolts marked with the orange arrows in the figure. Loosen the jam nut and the hex socket head screw marked with the red arrow in the figure and adjust the wheel with the vertical adjustment screws. To tilt the wheel down, loosen the top adjustment screw one quarter turn. Loosen the jam nut on the bottom adjustment screw and tighten the screw. Tighten the top and bottom jam nuts. To tilt the wheel up, loosen the bottom adjustment screw one quarter turn. Loosen the jam nut on the top adjustment screw and tighten the screw. Tighten the top and bottom jam nuts. Tension the drive belt properly ([See Section 3.8](#)).

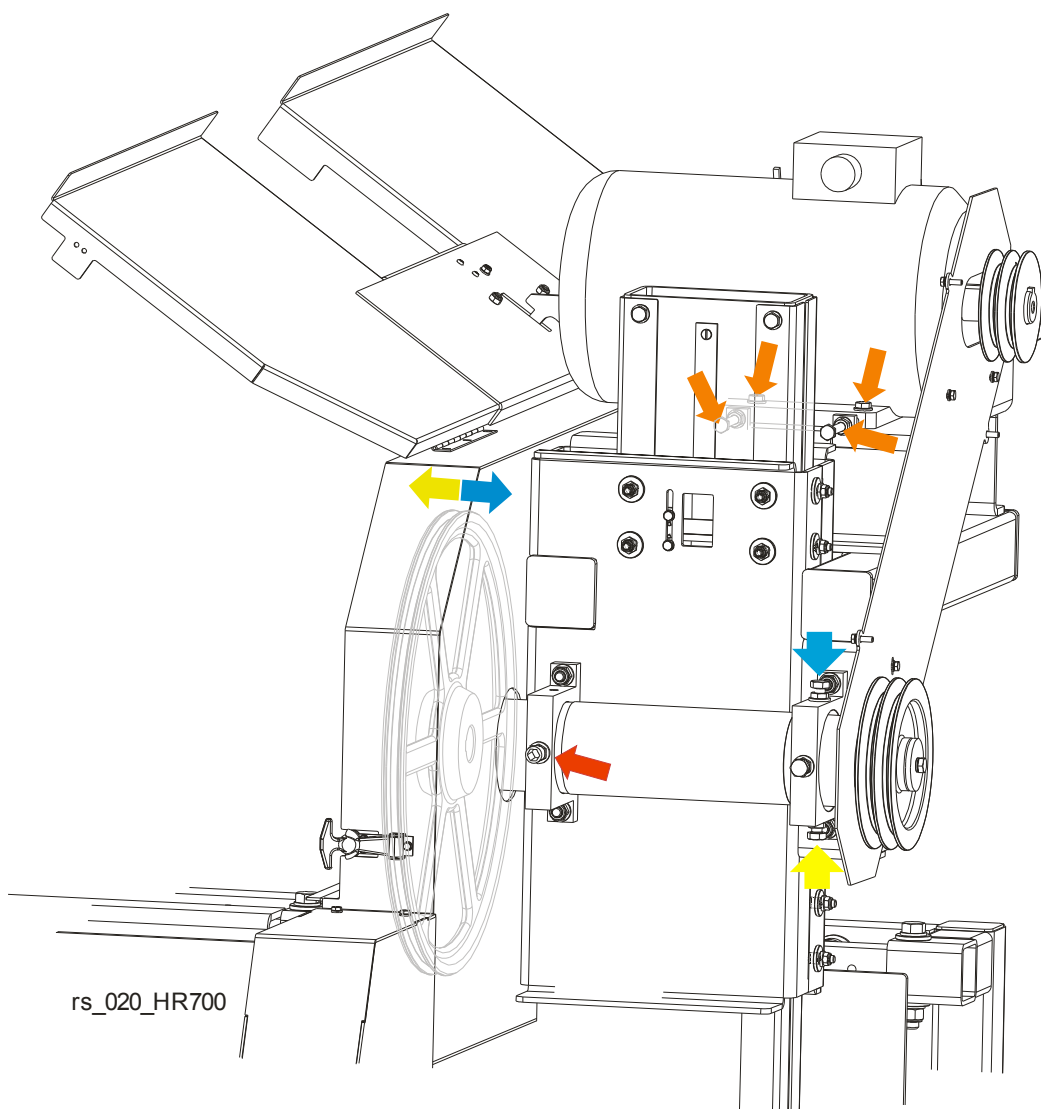

FIG. 5-4

5

Alignment

Blade Wheel Alignment

4. Recheck the vertical tilt of the drive-side blade wheel with the blade guide alignment tool. Readjust the blade wheel as necessary until the front and rear of the tool are the same distance from the feed track (± 1.0 mm (3/64")).
5. Remove the tool from the blade and reattach it near the outer blade guide assembly.
6. Measure from the tool to the feed track at both ends of the tool. If the measurements at the front and rear ends of the tool differ more than (± 1.0 mm (3/64")), adjust the vertical tilt of the idle-side blade wheel.

See Figure 5-5. Use the vertical adjustment screws to adjust the idle-side blade wheel. To tilt the wheel up, loosen the bottom adjustment screw one quarter turn. Loosen the jam nut on the top adjustment screw and tighten the screw. Tighten the top and bottom jam nuts.

To tilt the wheel down, loosen the top adjustment screw one quarter turn. Loosen the jam nut on the bottom adjustment screw and tighten the screw. Tighten the top and bottom jam nuts.

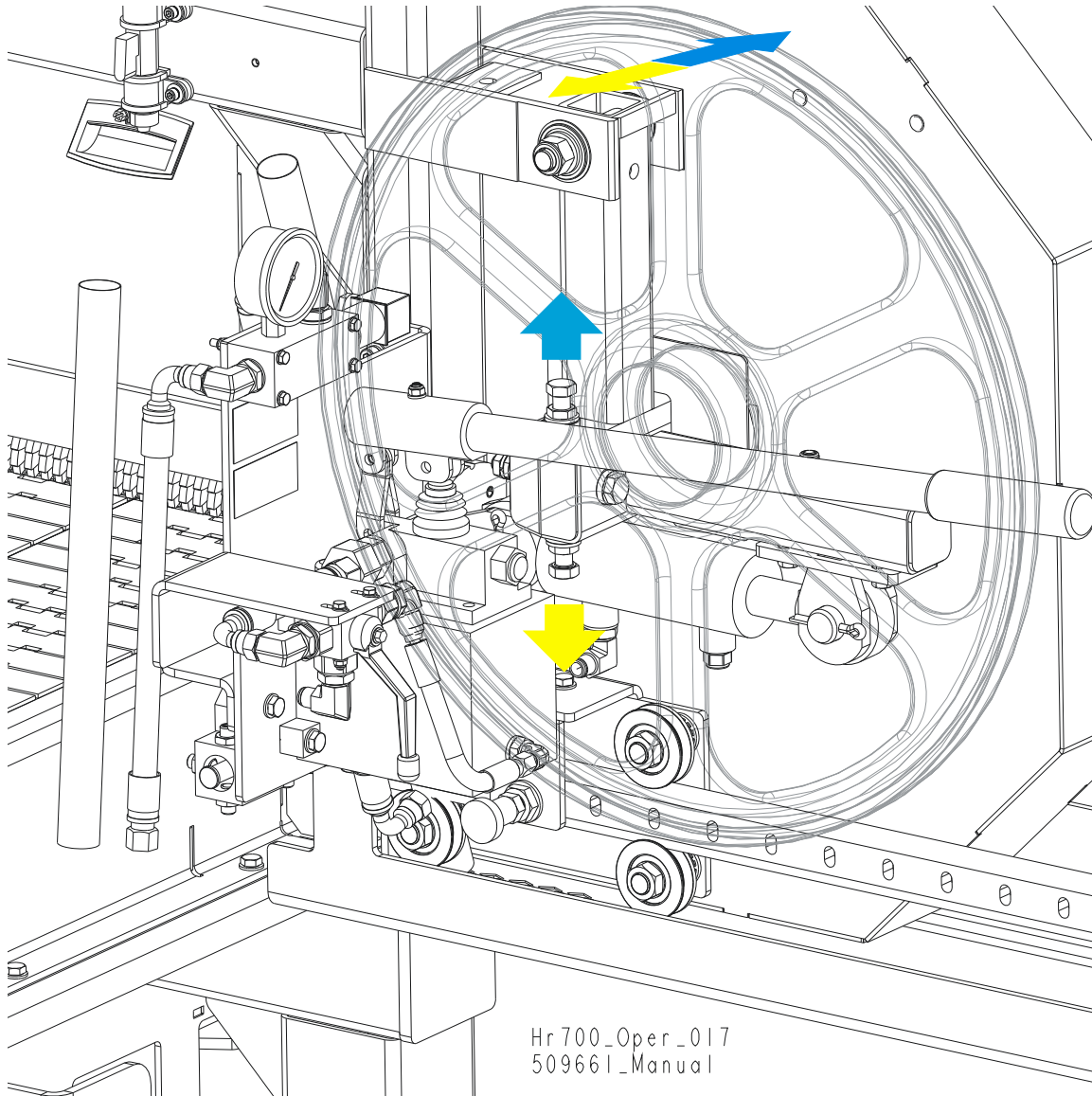

- FIG. 5-5**
7. Recheck the vertical tilt of the idle-side blade wheel with the blade guide alignment tool. Readjust the blade wheel as necessary until the front and rear of the tool are the same distance from the feed track.

5 Alignment

Blade Wheel Alignment

8. Check the position of the blade on the idle-side blade wheel.

See Figure 5-6. The horizontal tilt of the blade wheel should be adjusted so that the gullet of an 1-1/4" blade is 3.0 mm (1/8") out from the front edge of the wheel (± 1.0 mm (3/64")).

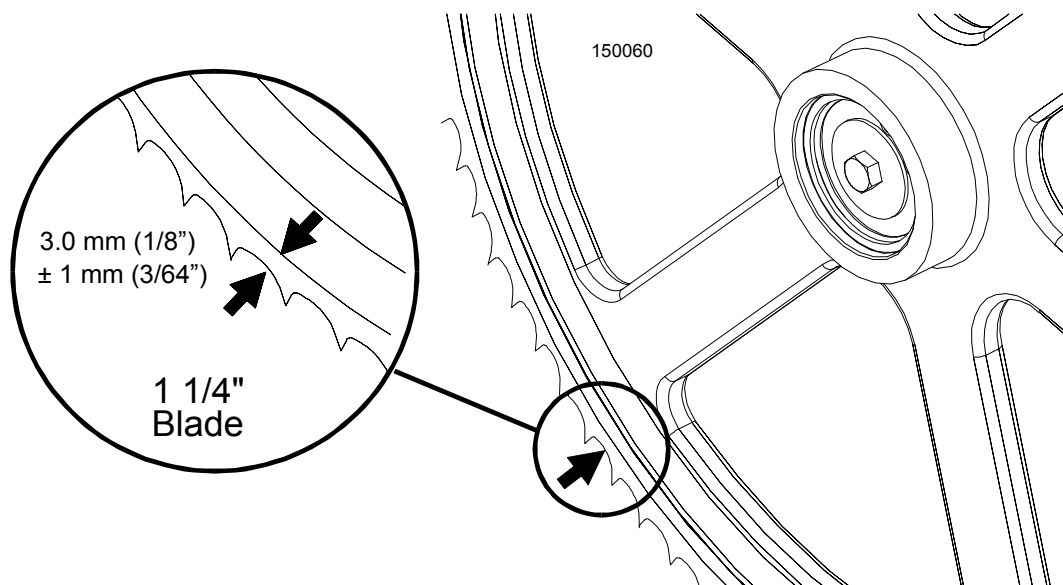

FIG. 5-6

See Figure 5-7. Use the cant control adjustment to adjust the idle-side blade wheel. If the blade is too far forward on the wheel, turn the cant control counterclockwise. If it is too far back on the wheel, turn the cant control clockwise.

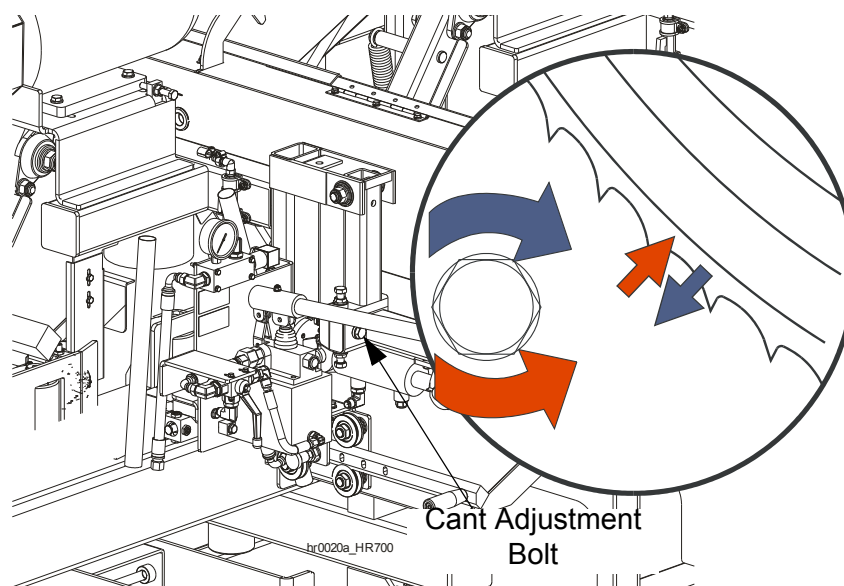

FIG. 5-7

9. Check the position of the blade on the drive-side blade wheel. The blade should be positioned on the wheel as described for the idle-side blade wheel. Adjust the drive-side blade wheel if necessary.

See Figure 5-8. Use the horizontal adjustment screws (marked with the blue and yellow arrows in the figure below) to adjust the drive-side blade wheel. Before adjusting the wheel, loosen the drive belt using the adjustment bolts marked with the orange arrows in the figure.

To move the blade back on the wheel, loosen the right adjustment screw one quarter turn. Loosen the jam nut on the left adjustment screw and tighten the screw. Tighten the left and right jam nuts.

To move the blade out on the wheel, loosen the left adjustment screw one quarter turn. Loosen the jam nut on the right adjustment screw and tighten the screw. Tighten the left and right jam nuts. When the adjustment is complete, tension the drive belt properly ([See Section 3.8](#)).

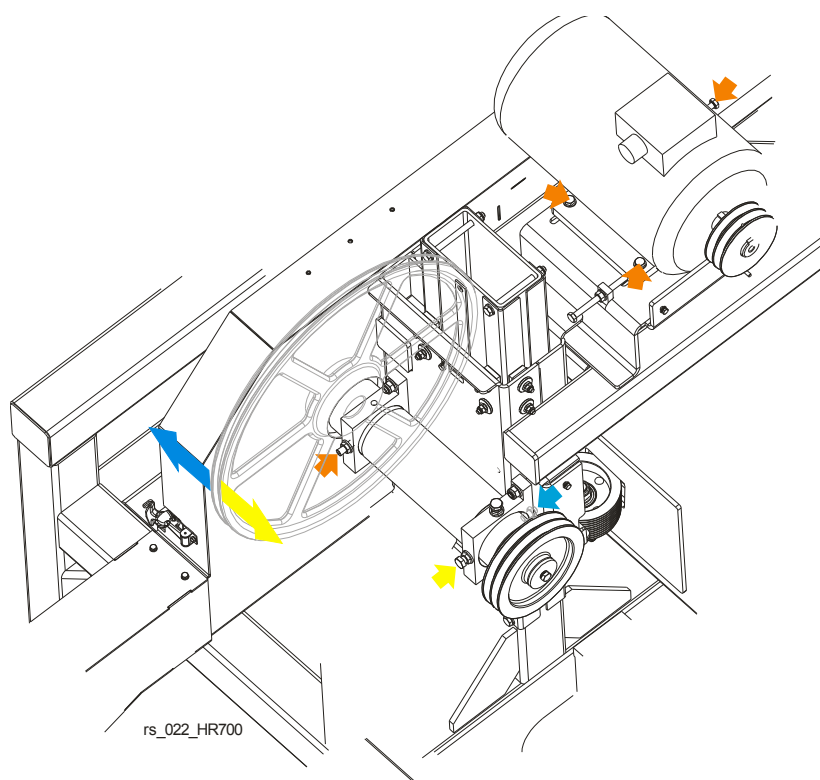

FIG. 5-8

5 Alignment

Saw Head Adjustment

5.4 Saw Head Adjustment

See Figure 5-9. The saw head should be set perpendicularly to the vertical mast. Using the adjustment screws you can adjust the saw head in relation to the mast. To raise or lower the outside of the saw head, loosen the locking nuts. Then turn the adjustment nuts clockwise to raise the outside of the saw head or counterclockwise to lower the outside of the saw head. **NOTE:** Be sure to adjust the nuts evenly so the slide pad is parallel to the mast tube.

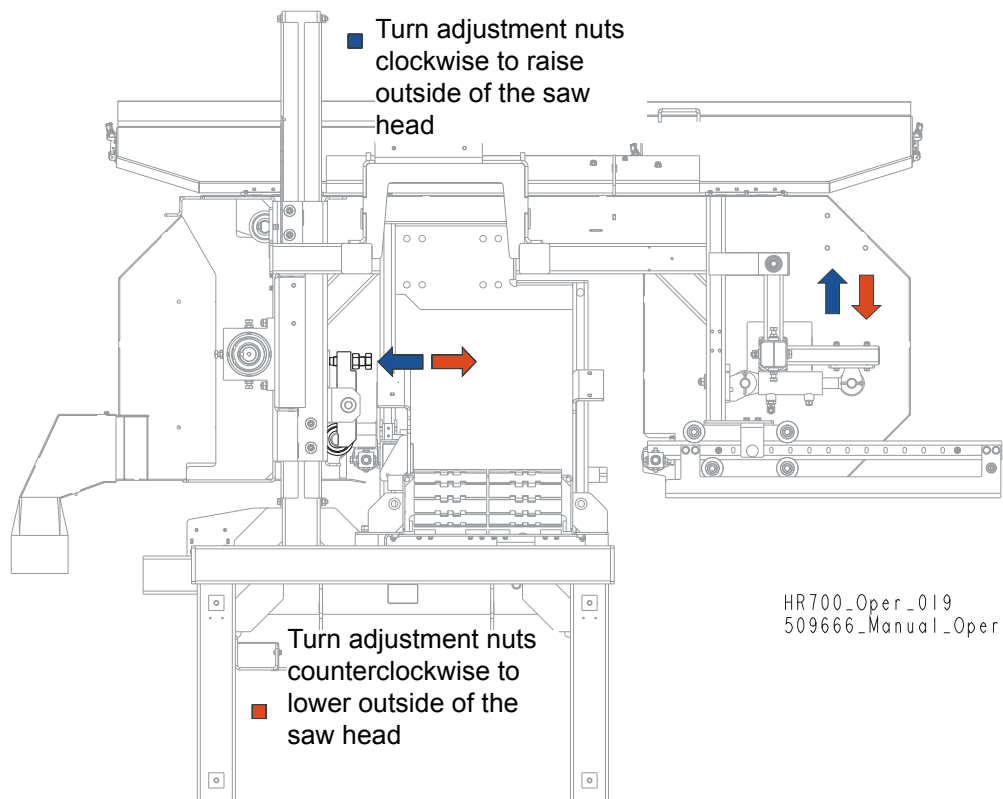

FIG. 5-9

5.5 Blade Guide Arm Vertical Adjustment

1. Adjust the blade guide arm out to within 1/2" (12.7 mm) of full open.
2. Measure the distance from the top surface of the feed track to the arm.

See Figure 5-10.

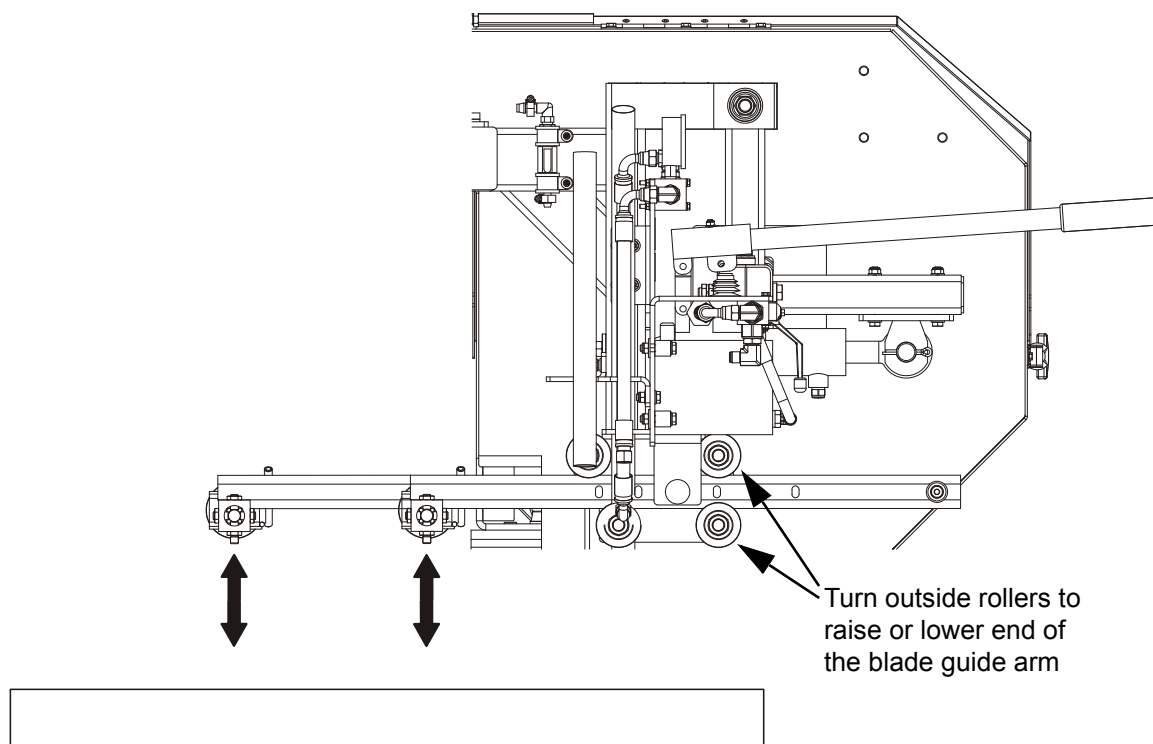

FIG. 5-10

3. Adjust the blade guide arm in to within 1/2" (12.7 mm) of full closed. Measure again the distance between the arm and the feed track.
4. Adjust the arm so that the measurement from the top of the track feed to the arm in the closed position is the same as the measurement from the top of the track feed to the arm in the open position.

If the arm is too low in the closed position, loosen the lower outside roller and tighten the upper outside roller. (See Step 5.)

If the arm is too high in the closed position, loosen the upper outside roller and tighten the lower outside roller. (See Step 5.)

5. The rollers are mounted on cam bolts that raise or lower the arm when turned.

5 Alignment

Blade Guide Arm Horizontal Adjustment

To adjust the rollers, locate the cam bolt inside the housing and turn until the arm is lowered or raised as needed. Recheck the arm in both, open and closed positions. Repeat adjustments until the arm is the same distance from the track feed in the open and closed position.

6. The blade guide arm should be snug, but not too tight, in the rollers. You should be able to move it in and out with firm hand pressure. There should be no side-to-side play.

5.6 Blade Guide Arm Horizontal Adjustment

1. Put the blade guide assembly back in the arm (if you took it out). Put the assembly back so that the flanged collar on the roller is about 3.0 mm (1/8") from the back of the blade when the arm is 15 mm (19/32") from full open.
2. Close the throat to within 15 mm (19/32") from fully closed. Check to see that the flange is the same distance from the back of the blade.

See Figure 5-11.

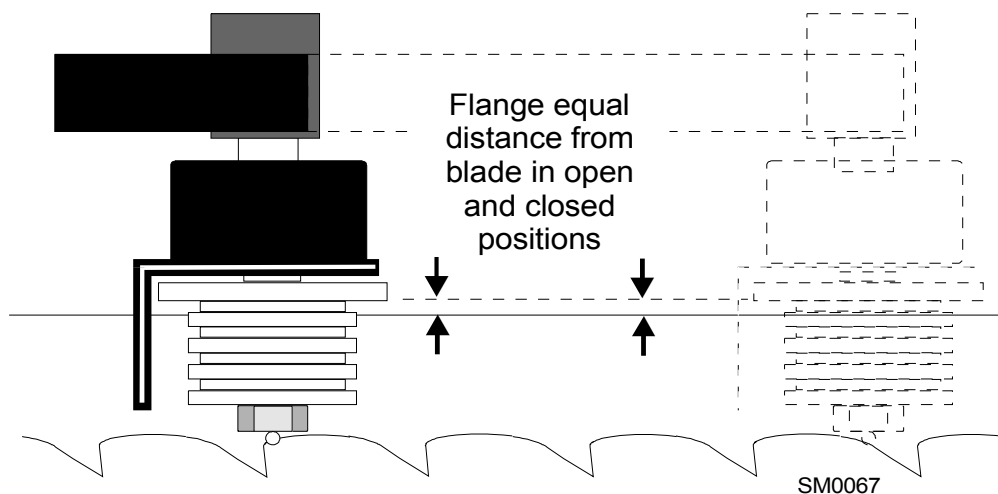

FIG. 5-11

3. If adjustment is needed, the guide rollers can be adjusted in or out on the threaded mounts to open or close the gap.

See Figure 5-12.

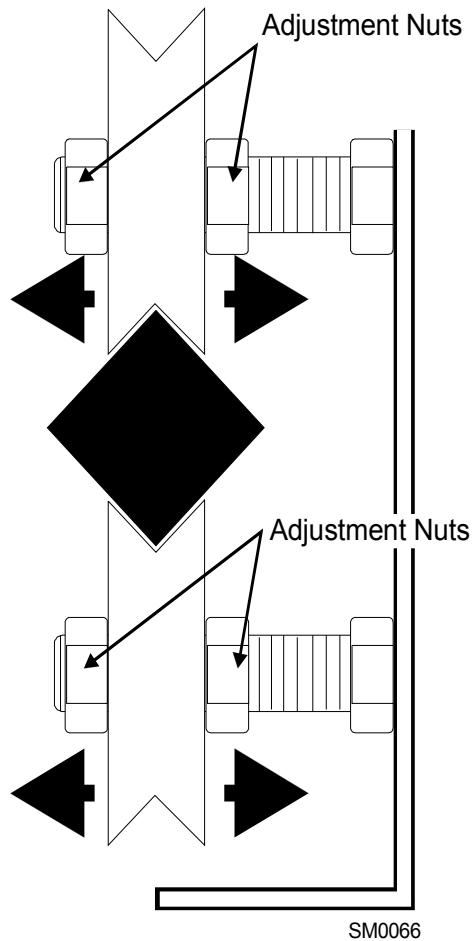

FIG. 5-12

4. Adjusting the outside two rollers inward will cause the flange to move away from the blade.
5. Adjusting the two outside rollers outward will cause the flange to move toward the blade.
6. Adjust until the roller flange is the same distance from the back of the blade in the open and closed position.

5.7 Aligning the Blade Guides

Each Wood-Mizer resaw has two blade guide assemblies that help the blade maintain a straight cut. The two blade guide assemblies are positioned on the cutting head to guide the blade on each side of the material being cut.

One blade guide assembly is mounted in a stationary position on the drive side of the cutting head. This assembly is referred to as the "inner" blade guide assembly.

The other blade guide assembly is mounted on the idle side of the cutting head. It is referred to as the "outer" assembly and is adjustable for various widths of materials to be processed.

Blade guide alignment includes four steps:

- Blade Deflection,
- Blade Guide Vertical Tilt,
- Blade Guide Flange Spacing,
- Blade Guide Horizontal Tilt.

Perform the blade guide alignment after you have aligned the blade on the wheels. After blade guide alignment, check the scale indicator to make sure it is adjusted properly ([See Section 4.13](#)).

NOTE: During blade guide alignment, remove the blade guide adjusting screws and apply lubricating oil such as 10W30 or Dexron III to each screw. This will prevent the screws and threaded holes from corroding and makes screw adjustments easier.

5.8 Blade Deflection

Perform the following steps to achieve proper blade deflection with the blade guides.

1. Raise the saw head until the blade is 200 mm (7 7/8") above the feed track. Measure the actual distance with a tape from the top of the track to the bottom of the blade.
2. Install the blade guides. Make sure the two set screws shown are threaded into the blade guide shaft until they touch each other.

See Figure 5-13.

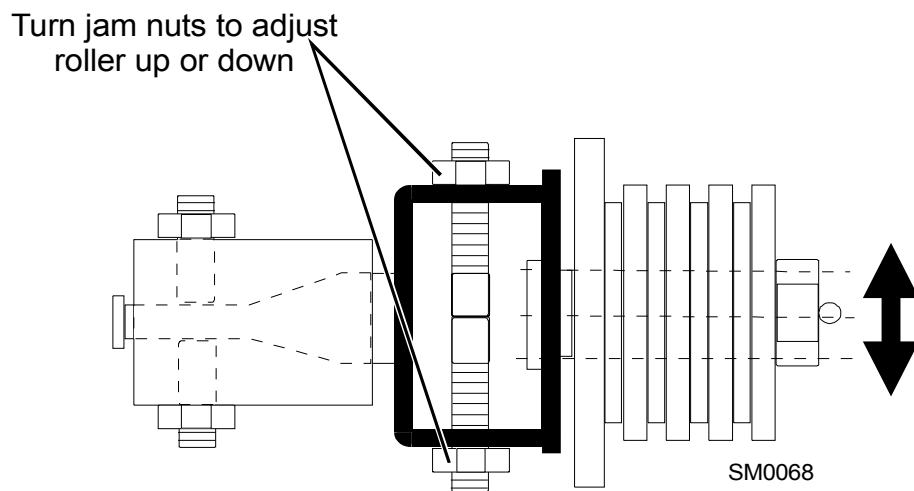

FIG. 5-13

3. Loosen the bottom jam nut and tighten the top jam nut until the blade guide deflects the blade down 6.0 mm (15/64").
4. Repeat for the other blade guide.

NOTE: Be sure that the blade guide touches the blade in both guide assemblies. The outer blade guide should be checked with the arm all the way in and all the way out.

5.9 Blade Guide Vertical Tilt Adjustment

Check that the blade guide does not tilt the blade up or down. A Blade Guide Alignment Tool (BGAT) is provided to help you measure the vertical tilt of the blade.

1. Open the blade guide arm 15 mm (19/32") from full open.
2. Clamp the alignment tool on the blade. Position the tool close to a blade guide roller. Be sure the tool does not rest on a tooth or burr, and is lying flat on the blade.

See Figure 5-14.

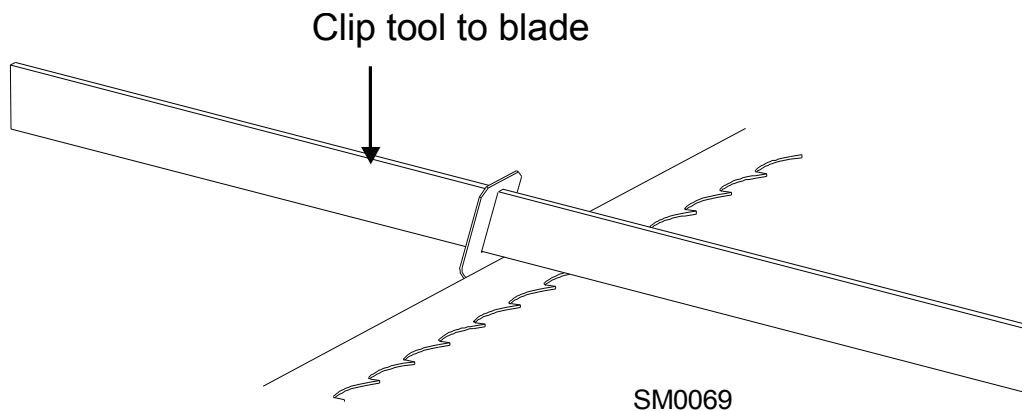

FIG. 5-14

3. Measure the distance from the bottom of the tool to the feed track chain at the center of the tool and then at the front end of the tool.
4. The two distances should be equal. If they differ, adjust the vertical tilt of the blade guide using the adjustment screws shown in the figure below.

See Figure 5-15. Loosen the jam nuts on the top and bottom vertical tilt adjustment screws. To tilt the roller up, loosen the bottom screw and tighten the top screw. To tilt the roller down, loosen the top screw and tighten the bottom screw. Tighten the jam nuts and

recheck the tilt of the blade.

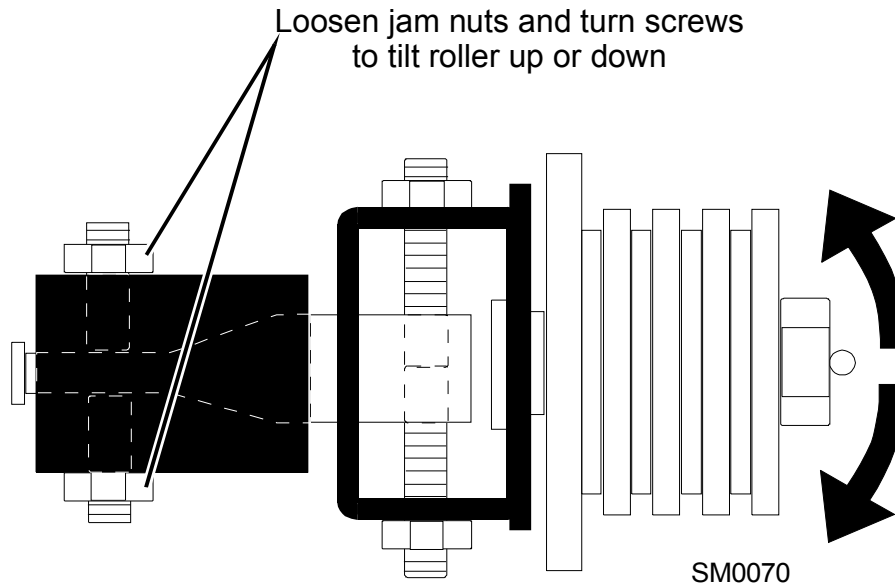

FIG. 5-15

5. Measure the distance from the bottom of the tool to the top of the feed track chain at the rear end of the tool. If the measurement does not equal the other two measurements taken, readjust the vertical tilt of the blade guide.
6. Move the blade guide alignment tool close to the other blade guide and repeat the above steps. Adjust the vertical tilt of this guide if necessary.

NOTE: If major adjustments to blade guide tilt were made, measure the distance between the blade and the feed track chain again to ensure the correct 6.0 mm (15/64") blade guide deflection. Adjust if necessary.

5 Alignment

Blade Guide Spacing

5.10 Blade Guide Spacing

HINT: When adjusting the blade guide spacing, loosen the top set screw and one side set screw only. This will ensure horizontal and vertical tilt adjustments are maintained when the set screws are retightened.

1. Adjust the inner blade guide so the blade guide flange is approximately 1.5 – 3.0 mm (1/16" - 1/8") from the back of the blade.
2. Loosen one side and one top set screw shown. Tap the blade guide forward or backward until properly positioned.

See Figure 5-16.

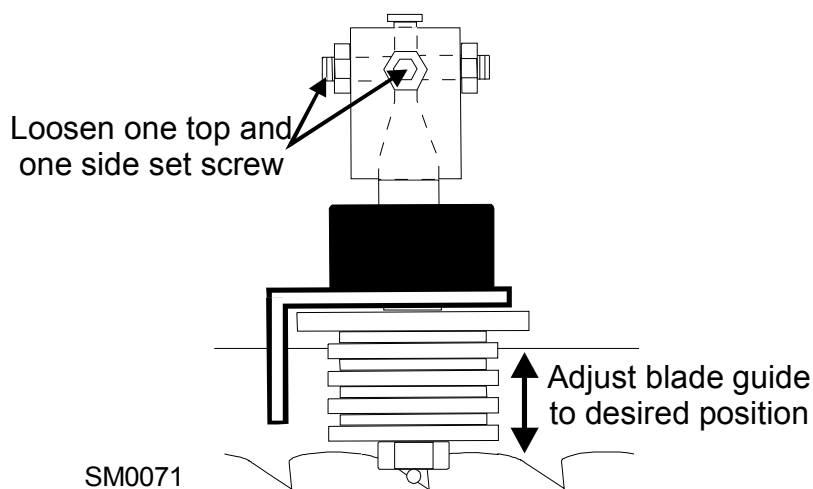

FIG. 5-16

3. Retighten the two set screws.
4. Adjust the outer blade guide in the same way so the blade guide flange is approximately 1.5 – 3.0 mm (1/16" - 1/8") from the back of the blade.

5.11 Blade Guide Horizontal Tilt Adjustment

1. Finally, both blade guides must be tilted horizontally. Adjust the blade guide arm halfway in.

See Figure 5-17.

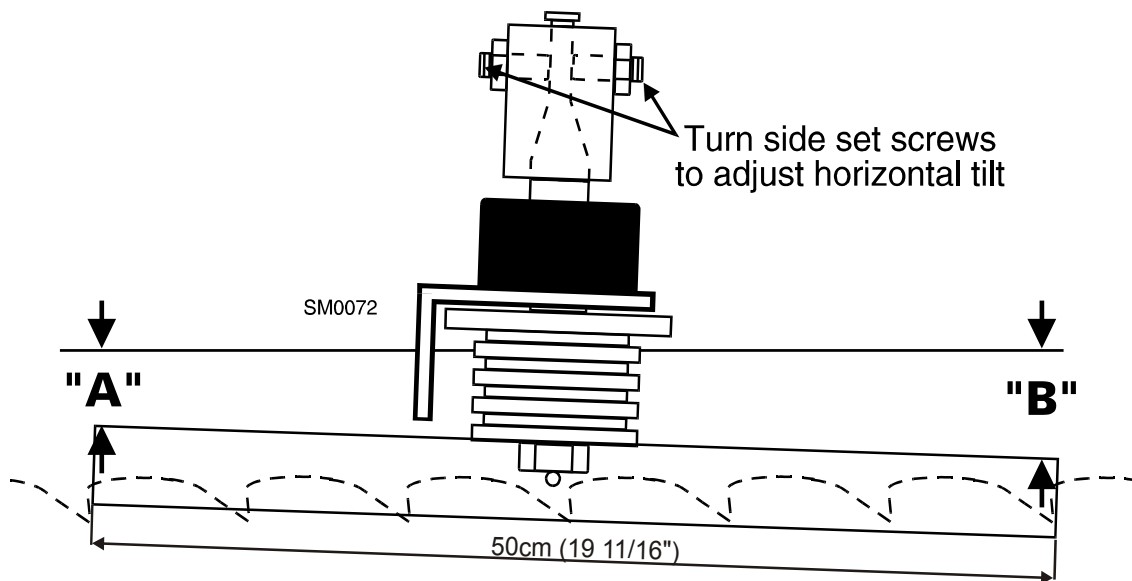

FIG. 5-17

2. Place the Blade Guide Alignment Tool against the face of the outer blade guide roller.
3. Center the tool on the roller and measure between the back edge of the blade and the ruler at the end closest to the inner blade guide ("B").
4. Measure between the back edge of the blade and the other end of the ruler ("A").
5. The roller should be tilted slightly to the left ($A = B - 6.0 \text{ mm [15/64"]}$).
6. Use the side set screws to adjust the horizontal tilt of the roller.
7. Repeat steps 3-7 for the inner blade guide roller.

NOTE: Once the blade guides have been adjusted, any cutting variances are most likely caused by the blade. See the Wood-Mizer® Blade Handbook, Form #600.

5.12 Blade Height Scale Adjustment

After the entire resaw has been aligned and all adjustments have been made, check that the blade height scale indicates the true distance from the blade to the feed track chain.

1. Measure from the bottom edge on a down-set tooth of the blade to the top of the feed track chain.

See Figure 5-18.

2. View the blade height scale with eyes level with the indicator.

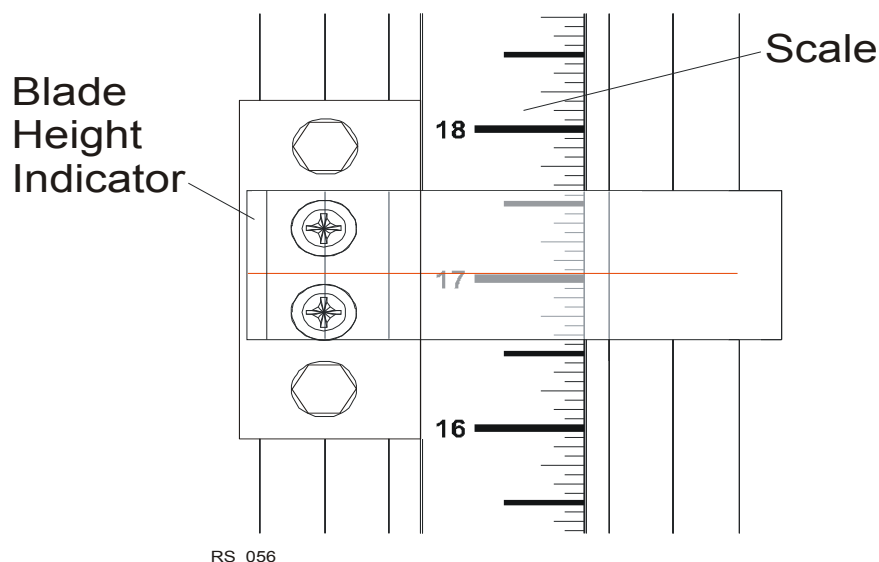

FIG. 5-18

3. Loosen the indicator bracket mounting bolts and adjust the bracket until the indicator is aligned with the correct mark on the scale. Retighten the bracket mounting bolts.

For example, if the measurement from the blade to the feed track chain is 100 mm (3 15/16"), make sure the indicator reads 100 mm (3 15/16") on the scale.

5.13 Adjustment of the Sensor Activating the Air Cylinder



WARNING! Do not for any reason adjust the sensor while the feed track chain is working. Be extremely careful when adjusting the sensor. Failure to do so may result in serious injury.

To ensure proper operation of the drive hold-down roller, adjust the sensor activating the hold-down roller air cylinder. To do this, loosen the nuts on the sensor mounting bolts and position the sensor so that it activates the air cylinder as soon as the activator plate lightly touches the bottom surface of the hold-down roller arm.

See Figure 5-19.

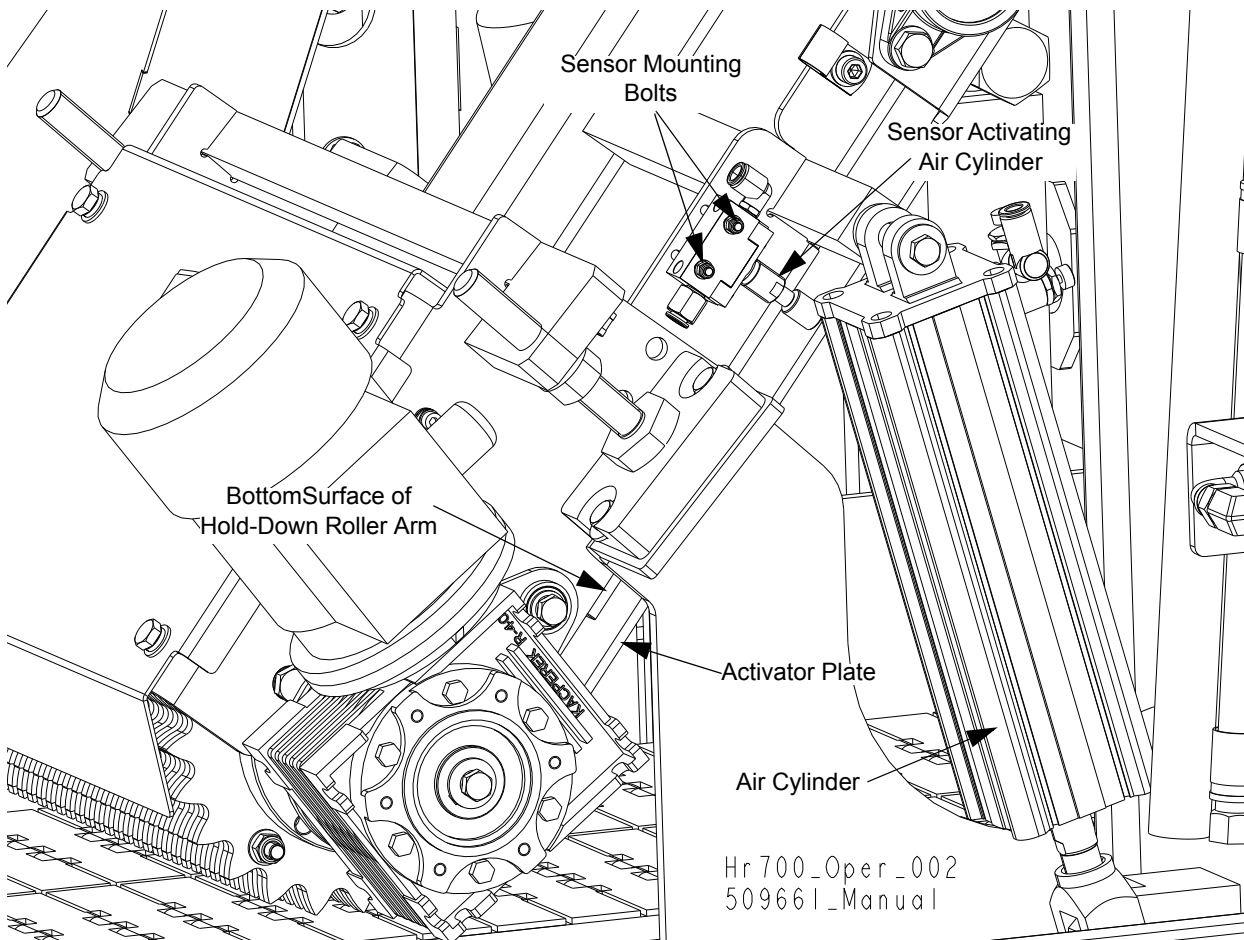

FIG. 5-19

SECTION 6 SPECIFICATIONS

6.1 Overall Dimensions

See Figure 6-1. The major dimensions of the resaw are shown below (all dimensions are in millimeters and inches).

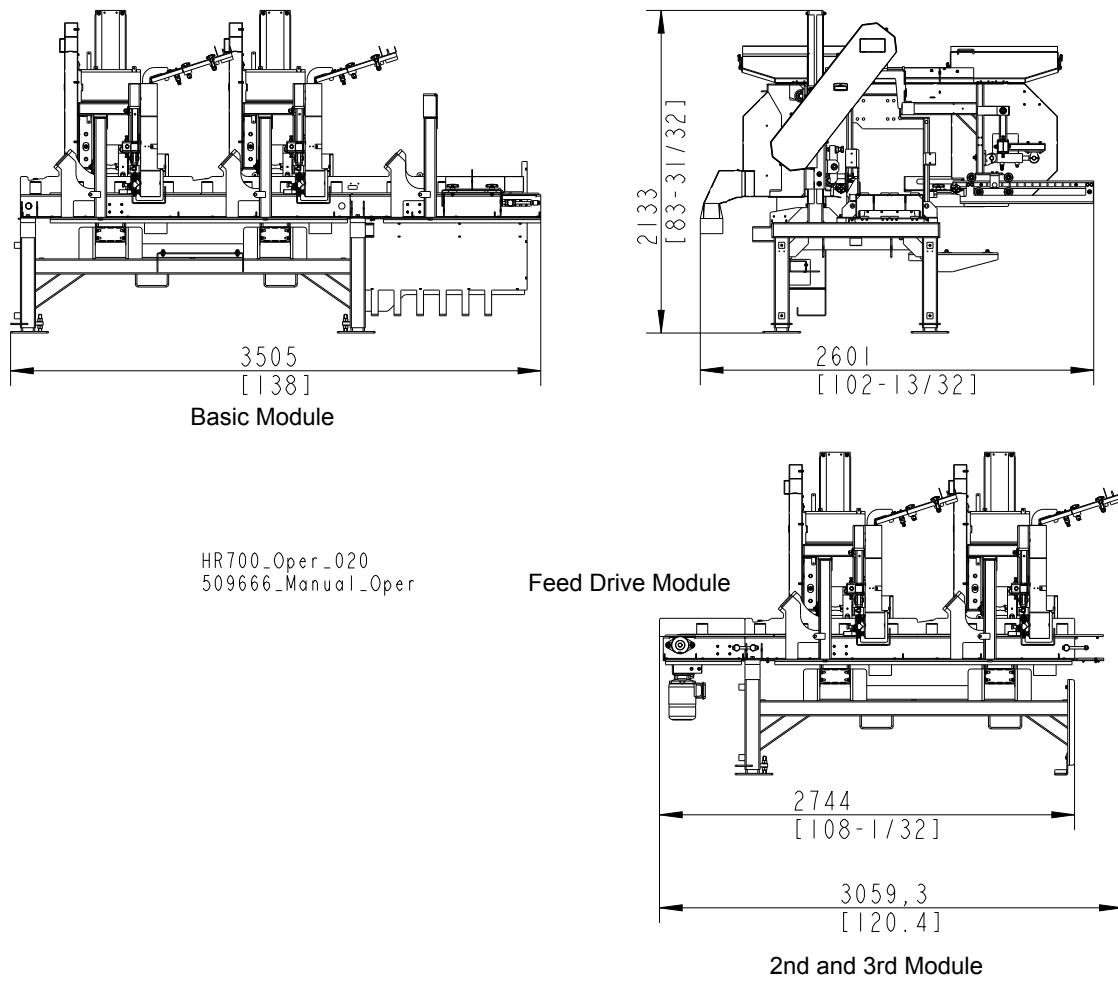

FIG. 6-1

See Figure 6-2. The major dimensions of the resaw are shown below, with CE version(all dimensions are in millimeters and inches).

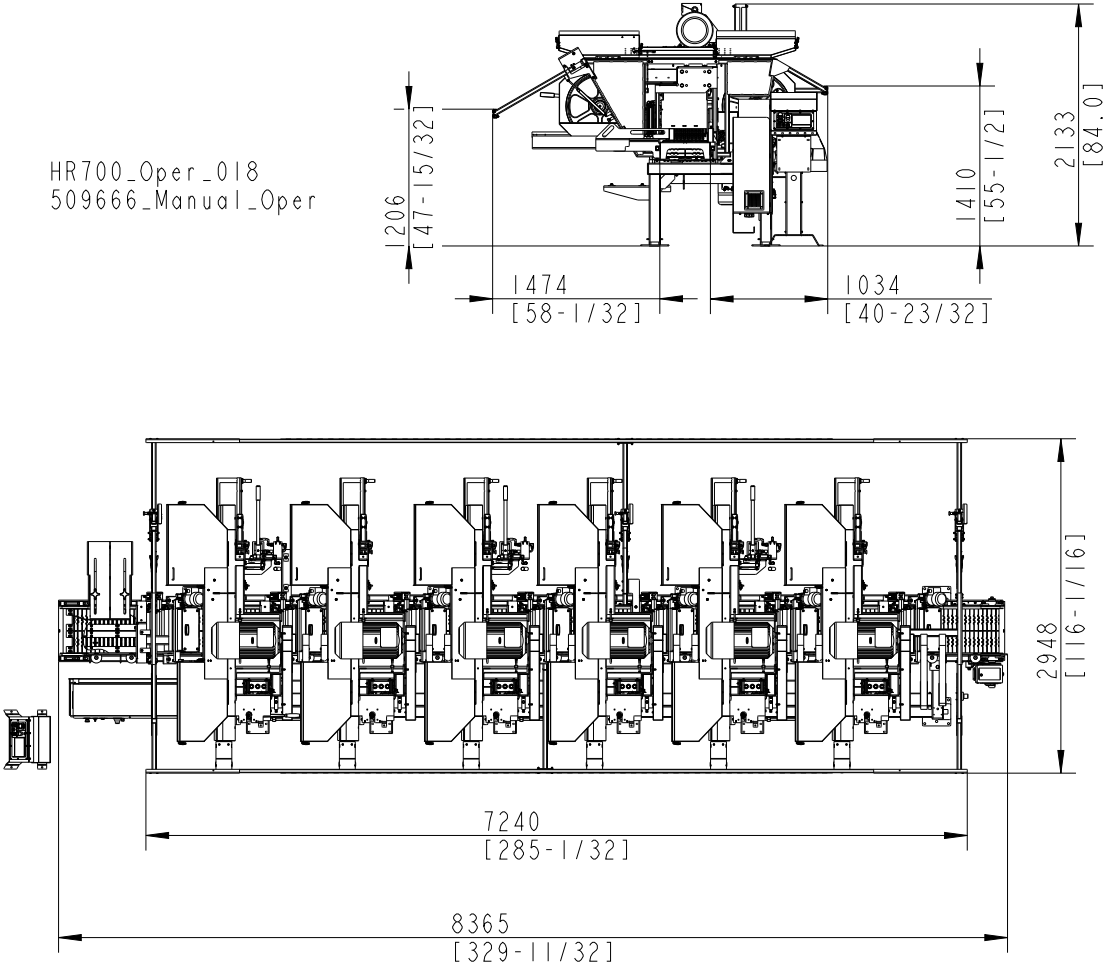

FIG. 6-2

6 Specifications

Overall Dimensions

See Table 6-1. The overall dimensions of the resaw are listed in the table below.

Weight	2530kg (5577lb) (complete HR700-2) 2400 kg (5291 lb) (base 2-head module) 1800 kg (3968 lb) (2-head extension) 130 kg (286lb) (Chain Feed Drive)
Height	2133 mm (83 31/32") (to top of the mast) 2538 mm (99 29/32") (max head height position)
Width	2598 mm (102 9/32")
Length	First Module: 3505 mm (138") Second and Third Module: 2745mm (108 1/16")

TABLE 6-1

See Figure 6-3. The major dimensions of the Idle Roller Table (SLPIRT) are shown below.

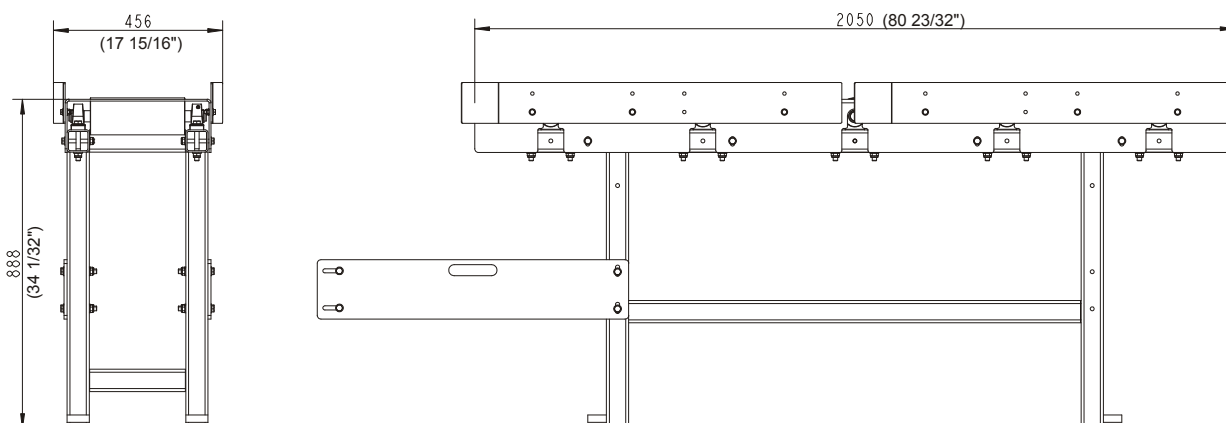

FIG. 6-3

See Figure 6-4. See the figure below for the major dimensions of the Cross Roller Table (SLPCRT).

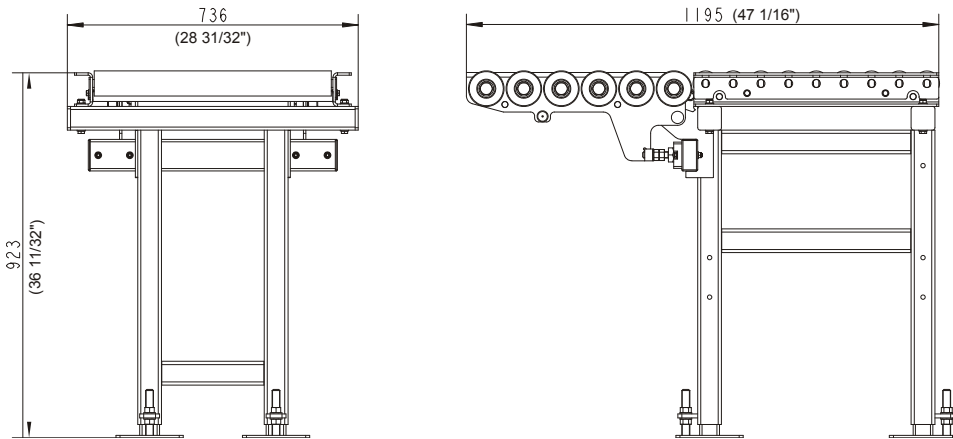

FIG. 6-4

6 Specifications

Overall Dimensions

See Figure 6-5. The figure below shows locations of the resaw legs .

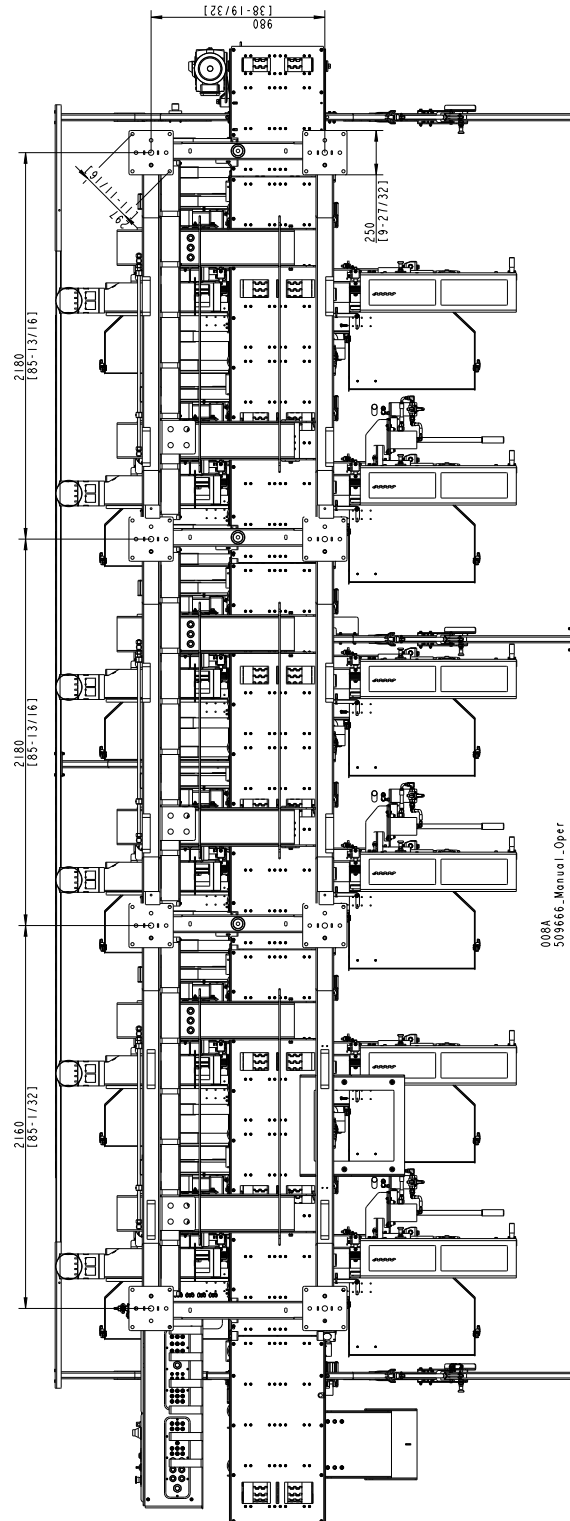

FIG. 6-5

6.2 Cutting Capacity

See Table 6-2. The material size and performance capacities of the resaw are given below.

Cutting Length	1.1 - 3.6 m (4-12 ft)
Material Height	10-400 mm (25/64" - 15 3/4")
Material Width	75-400 mm (2 61/64" -15 3/4")
Feed Speed	0-20m (0- 66ft)/min
Minimum Cutting Height	4 mm (5/32")
Maximum Cutting Height (manual up/down system)	400 mm (15 3/4")
Maximum Cutting Height (manual up/down system) Optional Rollers	250 mm (9 3/4")
Maximum Cutting Height (auto-matic up/down system)	400 mm (15 3/4")
Maximum Cutting Height (auto-matic up/down system) Optional Rollers	250 mm (9 27/32")
Distance Between Saw Blades	1090 mm (42 29/32")

TABLE 6-2

See Table 6-3. Wood-Mizer offers three types of blades to provide efficient sawing. The type of wood you saw should determine which blade you choose for optimum performance.

Motor Size	Recommended Blade Type ¹		
	Softwood	Medium Hardwood	Frozen Timber or Dense Hardwood
E15-E25	.042 x 7/8 x 1 1/4"	.042 x 7/8 x 1 1/4 "	.045 x 7/8 x 1 1/4" F1

¹ HR700 resaw is working with a blade with a length of 4.67 m(1838 19/32")

6.3 Blade Motor Specifications

See Table 6-4. See the table below for blade motor specifications for your resaw model.

Motor Type	Manufacturer	Model	Power	Other Specifications
E15 Electric	EMA-ELFA	Pssg 132M-4A-HM	11kW	400 V/50Hz; 23,2 Amp; 1450 r.p.m.
E20 Electric	EMA-ELFA	2SIE-160 L4 H	15kW	400V/50Hz; 27,7 Amp 1460 r.p.m.
E25 Electric	EMA-ELFA	PSg-160 L4 H	18,5kW	400V/50Hz; 36,9 Amp 1455 r.p.m.

TABLE 6-4

6.4 Noise Level

See Table 6-5. The noise levels of the resaw are listed below¹²³.

	Noise level
HR700EH20S-2	$L_{EX8} = 89 \text{ dB (A)}$

TABLE 6-5

1. The noise level measurement was taken in accordance with PN-EN ISO 3746 Standard . The noise exposure level given above concerns an 8-hour work day.Value for associated uncertainty K=4dB.
2. The measured values refer to emission levels, not necessarily to noise levels in the workplace. Although there is a relation between emission levels and exposure levels, it is not possible to determine with certainty if preventives are needed or are not needed. The factors affecting a current level of noise exposure during work are inter alia room characteristics and characteristics of other noise sources, e.g. number of machines and machining operations nearby. Also, the permissible exposure level value may vary depending on country. This information enables the machine's user to better identify hazards and a risk.
3. **IMPORTANT!** The total value of hand-arm vibration the operator may be exposed to does not exceed 2.5 m/s². The highest root mean square value of weighted acceleration to which the whole operator's body is subjected does not exceed 0.5 m/s².

6.5 V-Belt Sizes

See Table 6-6. Belt sizes for the resaw are shown.

Belt Description	Belt Size	Wood-Mizer Part No.
Drive Belt	3-B/HB 2240	088993
Drive Belt	3-B/HB 2160	507311
Drive Belt	2-B/HB 2240	507307
Drive Belt	2-B/HB 2160	507315
Blade Wheel Belt	B72.5	017922

TABLE 6-6

6.6 Air Supply Specification

See the table below for air supply specifications:

Air Supply	Pressure
HR700	Min. 6 bar (87 psi)

TABLE 6-6

6.7 Dust Extractor Specifications

See Table 6-7. Specifications of the dust extractors used on the resaw for each saw head are listed below.¹

Airflow	1200 m ³ /h 3937ft ³ /h
Inlet diameter	150 mm (5 29/32")
Motor power	1,5 kW
Number of sacks	1 pcs
Sack capacity	0,25 m ³ (8.8 ft) ³
Weight	110 kg (242.5 lb)
Pressure drop	1,5 kPa (0.22 psi) ¹
Recommended conveying air velocity in the duct	20 m/s 66 ft/s

TABLE 6-7

¹ The pressure drop between the inlet of the capture device and the connection to the CADES should be maximum 1,5 kPa (for the nominal air flow rate). If the pressure drop exceeds 1,5 kPa the machine might not be compatible with conventional CADES.



IMPORTANT! The dust extractor hoses must be grounded or made with materials not accumulating electrostatic charge.



CAUTION! Always turn on the dust extractor before starting the machine.

1. External chip and dust extraction equipment with fixed installations are dealt with in EN 12779:2004+A1:2009

SECTION 7 MOTOR BRAKE

7.1 Maintenance/repair

Wear of spring – applied brakes

INTORQ spring – applied brakes are wear-resistant and designed for long maintenance intervals. The friction lining and the mechanical brake components are subject to function-related wear. For safe and trouble-free operation, the brake must be checked and readjusted at regular intervals, and, if necessary, be replaced. The following table describes different causes of wear and their effects on the components of the spring-applied brake. For calculating the service life of rotor and brake and determining the maintenance intervals to be observed, the relevant factors of influence must be quantified. The most important factors are the friction work, initial speed of braking and the operating frequency. If several of the causes of wear indicated for the friction lining occur in an application at the same time, the influencing factors must be added for calculating the wear.

Inspections

To ensure safe and trouble-free operation, spring-applied brakes must be checked and maintained at regular intervals. Servicing can be made easier if good accessibility of the brakes is provided in the plant. This must be considered when installing the drives in the plant. Primarily, the necessary maintenance intervals for industrial brakes result from the load during operation. When calculating the maintenance interval, all causes for wear must be taken into account. If the brakes are not maintained, failures, production outages or plant damages may be the result. Thus, a maintenance concept adapted to the operating conditions and loads of the brake must be developed for every application. The maintenance intervals and maintenance work listed in the following table must be scheduled for the spring-applied INTORQ brake.

Maintenance intervals

Service brakes	<ul style="list-style-type: none"> ■ according to service life calculation ■ otherwise every six months ■ after 4000 operating hours at the latest
-----------------------	---

TABLE 7-0.

7.2 Maintenance



IMPORTANT! Brakes with defective armature plates, cheese head screws, springs or flanges must be replaced completely.

Please observe the following for inspections and maintenance operations:

- Remove impurities through oil and grease using brake cleaning agents, if necessary, replace brake after finding out the cause of the contamination. Dirt deposits in the air gap between stator and armature plate impair the function of the brake and must be removed.
- After replacing the rotor, the original braking torque will not be reached until the run-in operation of the friction surfaces has been completed. After replacing the rotor, run-in armature plates and flanges have an increased initial rate of wear.

Checking the rotor thickness



DANGER! The motor must not be running when checking the rotor thickness.

- Remove the motor cover and seal ring (if mounted).
- Measure the rotor thickness with a caliper gauge. On brakes with friction plates, observe edging on outer diameter of friction plate.
- Compare measured rotor thickness with minimally permissible rotor thickness [See Table 8-1](#)
- Replace the complete rotor if necessary.

Check air gap

- Measure the air gap "s_{Lü}" between armature plate and rotor using a feeler gauge (see chapter 3.3).
- Compare the measured air gap to the maximum permissible air gap "s_{Lümax}." (see table below).

- If necessary, adjust air gap to "sLürated".

Brake Type	sLürated +0.1mm -0.05mm	sLümax Service Brake	Max. adjustment permissible wear	Rotor thickness		Excess of the adjuster nut h _E max. [mm]
				min. ¹⁾ [mm]	max. [mm]	
INTORQ BFK458-25	0,4 mm (1/64")	1,0 mm (3/64")	4,0 mm (5/32")	12 mm (15/32")	16 mm (5/8")	17 mm (43/64")

TABLE 8-1

EC declaration of conformity according to EC Machinery Directive 2006/42/EC

We herewith declare,

Wood-Mizer Industries sp. z o.o.
114 Nagorna street, 62-600 Kolo; Poland.

That the following described machine in our delivered version complies with the appropriate basic safety and health requirements of the EC Machinery Directive 2006/42/EC based on its design and type, as brought into circulation by us. In case of alteration of the machine, not agreed by us, this declaration is no longer valid.

Designation of the machine: **Horizontal Resaw**
Type: HR700EH15S-1/6; HR700EH20S-1/6; HR700EH25S-1/6
No. of manufacturer:

Applicable EC Directives: EC Machinery Directive 2006/42/EC
EC Electromagnetic Compatibility Directive
2004/108/EC

Applicable Harmonized Standards: PN-EN ISO 12100:2012
PN-EN 1807-2:2013-08
PN-EN 13849-1:2008
PN-EN 60204-1:2010
PN-EN 13857:2010

Responsible for Technical Documentation: Adam Kubiak / R&D Manager
Wood-Mizer Industries Sp. z o.o.
62-600 Koło, ul. Nagórna 114
Tel. +48 63 26 26 000

Date/Authorized Signature: **Adam Kubiak**

Title : R&D Manager