

user manual

Instrukcja obsługi | Руководство пользователя
Manuel de l'Utilisateur | Betriebsanweisung
Bruksanvisning | Manual del Usuario
Betjeningsvejledning | Gebruikershandleiding
Käyttöohjeet | Manual de utilizare | Bruksanvisning
Manuale d'uso | Příručka uživatele

Zachować do przyszłego użytku
Сохраните для последующего использования
A conserver pour une utilisation future
Für zukünftige Benutzung aufbewahren
Behold for senere bruk
Säilytä nämä käyttöohjeet tulevaa tarvetta marten
Opbevar manualen til fremtidig brug
Bewaren voor gebruik in de toekomst
Conservare il presente manuale a l'uso futuro
Păstrați acest manual pentru utilizare viitoare
Conservar para futuras consultas
Uchovajte pro další použití

Horizontal Resaw HR

Safety, Operation, Maintenance & Parts Manual

HRE11S
HRE15S

rev.A2.00
rev.A2.00



Safety is our #1 concern! Read and understand all safety information and instructions before operating, setting up or maintaining this machine.

September 2007

Form #1006

Table of Contents

Section-Page

SECTION 1	SAFETY	1-1
1.1	Safety Symbols.....	1-1
1.2	Safety Instructions.....	1-2
SECTION 2	OPERATION	2-1
2.1	Control Overview	2-1
2.2	Resaw Setup	2-3
2.3	Replacing The Blade	2-12
2.4	Tensioning The Blade.....	2-13
2.5	Tracking The Blade	2-14
2.6	Saw Height Adjustment.....	2-15
2.7	Tilt	2-18
2.8	Guide Fence Adjustment	2-19
2.9	Blade Guide Arm Adjustment.....	2-20
2.10	Machine Start.....	2-21
2.11	Water Lube Operation	2-24
2.12	Operation Procedure.....	2-25
SECTION 3	MAINTENANCE	3-1
3.1	Wear Life.....	3-1
3.2	Blade Guides	3-2
3.3	Sawdust Removal	3-2
3.4	Vertical Mast	3-2
3.5	Miscellaneous Lubrication	3-3
3.6	Blade Tensioner.....	3-4
3.7	Belts.....	3-4
3.8	Drive Belt Adjustment.....	3-5
3.9	Feed Track Chain Tension.....	3-8
3.10	Up/Down System.....	3-9
SECTION 4	ALIGNMENT	4-1
4.1	Alignment Procedures	4-1
4.2	Blade Installation And Tracking	4-2
4.3	Blade Wheel Alignment	4-4
4.4	Saw Head Adjustment	4-9
4.5	Blade Guide Arm Vertical Adjustment	4-10
4.6	Blade Guide Arm Horizontal Adjustment.....	4-11
4.7	Aligning the Blade Guides	4-13
4.8	Blade Deflection.....	4-14
4.9	Blade Guide Vertical Tilt Adjustment.....	4-15
4.10	Blade Guide Spacing	4-17
4.11	Blade Guide Horizontal Tilt Adjustment	4-18
4.12	Clamp Roller Alignment	4-19
4.13	Blade Height Scale Adjustment.....	4-21

Table of Contents

Section-Page

SECTION 5	SPECIFICATIONS	5-1
5.1	Overall Dimensions	5-1
5.2	Cutting Capacity	5-4
5.3	Blade Motor Specifications	5-5
5.4	Electrical Diagram, CE version, HR2	5-6
5.5	Electrical Diagram, CE version, HR4	5-7
5.6	Electrical Diagram, CE version, HR6	5-9
5.7	Electrical Component List, HR	5-12
5.8	V-Belt Sizes	5-14
5.9	Dust Extractor Specifications	5-14
SECTION 6	REPLACEMENT PARTS	6-1
6.1	How To Use The Parts List	6-1
6.1	Sample Assembly	6-1
6.2	Blade Guide Assembly, Idle Side	6-2
6.3	Blade Guide Assembly, Drive Side	6-3
6.4	Blade Guide Arm Assembly	6-4
6.5	Drive-Side Blade Wheel Assembly	6-5
6.6	Idle-Side Blade Wheel Assembly	6-7
6.7	Blade Tensioner Assembly	6-9
6.8	Middle Throat Screw	6-10
6.9	Water Bottle Assembly	6-11
6.10	Saw Head Warning Decals	6-13
6.11	Blade Housing Cover	6-15
6.12	Control Box	6-17
6.13	Saw Head Height Adjustment Screw	6-19
6.14	Mast Tilt Adjustment Screw	6-20
6.15	Vertical Mast Slide Pads	6-21
6.16	Motor Assembly	6-23
6.17	Feed Chain Drive & Tensioner	6-24
6.18	Hold-Down Rollers & Log Guide	6-26
6.19	Hold-Down Adjustable Roller (Option)	6-28
6.20	Main Base Frame	6-29
6.21	Main Module Feed Track	6-30
6.22	Additional Module Base Frame	6-31
6.23	Additional Module Feed Track	6-32
6.24	Idle Roller Table, SLPIRT	6-33
6.25	Cross Roller Table, SLPCRT	6-35
6.26	Additonal Control Box Support Tube	6-37
SECTION 7	DC ELECTROMAGNETIC BRAKE	7-1
7.1	Design and Principle of Operation	7-1
7.2	Service	7-2

SECTION 1 SAFETY

1.1 Safety Symbols

The following symbols and signal words call your attention to instructions concerning your personal safety. Be sure to observe and follow these instructions.



DANGER! indicates an imminently hazardous situation which, if not avoided, will result in death or serious injury.



WARNING! suggests a potentially hazardous situation which, if not avoided, could result in death or serious injury.



CAUTION! refers to potentially hazardous situations which, if not avoided, may result in minor or moderate injury or damage to equipment.



IMPORTANT! indicates vital information.

NOTE: gives helpful information.



Warning stripes are placed on areas where a single decal would be insufficient. To avoid serious injury, keep out of the path of any equipment marked with warning stripes.

1.2 Safety Instructions

NOTE: ONLY safety instructions regarding personal injury are listed in this section. Caution statements regarding only equipment damage appear where applicable throughout the manual.

Observe Safety Instructions



IMPORTANT! Read the entire Operator's Manual before operating the resaw. Take notice of all safety warnings throughout this manual and those posted on the machine. Keep this manual with this machine at all times, regardless of ownership.

Also read any additional manufacturer's manuals and observe any applicable safety instructions including dangers, warnings, and cautions.

Only persons who have read and understood the entire operator's manual should operate the resaw. The resaw is not intended for use by or around children.

IMPORTANT! It is always the owner's responsibility to comply with all applicable federal, state and local laws, rules and regulations regarding the ownership and operation of your Wood-Mizer resaw. All Wood-Mizer resaw owners are encouraged to become thoroughly familiar with these applicable laws and comply with them fully while using the machine.



1 Safety

Wear Safety Clothing

Wear Safety Clothing



WARNING! Secure all loose clothing and jewelry before operating the resaw. Failure to do so may result in serious injury or death.

WARNING! Always wear gloves and eye protection when handling bandsaw blades. Changing blades is safest when done by one person! Keep all other persons away from area when coiling, carrying or changing a blade. Failure to do so may result in serious injury.

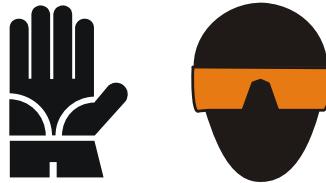

WARNING! Always wear eye, ear, respiration, and foot protection when operating or servicing the resaw.



Keep Resaw And Area Around Resaw Clean



DANGER! Maintain a clean and clear path for all necessary movement around the resaw and lumber stacking areas. Failure to do so will result in serious injury.

Dispose Of Sawing By-Products Properly



IMPORTANT! Always properly dispose of all sawing by-products, including sawdust and other debris.

Check Resaw Before Operation

 **DANGER!** Make sure all guards and covers are in place and secured before operating the resaw. Failure to do so may result in serious injury.



Keep Persons Away

 **DANGER!** Keep all persons out of the path of moving equipment and lumber when operating the resaw. Failure to do so will result in serious injury.

DANGER! Always be sure all persons are out of the path of the blade before starting the motor. Failure to do so will result in serious injury.

 **WARNING!** Allow blade to come to a complete stop before opening the blade housing cover. Failure to do so will result in serious injury.

Keep Hands Away



DANGER! Always shut off the blade motor before changing the blade. Failure to do so will result in serious injury.

DANGER! Motor components can become very hot during operation. Avoid contact with any part of a hot motor. Contact with hot motor components can cause serious burns. Therefore, never touch or perform service functions on a hot motor. Allow the motor to cool sufficiently before beginning any service function.

DANGER! Always keep hands away from moving bandsaw blade. Failure to do so will result in serious injury.

DANGER! Always be aware of and take proper protective measures against rotating shafts, pulleys, fans, etc. Always stay a safe distance from rotating members and make sure that loose clothing or long hair does not engage rotating members resulting in possible injury.



WARNING! Use extreme caution when spinning the blade wheels by hand. Make sure hands are clear of blade and wheel spokes before spinning. Failure to do so may result in serious injury.

Use Proper Maintenance Procedures



DANGER! Make sure all electrical installation, service and/or maintenance work is performed by a qualified electrician and is in accordance with applicable electrical codes.

DANGER! Hazardous voltage inside the electric boxes and at the motor can cause shock, burns, or death. Disconnect and lock out power supply before servicing! Keep all electrical component covers closed and securely fastened during resaw operation.



WARNING! Consider all electrical circuits energized and dangerous.

WARNING! Disconnect and lock out power supply before servicing the resaw! Failure to do so may result in serious injury.

WARNING! Never assume or take the word of another person that the power is off; check it out and lock it out.

WARNING! Do not wear rings, watches, or other jewelry while working around an open electrical circuit.

WARNING! Remove the blade before performing any service to the motor or resaw. Failure to do so may result in serious injury.



DANGER! Never clean the blade or blade wheels using the hand-held brush or scraper whilst the saw blade is in motion.

1 Safety

Keep Safety Labels In Good Condition

Keep Safety Labels In Good Condition



IMPORTANT! Always be sure that all safety decals are clean and readable. Replace all damaged safety decals to prevent personal injury or damage to the equipment. Contact your local distributor, or call your Customer Service Representative to order more decals.

IMPORTANT! If replacing a component which has a safety decal affixed to it, make sure the new component also has the safety decal affixed.

See Table 1-1. Pictogram decals used to warn and inform the user about danger in the resaw.

TABLE 1-1

Decal View	W-M No.	Description
	096317	CAUTION! Read thoroughly the manual before operating the machine. Observe all safety instructions and rules when operating the sawmill.
	099220	CAUTION! Close all guards and covers before starting the machine.

TABLE 1-1

<p>099219</p>	<p>099219</p>	<p>Blade tension. Turning the bolt clockwise will increase the blade tension and turning the bolt counterclockwise will decrease the tension.</p>
<p>099221</p>	<p>099221</p>	<p>CAUTION! Keep all persons a safe distance away from work area when operating the machine.</p>
<p>099222</p>	<p>099222</p>	<p>CAUTION! Sawdust outlet. Protect eyes!</p>
<p>096321</p>	<p>096321</p>	<p>Blade movement direction</p>

1 **Safety**
Keep Safety Labels In Good Condition

TABLE 1-1







	<p>S12004G</p>	<p>CAUTION! Always wear safety goggles when operating the sawmill!</p>
	<p>S12005G</p>	<p>CAUTION! Always wear protective ear muffs when operating the sawmill!</p>
	<p>501465</p>	<p>CAUTION! Always wear safety boots when operating the sawmill</p>
	<p>501467</p>	<p>Lubrication Point</p>
 <p>P11789/PL</p>	<p>P11789</p>	<p>Aligning the blade on the wheels</p>

TABLE 1-1

 <p style="text-align: right; font-size: small;">092597</p>	<p>092597</p>	<p>Setting the blade tension indicator</p>
	<p>P85070</p>	<p>CE safety certification</p>
 <p style="text-align: right; font-size: small;">099401</p>	<p>099401</p>	<p>Russian safety certification</p>
 <p style="text-align: right; font-size: small;">S20097</p>	<p>S20097</p>	<p>Motor rotation direction</p>

SECTION 2 OPERATION

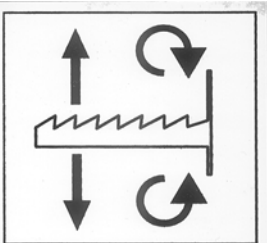
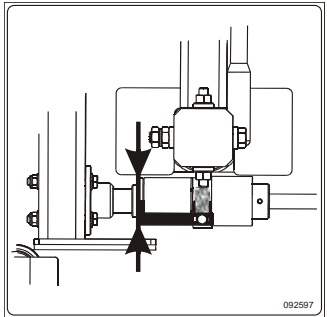
2.1 Control Overview

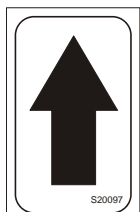
1. Control Panel

See **Figure 2-1**. The control panel includes switches to start and stop the feed track and the saw head.

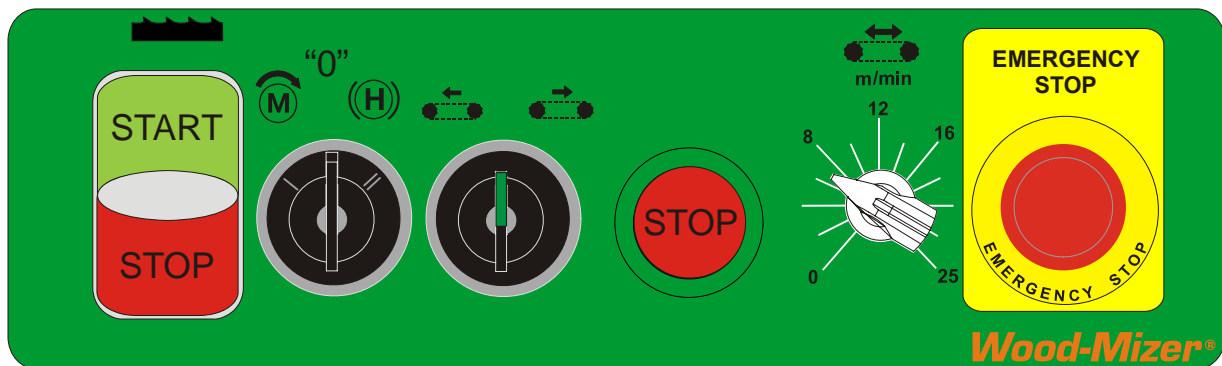





FIG. 2-1 CONTROL PANEL COMPONENTS

2. Blade Drive

 To start the blade motor, turn the key switch to the  position. Then press START button. To stop the blade motor, press STOP switch.

3. Feed Track

 To start spinning the feed track forward or backward, turn the switch left or right. To stop the feed track press the STOP button



4. Feed Track Speed Adjustment



The feed track speed switch controls the speed at which the feed track moves. Turn the switch clockwise to increase the speed, counterclockwise to reduce the speed.

5. Key Switch

The key switch has three positions:

- "0" position - all electrical circuits are off,
-  position - all electrical circuits are on,
-  position - releases the motor disk brake, the blade and the track feed motors are off.

6. Emergency Stop

Push the emergency stop button to stop the blades and the track feed motor. Turn the emergency stop clockwise to release the stop. The resaw will not restart until the emergency stop is released.

2.2 Resaw Setup

The Horizontal Resaw is delivered to the customer place in modules. The HR modules must be mounted together.

See **Figure 2-2**. Attach the base to the additional module (or modules).

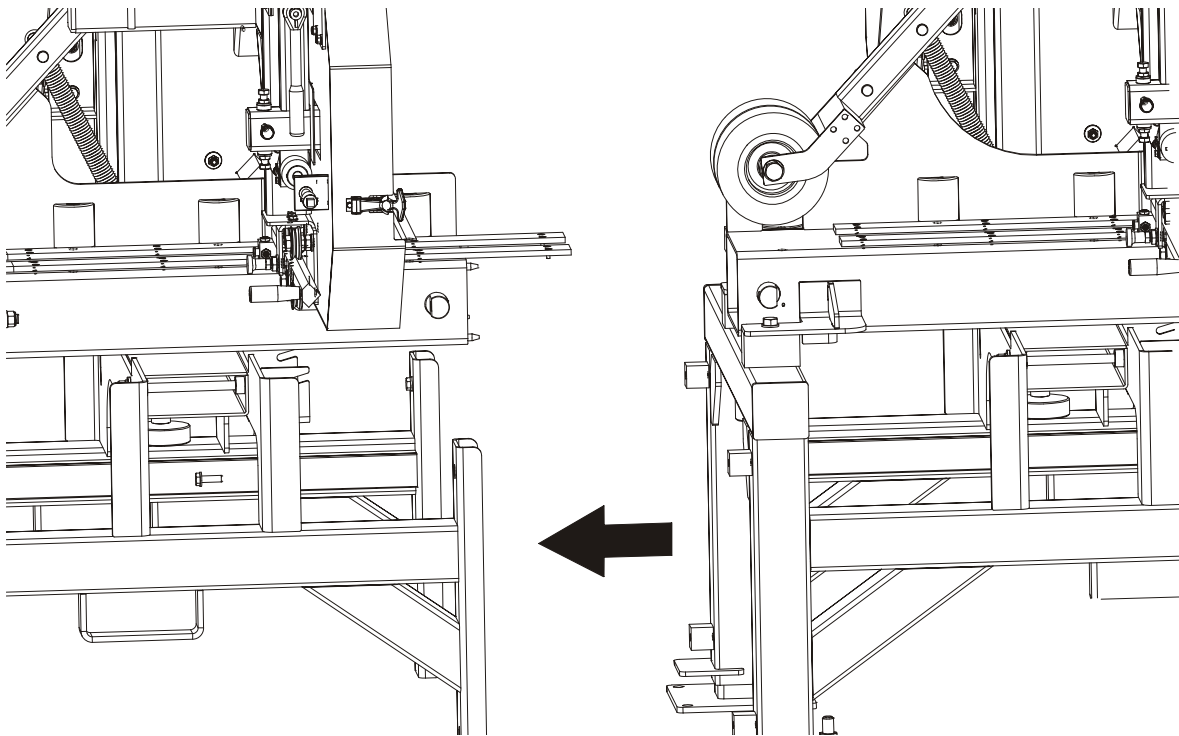

FIG. 2-2

See **Figure 2-3**. Using the appropriate bolts, washers and nuts, mount the base and the

additional module (modules) together.

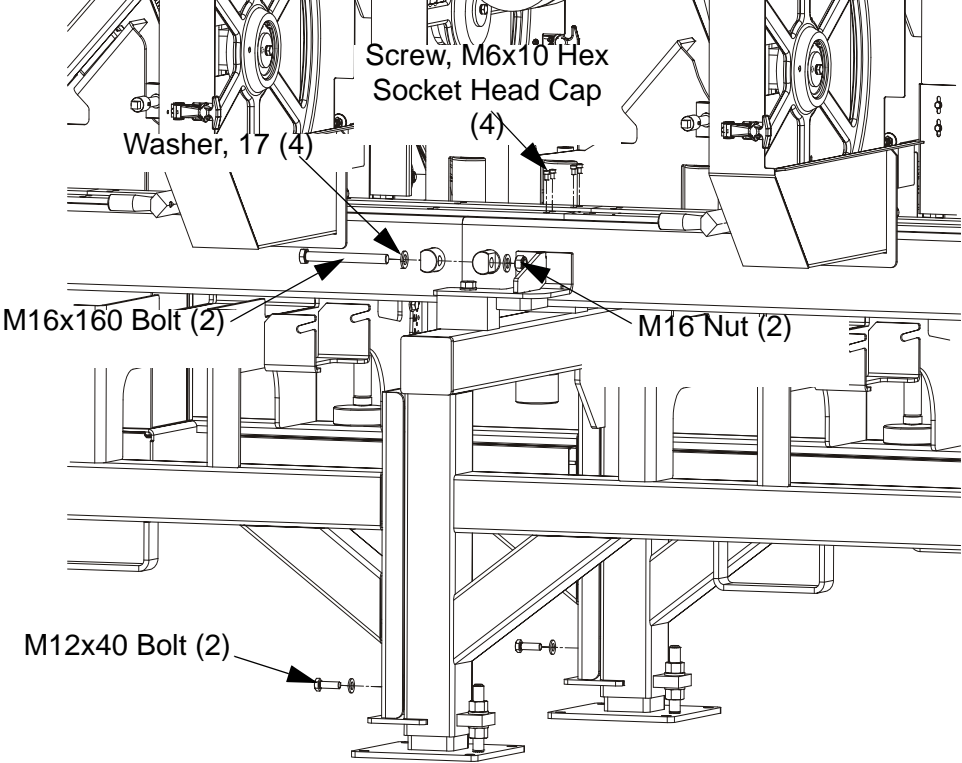

FIG. 2-3

2 Operation

Resaw Setup

See Figure 2-4. Mount the feed chain drive module.

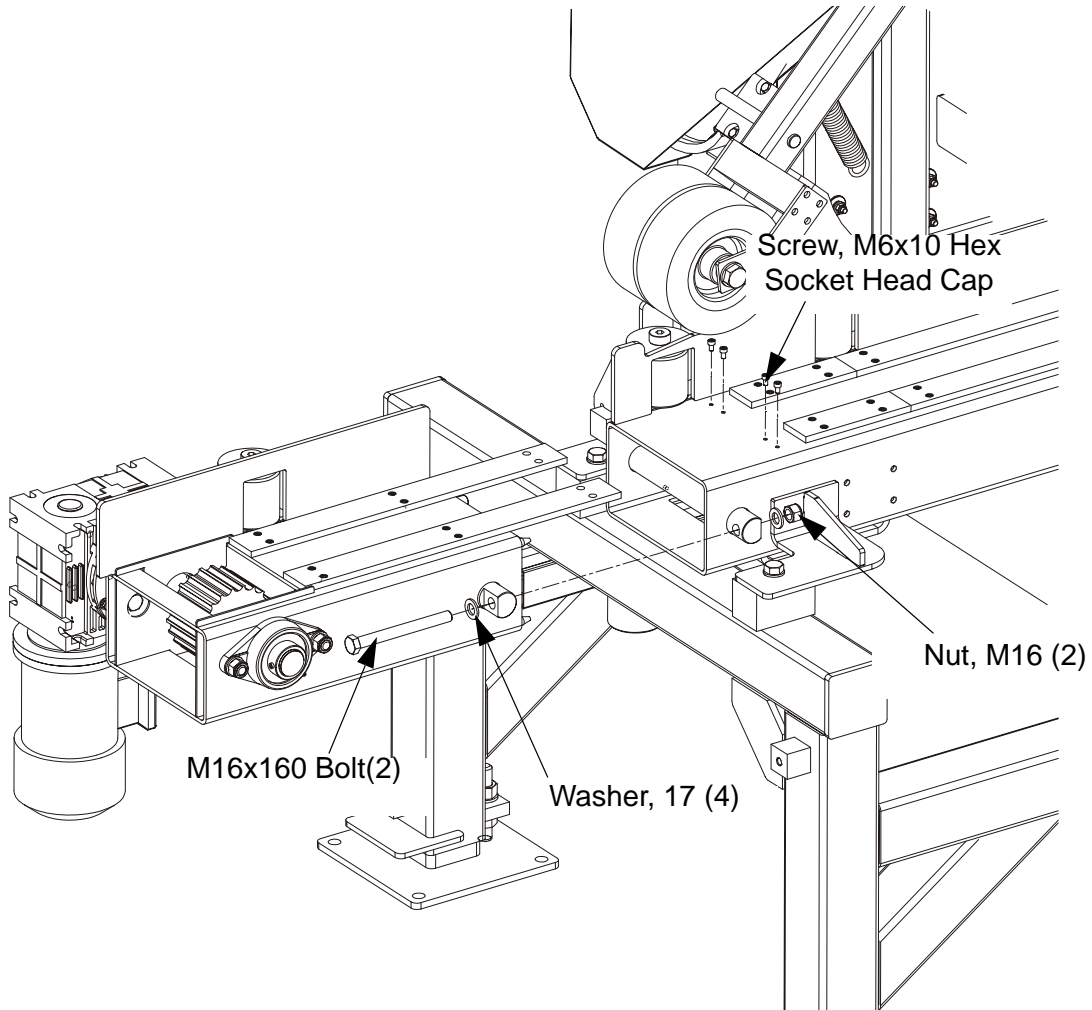

FIG. 2-4

See Figure 2-5. Mount the feed chain and apply proper tension. [See Section 3.9](#)

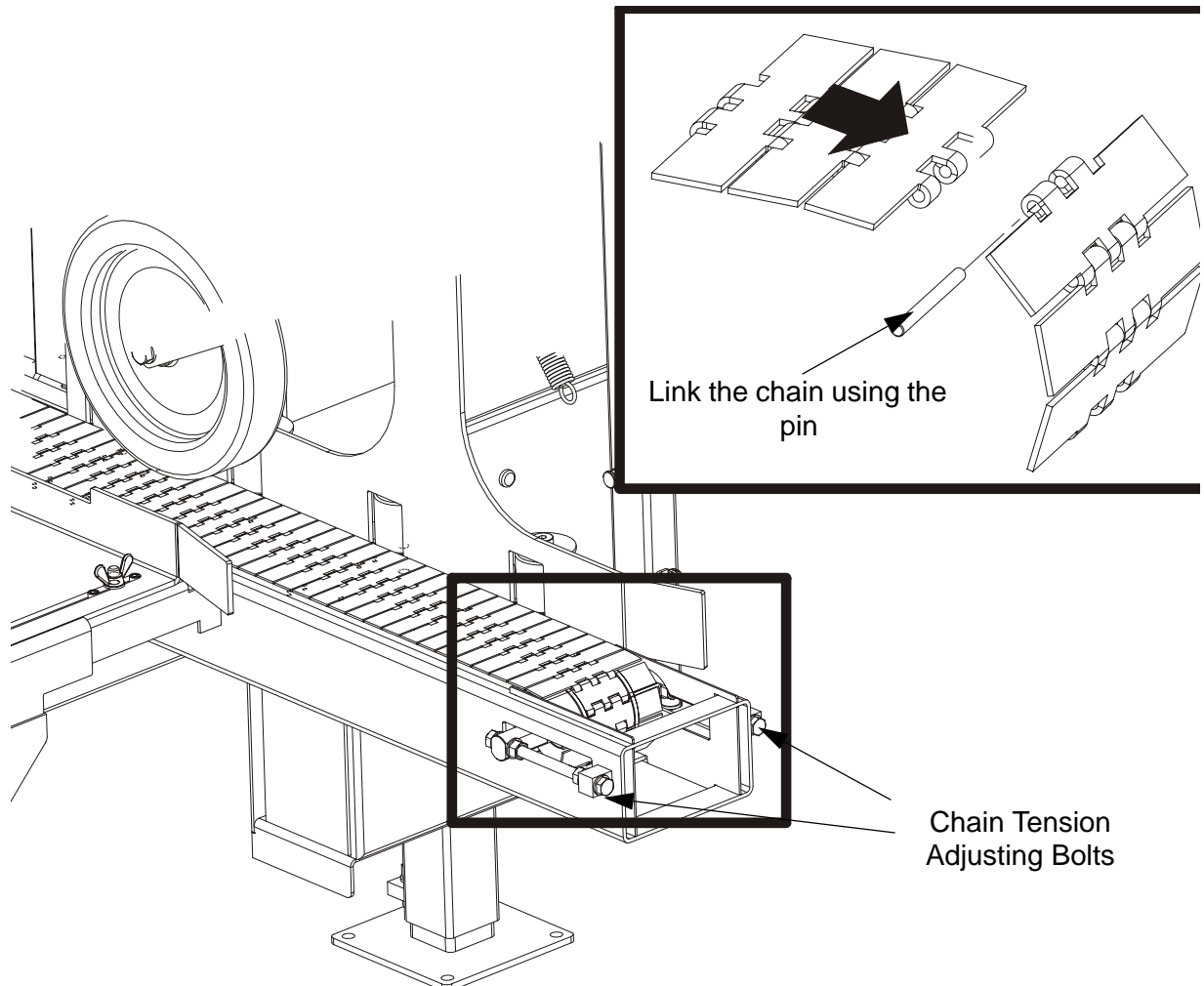

FIG. 2-5



IMPORTANT! If using the HR resaw with return tables before starting to use move the control panel and rear e-stop to the locations shown on the figures from 2-6 to 2-11 (depending on resaw configuration).



IMPORTANT! Before starting to use the resaw you have to meet the following conditions:

- Set up the resaw on firm and level ground.
- The resaw can be operated with the sawdust collection system only.
- The resaw can be operated under roof only.

2 Operation

Resaw Setup

- The resaw can be operated in temperature range from 5° C to 40° C only.
- Have a qualified electrician install the power supply (according to EN 60204 Standard). The power supply must meet the specifications given in the table below.

See Table 2-1. Depending on the number of saw heads, you should use different circuit breakers and power cord cross sections. See the table below for the required connection specifications.

Number of saw heads	Circuit Breaker [A]	Power Cord Cross Section [mm ²]
2	45	6
4	86	16
6	128	25

TABLE 2-1

- All possible HR resaw and return tables configurations, operator's positions and E-STOP locations are shown on the figures below.

See Figure 2-6. Layout of the MRTHR6-M (HR 6-heads, for logs 1.5m-3.6m)

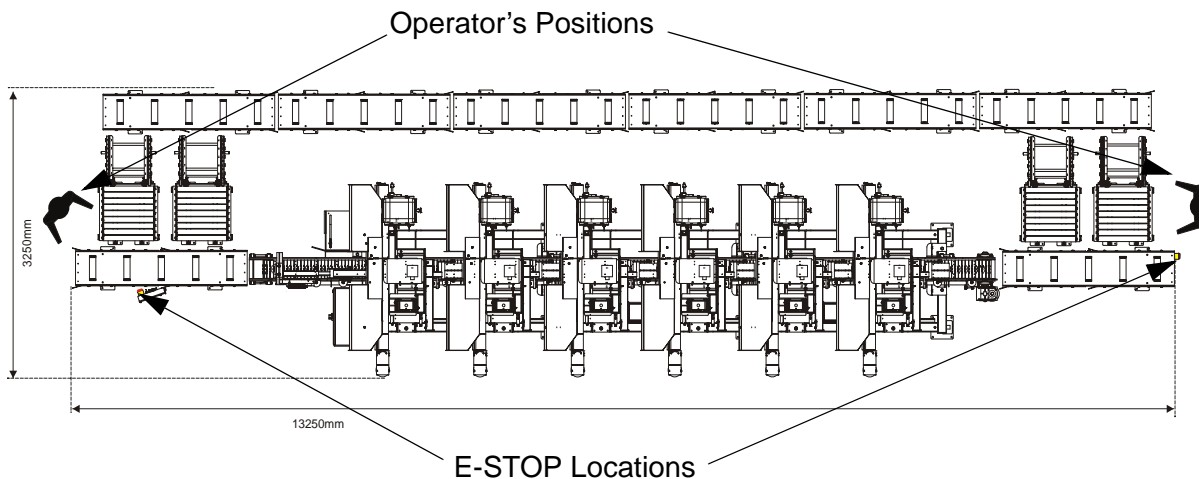

FIG. 2-6

See Figure 2-7. Layout of the MRTHR6-S (HR 6-heads, for logs <1.5m)

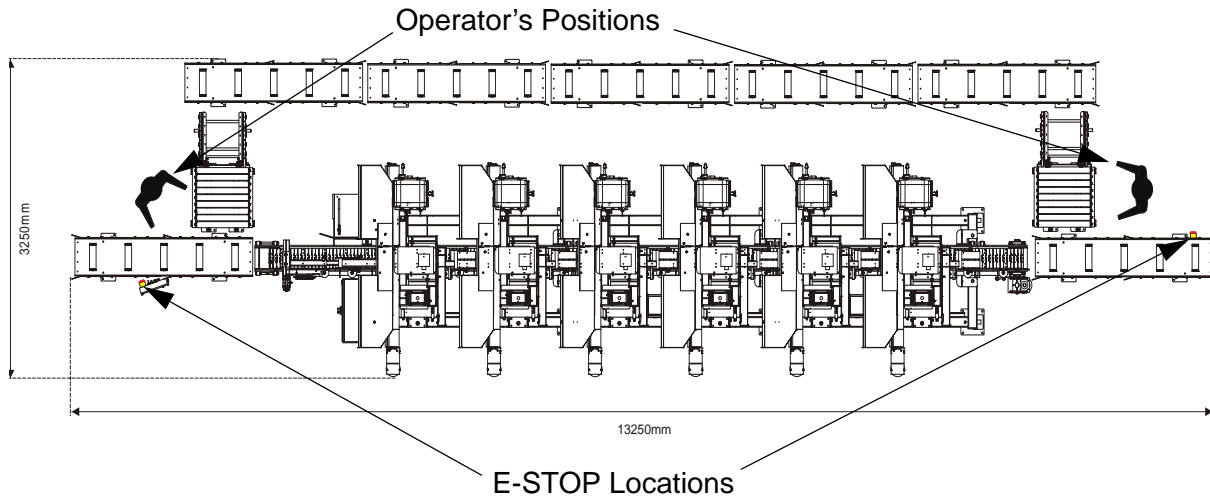

FIG. 2-7

See Figure 2-8. Layout of the MRTHR4-M (HR 4-heads, for logs 1.5m-3.6m)

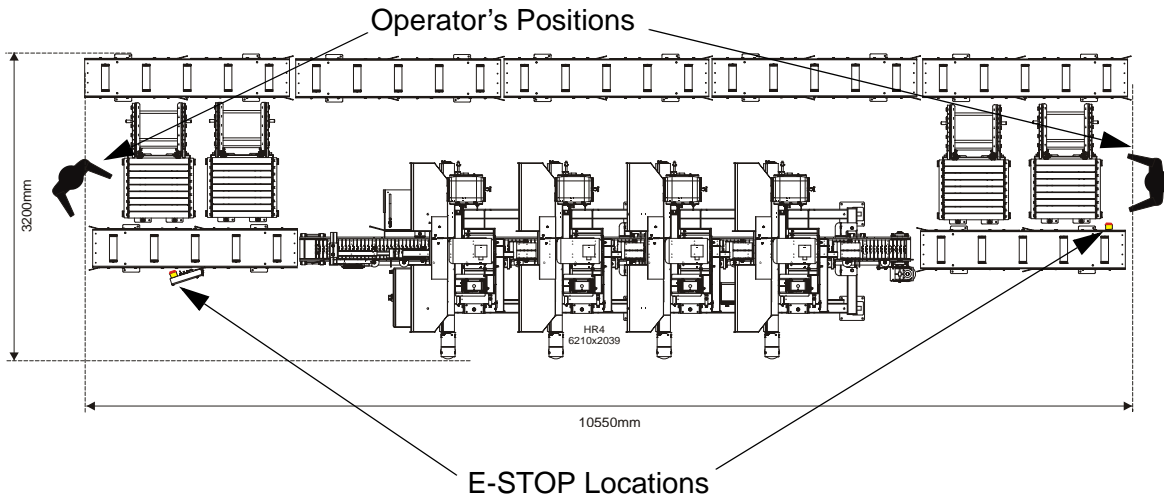

FIG. 2-8

2 Operation Resaw Setup

See Figure 2-9. Layout of the MRTHR4-S (HR 4-heads, for logs <1.5m)

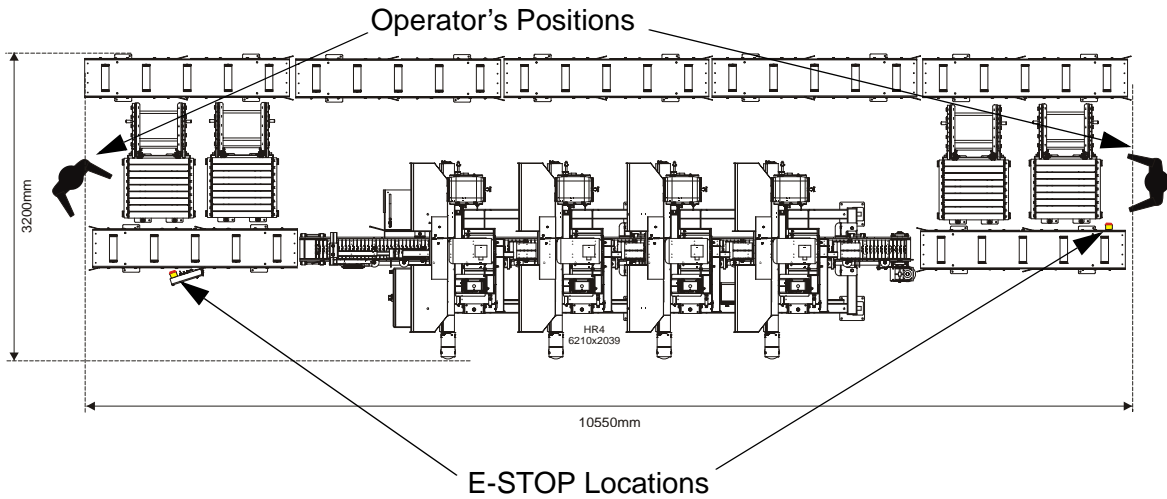

FIG. 2-9

See Figure 2-10. Layout of the MRTHR2-M (HR 2-heads, for logs 1.5m-3.6m)

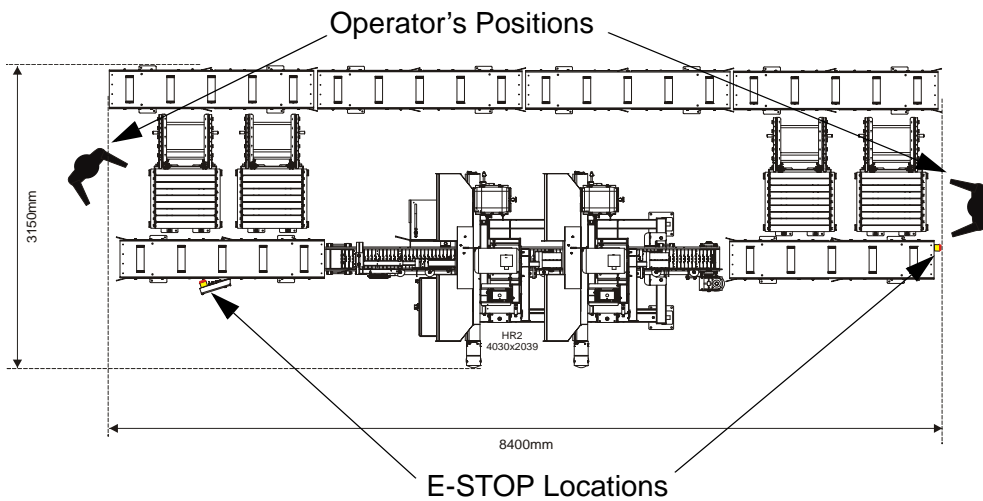

FIG. 2-10

See Figure 2-11. Layout of the MRTHR2-S (HR 2-heads, for logs <1.5m)

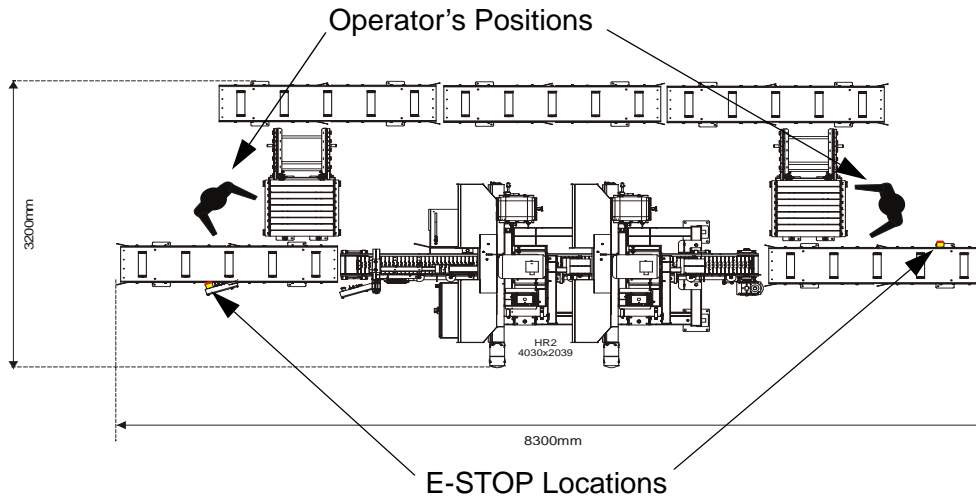

FIG. 2-11



IMPORTANT! When starting the machine for the first time, check that the main motor rotation direction is as indicated by the arrow located on the motor body (fan guard). If the rotation direction is incorrect, invert the phases in the phase inverter located in the power socket (electric box). Setting the phases in the phase inverter correctly will ensure correct rotation directions of all sawmill motors.

- The resaw can be lifted using a forklift only. The forklift must be rated for at least 2000kg. The resaw is equipped with forklift pockets. Insert the forks into the pockets

2 Operation *Resaw Setup*

shown on the picture below.

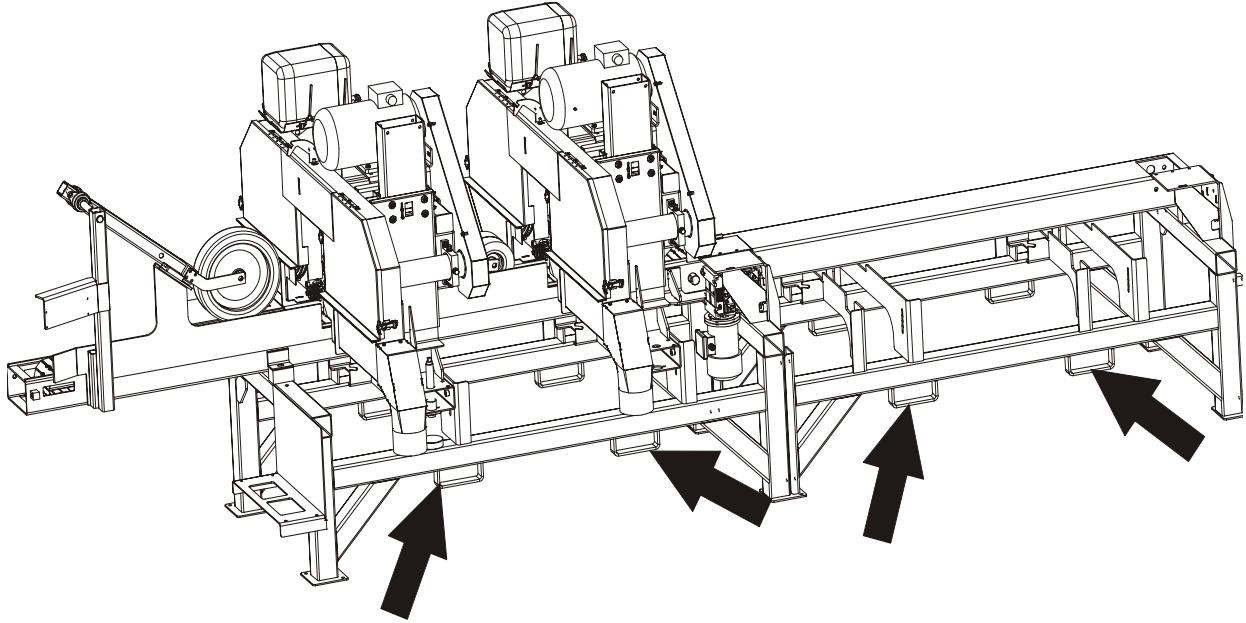

FIG. 2-12

2.3 Replacing The Blade



DANGER! Always shut off the resaw motor before changing the blade. Failure to do so may result in serious injury.



WARNING! Always wear gloves and eye protection whenever handling bandsaw blades. Changing blades is safest when done by one person! Keep all other persons away from work area when changing blades. Failure to do so may result in serious injury.

Raise the blade housing cover. Turn the blade tension handle to release the blade tension until the wheel is pulled in and the blade is lying loose in the blade housing. Lift the blade out of the blade housing.

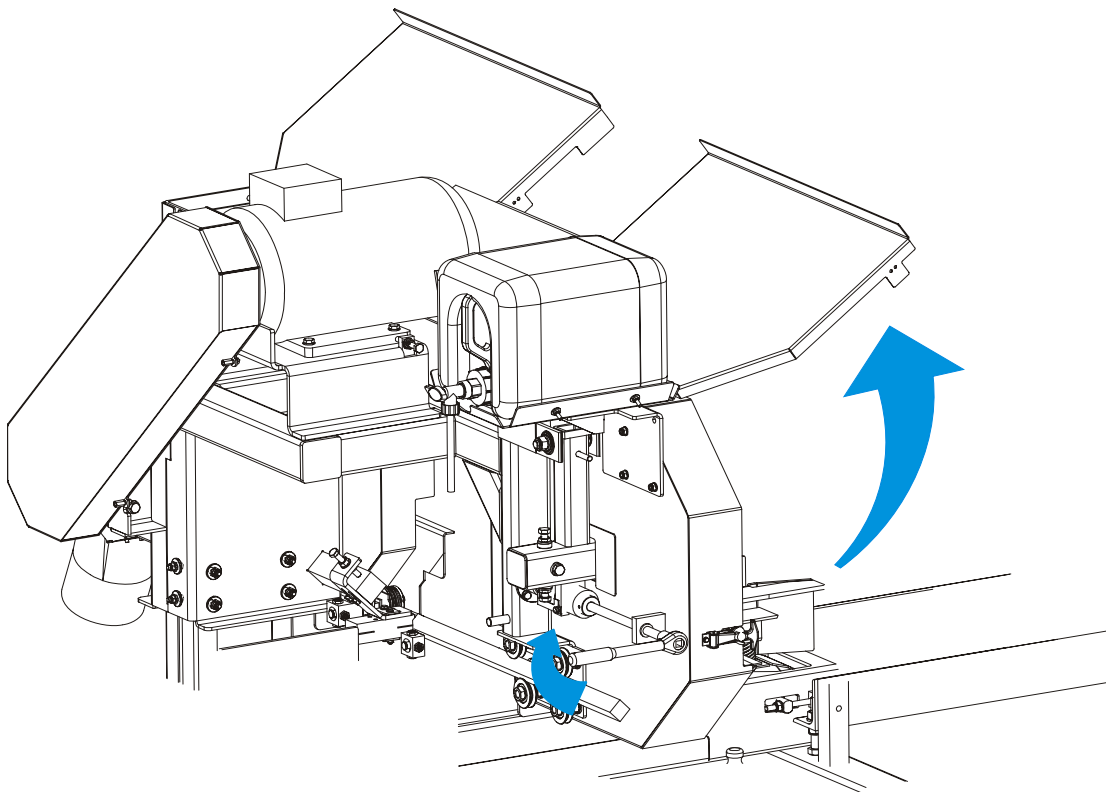

Install a new blade around the two blade wheels so that the teeth located between the blade guide assemblies point to the drive side of the machine. Make sure the teeth are pointing the correct direction.

Position 1 1/4" wide blades on the wheels so the gullet is 3.0 mm (\pm 1.0 mm) out from the front edge of the wheel.

2 Operation

Tensioning The Blade

Close the blade housing cover.

Next, tension the blade as described in the following instructions.

2.4 Tensioning The Blade

See **Figure 2-13**. Place the provided ratchet on the blade tensioner shaft. Turn the ratchet clockwise until the outside face of the rubber spring washer is even with the indicator (see the figure below). Check the blade tension occasionally when adjusting the cant control or while cutting and adjust if necessary. As the blade and belts heat up and stretch, the blade tension will change. Also, ambient temperature changes can cause tension to change.

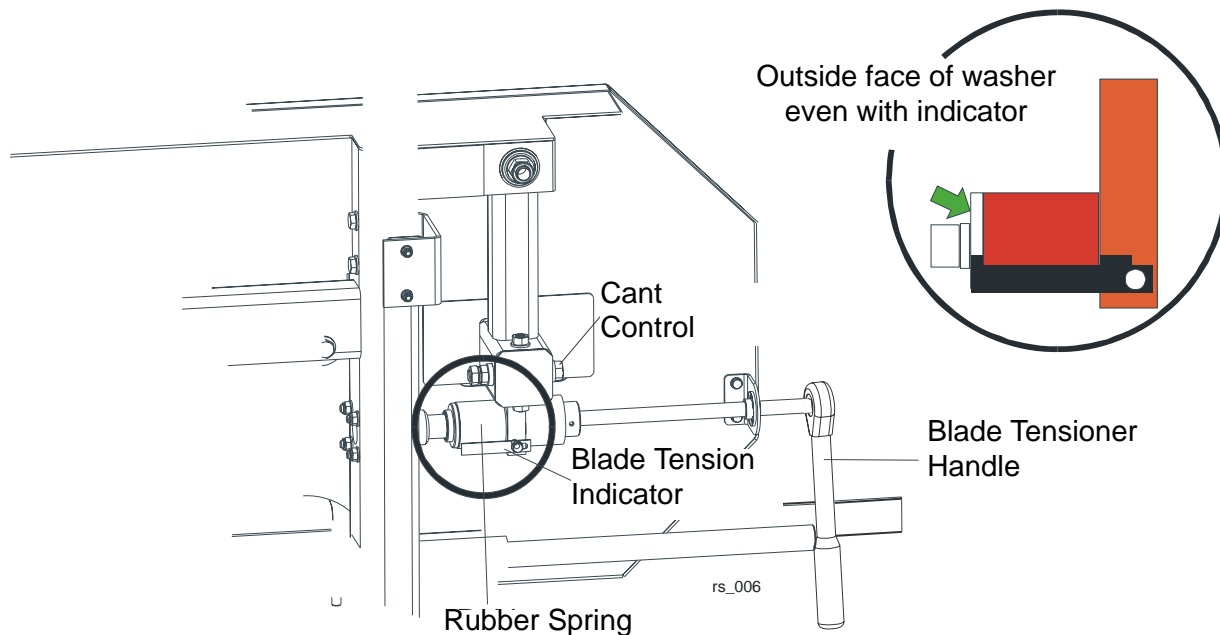

FIG. 2-13



CAUTION! Release the blade tension when the resaw is not in use.

2.5 Tracking The Blade

1. Open the blade housing cover.
2. Turn the key switch to the "H" position.



3. Manually spin one of the blade wheels until the blade positions itself on the blade wheels.
4. Check that the blade is properly positioned on the blade wheels.

See **Figure 2-14**. 1 1/4" wide blades should be placed on the blade wheels so that the

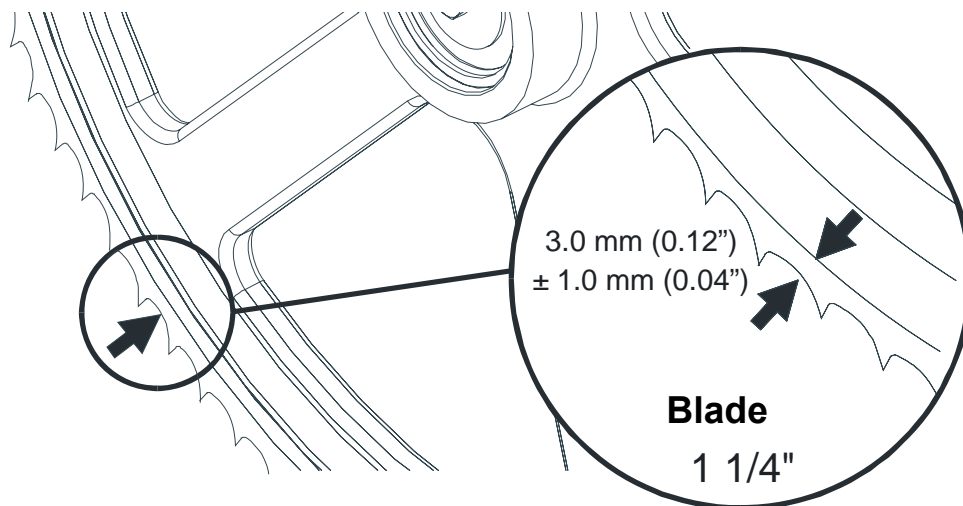

FIG. 2-14

gullet is 3.0 mm (0.12") \pm 1.0 mm (0.04") out from the front edge of the wheel.

5. Use the cant adjustment bolt, shown in **Figure 2-13**, to adjust where the blade travels on the blade wheels.

To move the blade out on the blade wheel, turn the cant adjustment bolt clockwise. To move the blade in on the blade wheel, turn the bolt counterclockwise.

6. Adjust the blade tension if necessary to compensate for any changes that may have occurred while adjusting the cant control.
7. Close the blade housing cover.



CAUTION! Make sure all guards and covers are in place and secured before operating or towing the resaw. Failure

to do so may result in serious injury. Be sure the blade housing cover is in place and secured.

NOTE: After aligning the blade on the wheels, always check the blade guide spacing and location.

2.6 Saw Height Adjustment

You can raise or lower each individual saw head to determine the thickness of the finished stock. The saw heads should be adjusted so that the last blade the material passes through is closest to the feed track.

Example: You want to cut cants into 12.5 mm pallet material. Assuming your Resaw has six cutting heads, you will need to adjust each head in 14.0 mm increments up from the feed track. This will allow 1.5 mm kerf for each blade.

See Figure 2-15. The sixth saw head (last one the material will pass through) should be adjusted to 12.5 mm above the feed track. The fifth head should be adjusted to 26.5 mm above the track, fourth head 40.5 mm, etc....

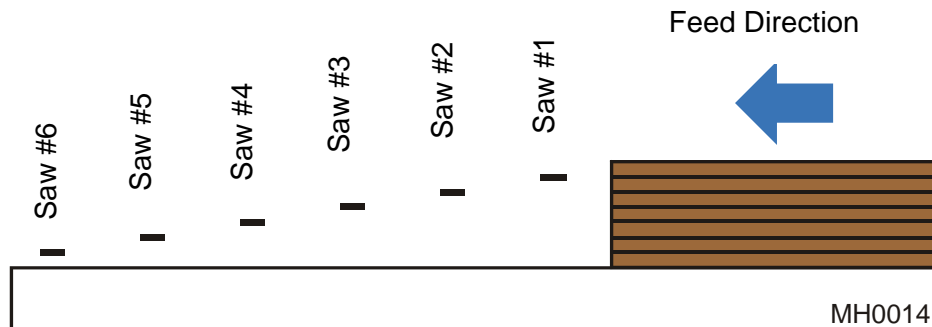

FIG. 2-15

1. Install a blade if needed and check for correct blade tension. ([See Section 2.4](#))
2. Set the saw head at the desired height. (The blade height scale shows the height of the blade above the feed track.)

See Figure 2-16. To raise or lower the saw head, use the acme screw as shown in the figure. Turn the screw clockwise to raise the saw head, counterclockwise to lower the saw

head.

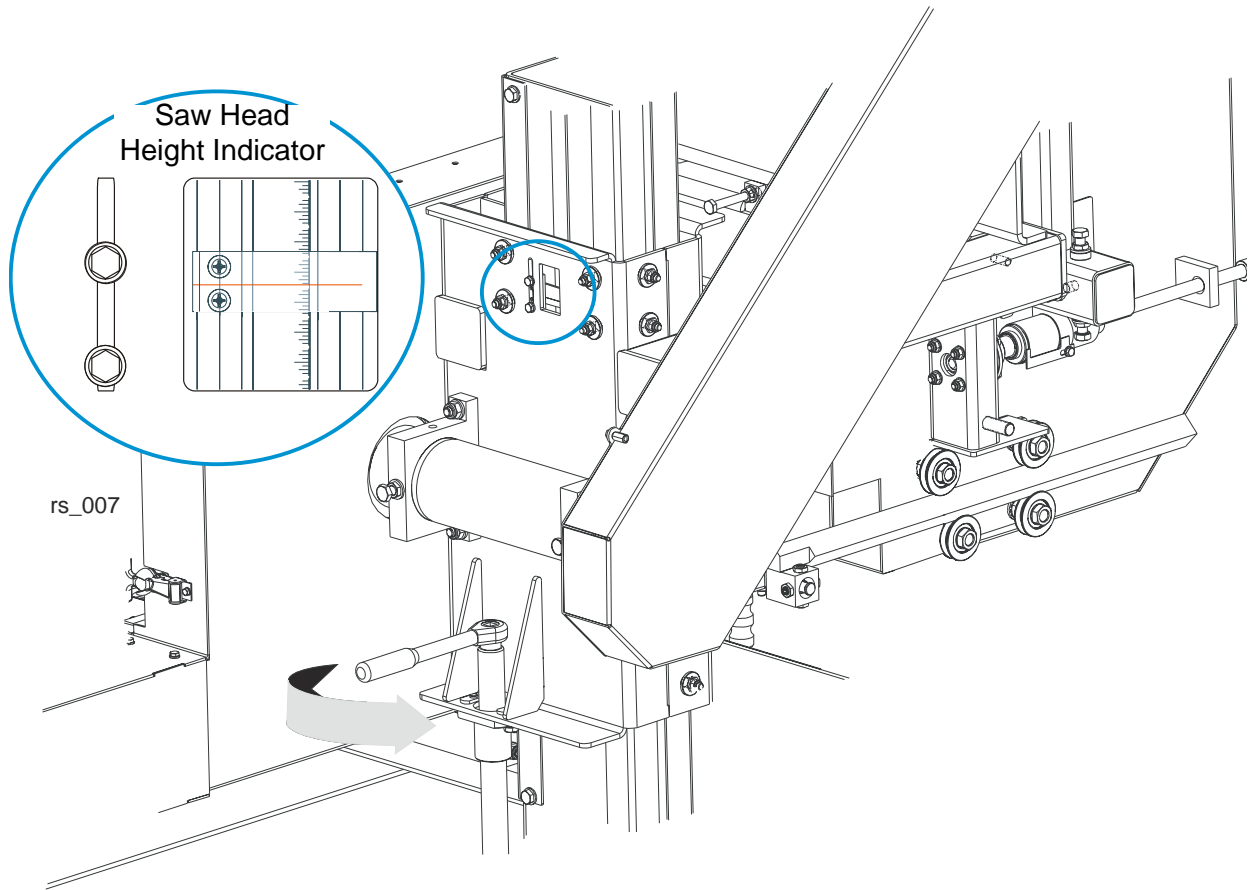

FIG. 2-16

NOTE: When adjusting the saw head height lower than 20mm, adjust blade guide arm so it doesn't touch the feed chain.

2

Operation Saw Height Adjustment

See Figure 2-17.

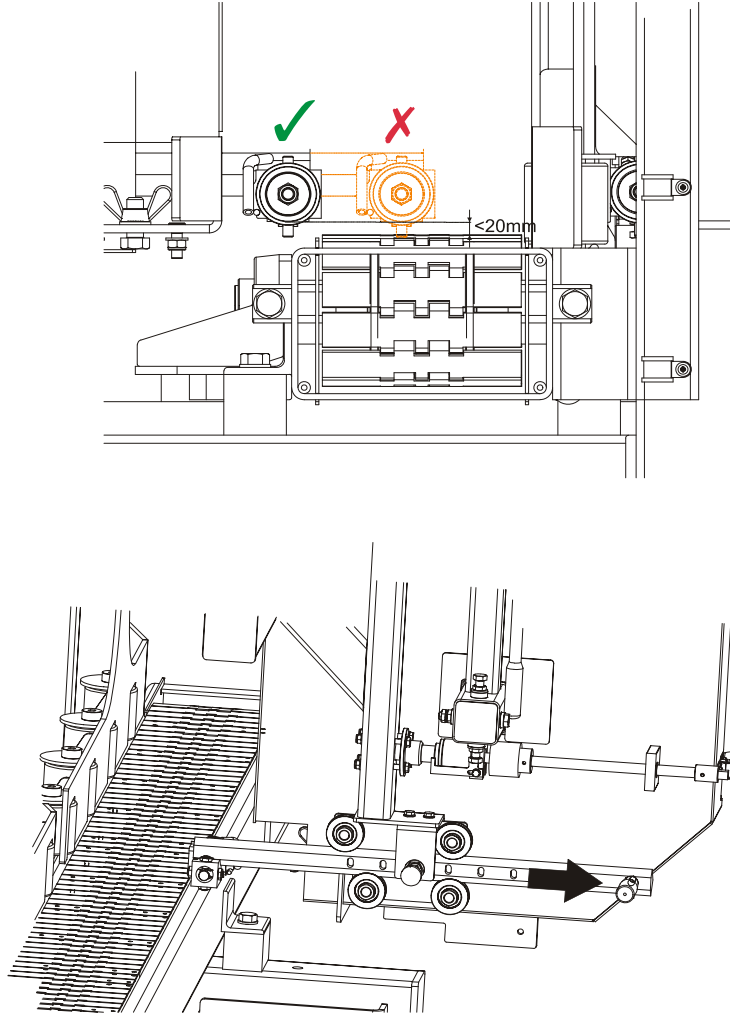

FIG. 2-17

2.7 Tilt

See **Figure 2-18**. The saw head may be tilted to produce siding. Loosen the locking bolt. Turn the tilt adjustment screw clockwise to tilt the saw head upward or counterclockwise to tilt the saw head downward.

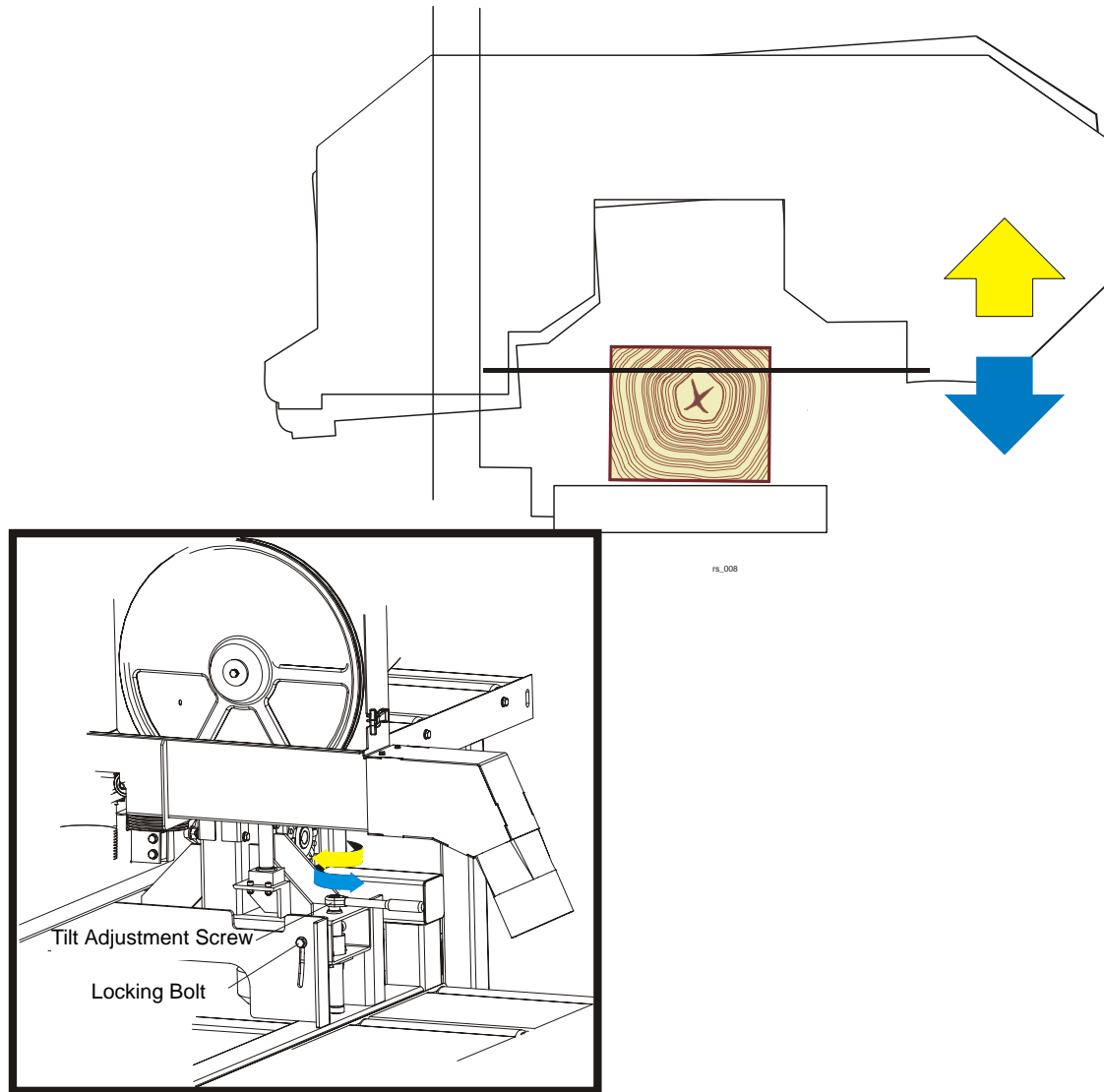

FIG. 2-18

NOTE: The saw head can be set at an angle ranging from 0° to 8°

2.8 Guide Fence Adjustment

Patrz rysunek 2-19. Loosen the wing nuts. Move the guide fence to the desired cant width.

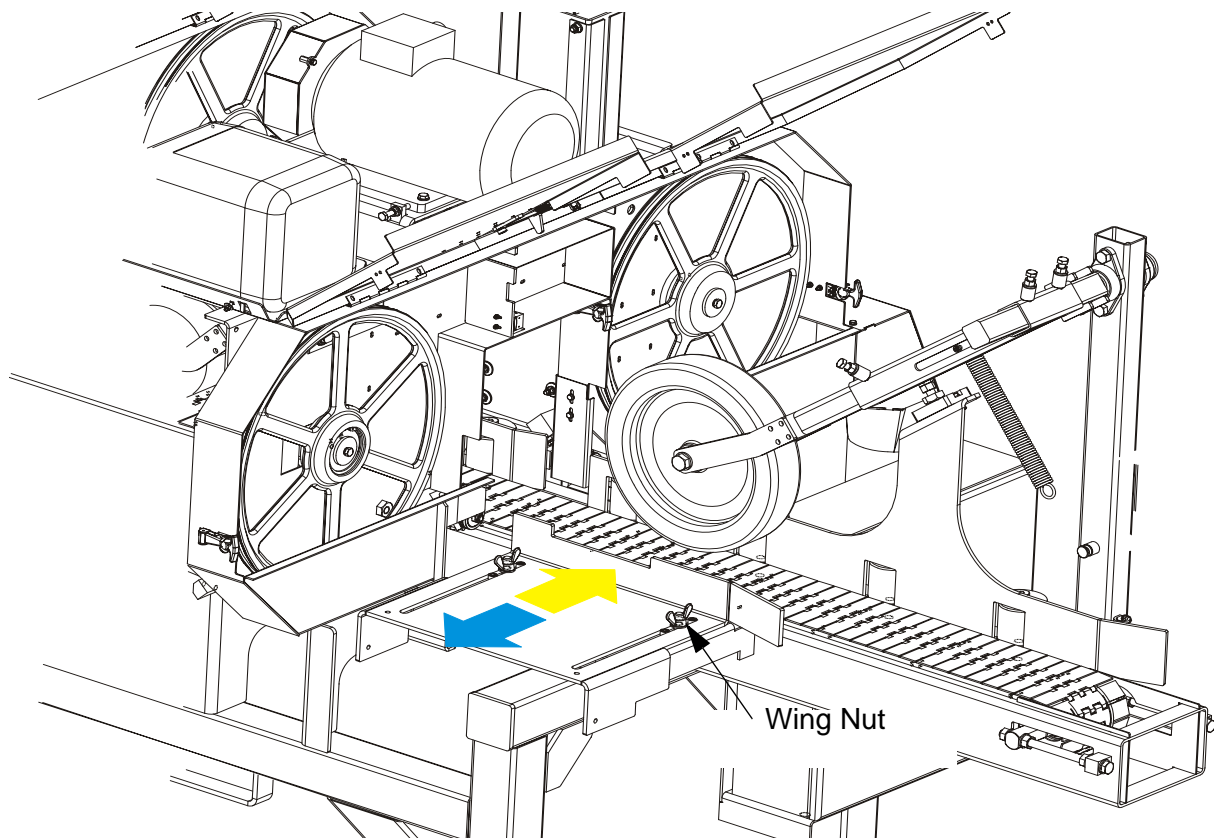

FIG. 2-19

2.9 Blade Guide Arm Adjustment

The outside blade guide arm can be adjusted in or out depending on the width of the material to be cut. The arm should be adjusted about 25 mm wider than the material to be cut.

Example: If the material to be cut is 150 mm wide, adjust the blade guide arm so the area between the blade guides is 175 mm wide.

See Figure 2-20. To move the blade guide arm, unlock the safety pin and slide the arm in or out. Lock the lock pin.

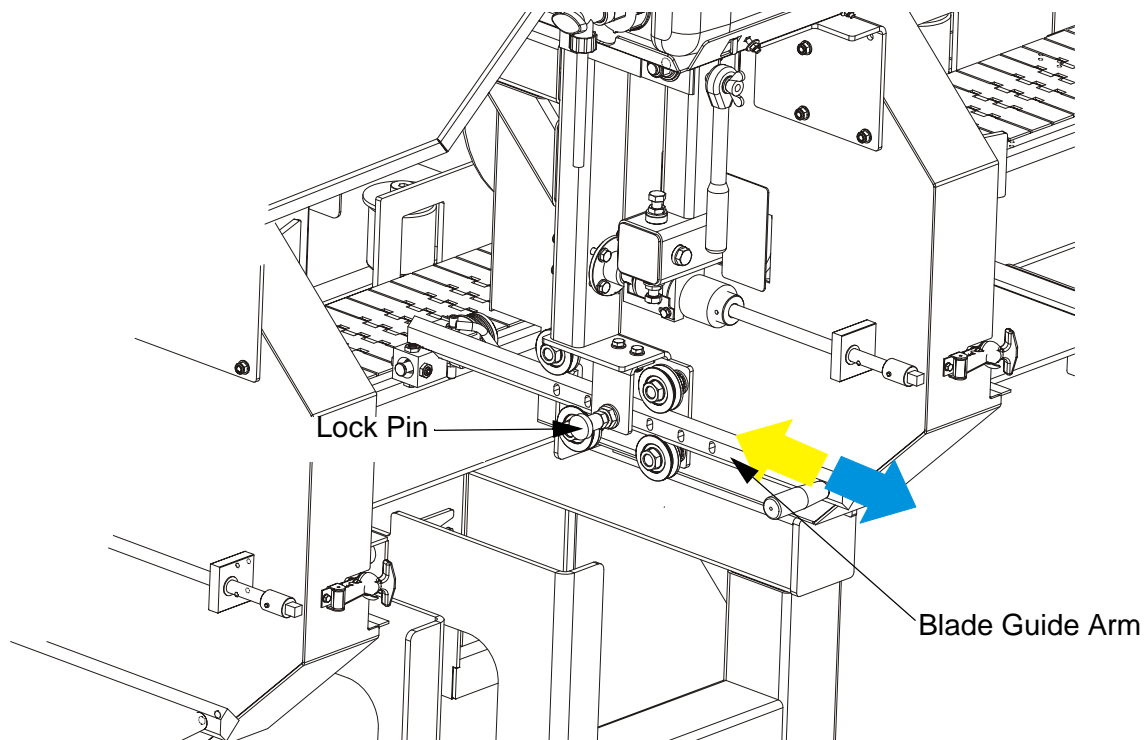



FIG. 2-20

2.10 Machine Start

 **DANGER!** Before starting the resaw, perform these steps to avoid injury and/or damage to the equipment:

- Close the blade housing cover and replace any guards removed for service.
- Check the feed track and remove all loose objects such as tools, wood, etc.
- Check that the blade is properly tensioned.
- Make sure all persons are at a safe distance from the machine.
- Check that the emergency stops are released.

NOTE: The resaw will not start if either of the emergency stops is on.

Before starting the saw heads, check that the main power switch servicing the resaw is on.

See Figure 2-21. Start the blade motors. To do this, turn the key switch to the  position and then press the START button on the control panel (see the figure below). The motors should start and the blades should start spinning.

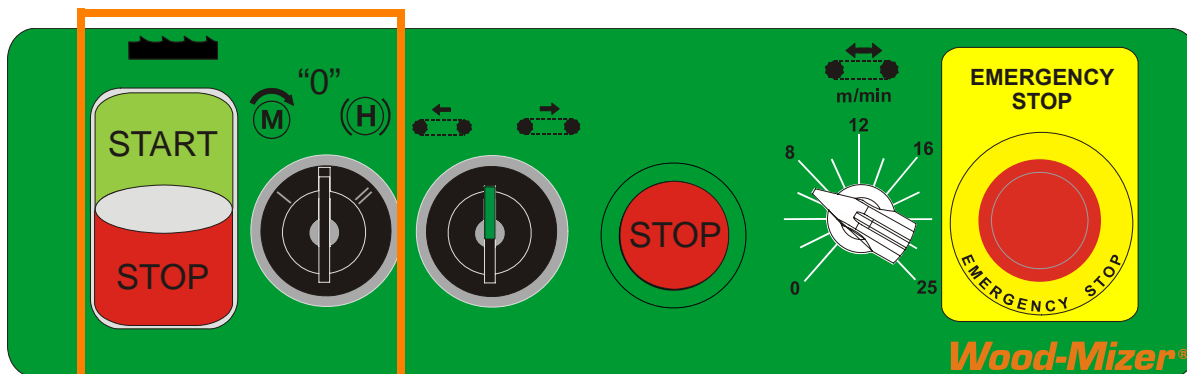

FIG. 2-21

To stop the blades motors, press the STOP button shown in the figure above. The blade motor also may be stopped by pushing either of the emergency stop buttons.

If either of the emergency stops has been used to stop the blade motor, rotate the switch clockwise before restarting the saw head. The saw head cannot be restarted until the emergency stop button is released.

See Figure 2-22. After the saw head has been successfully started, the feed track can be

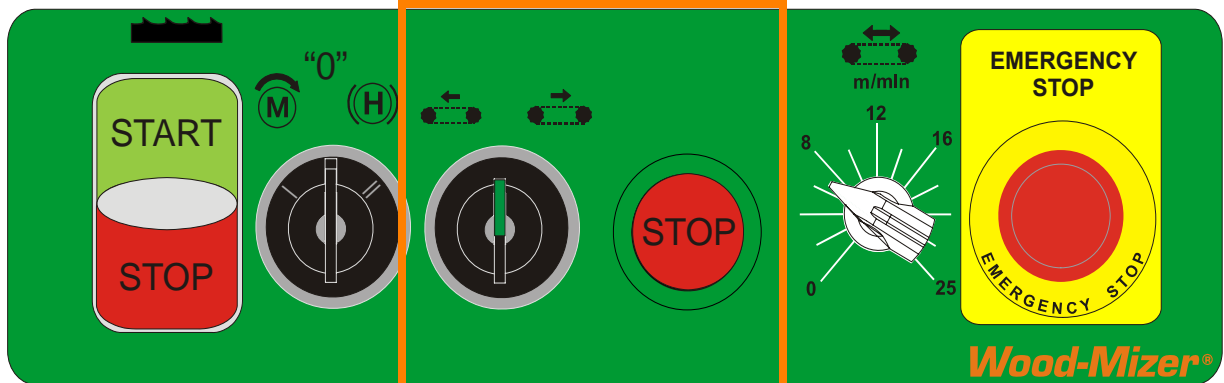

FIG. 2-22

started. To start the track feed forward, turn left the Track switch shown in Figure 2-5.

The feed track can be stopped either by pressing the STOP button, or one of the emergency stop buttons. The emergency stop will also stop the blade motor.

NOTE: The feed track cannot be started if the blade motor is not started.

2 Operation

Machine Start

See Figure 2-23. The speed at which the feed track moves is adjustable. The feed track

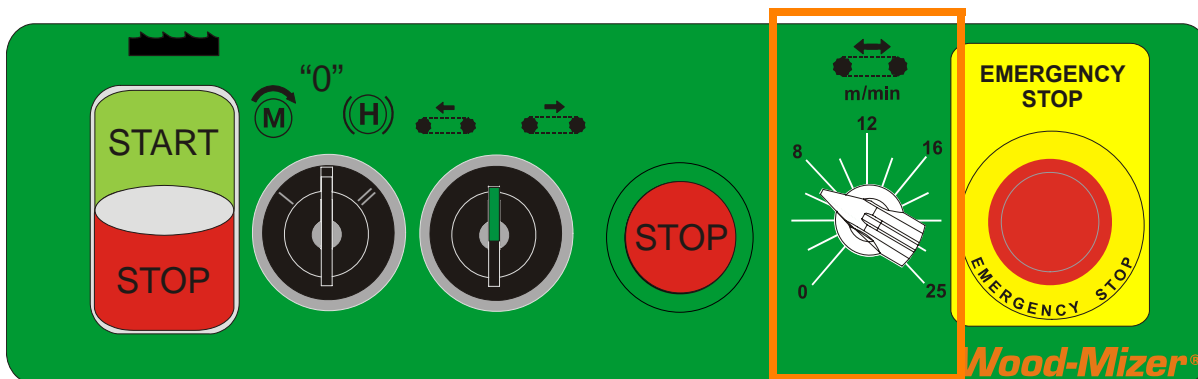

FIG. 2-23

speed switch, located on the control panel, allows the operator to adjust the feed rate from 0 to ca. 25 m per minute.

Turn the switch clockwise to increase the feed rate, counterclockwise to slow the feed rate down.

Factors that will determine what feed rate you can use include:

- Number of saw heads.
- Width of material to be cut. 200mm material will require a slower feed rate than 100mm material.
- Hardness of material to be cut. Some woods that are seasoned or naturally very hard will require slower feed rates.
- Sharpness of blades. Dull or improperly sharpened blades will require slower feed rates than sharp and properly maintained blades.
- Off-bearing capability. Your ability to feed end-to-end will also determine what feed rate you can use.

2.11 Water Lube Operation

See **Figure 2-24**. The Water Lube System keeps the blade clean. Water flows from a 5-gallon (18.9 liter) bottle through a hose to the blade guide where the blade enters the log. A valve in the bottle cap controls the amount of water flow.

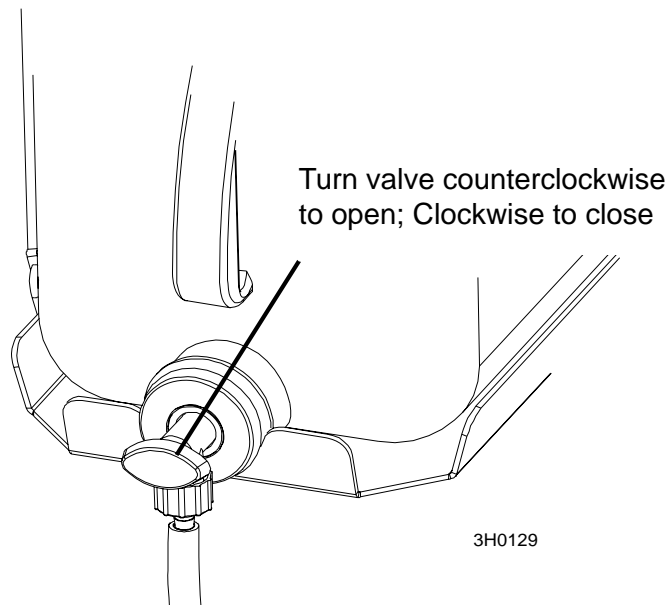



FIG. 2-24

Not all types of wood require the use of the Water Lube System. When it is needed, use just enough water to keep the blade clean. This saves water, and lowers the risk of staining the boards with water. Usual flow will be 1-2 gallons (3.8-7.6 liters) per hour (on average, the bottle content is sufficient for 4-hour-long cutting). A squirt of liquid dishwashing detergent in the water bottle will help clean the blade when cutting wood with a high sap content. Before you start cutting, check the water level in the bottle.

 **WARNING!** Use ONLY water with the water lube accessory. Never use flammable fuels or liquids. If these types of liquids are necessary to clean the blade, remove it and clean with a rag. Failure to do so may result in serious injury or death.

Before removing the blade, start the blade motor with the START button. Let the blade spin with water running on it for about 15 seconds. This will clean the blade of sap buildup. Wipe the blade dry with a rag before storing or sharpening.

If you are sawing in freezing temperatures, remove the water lube bottle from the resaw when done sawing and store it in a warm place. Blow any remaining water from the water lube hose.

2.12 Operation Procedure

1. Install a blade if necessary.



WARNING! Always wear gloves and eye protection when handling bandsaw blades. Changing blades is safest when done by one person! Keep all other persons away from area when coiling, carrying or changing a blade. Failure to do so may result in serious injury.

2. Close the blade housing cover.
3. Tension the blade as described in [See Section 2.4.](#)
4. Spin the blade wheel by hand.



WARNING! Use extreme caution when spinning the blade wheel by hand. Make sure hands are clear of blade and wheel spokes before spinning. Failure to do so may result in serious injury.

5. Check alignment of the blade on the blade wheels and blade guides. Adjust as necessary.
6. Raise or lower the saw heads to the desired setting.



DANGER! Make sure all guards and covers are in place and secured before operating the resaw. Failure to do so may result in serious injury.

7. Start the blade motor.
8. Perform pre-start check (blade motors rotation direction).
9. Using the feed track speed switch, set the feed rate as desired.



DANGER! Always be sure all persons are out of the path of the blade before starting the motor. Failure to do so will result in serious injury.



WARNING! Always wear eye, ear, respiration and foot protection when operating or servicing your resaw.

10. Place the test material on the feed track and start the feed track.



DANGER! Always be aware of and take proper protective measures against rotating shafts, pulleys, fans, etc. Always stay a safe distance from rotating members and make sure that loose clothing or long hair does not engage rotating members resulting in possible injury.

11. Shut off the blade and feed track. Measure the finished material and adjust the saw heads up or down as necessary. Repeat with the test material until the desired finished dimension is obtained.
12. Restart the blade and feed track.
13. Place material on the infeed table. Return unfinished material to be re-fed into the resaw, i.e. place it on the return table.
14. Monitor blade tension as operation continues. Adjust blade tension if required.
15. If material jam occurs, stop the blades motors and feed track.



WARNING! Allow blade to come to a complete stop before servicing. Failure to do so will result in serious injury.

16. After operation is complete, shut off the blade motor and feed track.
17. Release blade tension if done sawing for the day.



CAUTION! Remove tension from the blade when the resaw is not in use.

SECTION 3 MAINTENANCE

This section lists the maintenance procedures that need to be performed.



This symbol identifies the interval (hours of operation) at which each maintenance procedure should be performed.

Be sure to refer to the motor manual for maintenance procedures concerning the blade motor.

3.1 Wear Life

See Table 3-1. This chart lists estimated life expectancy of common replacement parts if proper maintenance and operation procedures are followed. Due to the many variables which exist during resaw operation, actual part life may vary significantly. This information is provided so that you may plan ahead in ordering replacement parts.

Part Description	Estimated Life
B57 Blade Wheel Belts	500 hours
Blade Guide Rollers	1000 hours
Drive Belt	1250 hours

TABLE 3-1

3.2 Blade Guides

1. Check the rollers for performance and wear every blade change. Make sure the rollers are clean and spinning freely. If not, rebuild them. Replace any rollers which have worn smooth or have become cone shaped. See the Parts manual for blade guide rebuild kits and complete roller assemblies.

3.3 Sawdust Removal

1. Remove the excess sawdust from the blade wheel housing and sawdust chute every blade change.

3.4 Vertical Mast



Clean the vertical mast angles, wipe them dry and lubricate with a WD40 oil every 50 hours of operation.



CAUTION! Never use grease on the mast angles as it will collect sawdust.

3.5 Miscellaneous Lubrication

1. Apply a thin film of a lithium grease to the blade guide arm to help prevent it from rusting.
50
2. Lubricate the feed track chain with an easily penetrating oil such as WD-40.
50



CAUTION! Never apply grease to the feed track chain.
It causes sawdust buildup in chain links.

3. Make sure all safety warning decals are readable. Remove sawdust and dirt. Replace any damaged or unreadable decals immediately. Order decals from your Customer Service Representative.
4. Lubricate the acme screws (screws for saw head tilting and raising or lowering) with a lithium grease every 50 hours of operation.
50

3.6 Blade Tensioner

1. Grease the screw on the blade tensioner shaft with a lithium grease every fifty hours of operation, but at least once a week.

See Figure 3-1.

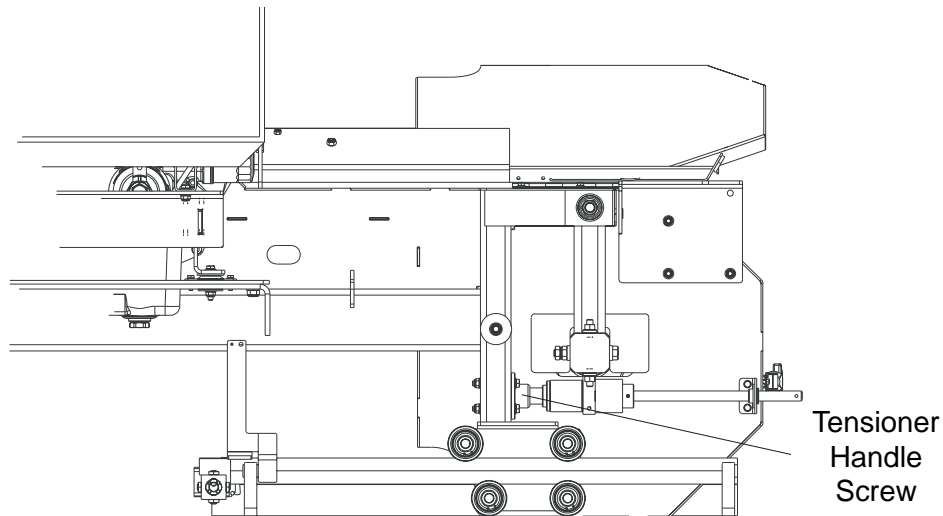

20_006

FIG. 3-1

3.7 Belts

1. Check the blade wheel belts for wear every 50 hours of operation. Replace as needed.
2. Periodically check all belts for wear. Replace any damaged or worn belts as needed.

3.8 Drive Belt Adjustment

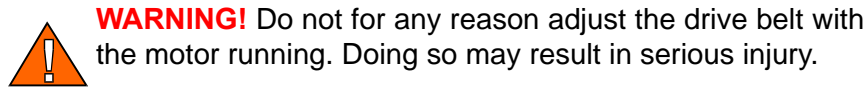

See **Table 3-2**. Check the drive belt tension after the first 20 hours, and every 50 hours thereafter. See the table below for drive belt tension specifications for your resaw.

50

Motor	Belt Tension
E11, E15	7/16" (11mm) deflection with 16 lbs. (7.2 KG) of deflection force

TABLE 3-2

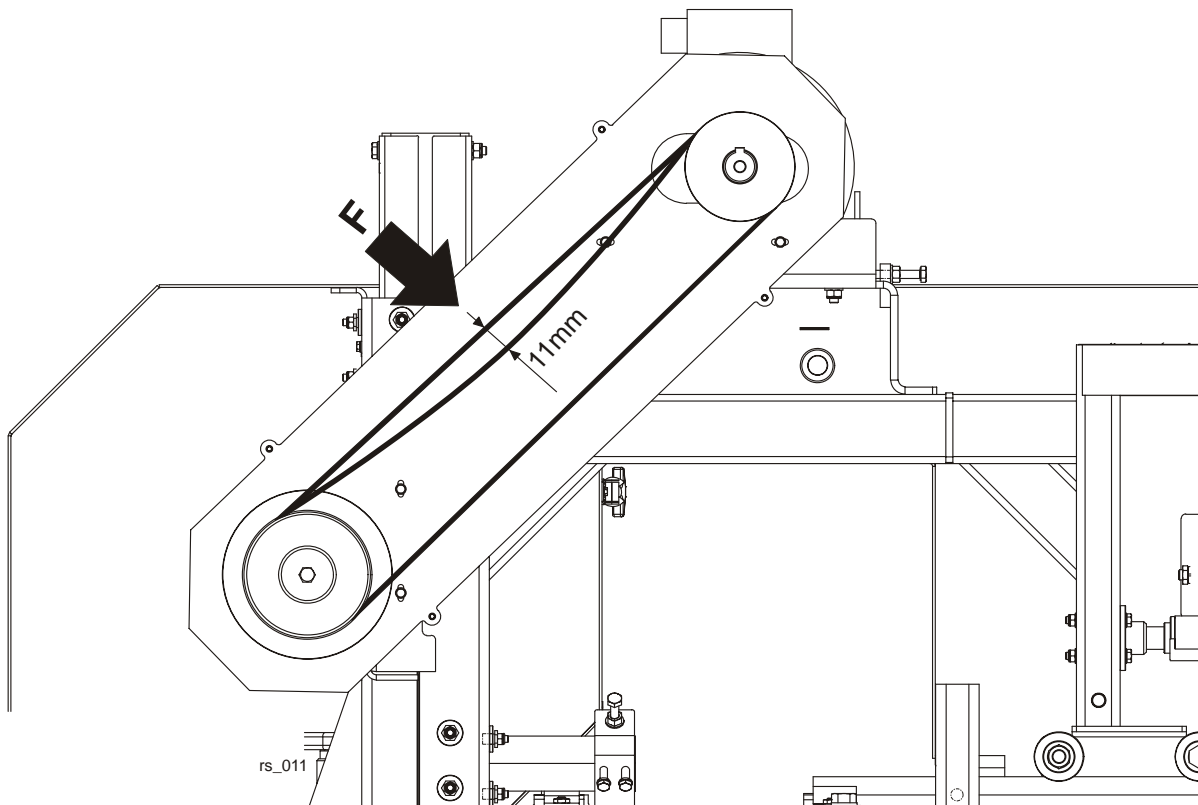

FIG. 3-2

To adjust the drive belt tension:

1. Remove the drive belt guard.
2. Loosen the four motor mounting bolts (see Figure 3-3).
3. Loosen one of the adjustment bolts, shown in Figure 3-3, and turn the other until the belt has proper deflection. (To increase the belt tension, you must loosen the right bolt and turn appropriately the left one.) **NOTE:** Be sure to adjust the bolts evenly so the motor remains in alignment.

4. Tighten the four motor mounting bolts.

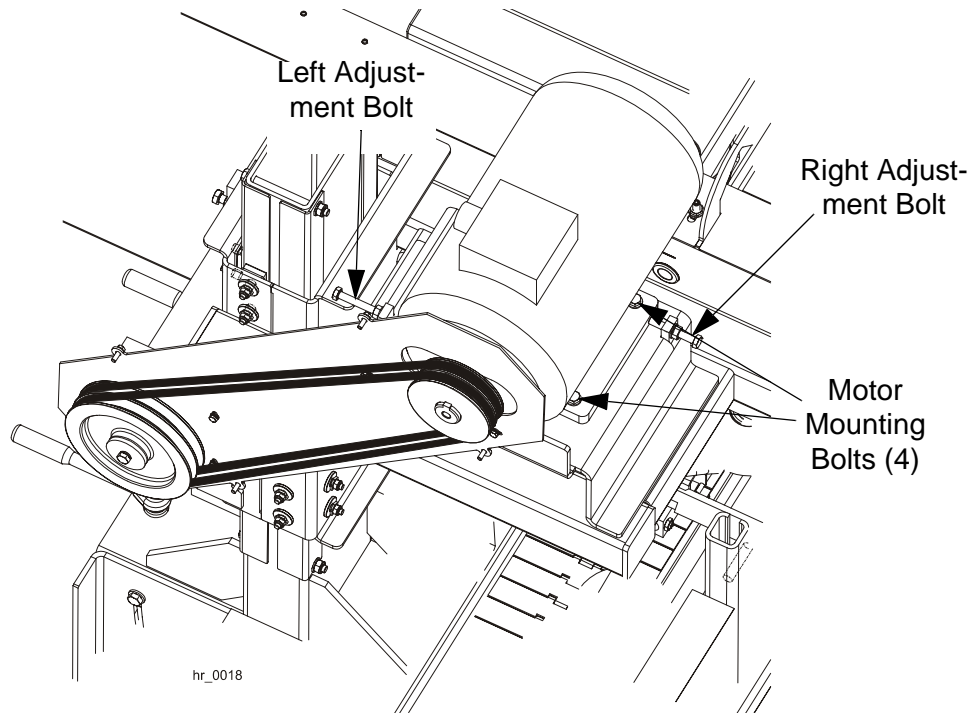

FIG. 3-3



Periodically check the belt for wear. Replace if damaged or worn.

See Figure 3-4. Keep the motor and drive pulleys aligned to prevent premature belt wear. To align the motor pulley to the drive pulley, loosen the set screw in the motor pulley groove and slide the motor pulley on the shaft until it is in line with the drive pulley.

After performing the alignment, make sure the drive belt tension has not been changed.

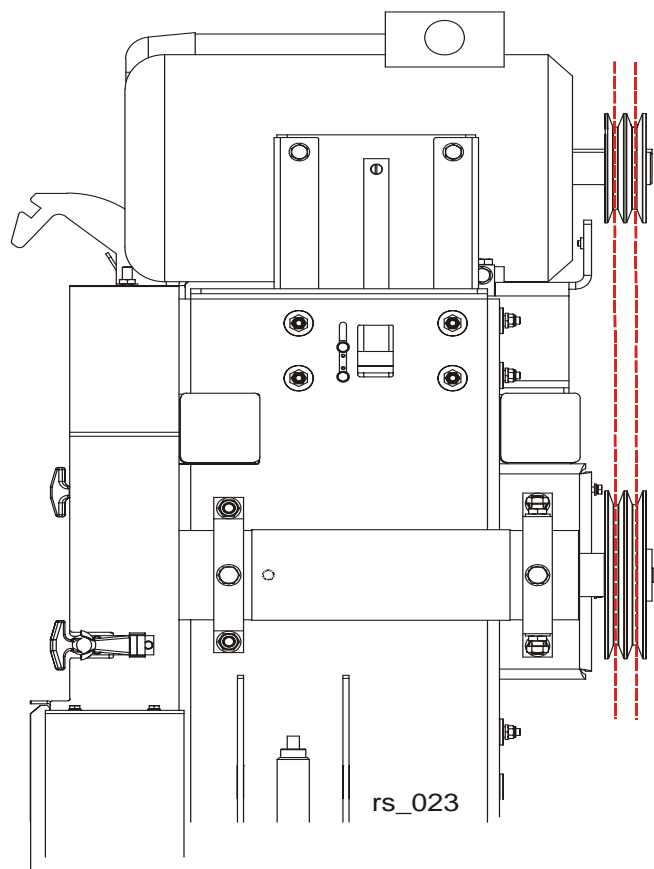

FIG. 3-4

3.9 Feed Track Chain Tension

See **Figure 3-5**. If necessary, use the adjustment bolts shown below to adjust the feed track chain tension. **NOTE:** The bolts must be adjusted evenly.

See **Figure 3-6**.

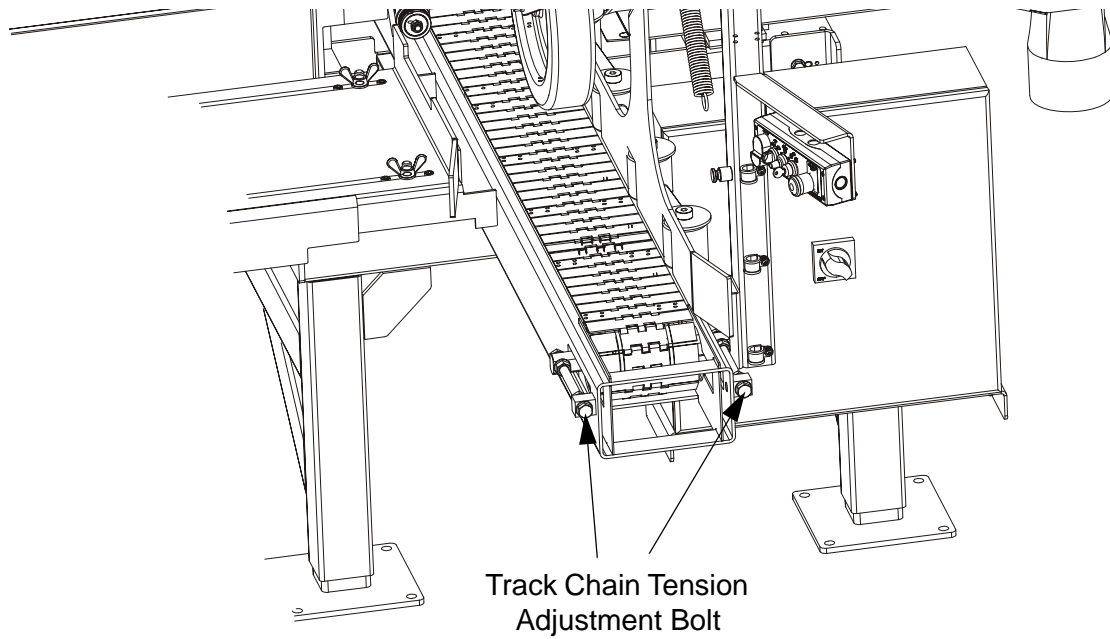

FIG. 3-6

3.10 Up/Down System

1. Lubricate the two acme screws, shown below, with a lithium grease every fifty hours of operation, but at least once a week.

50

See Figure 3-7.

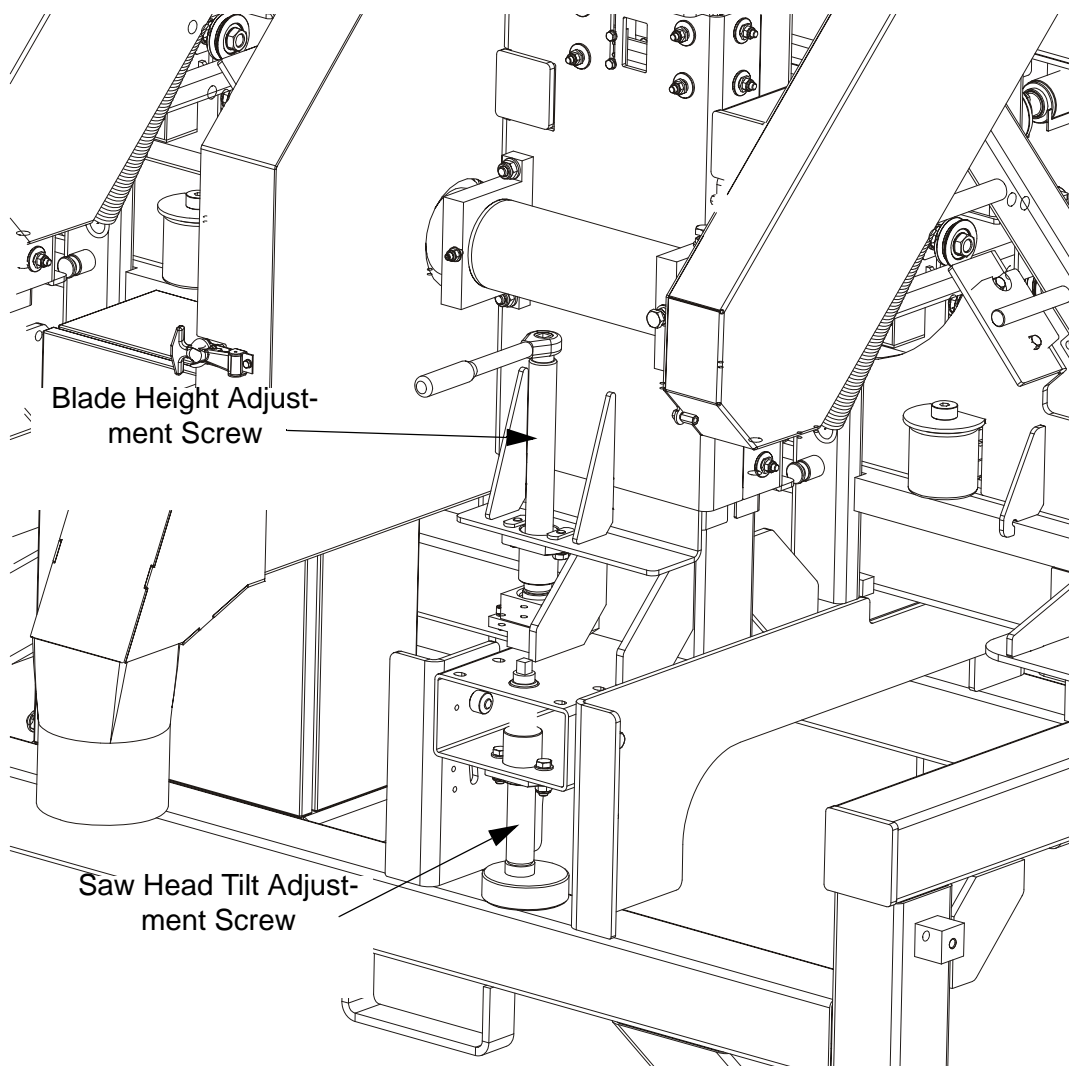

FIG. 3-7

SECTION 4 ALIGNMENT

4.1 Alignment Procedures

The Wood-Mizer resaw is factory aligned. This section includes instructions on how to realign the resaw completely. Be scrupulous when performing all alignment steps as resaw alignment determines the accuracy of your cuts. The alignment procedure should be performed approximately every 1500 hours of operation.

Routine Alignment Procedure:

1. Install and track the blade ([See Section 4.2](#)).
2. Check and adjust the vertical alignment of the blade guide arm ([See Section 4.5](#)).
3. Check and adjust the horizontal alignment of the blade guide arm ([See Section 4.6](#)).
4. Check and adjust the vertical angle of the blade guides ([See Section 4.9](#)).
5. Check and adjust the horizontal angle of the blade guides ([See Section 4.11](#)).
6. Check and adjust the spacing between the blade guide flanges and the back of the blade ([See Section 4.10](#)).
7. Check that the blade height scale accurately displays the actual distance from the bottom of the blade to the feed track and adjust if necessary ([See Section 4.13](#)).

Complete Alignment Procedure:

Perform all steps in this section to completely realign the resaw.

4.2 Blade Installation And Tracking

See **Figure 4-1**. Install a blade and apply the proper tension as shown below. [See Section 2.4](#)

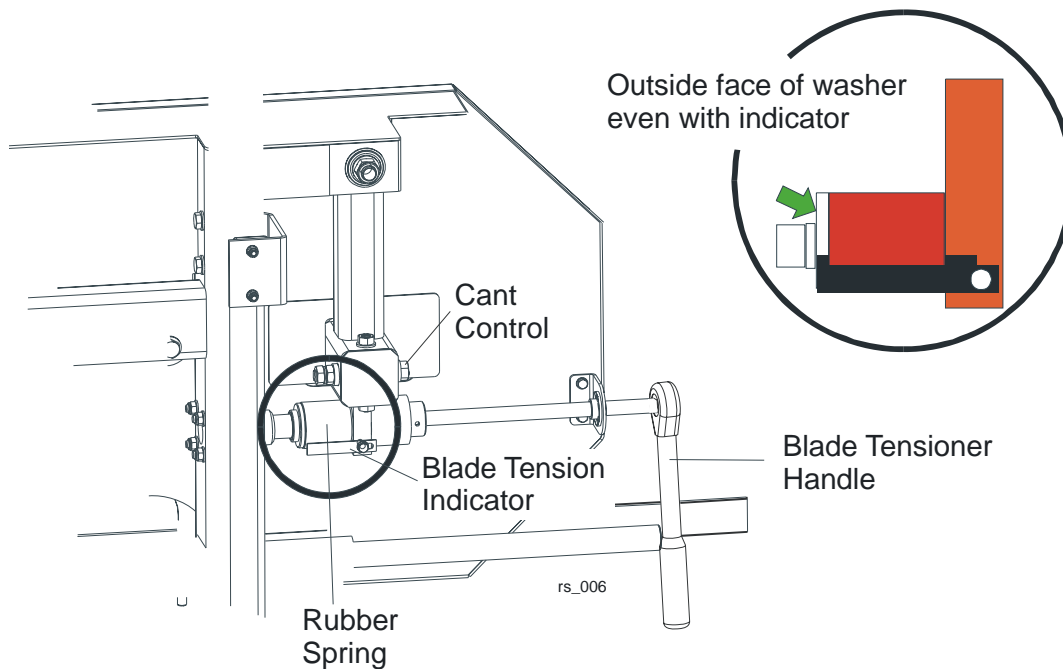

FIG. 4-1

1. Turn the key switch to the "H" position.



2. Open the blade housing cover.
3. Manually spin one of the blade wheels until the blade positions itself on the wheels.

See Figure 4-2. The blade wheels should be adjusted so that the gullet of 1 1/4" blades rides 3.0 mm (0.12") out from the front edge of the wheels (± 1.0 mm [0.04"]). The gullet of 1 1/2" blades should ride 4.5 mm (0.18") from the front edge of the wheels (± 1.0 mm

[0.04"]). Do not let the teeth ride on the belt.

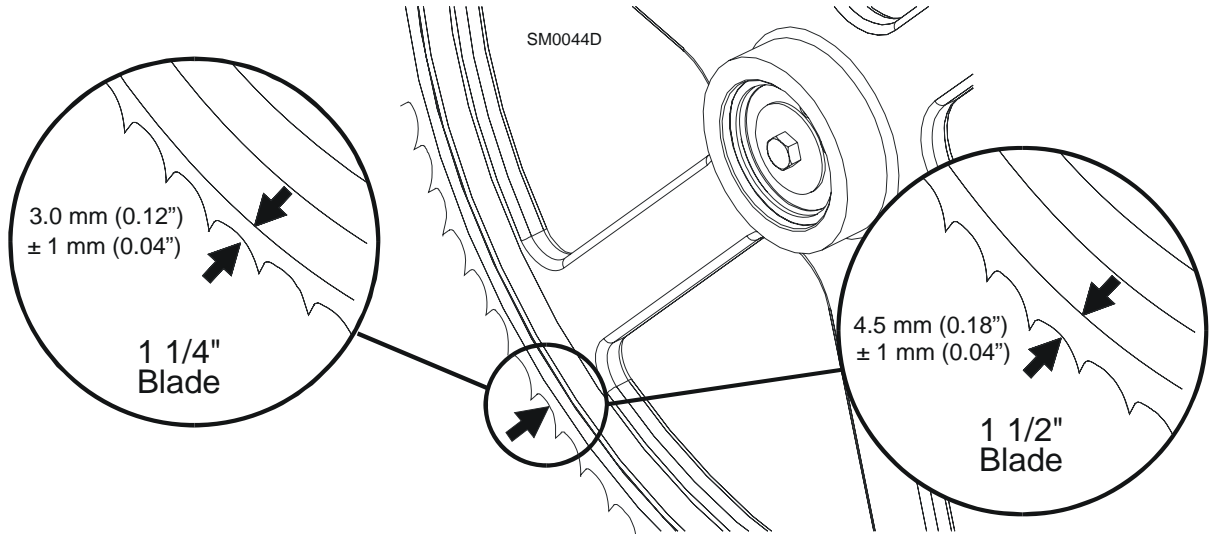

FIG. 4-2

To adjust where the blade travels on the idle-side blade wheel, use the cant control shown in **Figure 4-7**.

To move the blade out on the blade wheel, turn the cant adjustment bolt clockwise. To move the blade in on the blade wheel, turn the bolt counterclockwise.

Some adjustment in blade tension may be needed to compensate for adjustments made with the cant control.

Adjustment with the cant control is usually all that is required to track the blade properly on both blade wheels. The drive-side blade wheel will usually not have to be adjusted. If necessary, the drive-side wheel can be adjusted as follows:

Locate the nuts and the clamping screws located on the drive-side of the cutting head. If the blade is too far forward on the wheel, turn the screw located on the inside of the head counterclockwise and turn the screw located on the outside of the head clockwise. Make sure to tighten the nuts against the shaft housing when adjustment is complete.

4.3 Blade Wheel Alignment

The blade wheels should be adjusted so they are level in the vertical and horizontal planes. If the blade wheels are tilted up or down, the blade will want to travel in the tilted direction. If the blade wheels are tilted horizontally, the blade will not track properly on the wheels.

1. Use the blade guide alignment tool to check the vertical alignment of each blade wheel. Attach the tool to the blade near the inner blade guide mount. Be sure the tool does not rest on a tooth or burr, and is lying flat against the blade.

See Figure 4-3.

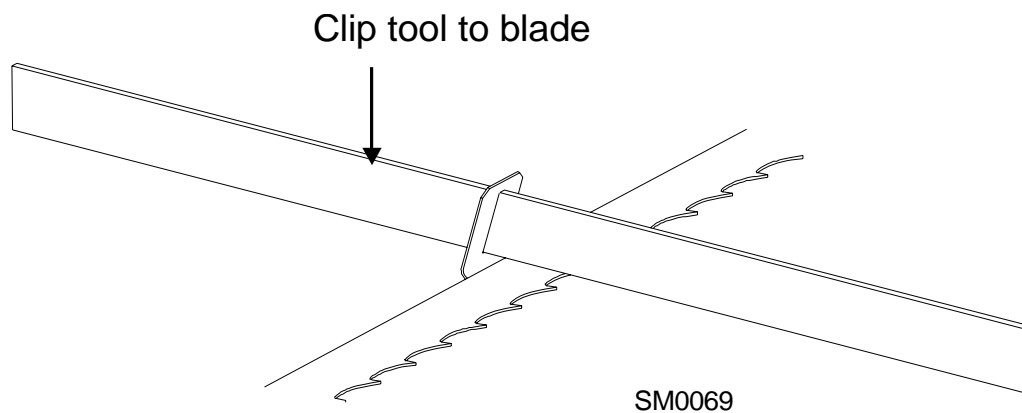

FIG. 4-3

2. Measure from the bottom of the tool to the top of the feed track.
3. If the two measurements differ by more than (± 1.0 mm), adjust the vertical tilt of the drive-side blade wheel.

See **Figure 4-4**. Use the vertical adjustment screws (marked with the blue and yellow arrows in the figure below) to adjust the drive-side blade wheel. Before adjusting the wheel, loosen the drive belt using the adjustment bolts marked with the orange arrows in the figure. Loosen the jam nut and the hex socket head screw marked with the red arrow in the figure and adjust the wheel with the vertical adjustment screws. To tilt the wheel down, loosen the top adjustment screw one quarter turn. Loosen the jam nut on the bottom adjustment screw and tighten the screw. Tighten the top and bottom jam nuts. To tilt the wheel up, loosen the bottom adjustment screw one quarter turn. Loosen the jam nut on the top adjustment screw and tighten the screw. Tighten the top and bottom jam nuts. Tension the drive belt properly ([See Section 3.8](#)).

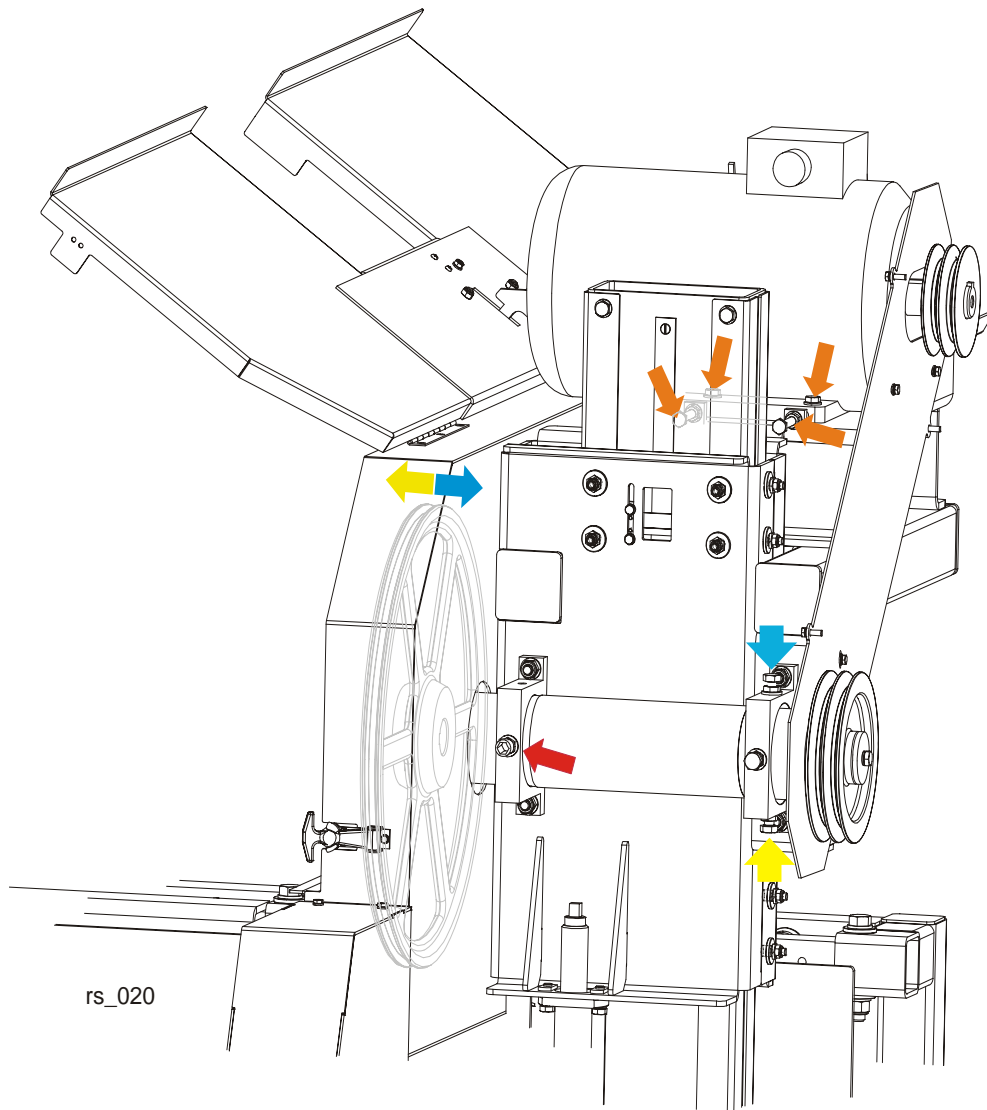

FIG. 4-4

4

Alignment

Blade Wheel Alignment

4. Recheck the vertical tilt of the drive-side blade wheel with the blade guide alignment tool. Readjust the blade wheel as necessary until the front and rear of the tool are the same distance from the feed track (± 1.0 mm).
5. Remove the tool from the blade and reattach it near the outer blade guide assembly.
6. Measure from the tool to the feed track at both ends of the tool. If the measurements at the front and rear ends of the tool differ more than (± 1.0 mm), adjust the vertical tilt of the idle-side blade wheel.

See Figure 4-5. Use the vertical adjustment screws to adjust the idle-side blade wheel. To tilt the wheel up, loosen the bottom adjustment screw one quarter turn. Loosen the jam nut on the top adjustment screw and tighten the screw. Tighten the top and bottom jam nuts.

To tilt the wheel down, loosen the top adjustment screw one quarter turn. Loosen the jam nut on the bottom adjustment screw and tighten the screw. Tighten the top and bottom jam nuts.

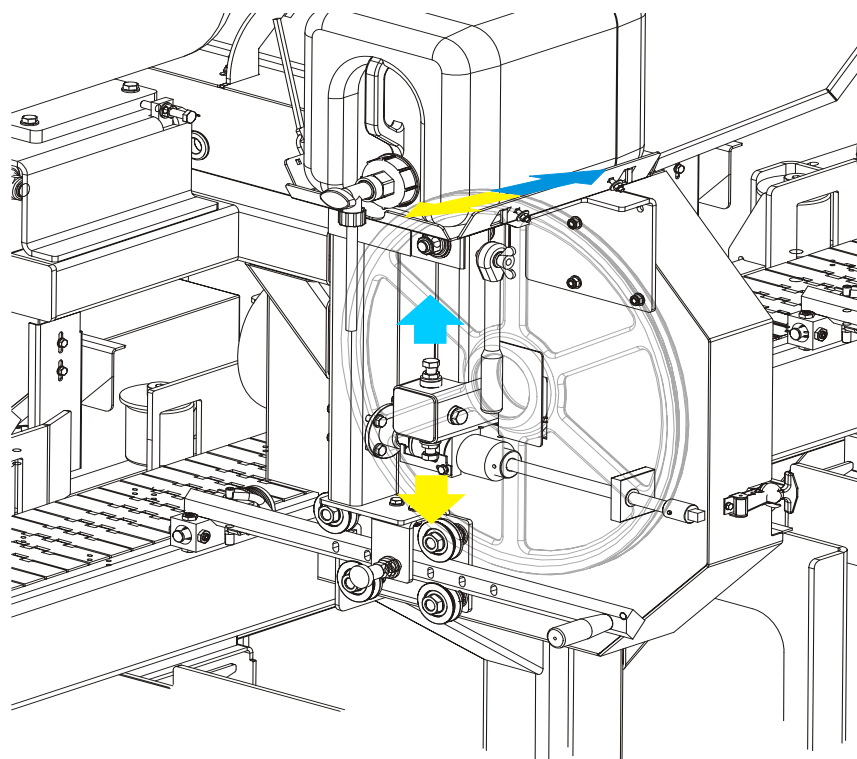

FIG. 4-5

7. Recheck the vertical tilt of the idle-side blade wheel with the blade guide alignment tool. Readjust the blade wheel as necessary until the front and rear of the tool are the same distance from the feed track.

8. Check the position of the blade on the idle-side blade wheel.

See **Figure 4-6**. The horizontal tilt of the blade wheel should be adjusted so that the gullet of an 1-1/4" blade is 3.0 mm out from the front edge of the wheel (± 1.0 mm).

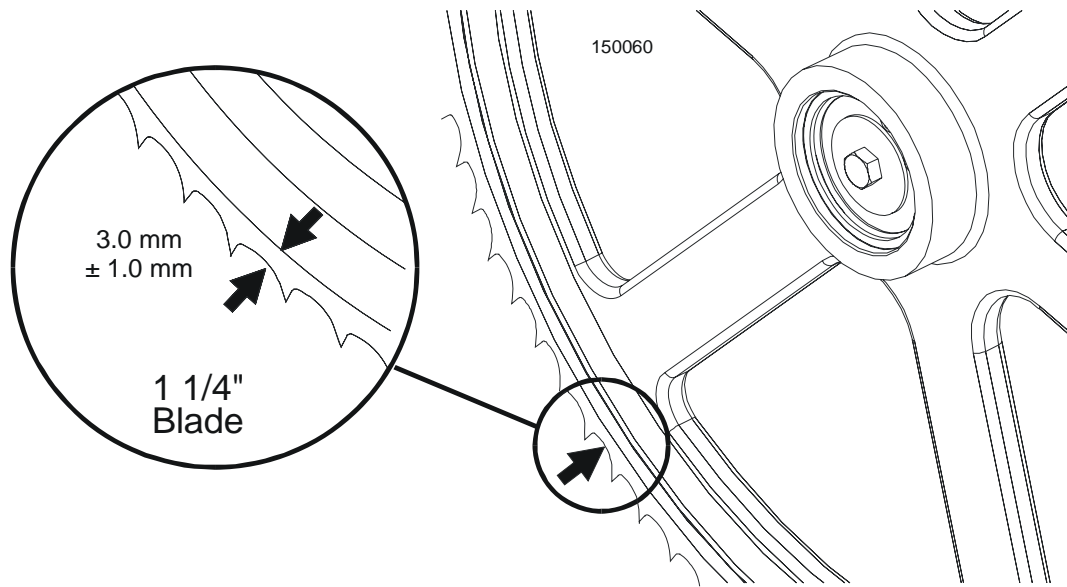

FIG. 4-6

See **Figure 4-7**. Use the cant control adjustment to adjust the idle-side blade wheel. If the blade is too far forward on the wheel, turn the cant control counterclockwise. If it is too far back on the wheel, turn the cant control clockwise.

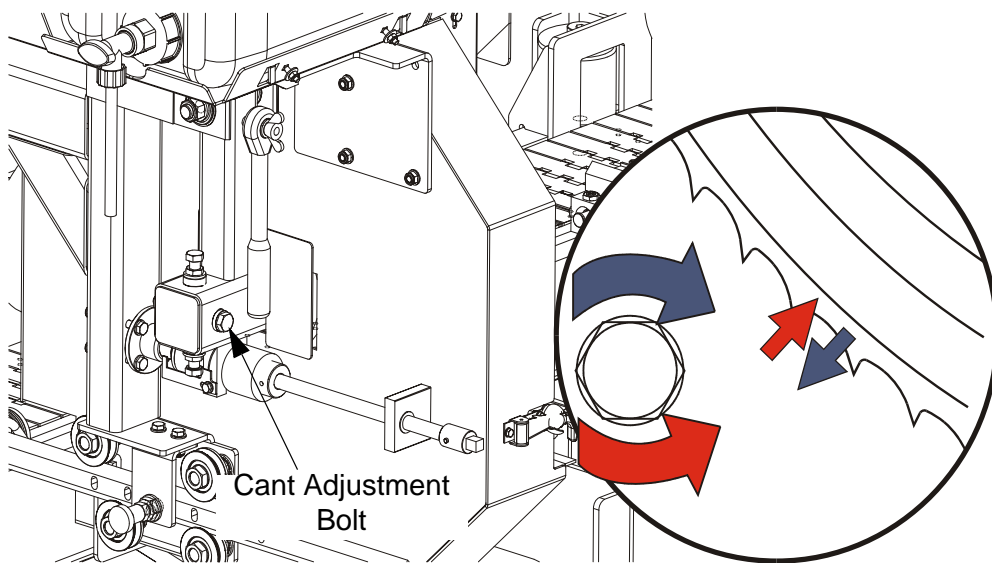

FIG. 4-7

4

Alignment

Blade Wheel Alignment

9. Check the position of the blade on the drive-side blade wheel. The blade should be positioned on the wheel as described for the idle-side blade wheel. Adjust the drive-side blade wheel if necessary.

See Figure 4-8. Use the horizontal adjustment screws (marked with the blue and yellow arrows on the figure below) to adjust the drive-side blade wheel. Before adjusting the wheel, loosen the drive belt using the adjustment bolts marked with the orange arrows in the figure.

To move the blade back on the wheel, loosen the right adjustment screw one quarter turn. Loosen the jam nut on the left adjustment screw and tighten the screw. Tighten the left and right jam nuts.

To move the blade out on the wheel, loosen the left adjustment screw one quarter turn. Loosen the jam nut on the right adjustment screw and tighten the screw. Tighten the left and right jam nuts. When the adjustment is complete, tension the drive belt properly ([See Section 3.8](#)).

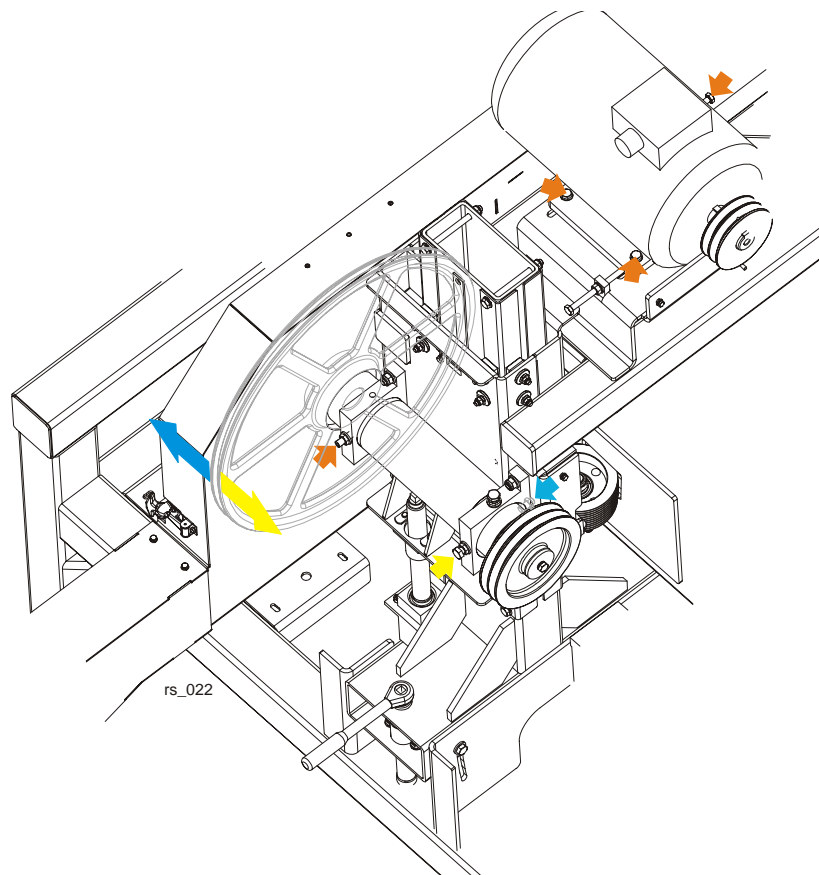

FIG. 4-8

4.4 Saw Head Adjustment

See **Figure 4-9**. The saw head should be set perpendicular to the vertical mast. Using the two sets of adjustment screws in the mast slide pads, you can adjust the saw head in relation to the mast. To raise or lower the outside of the saw head, loosen the locking nuts on either of the sets of screws. Then turn the adjustment nuts clockwise to raise the outside of the saw head or counterclockwise to lower the outside of the saw head. **NOTE:** Be sure to adjust the nuts evenly so the slide pad is parallel to the mast tube. If further adjustment is needed and one set of the nuts has been fully adjusted, use the other.

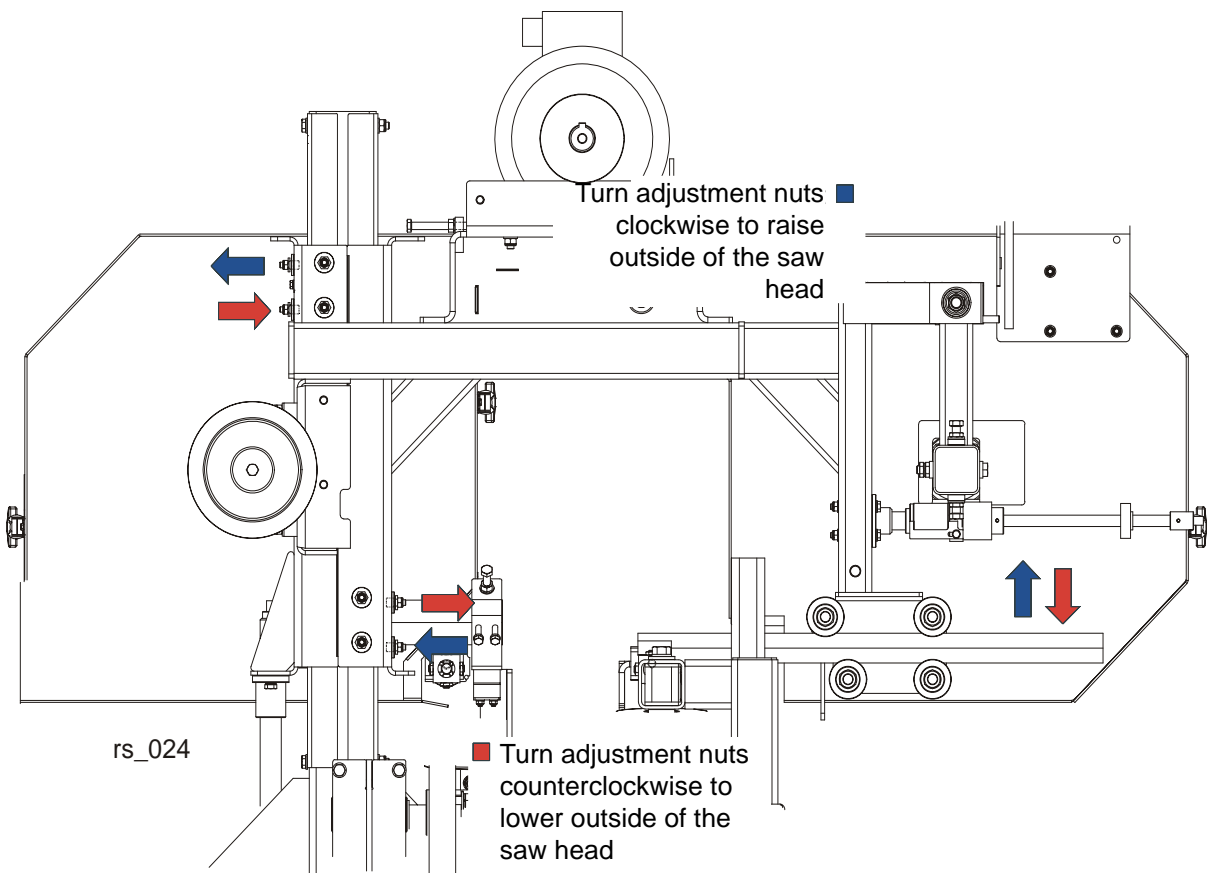

FIG. 4-9

4.5 Blade Guide Arm Vertical Adjustment

1. Adjust the blade guide arm out to within 1/2" (15 mm) of full open.
2. Measure the distance from the top surface of the feed track to the arm.

See Figure 4-10.

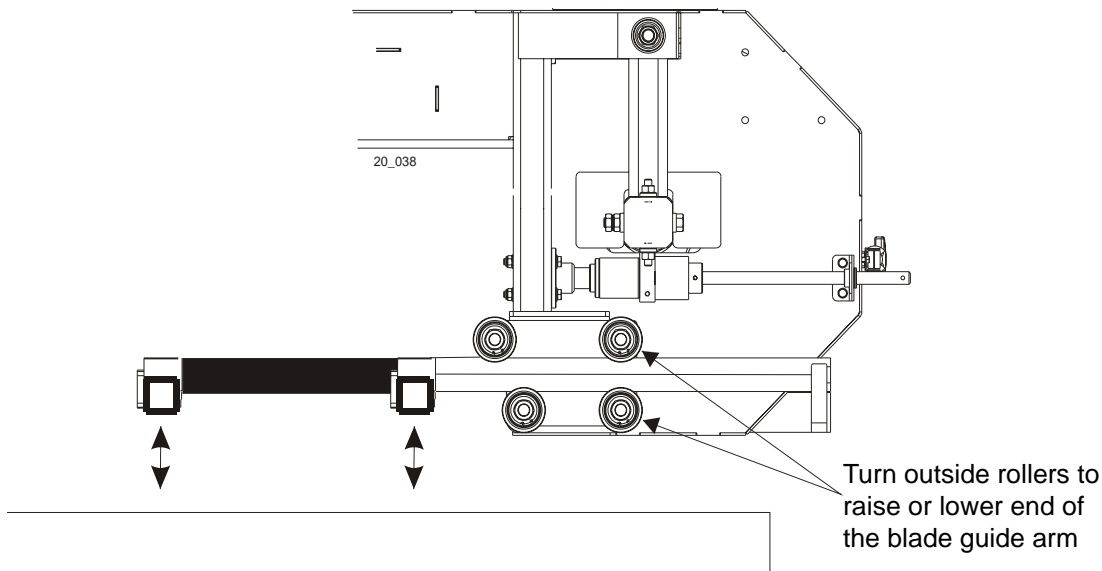

FIG. 4-10

3. Adjust the blade guide arm in to within 1/2" (15 mm) of full closed. Measure again the distance between the arm and the feed track.
4. Adjust the arm so that the measurement from the top of the track feed to the arm in the closed position is the same as the measurement from the top of the track feed to the arm in the open position.

If the arm is too low in the closed position, loosen the lower outside roller and tighten the upper outside roller. (See Step 5.)

If the arm is too high in the closed position, loosen the upper outside roller and tighten the lower outside roller. (See Step 5.)

5. The rollers are mounted on cam bolts that raise or lower the arm when turned.

To adjust the rollers, locate the cam bolt inside the housing and turn until the arm is lowered or raised as needed. Recheck the arm in both, open and closed positions. Repeat adjustments until the arm is the same distance from the track feed in the open

and closed position.

6. The blade guide arm should be snug, but not too tight, in the rollers. You should be able to move it in and out with firm hand pressure. There should be no side-to-side play.

4.6 Blade Guide Arm Horizontal Adjustment

1. Put the blade guide assembly back in the arm (if you took it out). Put the assembly back so that the flanged collar on the roller is about 3.0 mm (0.04") from the back of the blade when the arm is 15 mm (0.6") from full open.
2. Close the throat to within 15 mm (0.6") from fully closed. Check to see that the flange is the same distance from the back of the blade.

See Figure 4-11.

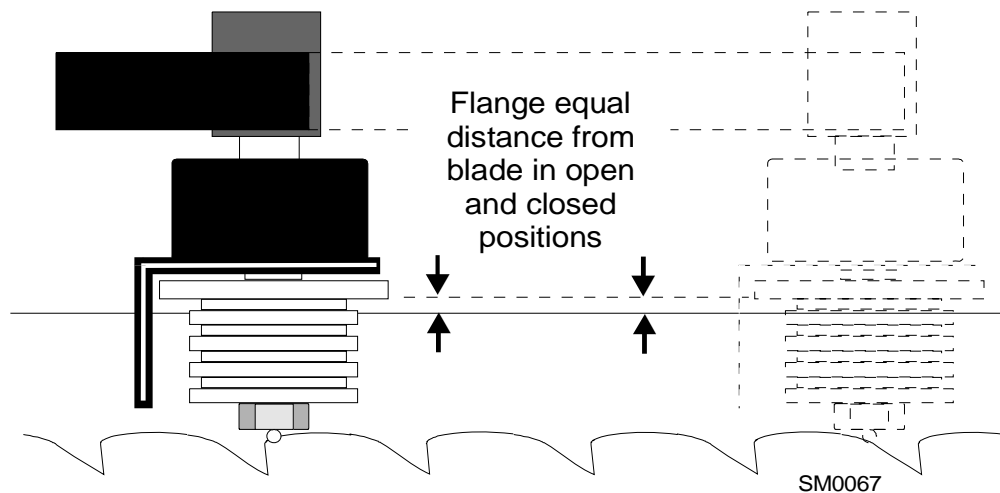

FIG. 4-11

3. If adjustment is needed, the guide rollers can be adjusted in or out on the threaded mounts to open or close the gap.

4

Alignment

Blade Guide Arm Horizontal Adjustment

See Figure 4-12.

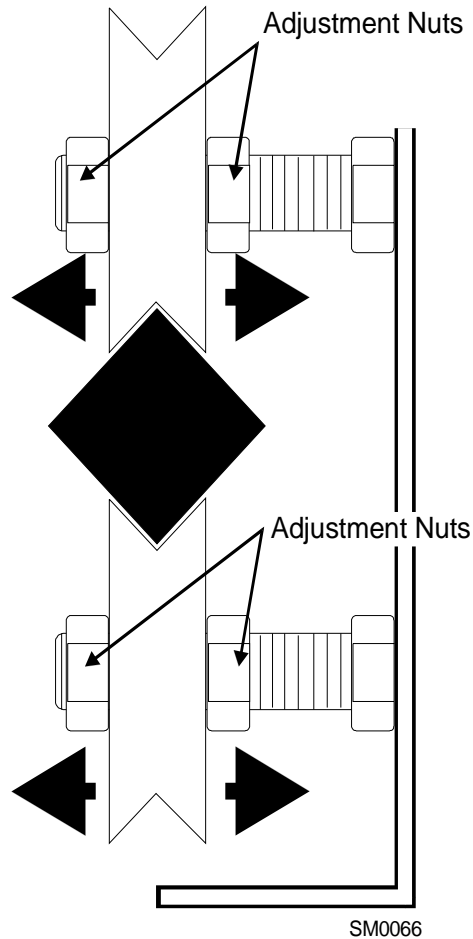

FIG. 4-12

4. Adjusting the outside two rollers inward will cause the flange to move away from the blade.
5. Adjusting the two outside rollers outward will cause the flange to move toward the blade.
6. Adjust until the roller flange is the same distance from the back of the blade in the open and closed position.

4.7 Aligning the Blade Guides

Each Wood-Mizer resaw has two blade guide assemblies that help the blade maintain a straight cut. The two blade guide assemblies are positioned on the cutting head to guide the blade on each side of the material being cut.

One blade guide assembly is mounted in a stationary position on the drive side of the cutting head. This assembly is referred to as the "inner" blade guide assembly.

The other blade guide assembly is mounted on the idle side of the cutting head. It is referred to as the "outer" assembly and is adjustable for various widths of materials to be processed.

Blade guide alignment includes four steps:

- Blade Deflection,
- Blade Guide Vertical Tilt,
- Blade Guide Flange Spacing,
- Blade Guide Horizontal Tilt.

Perform the blade guide alignment after you have aligned the blade on the wheels. After blade guide alignment, check the scale indicator to make sure it is adjusted properly ([See Section 4.13](#)).

NOTE: During blade guide alignment, remove the blade guide adjusting screws and apply a lubricating oil such as 10W30 or Dexron III to each screw. This will prevent the screws and threaded holes from corroding and make screw adjustments easier.

4.8 Blade Deflection

Perform the following steps to achieve proper blade deflection with the blade guides.

1. Raise the carriage until the blade is 200 mm above the feed track. Measure the actual distance with a tape from the top of the track to the bottom of the blade.
2. Install the blade guides. Make sure the two set screws shown are threaded into the blade guide shaft until they touch each other.

See Figure 4-13.

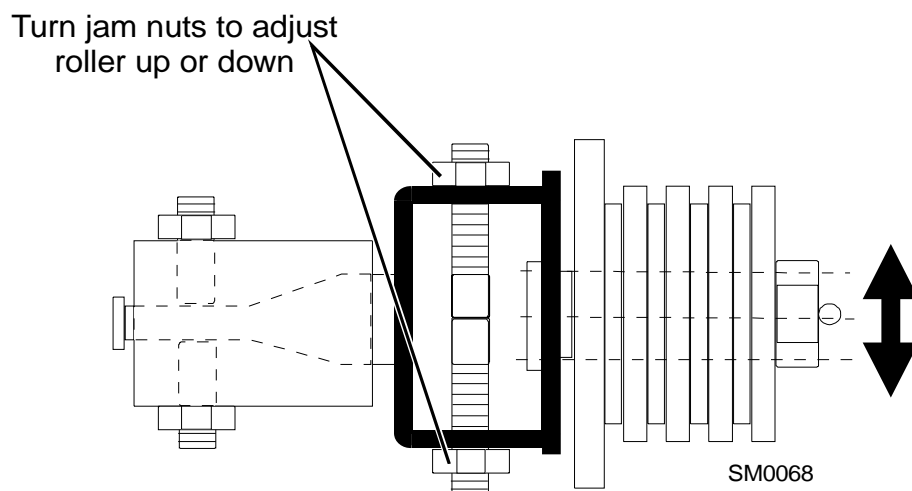

FIG. 4-13

3. Loosen the bottom jam nut and tighten the top jam nut until the blade guide deflects the blade down 6.0 mm (0.24").
4. Repeat for the other blade guide.

NOTE: Be sure that the blade guide touches the blade in both guide assemblies. The outer blade guide should be checked with the arm all the way in and all the way out.

4.9 Blade Guide Vertical Tilt Adjustment

Check that the blade guide does not tilt the blade up or down. A Blade Guide Alignment Tool (BGAT) is provided to help you measure the vertical tilt of the blade.

1. Open the blade guide arm 15 mm (0.6") from full open.
2. Clamp the alignment tool on the blade. Position the tool close to a blade guide roller. Be sure the tool does not rest on a tooth or burr, and is lying flat on the blade.

See Figure 4-14.

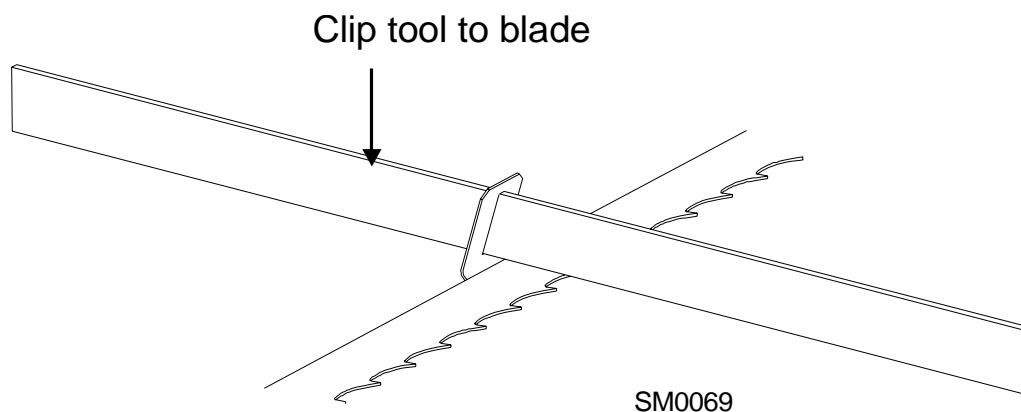

FIG. 4-14

3. Measure the distance from the bottom of the tool to the feed track chain at the center of the tool and then at the front end of the tool.
4. The two distances should be equal. If they differ, adjust the vertical tilt of the blade guide using the adjustment screws shown in the figure below.

See Figure 4-15. Loosen the jam nuts on the top and bottom vertical tilt adjustment screws. To tilt the roller up, loosen the bottom screw and tighten the top screw. To tilt the roller down, loosen the top screw and tighten the bottom screw. Tighten the jam nuts and

4

Alignment

Blade Guide Vertical Tilt Adjustment

recheck the tilt of the blade.

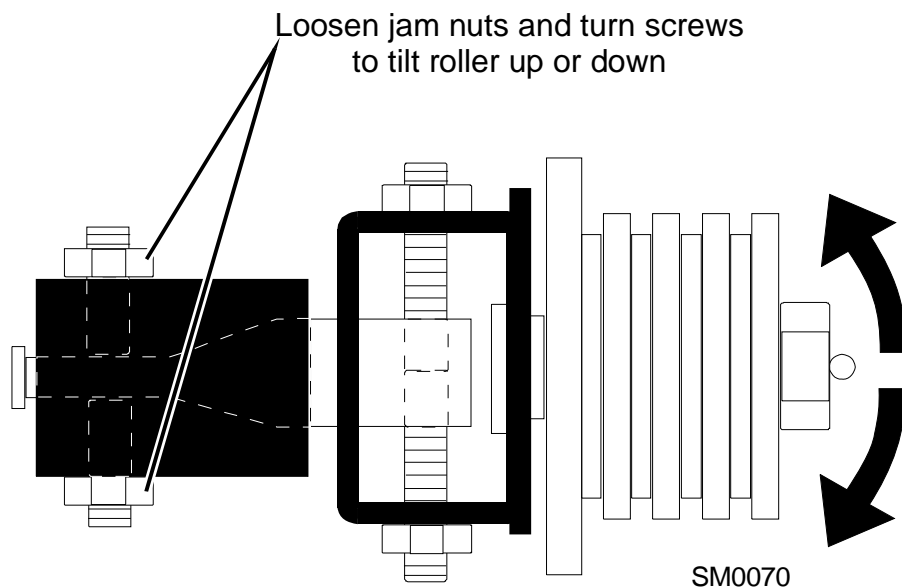

FIG. 4-15

5. Measure the distance from the bottom of the tool to the top of the feed track chain at the rear end of the tool. If the measurement does not equal the other two measurements taken, readjust the vertical tilt of the blade guide.
6. Move the blade guide alignment tool close to the other blade guide and repeat the above steps. Adjust the vertical tilt of this guide if necessary.

NOTE: If major adjustments to blade guide tilt were made, measure the distance between the blade and the feed track chain again to ensure the correct 6.0 mm (0.24") blade guide deflection. Adjust if necessary.

4.10 Blade Guide Spacing

HINT: When adjusting blade guide spacing, loosen the top set screw and one side set screw only. This will ensure horizontal and vertical tilt adjustments are maintained when the set screws are retightened.

1. Adjust the inner blade guide so the blade guide flange is approximately 1.5 – 3.0 mm (0.06 - 0.12") from the back of the blade.
2. Loosen one side and one top set screw shown. Tap the blade guide forward or backward until properly positioned.

See Figure 4-16.

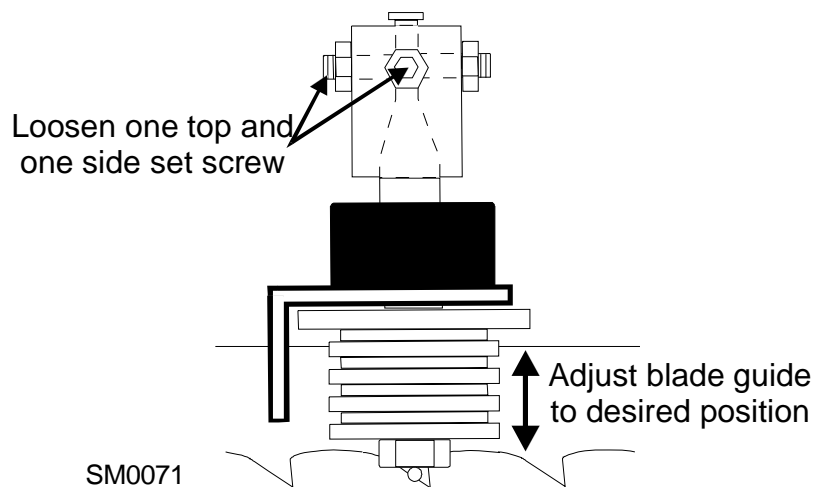

FIG. 4-16

3. Retighten the two set screws.
4. Adjust the outer blade guide in the same way so the blade guide flange is approximately 1.5 – 3.0 mm (0.06 - 0.12") from the back of the blade.

4.11 Blade Guide Horizontal Tilt Adjustment

1. Finally, both blade guides must be tilted horizontally. Adjust the blade guide arm halfway in.

See Figure 4-17.

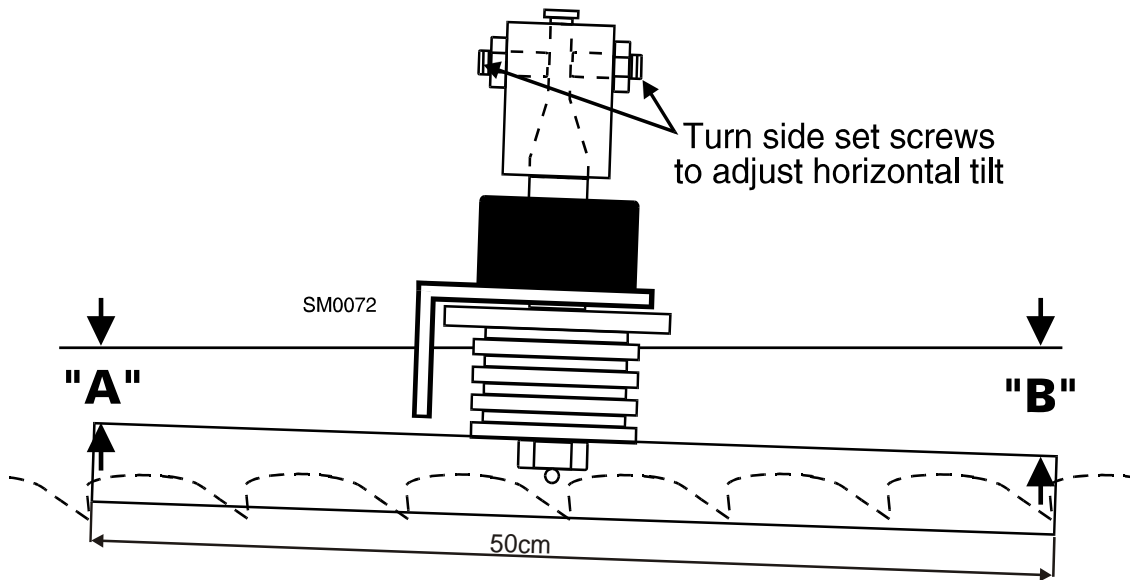

FIG. 4-17

2. Place the Blade Guide Alignment Tool against the face of the outer blade guide roller.
3. Center the tool on the roller and measure between the back edge of the blade and the ruler at the end closest to the inner blade guide ("B").
4. Measure between the back edge of the blade and the other end of the ruler ("A").
5. The roller should be tilted slightly to the left ($A = B - 6.0 \text{ mm [0.24"]}$).
6. Use the side set screws to adjust the horizontal tilt of the roller.
7. Repeat steps 3-7 for the inner blade guide roller.

NOTE: Once the blade guides have been adjusted, any cutting variances are most likely caused by the blade. See the **Wood-Mizer® Blade Handbook, Form #600**.

4.12 Clamp Roller Alignment

Clamp Roller Arm Tilt

Check that for the first and the third clamping rollers the end closest to the infeed table is 5 mm ($\pm 1\text{mm}$) from the top surface of the feed track chain (see the figure below). If the distance is different, adjust the tilt of the roller arm using the adjustment screws in the clamp roller guide.

See Figure 4-18. Release the clamp. Loosen locking nuts on the adjustment screws located in the clamp roller guide. Use appropriate adjustment screws to adjust the clamp roller arm.

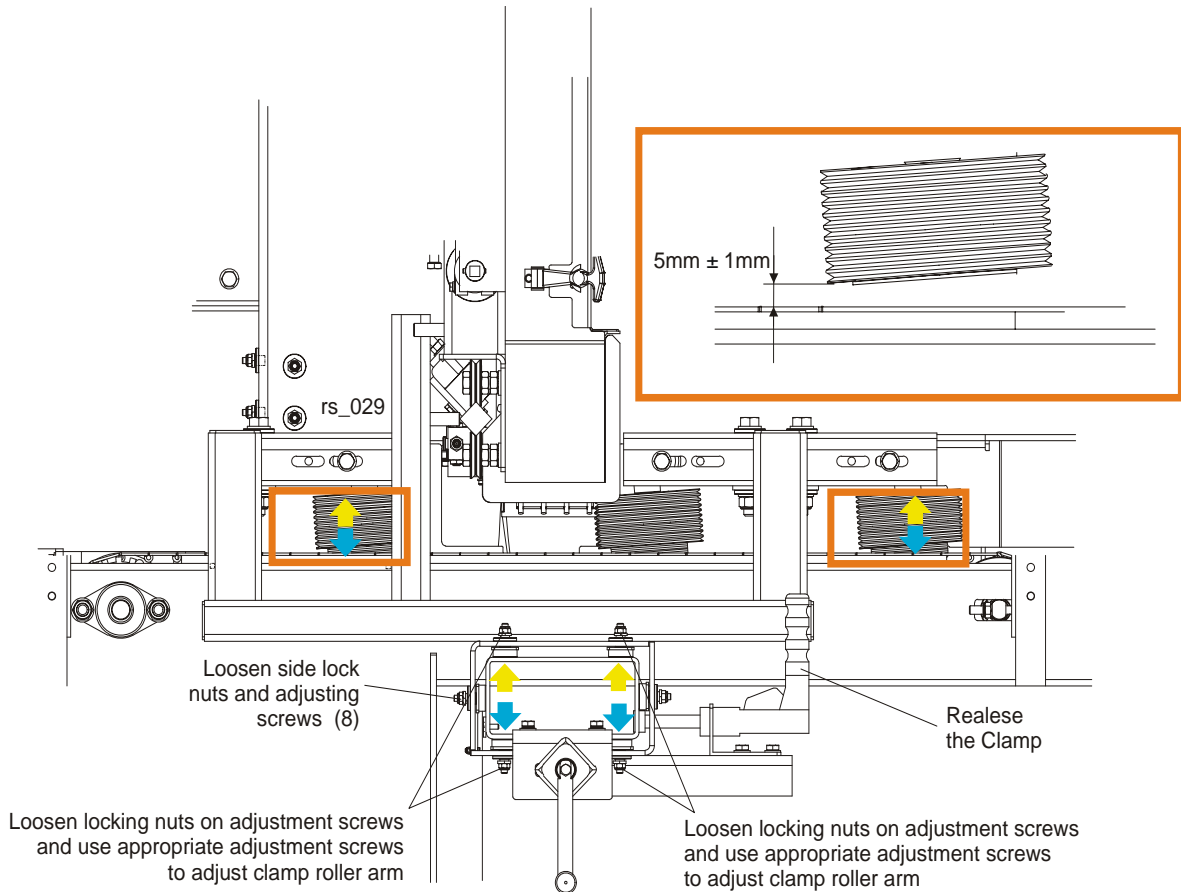

FIG. 4-18

4 Alignment

Clamp Roller Horizontal Adjustment

Clamp Roller Horizontal Adjustment

Make sure the clamping rollers are aligned.

See **Figure 4-19**. Use the adjustment bolts, shown below, to move each roller in or out

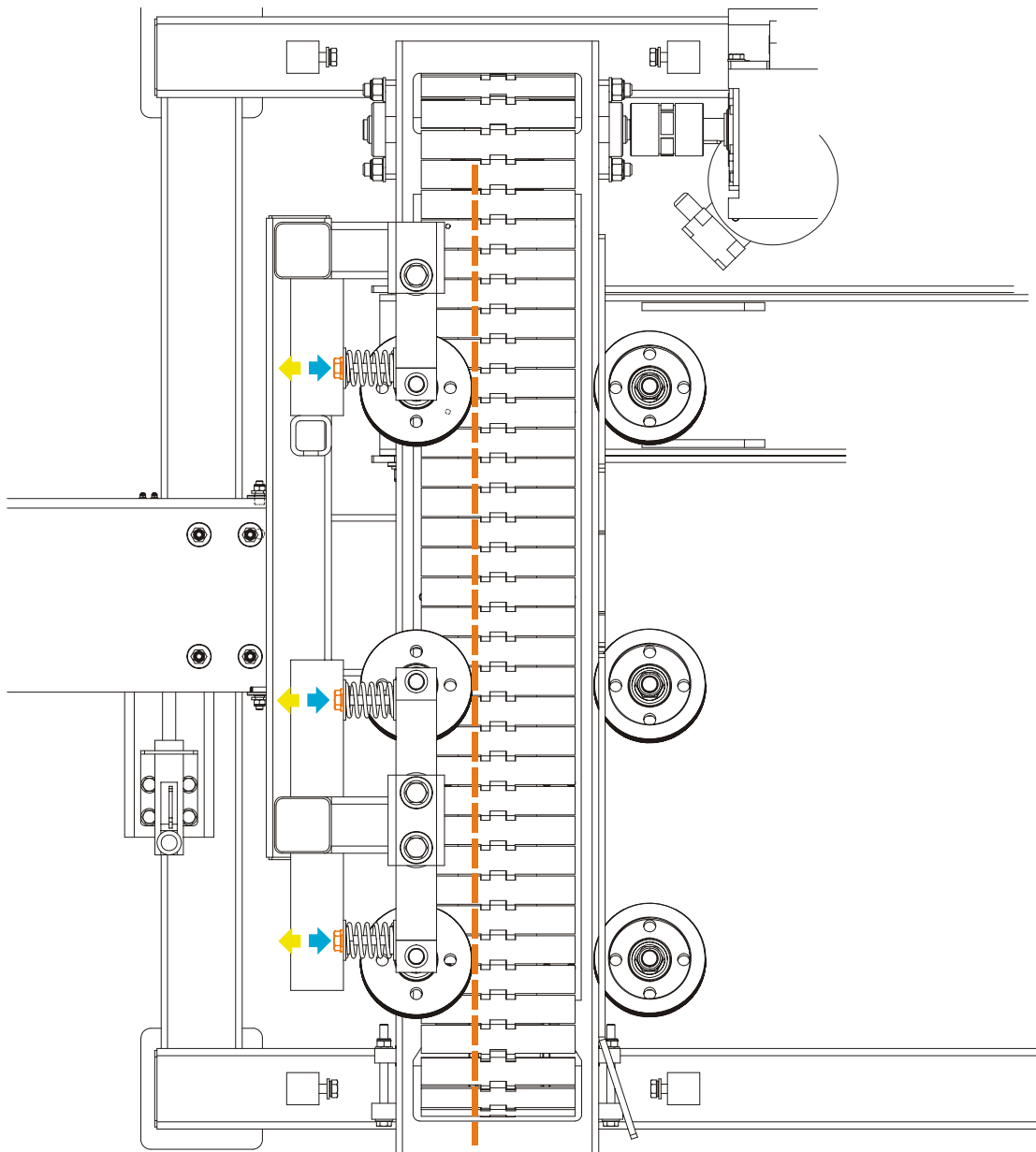

FIG. 4-19

until the rollers are in line.

4.13 Blade Height Scale Adjustment

After the entire resaw has been aligned and all adjustments made, check that the blade height scale indicates the true distance from the blade to the feed track chain.

1. Measure from the bottom edge on a down-set tooth of the blade to the top of the feed track chain.

See Figure 4-20.

2. View the blade height scale with eyes level with the indicator.

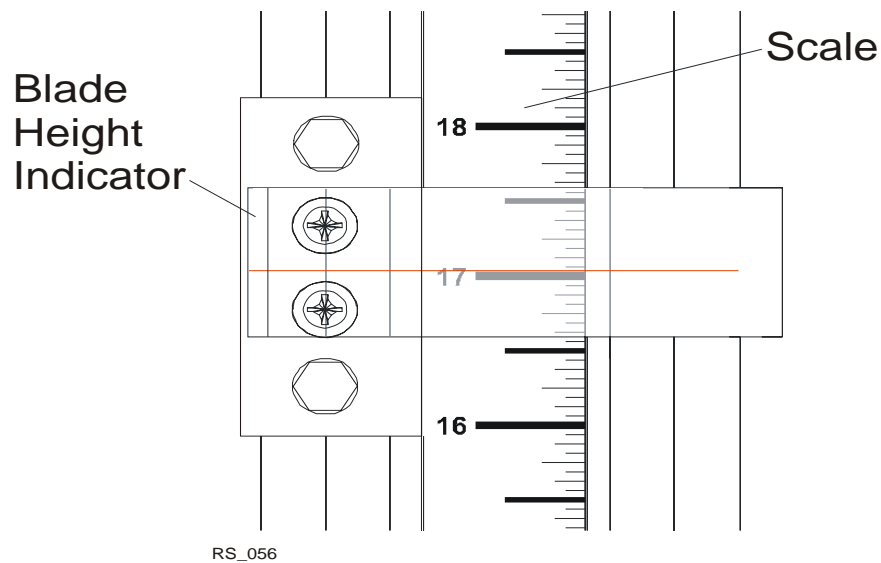

FIG. 4-20

3. Loosen the indicator bracket mounting bolts and adjust the bracket until the indicator is aligned with the correct mark on the scale. Retighten the bracket mounting bolts.

For example, if the measurement from blade to feed track chain was 100 mm, make sure the indicator reads 100 mm on the scale.

SECTION 5 SPECIFICATIONS

5.1 Overall Dimensions

See **Figure 5-1**. The major dimensions of the resaw are shown below (all dimensions are in millimeters).

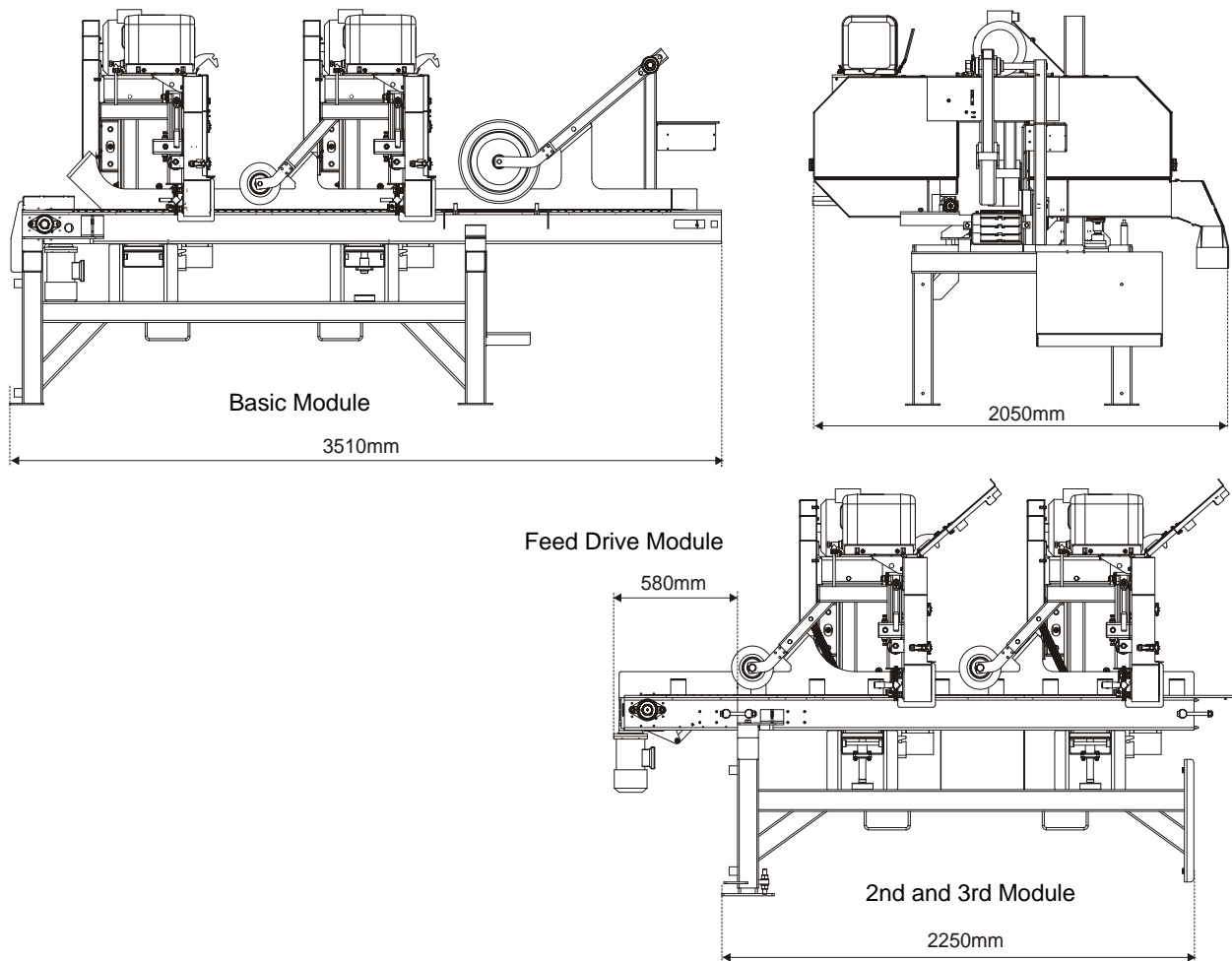

FIG. 5-1

See Table 5-1. The overall dimensions of the resaw are listed in the table below.

Weight	kg
Height	1900 mm
Width	2050 mm
Length	First Module: 3510 mm Second and Third Module: 2250mm

TABLE 5-1

5 Specifications
Overall Dimensions

See Figure 5-2. The figure shows locations of the resaw legs.

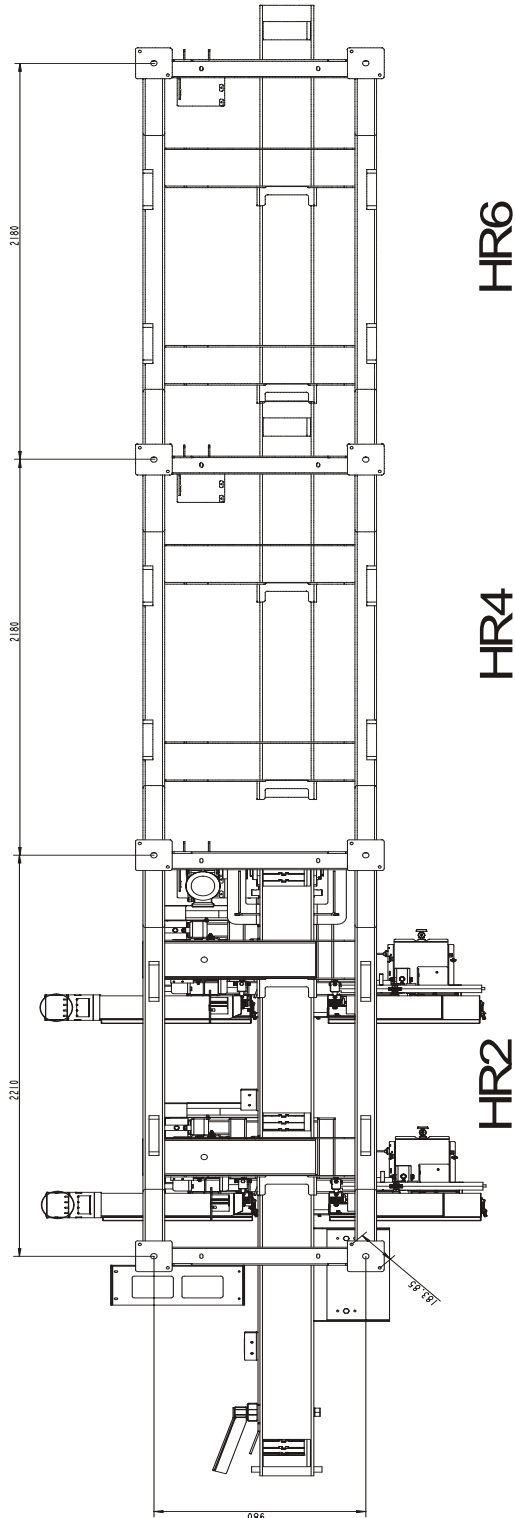

FIG. 5-2

5.2 Cutting Capacity

See Table 5-2. The material size and performance capacities of the resaw are given below.

Cutting Length	0.9 - 3.6 m
Material Height	10-400 mm
Material Width	75-300 mm
Feed Speed	0-25 m/min
Minimum Cutting Height	4 mm
Maximum Cutting Height	200 mm

TABLE 5-2

See Table 5-3. Wood-Mizer TRU•SHARP™ offers three types of blades to provide efficient sawing. The type of wood you saw should determine which blade you choose for optimum performance.

Motor Size	Recommended Blade Type		
	Softwood	Medium Hardwood	Frozen Timber or Dense Hardwood
5 HP - 15 HP	.042 x 7/8 x 1 1/4"	.042 x 7/8 x 1 1/4 "	.045 x 7/8 x 1 1/4" F1

5.3 Blade Motor Specifications

See Table 5-4. See the table below for blade motor specifications for your resaw model.

Motor Type	Manufacturer	Model	Power	Other Specifications
E11 Electric	Tamel SA, Poland	Sg 132M-4B HM	7,5kW	400 V/50Hz; 15 Amp; 1450 r.p.m.
E15 Electric	Tamel SA, Poland	Pssg 132M-4A	11kW	400 V/50Hz; 23 Amp; 1450 r.p.m.

TABLE 5-4

See Table 5-5. The noise levels of the resaw are listed below¹².

	Noise level
HR2E11/15S	L _{EX8} = 94,0 dB (A) (cant loading) L _{EX8} = 94,0 dB (A) (cant receiving)
HR3E11/15S	L _{EX8} = 96,7 dB (A) (cant loading) L _{EX8} = 86,2 dB (A) (cant receiving)
HR4E11/15S	L _{EX8} = 96,7 dB (A) (cant loading) L _{EX8} = 92,9 dB (A) (cant receiving)

TABLE 5-5

1. The noise level measurement was taken in accordance with PN-EN ISO 3746 Standard . The noise exposure level given above concerns an 8-hour work day.
2. The measured values refer to emission levels, not necessarily to noise levels in the workplace. Although there is a relation between emission levels and exposure levels, it is not possible to determine with certainty if preventives are needed or are not needed. The factors affecting a current level of noise exposure during work are inter alia room characteristics and characteristics of other noise sources, e.g. number of machines and machining operations nearby. Also, the permissible exposure level value may vary depending on country. This information enables the machine's user to better identify hazards and a risk.

5.4 Electrical Diagram, CE version, HR2

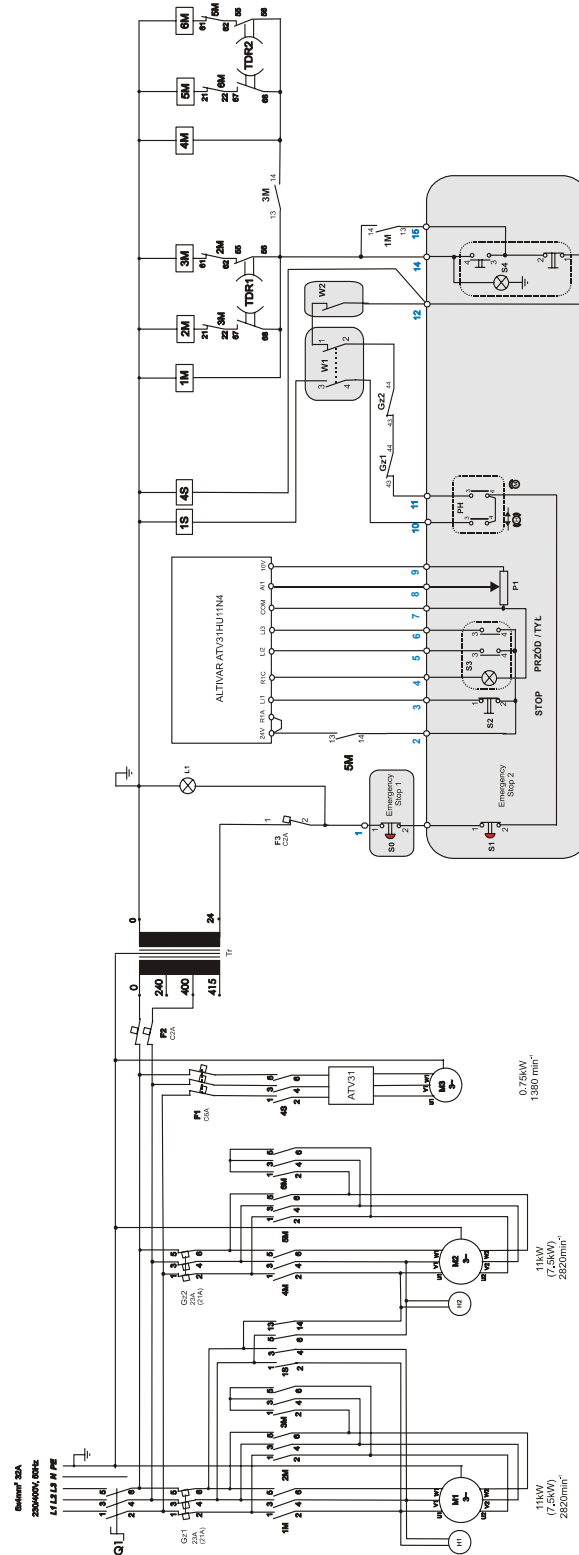

FIG. 5-3

5.5 Electrical Diagram, CE version, HR4

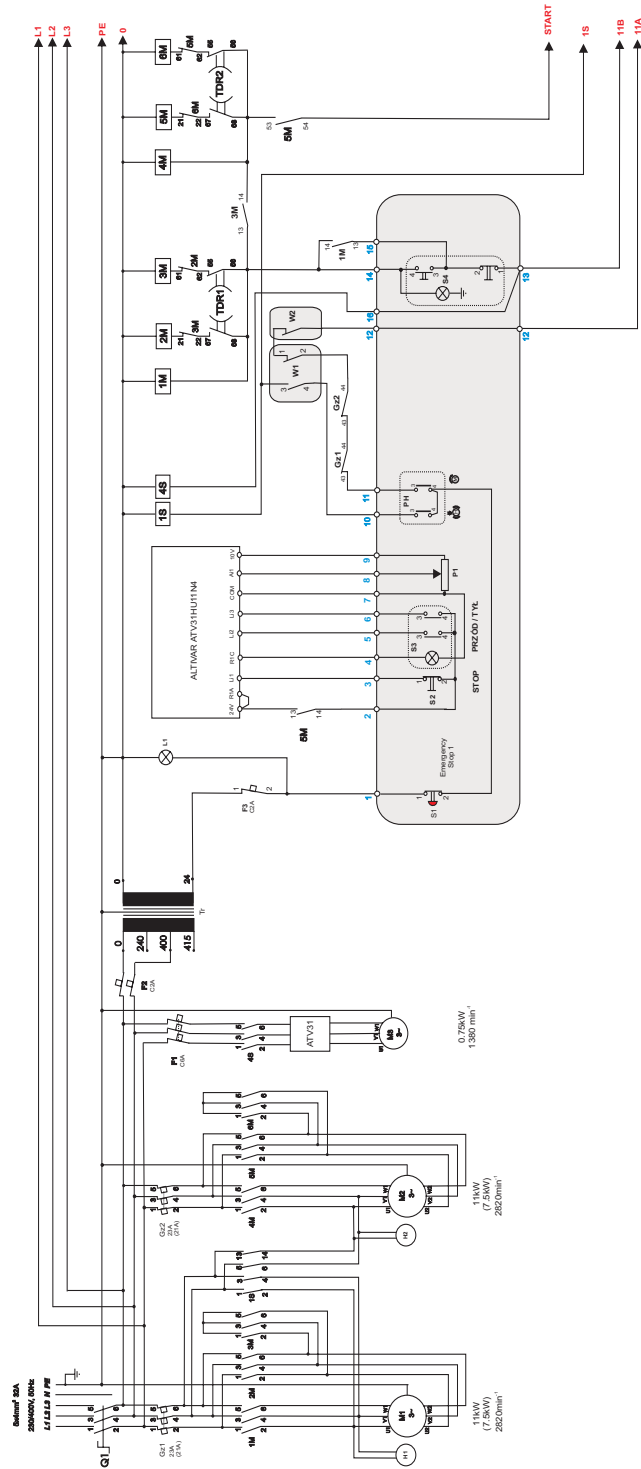

FIG. 5-4

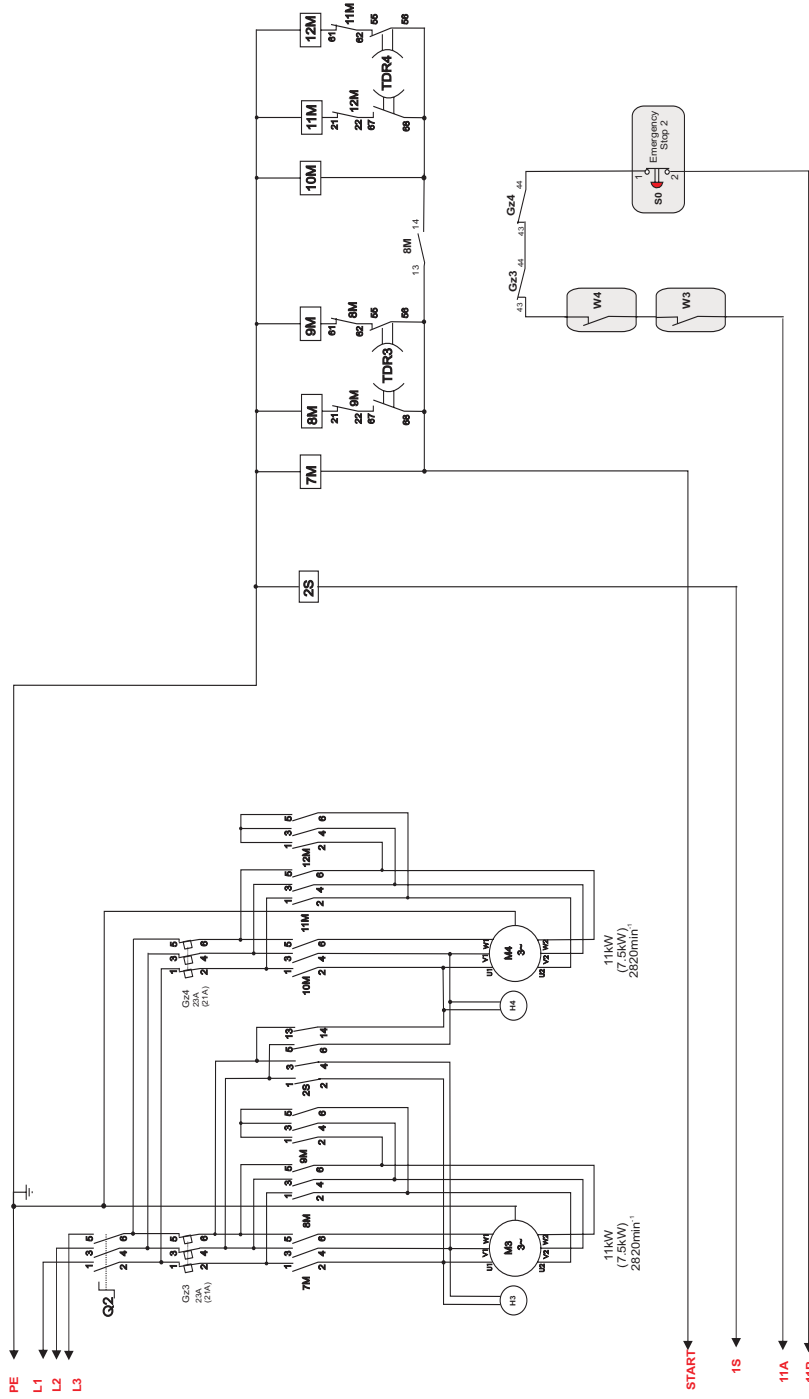

FIG. 5-5

5.6 Electrical Diagram, CE version, HR6

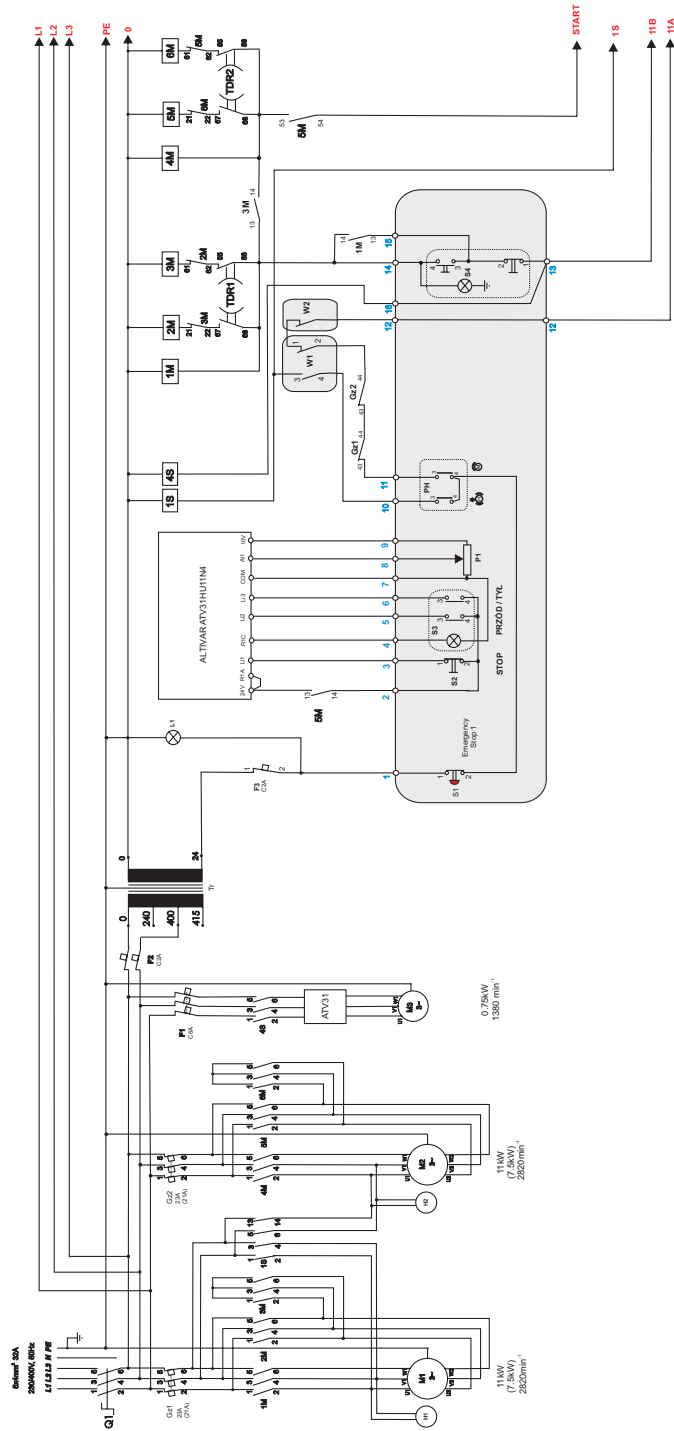

FIG. 5-6

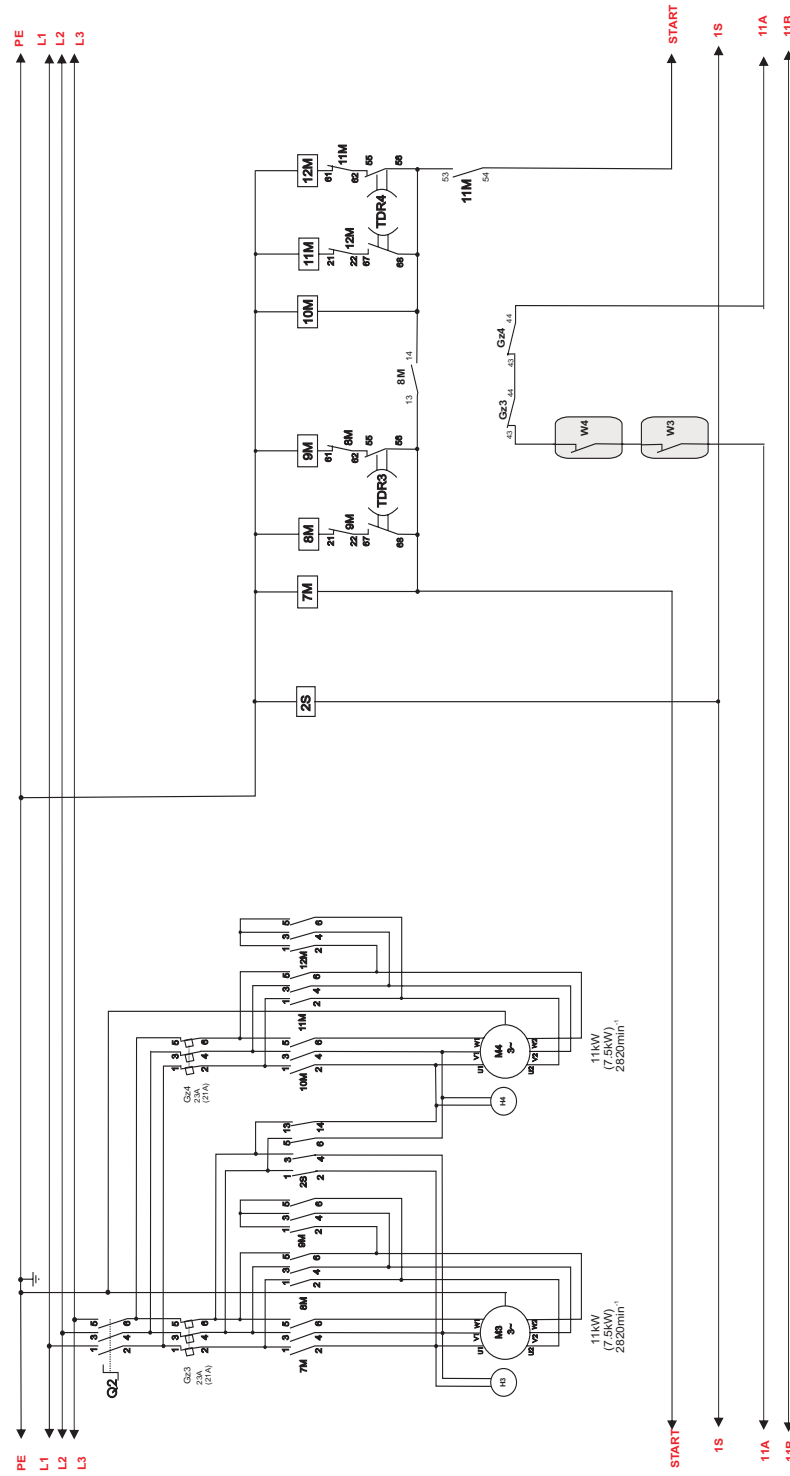

FIG. 5-7

5 Specifications
Electrical Diagram, CE version, HR6

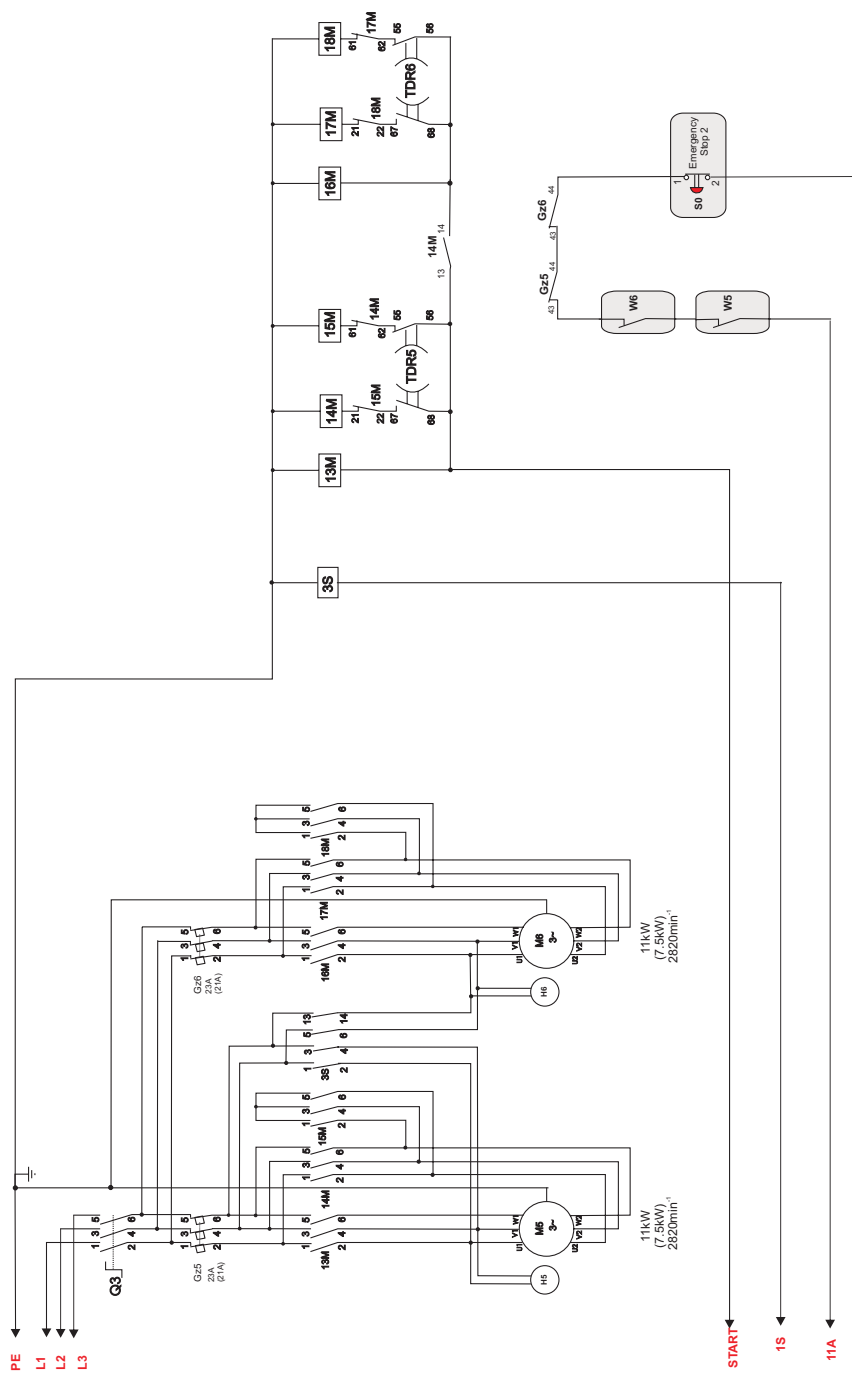

FIG. 5-8

5.7 Electrical Component List, HR

Symbol	Wood-Mizer Part No.	Description	Manufacturer
Q	095473	Switch ABB OT45 E3	ABB
Gz1, Gz2, Gz3, Gz4, Gz5, Gz6	084330	Motor Circuit Breaker Gz1 M21	SCHNEIDER ELECTRIC
1M, 2M, 4M, 5M, 7M, 8M, 10M, 11M, 13M, 14M, 16M, 17M	084306	Contactor LC1 D18 B7	SCHNEIDER ELECTRIC
3M, 6M, 9M, 12M, 15M, 18M		Contactor LC1 D12B7	SCHNEIDER ELECTRIC
1S, 2S, 3S, 4S	084305	Contactor LC1 K0610B7	SCHNEIDER ELECTRIC
F1	091554	Switch C60N 3P C6	SCHNEIDER ELECTRIC
F2		Switch C60N 2P C2	SCHNEIDER ELECTRIC
F3		Switch C60N 1P C2	SCHNEIDER ELECTRIC
TR		Transformator TSM160	BREVE
TDR1, TDR2, TDR3, TDR4, TDR5, TDR6	084037	Time Relay LAD S2	SCHNEIDER ELECTRIC
L1	090448	Control Lamp, White M22 LED24V	MOELLER
ATV	093488	Speed Controller ATV31HU11N4	SCHNEIDER ELECTRIC
M1, M2	089049	Blade Drive Motor SG132S -4PC HM	INDUKTA
H1, H2		Motor Brake H132	EMA-ELFA
W1, W2	094232	Emergency Switch AZ17-11ZRK	SCHMERSAL
S0	094726	Emergency Switch M22	SCHNEIDER ELECTRIC
S1	086556	Emergency Switch M22	SCHNEIDER ELECTRIC

5**Specifications***Electrical Component List, HR*

S2	091364	Button M22	MOELLER
S3	091359	Switch M22 3 position	MOELLER
P1	093749	Potentiometer M22-R1K (229489)	MOELLER
PH	091361	Key Switch M22-WRS3	MOELLER
M3	090104	Motor SKh80X-4C1 IMB14/1-162	BESEL

5.8 V-Belt Sizes

See Table 5-6. Belt sizes for the resaw are shown.

Belt Description	Belt Size	Wood-Mizer Part No.
Drive Belt (E15)	2BX70	P04857-2
Blade Wheel Belt	B72.5	017922

TABLE 5-6

5.9 Dust Extractor Specifications

See Table 5-7. Specifications of the dust extractors used on the resaw for each saw head are listed below.

Airflow	1500 m ³ /h
Inlet diameter	150 mm
Motor power	1,5 kW
Number of sacks	1 pcs
Sack capacity	0.25 mp
Weight	110 kg
Recommended conveying air velocity in the duct	20 m/s

TABLE 5-7



IMPORTANT! The dust extractor hoses must be grounded or made with materials not accumulating electrostatic charge.

SECTION 6 REPLACEMENT PARTS

6.1 How To Use The Parts List

- Go to the appropriate section and locate the part in the illustration.
- Use the number pointing to the part to locate the correct part number and description in the table.
- Parts shown indented under another part are included with that part.
- Parts marked with a diamond (◆) are only available in the assembly listed above the part.

See the sample table below. Sample Part #A01111 includes part F02222-2 and subassembly A03333. Subassembly A03333 includes part S04444-4 and subassembly K05555. The diamond (◆) indicates that S04444-4 is not available except in subassembly A03333. Subassembly K05555 includes parts M06666 and F07777-77. The diamond (◆) indicates M06666 is not available except in subassembly K05555.

6.1 Sample Assembly				
REF	DESCRIPTION (◆ Indicates Parts Available In Assemblies Only)	PART #	QTY.	
	SAMPLE ASSEMBLY, COMPLETE (INCLUDES ALL INDENTED PARTS BELOW)	A01111	1	
1	Sample Part	F02222-22	1	
2	Sample Subassembly (Includes All Indented Parts Below)	A03333	1	
	Sample Part (◆ Indicates Part Is Only Available With A03333)	S04444-4	1	◆
3	Sample Subassembly (Includes All Indented Parts Below)	K05555	1	
	Sample Part (◆ Indicates Part Is Only Available With K05555)	M06666	2	◆
4	Sample Part	F07777-77	1	

To Order Parts:

- From Europe call our European Headquarters and Manufacturing Facility in Kolo, Poland at **+48-63-2626000** or **+48-3912-1319**. From the continental U.S., call our toll-free Parts hotline at **1-800-448-7881**. Have your customer number, vehicle identification number, and part numbers ready when you call.
- From other international locations, contact the Wood-Mizer distributor in your area for parts.

6.2 Blade Guide Assembly, Idle Side

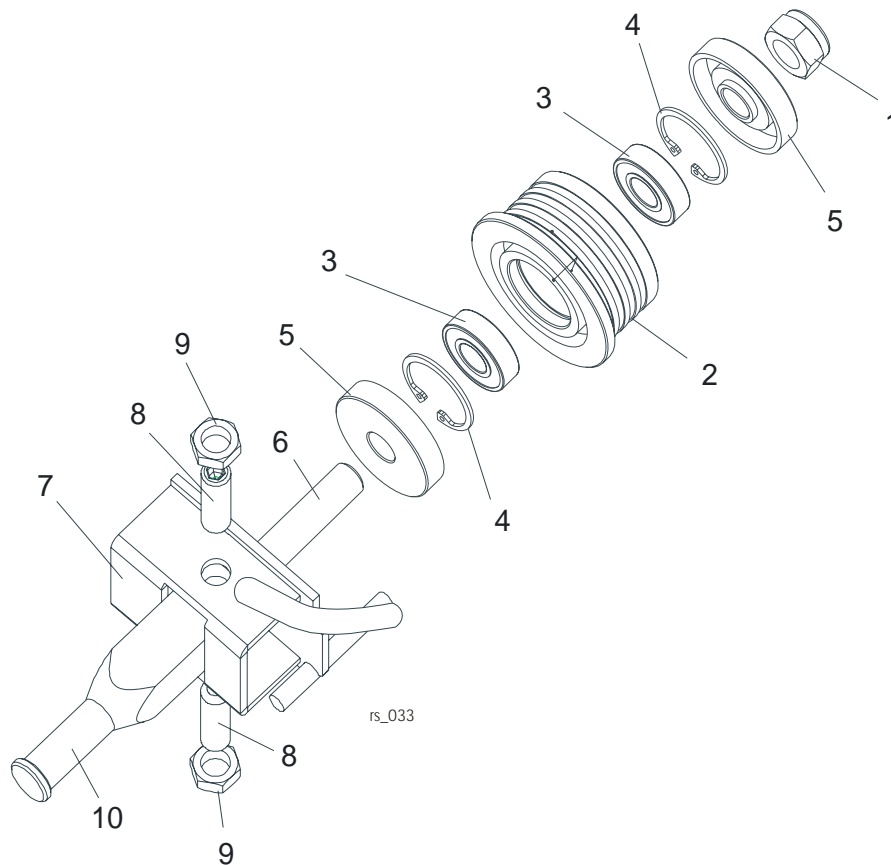

REF	DESCRIPTION (◆ Indicates Parts Available In Assemblies Only)	PART #	QTY.	
	BLADE GUIDE ASSEMBLY, HR IDLE SIDE	500500	1	
	BLADE GUIDE ROLLER, HR STANDARD COMPLETE	500499	1	
1	NUT, M12-8 HEX NYLON ZINC LOCK	F81034-2	1	
2	ROLLER, BLADE GUIDE NARROW	500098	1	◆
3	BEARING, 6001 2RSR NACHI	087893	2	
4	RING, W28 INSIDE RETAINING	F81090-9	2	
5	WASHER, ZINC-PLATED SPACER	087891-1	2	
6	SHAFT, BLADE GUIDE ROLLER ZINC-PLATED	087763-1	1	
7	BRACKET WELDMENT, IS BLADE GUIDE PAINTED	500497-1	1	
8	SCREW, M10X1X40 DIN913 STAINLESS STEEL SET	F81015-2	2	
9	NUT, M10X1-04-ST-A2 ISO 8675 THIN	F81033-10	2	
10	SHAFT, BLADE GUIDE MOUNT ZINC-PLATED	088255-1	1	

6.3 Blade Guide Assembly, Drive Side

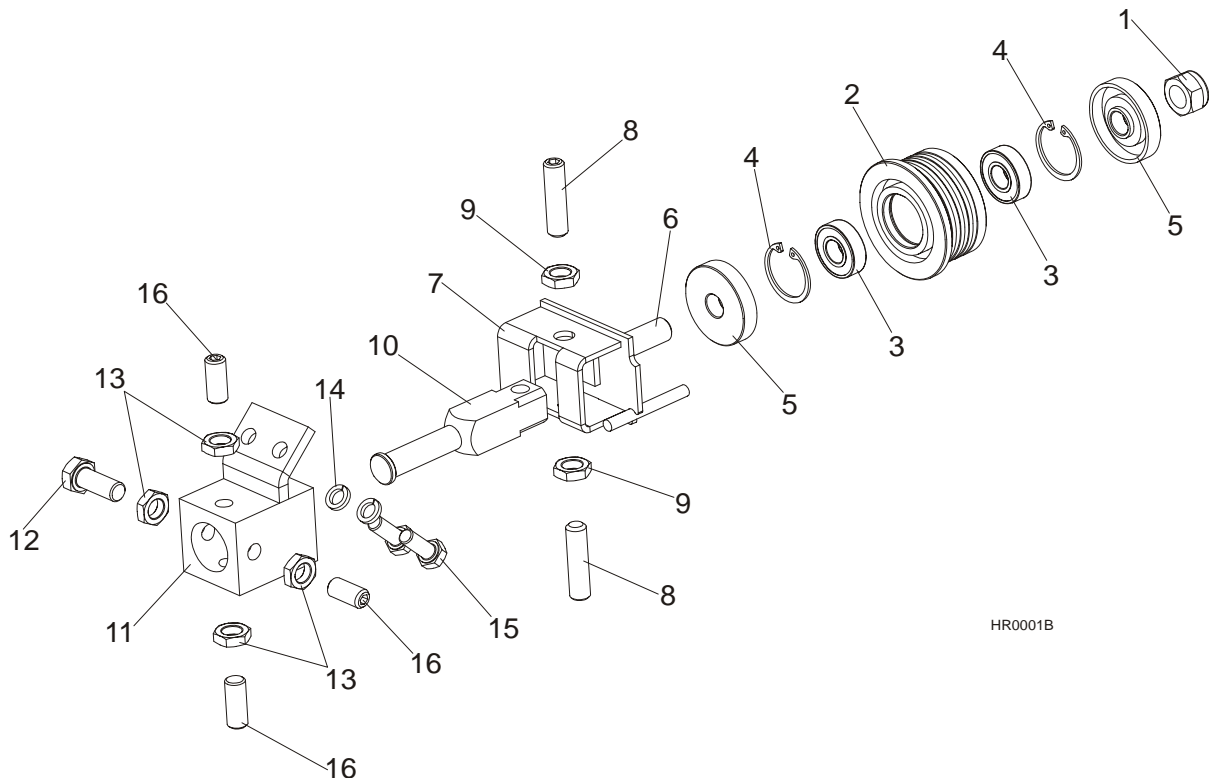

REF	DESCRIPTION (◆ Indicates Parts Available In Assemblies Only)	PART #	QTY.	
	BLADE GUIDE ASSEMBLY, HR DRIVE SIDE	500501	1	
	BLADE GUIDE ROLLER, HR STANDARD COMPLETE	500499	1	
1	NUT, M12-8 HEX NYLON ZINC LOCK	F81034-2	1	
2	ROLLER, BLADE GUIDE NARROW	500098	1	◆
3	BEARING, 6001 2RSR NACHI	087893	2	
4	RING, W28 INSIDE RETAINING	F81090-9	2	
5	WASHER, ZINC-PLATED SPACER	087891-1	2	
6	SHAFT, BLADE GUIDE ROLLER ZINC-PLATED	087763-1	1	
7	BRACKET WELDMENT, DS BLADE GUIDE PAINTED	500498-1	1	
8	SCREW, M10X1X40 DIN913 STAINLESS STEEL SET	F81015-2	2	
9	NUT, M10X1-04-ST-A2 ISO 8675 THIN	F81033-10	2	
10	SHAFT, BLADE GUIDE MOUNT ZINC-PLATED	088255-1	1	
11	BLOCK WELDMENT, BLADE GUIDE MOUNT PAINTED	088292-1	1	
12	BOLT, M10X1X25 DIN 933 STAINLESS STEEL	F81003-28	1	
13	NUT, M10X1-04-ST-A2 ISO 8675 THIN	F81033-10	4	
14	WASHER, 8.2 SPLIT LOCK ZINC	F81054-4	2	
15	BOLT, M8X20-8.8-B HEX HEAD FULL THREAD ZINC	F81002-4	2	
16	SCREW, M10X1X20 DIN913 STAINLESS STEEL SET	F81015-1	3	

6.4 Blade Guide Arm Assembly

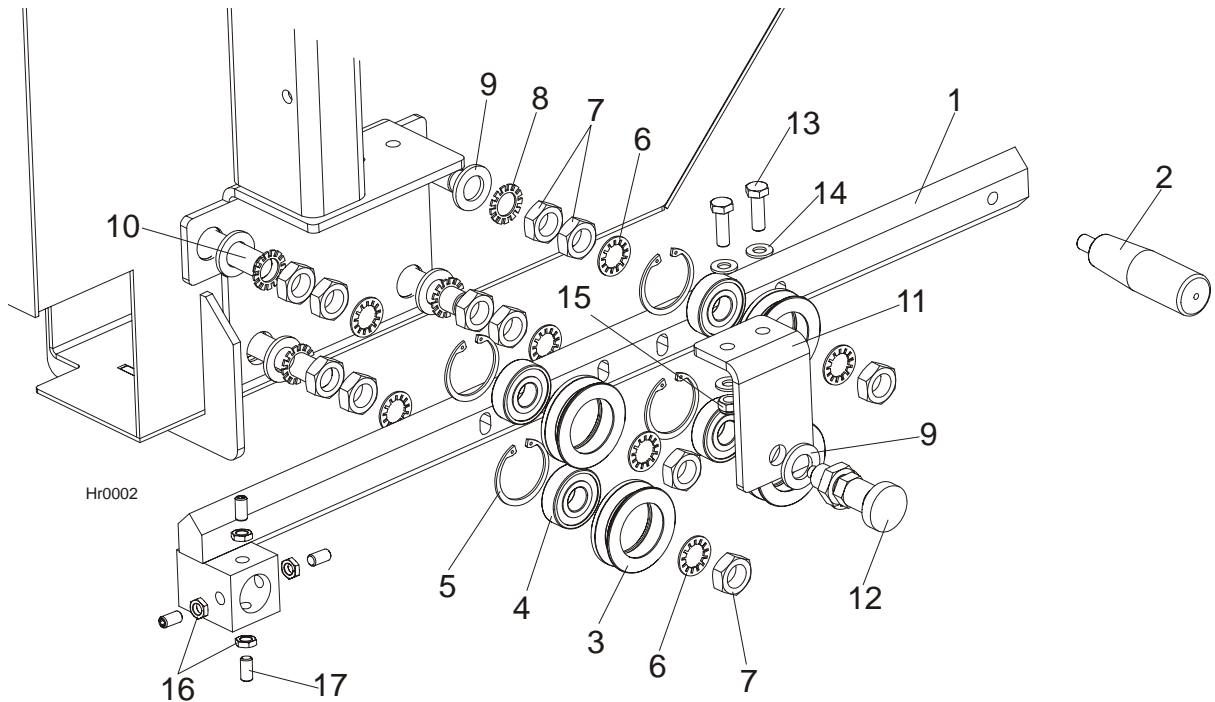

REF	DESCRIPTION (◆ Indicates Parts Available In Assemblies Only)	PART #	QTY.
1	ARM, ADJUSTABLE ZINC-PLATED BLADE GUIDE	099075-1	1
2	HANDLE, PLASTIC	086338	1
	ROLLER ASSEMBLY, V-GROOVE W/BEARING	093855	4
3	ROLLER, V-GROOVE ZINC-PLATED	093856-1	1
4	BEARING, 6203 2RSP6-5/8 CX	095087	1
5	RING, W40 INSIDE RETAINING	F81090-3	1
6	WASHER, 5/8" INTERNAL STAR	F05011-25	8
7	NUT, 5/8"-18 HEX ZINC	F05010-11	12
8	WASHER, 5/8" EXTERNAL STAR	F05011-26	4
9	WASHER, 17 FLAT ZINC	F81058-1	5
10	BOLT WELDMENT, ECCENTRIC PAINTED	086508-1	4
11	BRACKET, DETENT PIN MOUNT PTD	099077-1	1
12	PIN, 45308DNW DETENT	089939	1
13	BOLT, M8X25-8.8-B HEX HEAD FULL THREAD ZINC	F81002-5	2
14	WASHER, 8.4 FLAT ZINC	F81054-1	4
15	NUT, M8-8-B HEX NYLON ZINC LOCK	F81032-2	2
16	NUT, M10X1-04-ST-A2 ISO 8675 THIN	F81033-10	4
17	SCREW, M10X1X20 DIN913 STAINLESS STEEL SET	F81015-1	4

6.5 Drive-Side Blade Wheel Assembly

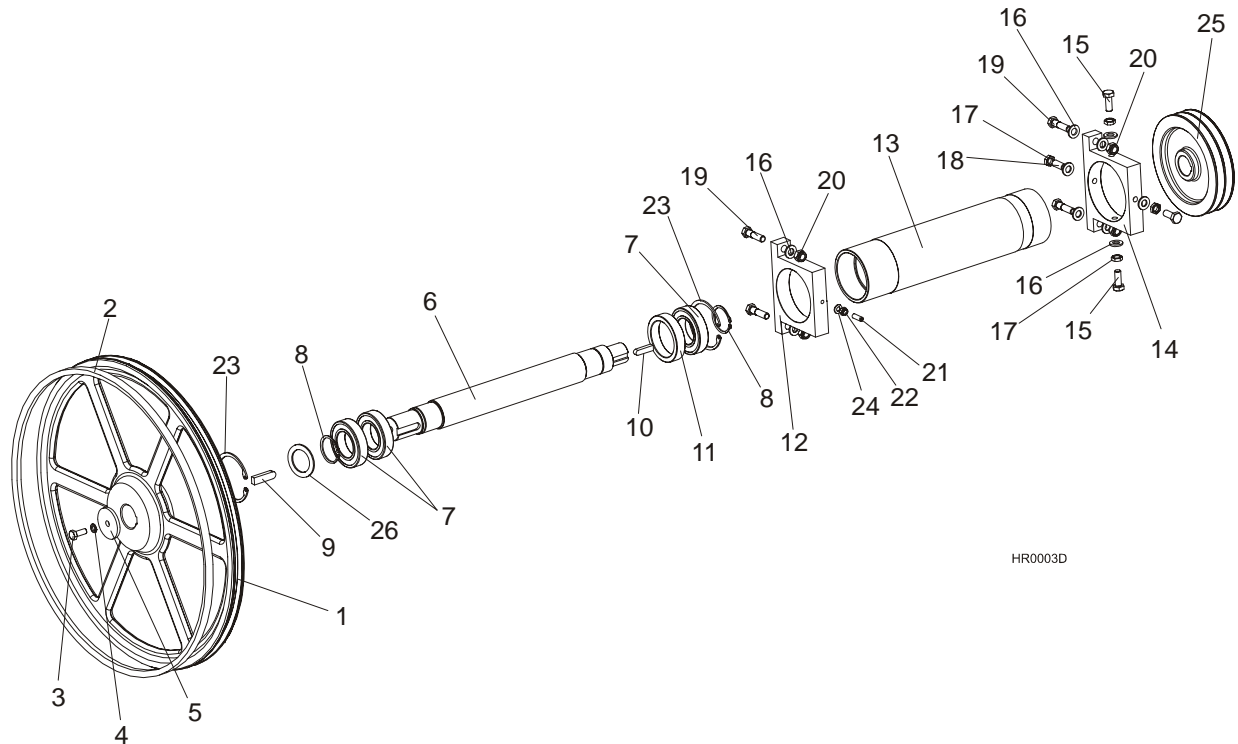

HR0003D

REF	DESCRIPTION (◆ Indicates Parts Available In Assemblies Only)	PART #	QTY.	
1	WHEEL, RESAW DRIVE-SIDE BLADE - PAINTED	093218-1	1	
2	V-BELT, B72.5	017922	1	
3	BOLT, M10X35 8.8 HEX HEAD FULL THREAD	F81003-17	1	
4	WASHER, 10.2 SPLIT LOCK ZINC	F81055-2	1	
5	WASHER, IDLE-SIDE BLADE WHEEL RETAINING ZINC-PLATED	088957-1	1	
	SHAFT ASSEMBLY, RESAW DRIVE-SIDE BLADE WHEEL	093239	1	
6	Shaft, Resaw Drive-Side Blade Wheel	093238	1	
7	Bearing, 6210 2RSR	093237	3	
8	Ring, Z50 Outside Retaining	F81090-28	2	
9	Key, AB 14x9x50 Parallel	093266	1	
10	Key, AB 10x8x40 Parallel	091990	1	
11	Bushing, Main Shaft Spacer	094439	1	
12	Bracket, Drive Shaft Adjustment Zinc-Plated	093255-1	1	
13	Bushing, Drive Shaft Housing Painted	093234-1	1	
14	Bracket, Drive Shaft Bushing Mount Zinc-Plated	094535-1	1	
15	Bolt, M12x1.25x30 DIN933 A2-70 Stainless Steel	F81004-44	3	
16	Washer, 13 Flat Zinc	F81056-1	4	
17	Nut, M12x1.25 DIN439 Thin Stainless Steel	F81034-9	4	
18	Screw, M12x1.25x30 DIN913 Stainless Steel Set	F81016-1	1	
19	Bolt, M12x45-8.8 Hex Head Zinc	F81004-32	4	
20	Nut, M12-8 Hex Nylon Zinc Lock	F81034-2	4	

21	Screw, M8x25 A2-70 DIN 913 Stainless Steel Set	F81014-3	1	
22	Nut, M8-8-B Hex Nylon Zinc Lock	F81032-2	1	
23	Ring, W90 Inside Retaining	F81090-29	2	
24	WASHER, 8.4 FLAT ZINC	F81054-1	1	
25	PULLEY, SPB Φ224X2/Φ38 (F02312+T31124)	500177	1	
	PULLEY, SPB Φ190X2/Φ38 (F02347+T31124)	500569	1	
26	WASHER, 45X65X3 SPECIAL ZINC-PLATED	100943-1	1	

6.6 Idle-Side Blade Wheel Assembly

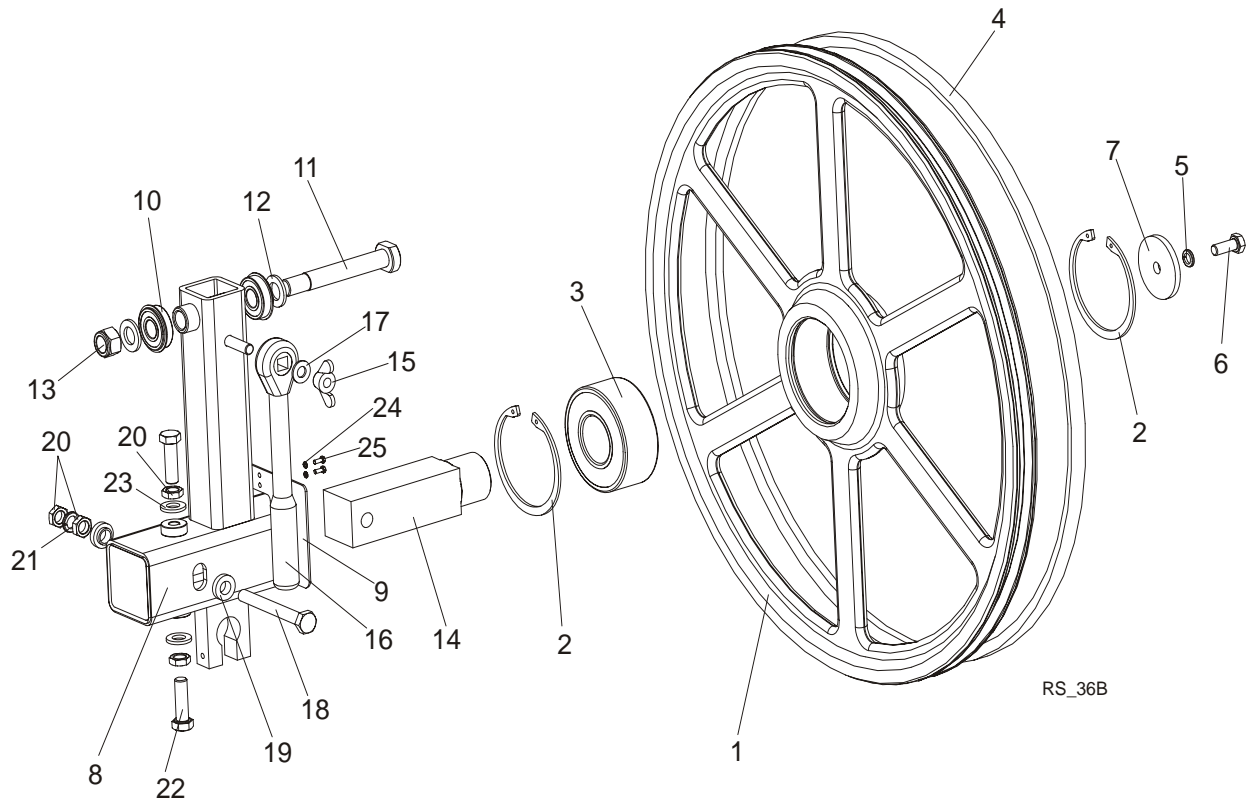

REF	DESCRIPTION (◆ Indicates Parts Available in Assemblies Only)	PART #	QTY.	
	WHEEL, IDLE-SIDE BLADE - COMPLETE	088764	1	
1	Wheel, Idle-Side Blade Ptd	090810	1	
2	Ring, W100 Inside Retaining	F81090-10	2	
3	Bearing, 3309B.2RSR.TVH FAG	086428	1	
4	V-BELT, B72.5	017922	1	
5	WASHER, 10.2 SPLIT LOCK ZINC	F81055-2	1	
6	BOLT, M10X25 8.8 HEX HEAD FULL THREAD	F81003-31	1	
7	WASHER, IDLE-SIDE WHEEL RETAINING ZINC-PLATED	088957-1	1	
8	ARM WELDMENT, RESAW & TVS IDLE SIDE BLADE WHEEL	098606-1	1	
9	GUARD, IDLE SIDE BLADE WHEEL ARM	088442-1	1	
10	BEARING, 6203-2RS NR NSK W/SNAP RING	086395	2	
11	BOLT, ARM BEARING MOUNT	086404	1	
12	WASHER, 17 FLAT ZINC	F81058-1	2	
13	NUT, M16-8 HEX NYLON ZINC LOCK	F81036-2	1	
14	SHAFT, IDLE-SIDE BLADE WHEEL	088474	1	
15	NUT, M10 WING ZINC	F81033-8	1	
16	WRENCH, LT20 BLADE TENSION	091620	1	
17	WASHER, 10.5 FLAT ZINC	F81055-1	1	
18	BOLT, M12X1.25X100-8.8 HEX HEAD FULL THREAD ZINC	F81004-41	1	

REPLACEMENT PARTS

Idle-Side Blade Wheel Assembly

6

19	WASHER, FLANGED ZINC-PLATED	086769-1	2	
20	NUT, M12X1.25 8.8 THIN ZINC	F81034-5	4	
21	WASHER, Z12.2 SPLIT LOCK ZINC	F81056-2	1	
22	BOLT, M12X1.25X40-8.8 HEX HEAD ZINC	F81004-42	2	
23	WASHER, 13 FLAT ZINC	F81056-1	2	
24	BOLT, M5X12-5.8 HEX HEAD FULL THREAD ZINC	F81000-5	2	
25	WASHER, 5.1 SPLIT LOCK ZINC	F81052-2	2	

6.7 Blade Tensioner Assembly

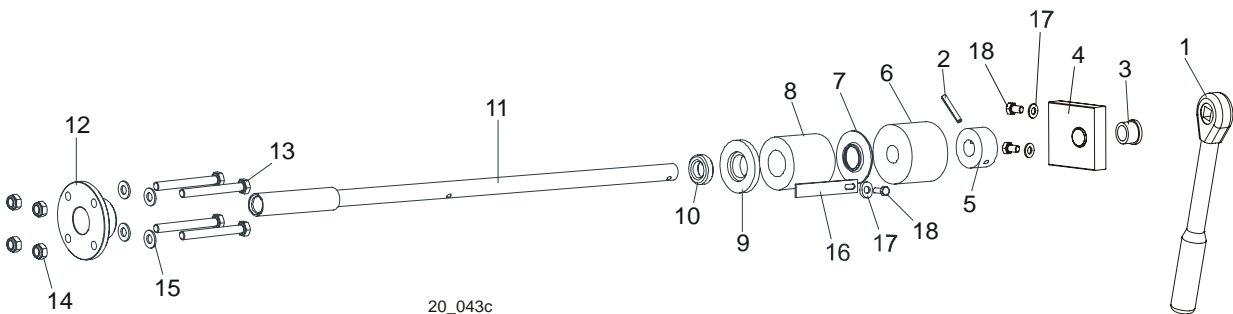

REF	DESCRIPTION (◆ Indicates Parts Available In Assemblies Only)	PART#	QTY.
	BLADE TENSIONER ASSEMBLY	090587	1
1	Wrench, LT20 Blade Tension	091620	1
2	Pin, 5 x 30 Zinc Roll	F81044-21	1
	Bracket, Tension Handle Mount w/Bushing	096729	1
3	Bushing GFM-1618-17(IGUS)	089589	1
4	Bracket, Painted	096730	1
5	Collar, Blade Tensioner	086712-1	1
6	Bushing, Rubber Stop	P12165	1
7	Guide, LT15 Tension Handle	014925	1
8	Spring, LT15 Rubber Blade Tensioner	014828	1
9	Washer, Rubber Spring Front	086674-1	1
10	Bearing, 51103 FLT Ball Thrust	086675	1
11	Shaft Weldment, Blade Tensioner Zinc-plated	101338-1	1
12	Nut, Blade Tensioner	086672-1	1
13	Bolt, M8x70 8.8 Hex Head Zinc	F81002-71	4
14	Nut, M8-8-B Hex Nylon Zinc Lock	F81032-2	4
15	Washer, 8.4 Zinc Flat	F81054-1	8
16	Indicator, LT15 Blade Tension Zinc-plated	092467-1	1
17	Washer, 6.4 Zinc Flat	F81053-1	1
18	Bolt, M6x16 8.8 Hex Head Full Thread Zinc	F81001-15	1

6.8 Middle Throat Screw

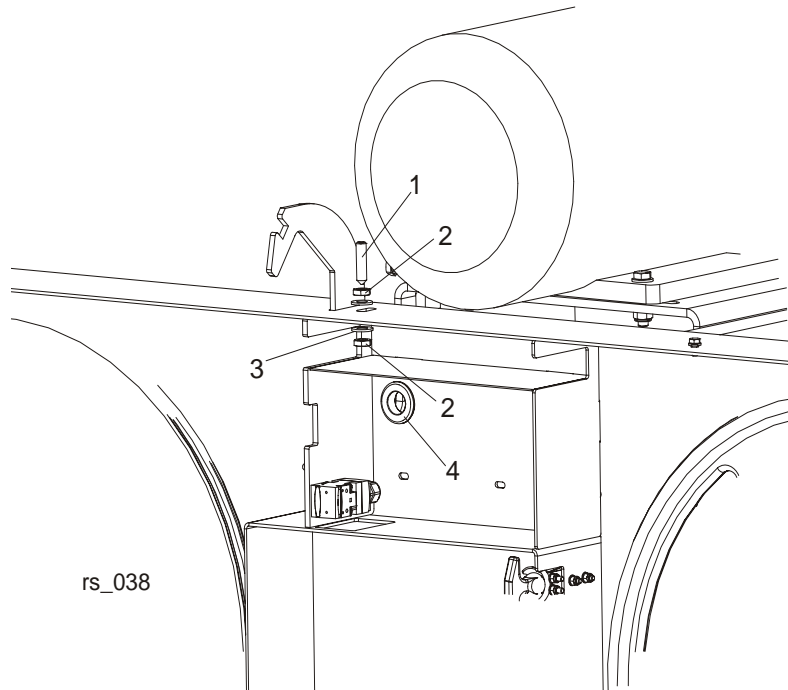

REF	DESCRIPTION (◆ Indicates Parts Available in Assemblies Only)	PART #	QTY.	
1	SCREW, M10X40-45H HEX SOCKET SET CONE POINT ZINC	F81003-61	1	
2	NUT, M10-8-B HEX ZINC	F81033-6	2	
3	WASHER, 10.5 FLAT ZINC	F81055-1	2	
4	GROMMET, 22 MM DIA. RUBBER	087400	1	

6 REPLACEMENT PARTS

Water Bottle Assembly

6.9 Water Bottle Assembly

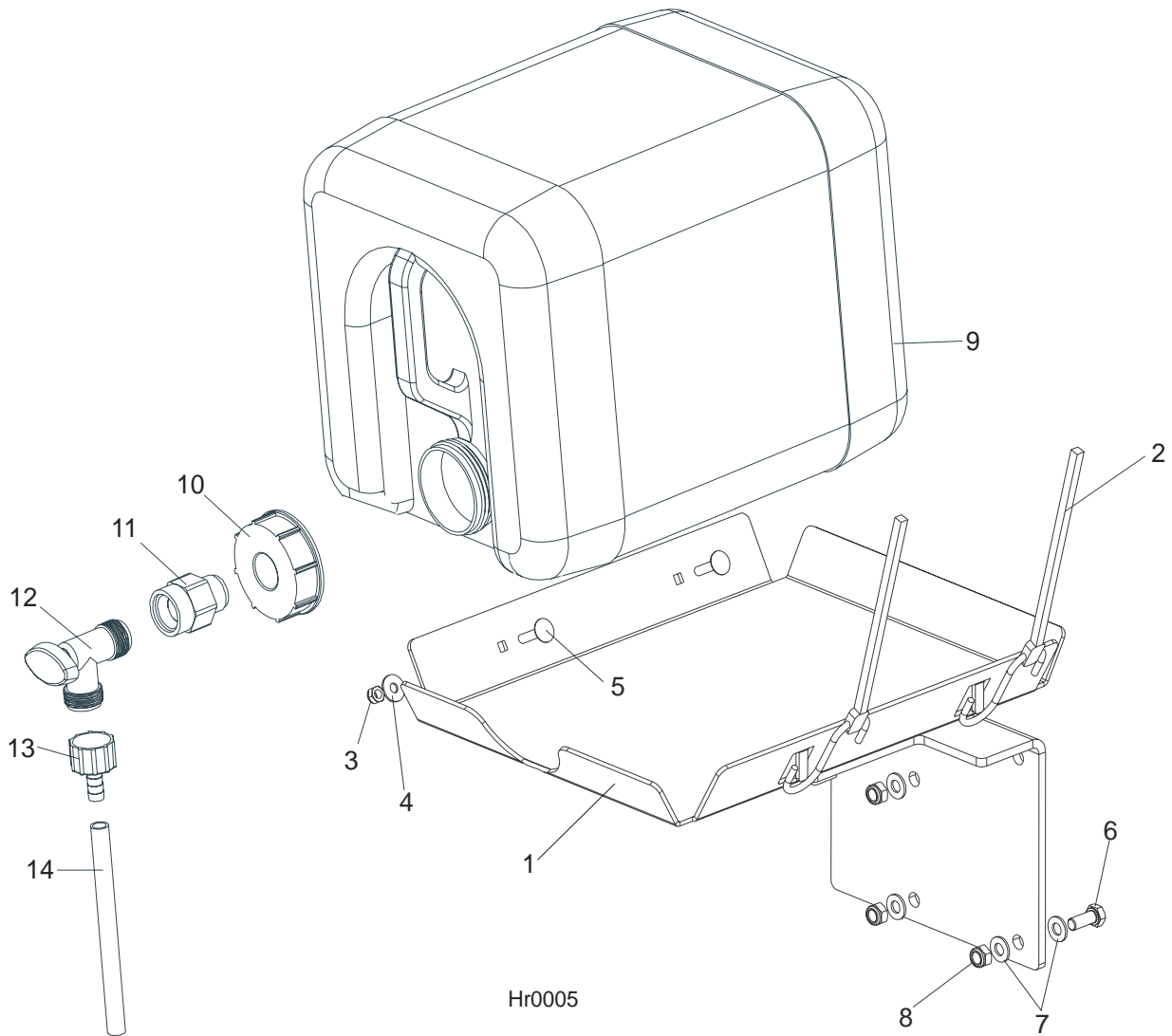

REF	DESCRIPTION (◆ Indicates Parts Available In Assemblies Only)	PART #	QTY.	
	BOTTLE KIT, WATER LUBE - COMPLETE	091036	1	
1	Tray Weldment, Water Bottle Ptd	091033-1	1	
2	Strap, 20" Rubber w/Hook	P11668	2	
3	Nut, M6-8-B Hex Nylon Zinc Lock	F81031-2	2	
4	Washer, 6.5 Special Flat Zinc	F81053-11	2	
5	Bolt, M6x25-8.8 Mushroom Head Square Neck Zinc	F81001-20	2	
6	Bolt, M8x20-5.8 Hex Head Full Thread Zinc	F81002-1	3	
7	Washer, 8.4 Flat Zinc	F81054-1	6	
8	Nut, M8-8-B Hex Nylon Zinc Lock	F81032-2	3	
	Bottle Kit, Water Lube	014642	1	
9	Bottle, 5-Gallon Water	014637	1	

REPLACEMENT PARTS*Water Bottle Assembly***6**

10	Cap, Water Lube Bottle Butress Thread	014773	1	
	Cap, Water Bottle Fine Thread	014754	1	
11	Fitting, 3/4FPT x 3/4MPT	014636	1	
12	Valve, 3/4 NPT Elbow 3/4 Male Outlet PCV	014100	1	
13	Reducer, 5/8 NPT/3/8 Barb Water Lube	014113	1	
14	Tubing, Water Lube	R01885	2.1 m	

6.10 Saw Head Warning Decals

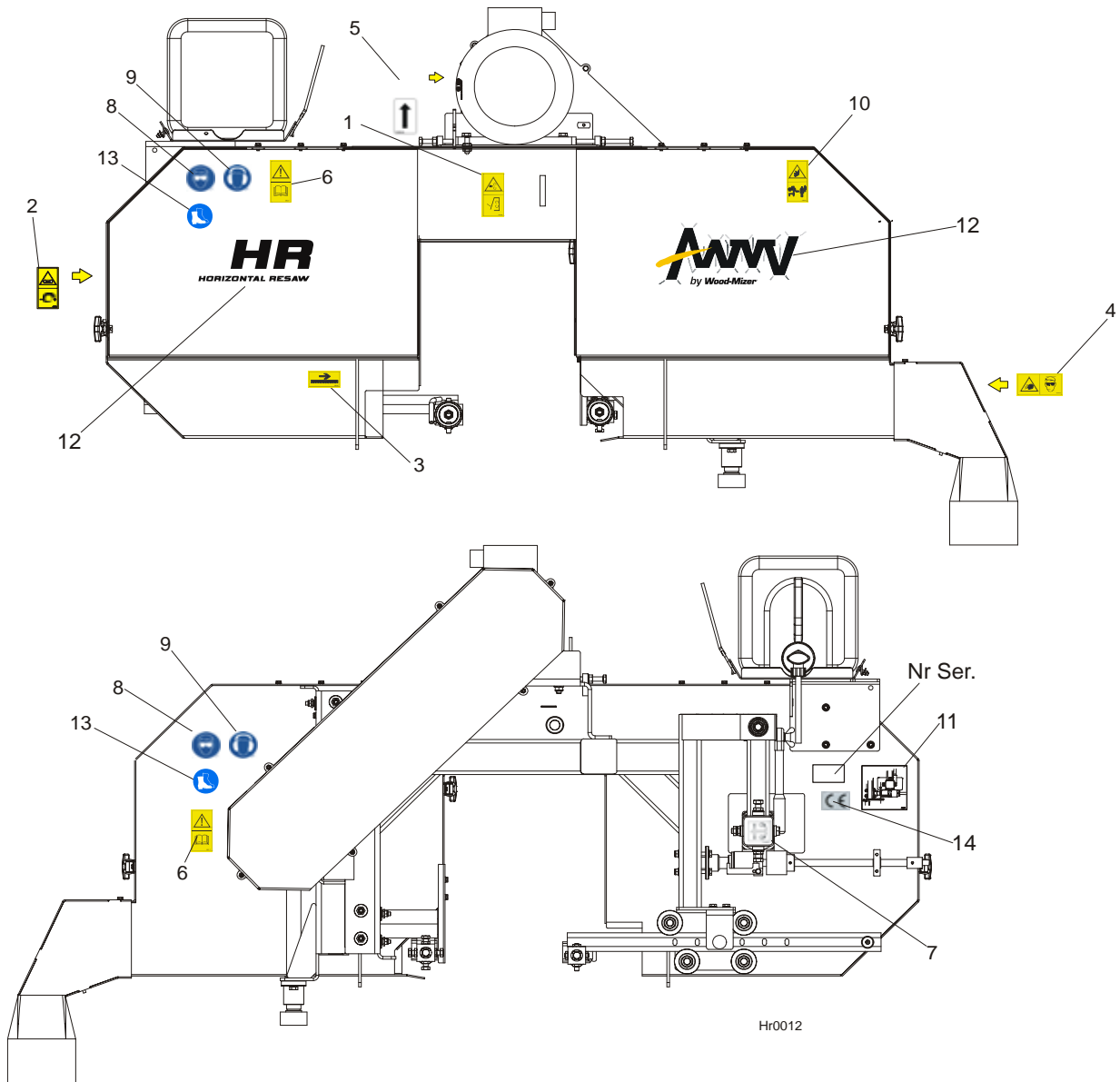

Hr0012

REF	DESCRIPTION (◆ Indicates Parts Available in Assemblies Only)	PART #	QTY.
	DECAL KIT FOR HR1	099821	1
1	DECAL, SAWMILL COVERS CAUTION	099220	1
2	DECAL, BLADE TENSION (PICTOGRAM)	099219	1
3	DECAL, BLADE MOVEMENT DIRECTION (PICTOGRAM)	096321	1
4	DECAL, SAWDUST CHUTE WARNING (PICTOGRAM)	099222	1
5	DECAL, MOTOR ROTATION DIRECTION	S20097	1
6	DECAL, READ THE OPERATOR'S MANUAL (PICTOGRAM)	096317	2
7	DECAL, BLADE ALIGNMENT	P11789	1
8	DECAL, EYE PROTECTION WARNING (PICTOGRAM)	S12004G	2

REPLACEMENT PARTS

Saw Head Warning Decals

6

9	DECAL, EAR PROTECTION WARNING (PICTOGRAM)	S12005G	2	
10	DECAL, KEEP A SAFE DISTANCE AWAY (PICTOGRAM)	099221	1	
11	DECAL, BLADE TENSION INDICATOR ADJUSTMENT (PICTOGRAM)	092597	1	
12	DECAL KIT, "HR" MACHINE NAME	099585	1	
	DECAL KIT FOR HR2	099822	1	
	DECAL KIT FOR HR1	099821	2	
	DECAL KIT FOR HR3	099823	1	
	DECAL KIT FOR HR1	099821	3	
	DECAL KIT FOR HR4	099824	1	
	DECAL KIT FOR HR1	099821	4	
	DECAL KIT FOR HR5	099825	1	
	DECAL KIT FOR HR1	099821	5	
	DECAL KIT FOR HR6	099826	1	
	DECAL KIT FOR HR1	099821	6	

6.11 Blade Housing Cover

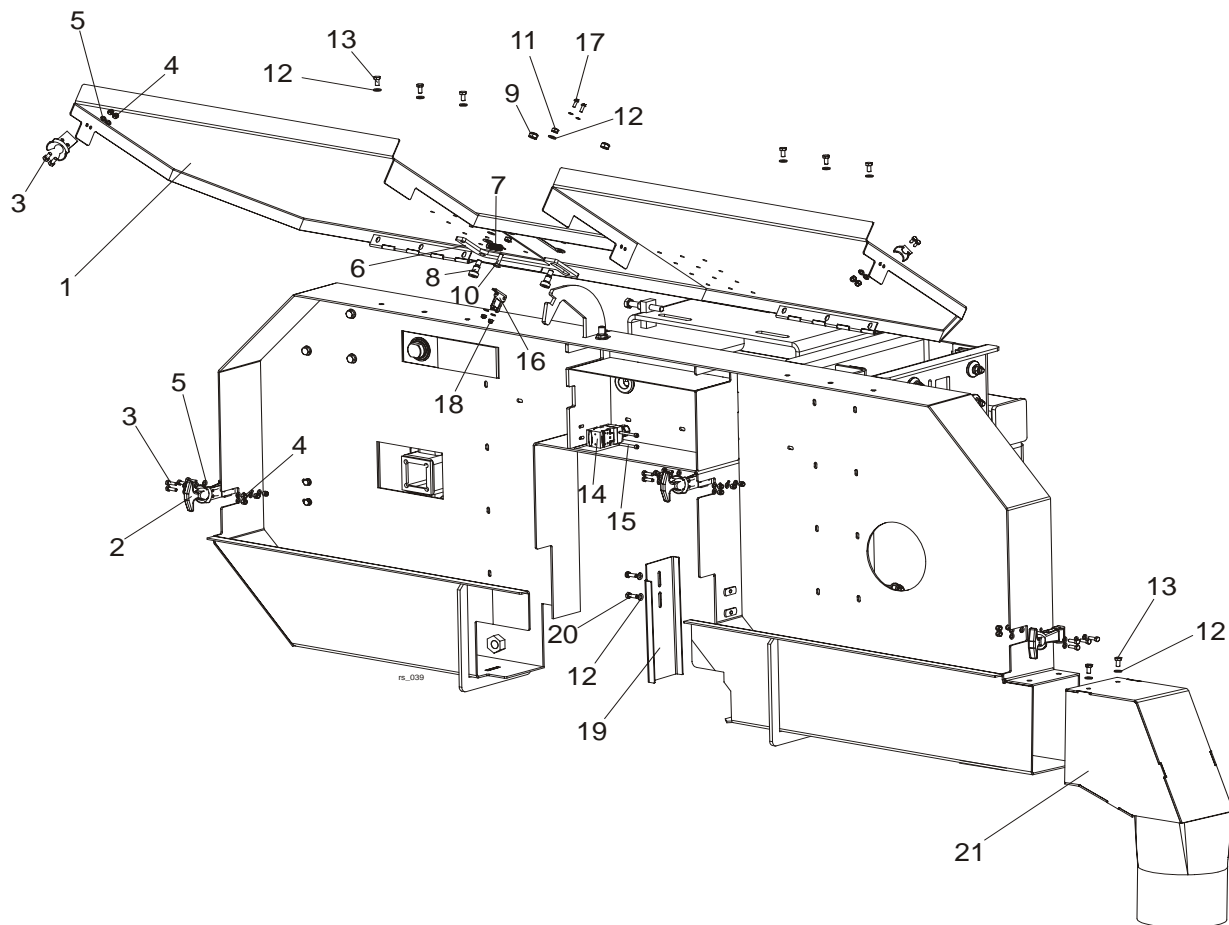

REF	DESCRIPTION (◆ Indicates Parts Available In Assemblies Only)	PART #	QTY.	
1	COVER WELDMENT, RESAW BLADE HOUSING	093251-1	1	
2	LATCH, FLEXIBLE DRAW	014829	3	
3	BOLT, M5X16-5.8 HEX HEAD FULL THREAD ZINC	F81000-51	12	
4	NUT, M5-8-FE/ZN5 DIN 985	F81030-2	12	
5	WASHER, 5.3 FLAT ZINC	F81052-1	24	
6	PAWL, LOCKING PAINTED	090643-1	1	
7	SPRING, 1.6X12X38 EXTENSION	092208	1	
8	BOLT, 10/M8X12-12.9 ISO-7379 SHOULDER	F81003-62	2	
9	NUT, M8-8-B HEX NYLON ZINC LOCK	F81032-2	2	
10	BOLT, M6X20-8.8 HEX HEAD FULL THREAD ZINC	F81001-2	1	
11	NUT, M6-8-B HEX NYLON ZINC LOCK	F81031-2	2	
12	WASHER, 6.4 FLAT ZINC	F81053-1	12	
13	BOLT, M6X12-8.8 HEX HEAD FULL THREAD ZINC	F81001-7	8	
14	SWITCH, AZ17-11ZRK SAFETY	094232	1	
15	SCREW, M4X35 -8.8 HEX SOCKET HEAD CAP ZINC	F81011-34	2	
16	KEY, AZ17/170-B5 SAFETY SWITCH	094422	1	
17	SCREW, M4X12-5.8-B CROSS RECESSED PAN HEAD ZINC	F81011-43	2	

REPLACEMENT PARTS

Blade Housing Cover

6

18	NUT, M4-B HEX NYLON ZINC LOCK	F81029-1	2	
19	GUARD, BLADE GUIDE ROLLER PAINTED	094737-1	1	
20	BOLT, M6X16 8.8 HEX HEAD FULL THREAD ZINC	F81001-15	2	
21	CHUTE, RESAW SAWDUST	094059-1	1	

6.12 Control Box

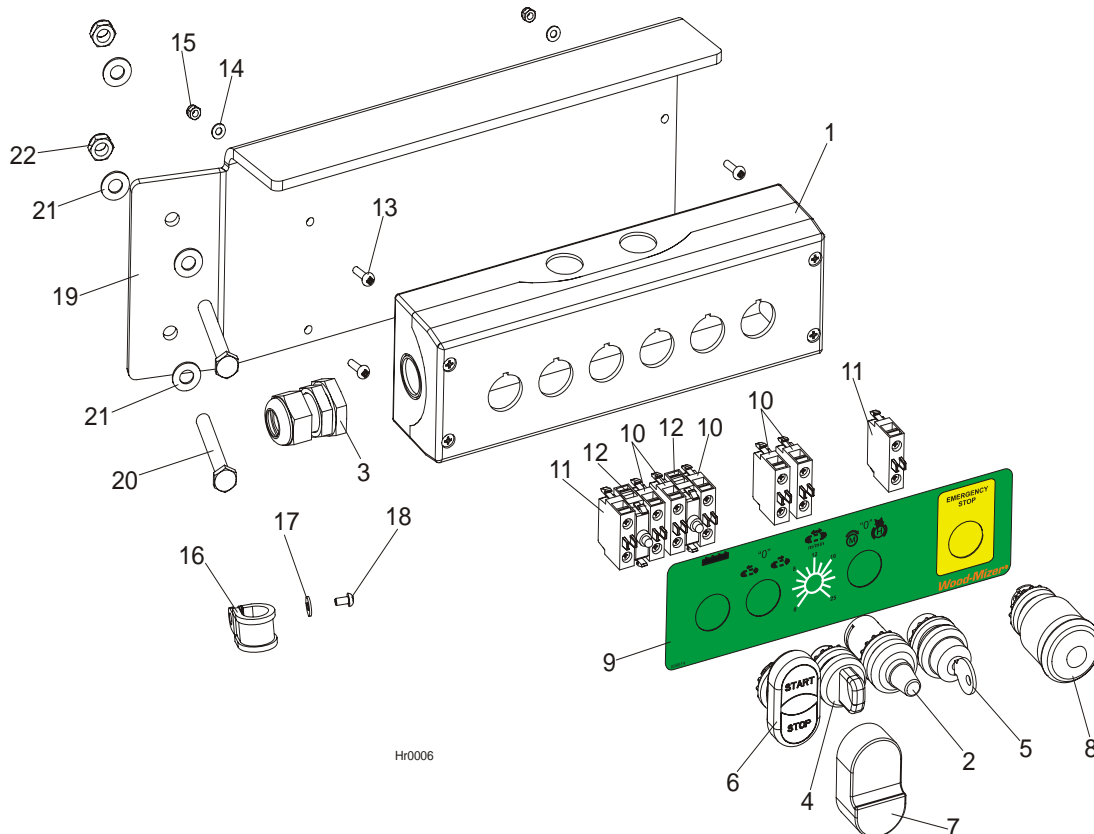

HR0006

REF	DESCRIPTION (◆ Indicates Parts Available In Assemblies Only)	PART #	QTY.
	BOX, RESAW & HR CONTROL	093458	1
1	BOX, M22-I6 (216540) CONTROL	093750	1
2	POTENTIOMETER, M22-R1K (229489)	093749	1
3	GLAND, DP 16/H CABLE	F81096-7	1
4	SWITCH, M22 - 3 POSITION	091360	1
5	OPERATOR, M22-WRS3 KEY SWITCH	095001	1
6	OPERATOR, M22-DDI-GR-GB1/GB0 SWITCH	094997	1
7	MEMBRANE, M22-T-DD	090462	1
8	OPERATOR, M22 - PVT EMERGENCY STOP SWITCH	099599	1
9	DECAL, HR CONTROL BOX	099514	1
10	ELEMENT, M22-KC10 CONTACT	094314	5
11	ELEMENT, M22-KC01 CONTACT	094998	2
12	ELEMENT, LED M22-LEDC-W	094999	2
13	SCREW, M4X16 5.8-B CROSS RECESSED PAN HEAD ZINC	F81011-42	4
14	WASHER, 4.3 FLAT ZINC	F81051-2	4
15	NUT, M4-B HEX NYLON ZINC LOCK	F81029-1	4
16	GUARD, RSGU 1.20/20 W1 WRAP-AROUND	F81087-2	7
17	WASHER, 5.5 SPECIAL FLAT ZINC	F81052-3	7
18	SCREW, H M5X10 8.8 CROSS RECESSED PAN HEAD ZINC	F81000-13	7

19	BRACKET, CONTROL BOX	099371-1	1	
20 ¹	BOLT, M8X80-8.8 HH ZINC	F81002-18	2	
	BOLT, M8 X 100 -8.8- FE/ZN5 HEX HEAD	F81002-23	2	
21	WASHER, 8.4 FLAT, ZINC	F81054-1	4	
22	NUT, M8-8-B, HEX, NYLON LOCK ZINC	F81032-2	2	

¹ Used interchangeably depending on control panel position.

6.13 Saw Head Height Adjustment Screw

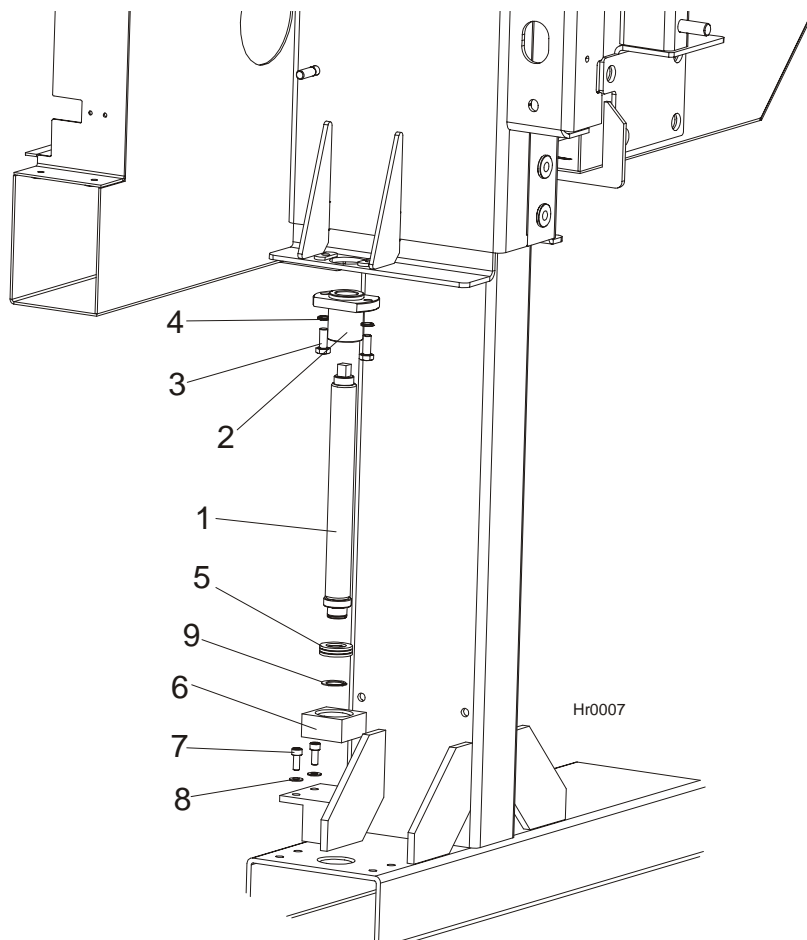

REF	DESCRIPTION (◆ Indicates Parts Available In Assemblies Only)	PART #	QTY.	
1	SCREW, ACME ZINC-PLATED (SAW HEAD HEIGHT ADJUSTMENT)	093263-1	1	
2	NUT, ACME SCREW FLANGED ZINC-PLATED	093264-1	1	
3	BOLT, M10X25 8.8 HEX HEAD FULL THREAD	F81003-31	2	
4	WASHER, 10.2 SPLIT LOCK ZINC	F81055-2	2	
5	BEARING, 51105 THRUST	088033	1	
6	BLOCK, ACME SCREW REST ZINC-PLATED	093265-1	1	
7	SCREW, M8X20-8.8 HEX SOCKET SET CAP ZINC	F81002-30	2	
8	WASHER, 8.2 SPLIT LOCK ZINC	F81054-4	2	
9	RING, 25Z OUTSIDE RETAINING	F81090-22	1	

6.14 Mast Tilt Adjustment Screw

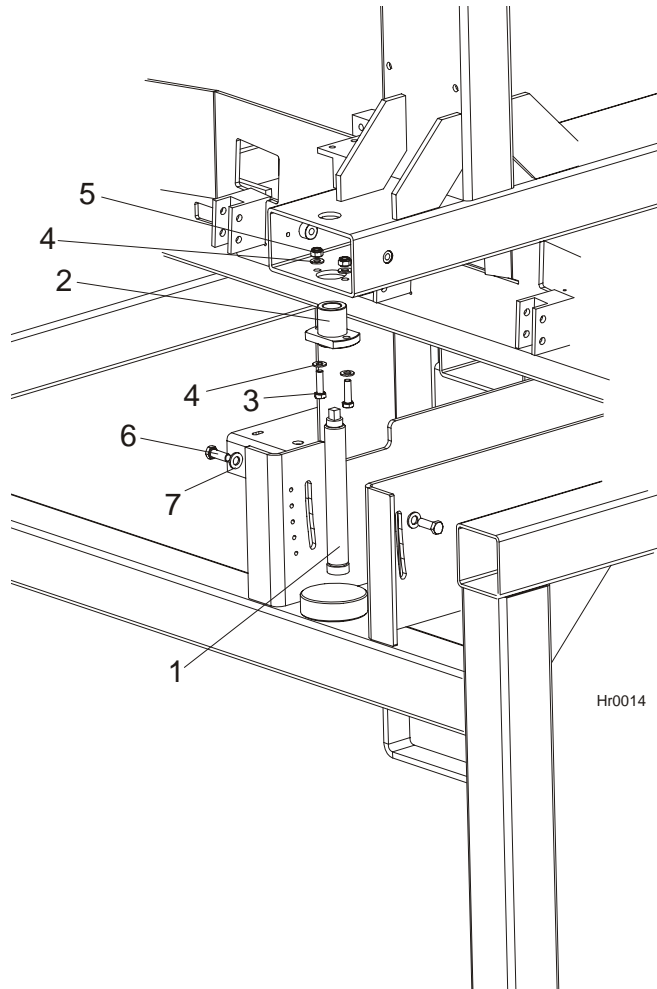

REF	DESCRIPTION (◆ Indicates Parts Available in Assemblies Only)	PART #	QTY.
1	SCREW, MAST TILT ADJUSTMENT ACME	093509-1	1
2	NUT, ACME SCREW FLANGED ZINC-PLATED	093264-1	1
3	BOLT, M10X35-8.8 HEX HEAD FULL THREAD ZINC	F81003-17	2
4	WASHER, 10.5 FLAT ZINC	F81055-1	4
5	NUT, M10-8-B HEX NYLON ZINC LOCK	F81033-1	2
6	BOLT, M12X35-8.8 HEX HEAD FULL THREAD ZINC	F81004-24	2
7	WASHER, 13 FLAT ZINC	F81056-1	2

6.15 Vertical Mast Slide Pads

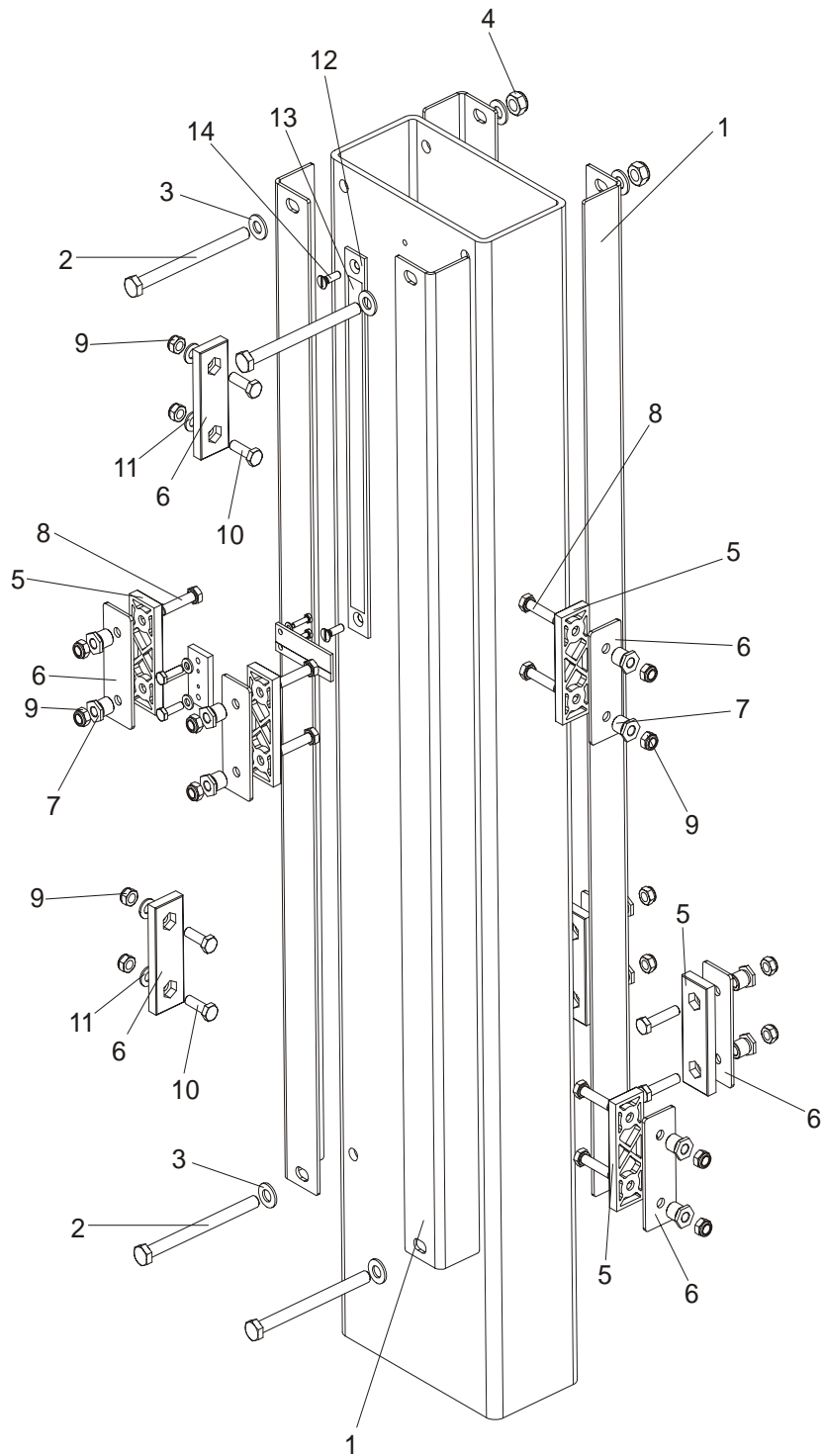

REF	DESCRIPTION (◆ Indicates Parts Available In Assemblies Only)	PART #	QTY.	
1	ANGLE, VERTICAL MAST TUBE	093890	4	
2	BOLT, M10X125-8.8 HEX HEAD ZINC	F81003-18	4	
3	WASHER, 10.5 FLAT ZINC	F81055-1	8	

REPLACEMENT PARTS

Vertical Mast Slide Pads

6

4	NUT, M10-8-B HEX NYLON ZINC LOCK	F81033-1	4	
5	PADS, DELRIN UP/DOWN SLIDE	M04096	8	
6	PLATE, SLIDE PAD MOUNTING PAINTED	093246-1	6	
7	NUT, SLIDE PAD ADJUSTMENT ZINC-PLATED	086683-1	12	
8	BOLT, M8X35-8.8 HEX HEAD FULL THREAD ZINC	F81002-13	12	
9	NUT, M8-8-B HEX NYLON ZINC LOCK	F81032-2	16	
10	BOLT, M8X25-8.8-B HEX HEAD FULL THREAD ZINC	F81002-5	4	
11	WASHER, 8.4 FLAT ZINC	F81054-1	4	
	SCALE, RESAW BLADE HEIGHT-COMPLETE	094820	1	
12	Bar, Resaw Blade Height Scale	094818	1	
13	Scale, 0-30 cm Resaw Metric	094819	1	
14	SCREW, M6X20- 4.8-B SLOTTED COUNTERSUNK HEAD ZINC	F81001-31	2	

6.16 Motor Assembly

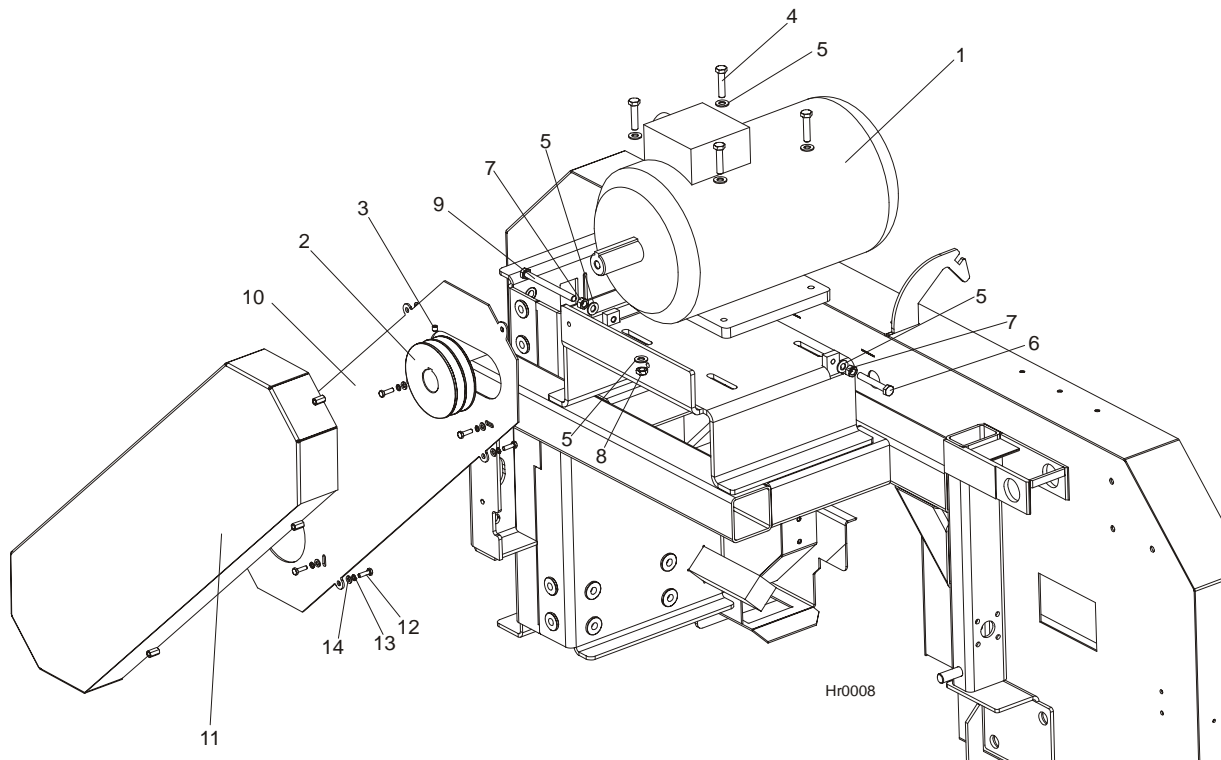

REF	DESCRIPTION (◆ Indicates Parts Available in Assemblies Only)	PART #	QTY.
1	MOTOR, 7,5kW Sg132M-4B - HM	094996	1
	MOTOR, 11kW Sg132M-4PC - HM	093219	1
2	PULLEY, SPB $\Phi 100X2/\Phi 38$ (F02312+T31079)	500176 ¹	1
	PULLEY, SPB $\Phi 125X2/\Phi 38$ (F02320+F31109)	500570 ²	1
3	SCREW, M8X8-33H HEX SOCKET FLAT POINT ZINC SET	F81014-1	1
4	BOLT, M10X45-8.8 HEX HEAD FULL THREAD ZINC	F81003-3	4
5	WASHER, 10.5 FLAT ZINC	F81055-1	10
6	BOLT, M10X70-8.8 HEX HEAD FULL THREAD ZINC	F81003-20	1
7	NUT, M10-8-B HEX ZINC	F81033-3	2
8	NUT, M10-8-B HEX NYLON ZINC LOCK	F81033-1	4
9	BOLT, M10X120 8.8 HEX HEAD FULL THREAD ZINC	F81003-47	1
10	COVER, DRIVE BELT GUARD PAINTED	093259-1	1
11	GUARD WELDMENT, RESAW DRIVE BELT PAINTED	093262-1	1
12	BOLT, M6X20-8.8 HEX HEAD FULL THREAD ZINC	F81001-2	10
13	WASHER, Z 6.1 SPLIT LOCK ZINC	F81053-3	10
14	WASHER, 6.4 FLAT ZINC	F81053-1	10
	BELT, 2BX71 MOTOR DRIVE	P12949	1
	BELT, 2BX70 11kW MOTOR DRIVE (E15)	P04857-2	1

¹ Pulley (Part No. 500176) used with pulley (Part No. 500177) and drive belt (Part No. P12949) are standard equipment and let reach $v=20.5\text{m/s}$ blade linear velocity. To reach $v=24.2\text{m/s}$ blade linear velocity use pulley (Part No. 500569) with drive belt (Part No. P04857-2) instead of pulley (Part No. 500177).

² Pulley (Part No.500570) used with pulley (Part No.500569) let reach $v=30.3\text{m/s}$ blade linear velocity. Use drive belt (Part No. P04857-2).

6.17 Feed Chain Drive & Tensioner

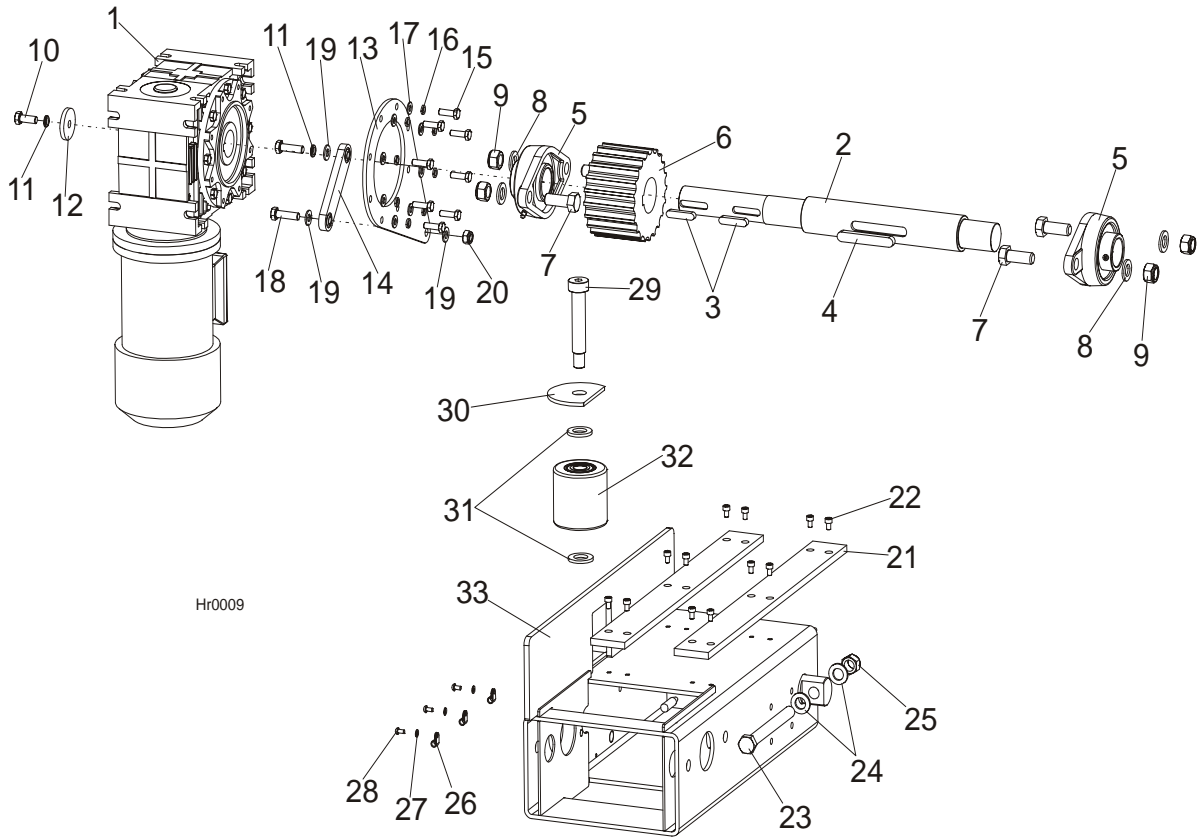

Hr0009

REF	DESCRIPTION (◆ Indicates Parts Available In Assemblies Only)	PART #	QTY.
	DRIVE ASSEMBLY, HR FEED CHAIN	099377	1
	DRIVE ASSEMBLY, HR PLATE LINK CHAIN	099069	1
1	MOTOREDUCER, MR-80/42/1.1-1400/K4/V6	099070	1
2	SHAFT, HR CHAIN DRIVE ZINC-PLATED	099335-1	1
3	KEY, A10x8x45 PARALLEL	091312	2
4	KEY, A14X9X90 PARALLEL	099424	1
5	BEARING, UCFL208 W/HOUSING	099423	2
6	SPROCKET, KZN800/21-40 A=80,B=40	099079	1
7	BOLT, M16x40-8.8 HEX HEAD FULL THREAD ZINC	F81006-13	4
8	WASHER, 17 FLAT ZINC	F81058-1	4
9	NUT, M16-8 HEX NYLON ZINC LOCK	F81036-2	4
10	BOLT, M10x25-8.8 HEX HEAD FULL THREAD ZINC	F81003-11	1
11	WASHER, 10.2 SPLIT LOCK ZINC	F81055-2	2
12	WASHER, LT15 DRIVE WHEEL ZINC-PLATED	086286-1	1
13	PLATE, RA80 MOTOREDUCER SUPPORT	099425-1	1
14	LINK, SBPL 10104 PIVOTAL	097700	1
15	BOLT, M8x25-8.8-B HEX HEAD FULL THREAD ZINC	F81002-5	8
16	WASHER, 8.2 SPLIT LOCK ZINC	F81054-4	8

17	WASHER, 8.4 FLAT ZINC	F81054-1	8	
18	BOLT, M10x35-8.8 HEX HEAD FULL THREAD ZINC	F81003-17	2	
19	WASHER, 10.5 FLAT ZINC	F81055-1	2	
20	NUT, M10-8-B HEX NYLON ZINC LOCK	F81033-1	1	
21	PAD, FEED TRACK (MEDIUM)	099376	2	
22	SCREW, M6x10 -8.8 HEX SOCKET HEAD CAP ZINC	F81001-12	12	
23	BOLT, M16x160-8.8 HEX HEAD ZINC	F81006-20	2	
24	WASHER, 17 FLAT ZINC	F81058-1	4	
25	NUT, M16-8 HEX NYLON ZINC LOCK	F81036-2	2	
26	ELEMENT, EE63 MOUNTING	F81080-4	3	
27	WASHER, 5.3 FLAT ZINC	F81052-1	3	
28	SCREW, H M5x10 8.8 CROSS RECESSED PAN HEAD ZINC	F81000-13	3	
29	BOLT, 20/M16X90 12.9 ISO7379 SHOULDER	F81006-30 ¹	1	
30	PLATE, GUIDE ROLLER COVER - ZINC-PLATED	099441-1 ¹	1	
31	WASHER, 21 FLAT ZINC	F81059-2 ¹	2	
32	ROLLER, R-80-80 (ZABI) GUIDE	099429 ¹	1	
33	MOUNT WELDMENT, HR CHAIN DRIVE	099378-1	1	

¹ Numbers of the rollers and their mounting hardware are: on HR1/2 - 12 pcs, on HR3/4 - 20 pcs, on HR5/6 - 28 pcs.

6.18 Hold-Down Rollers & Log Guide

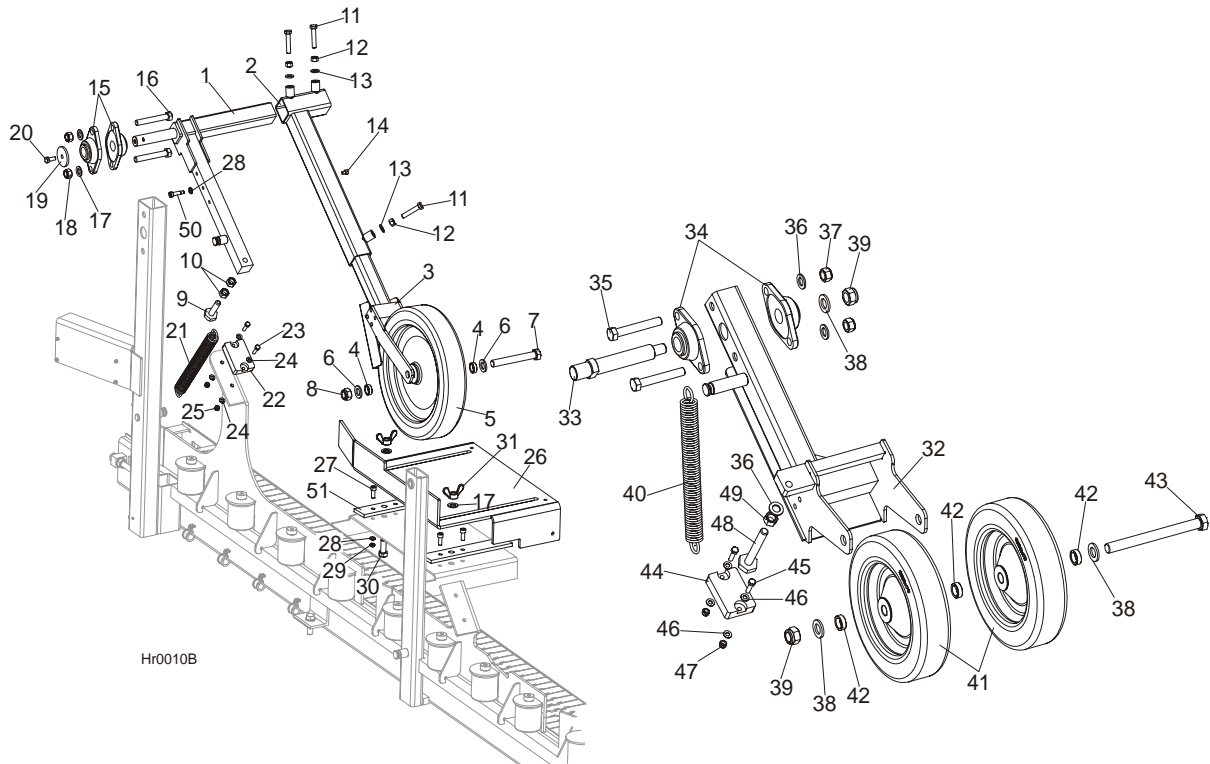

REF	DESCRIPTION (◆ Indicates Parts Available in Assemblies Only)	PART #	QTY.
	ROLLER, 400 HOLD-DOWN - COMPLETE	099347	1
1	ARM, 400 HOLD-DOWN ROLLER PIVOT	099369-1	1
2	ARM, SHR-F HOLD-DOWN ROLLER OUTSIDE	094960-1	1
3	ARM, 400 HOLD-DOWN ROLLER INSIDE	099348-1	1
4	BUSHING, 21X30X10 ZINC-PLATED SPACER	099351-1	2
5	WHEEL, 400 W/6304 BEARINGS	099334	1
6	WASHER, 21 FLAT ZINC	F81059-2	2
7	BOLT, M20x150 8.8 Fe/Zn5 ISO 4017	F81007-3	1
8	NUT, M20-8-A HEX NYLON ZINC LOCK	F81037-2	1
	M16 BED RAIL ADJUSTMENT BOLT & 2 NUTS	093710	1
9	BOLT, M16 BED RAIL ADJUSTMENT	086809	1
10	NUT, M16-5-B HEX	F81036-5	2
11	BOLT, M12x60-8.8 HEX HEAD FULL THREAD ZINC	F81004-51	3
12	NUT, M12-8-B HEX ZINC	F81034-1	3
13	WASHER, 13 FLAT ZINC	F81056-1	3
14	SCREW, M8x10-8.8 HEX SOCKET HEAD CAP ZINC	F81002-32	1
15	BEARING, UCFL 206 CX BALL	090851	2
16	BOLT, M16x110-8.8 HEX HEAD ZINC	F81006-24	2
17	WASHER, 17 FLAT ZINC	F81058-1	4
18	NUT, M16-8 HEX NYLON ZINC LOCK	F81036-2	2
19	WASHER, IDLE BLADE WHEEL RETAINING ZINC-PLATED	088957-1	1
20	BOLT, M10x25-8.8 HEX HEAD FULL THREAD ZINC	F81003-11	1

21	SPRING, FI 4,5X FI 35X303	091863	1	
22	BUMPER, GRENE 70 3201 0010. SHR RUBBER	094969	1	
23	BOLT, M8X30-5.8 HEX HEAD FULL THREAD ZINC	F81002-2	2	
24	WASHER, 8.4 FLAT ZINC	F81054-1	4	
25	NUT, M8-8-B HEX NYLON ZINC LOCK	F81032-2	2	
26	GUIDE, LOG PAINTED	099442-1	1	
27	SCREW, M10X25 8.8 HEX SOCKET HEAD CAP ZINC	F81003-32	4	
28	WASHER, 10.5 FLAT ZINC	F81055-1	4	
29	NUT, M10-8-B HEX NYLON ZINC LOCK	F81033-1	4	
30	BOLT, M16X40-8.8 HEX HEAD FULL THREAD ZINC	F81006-13	2	
31	NUT, M16 WING ZINC	F81036-3	2	
	ROLLER, 300 HOLD-DOWN DUAL COMPLETE	100344	1	
32	ARM, 300 HOLD-DOWN ROLLER	100345-1	1	
33	AXLE, 300 HOLD-DOWN ROLLER ARM	100477-1	1	
34	BEARING, UCFL 206 CX BALL	090851	2	
35	BOLT, M16x110-8.8 HEX HEAD ZINC	F81006-24	2	
36	WASHER, 17 FLAT ZINC	F81058-1	3	
37	NUT, M16-8 HEX NYLON ZINC LOCK	F81036-2	2	
38	WASHER, 21 FLAT ZINC	F81059-2	3	
39	NUT, M20-8-A HEX NYLON ZINC LOCK	F81037-2	2	
40	SPRING, FI 4.5X FI 35X303	091863	1	
41	WHEEL, FI 300 HOLD-DOWN	100349	2	
42	BUSHING, 21X30X10 ZINC-PLATED SPACER	099351-1	3	
43	BOLT, M20X220-8.8 HEX HEAD ZINC	F81007-4	1	
44	BUMPER, GRENE 70 3201 0010. SHR RUBBER	094969	1	
45	BOLT, M8x30-5.8 HEX HEAD FULL THREAD ZINC	F81002-2	2	
46	WASHER, 8.4 FLAT ZINC	F81054-1	4	
47	NUT, M8-8-B HEX NYLON ZINC LOCK	F81032-2	2	
48	BOLT, M16 HOLD-DOWN ROLLER ARM ZINC	100426-1	1	
49	NUT, M16, HEXAGON, GRADE 5.8 PLAIN	F81036-1	1	
50	BOLT, 12/M10X35 12.9 ISO7379 SOCKET HEAD	F81003-48	1	
51	WASHER, LOG GUIDE SLIDE	099478	2	

6.19 Hold-Down Adjustable Roller (Option)

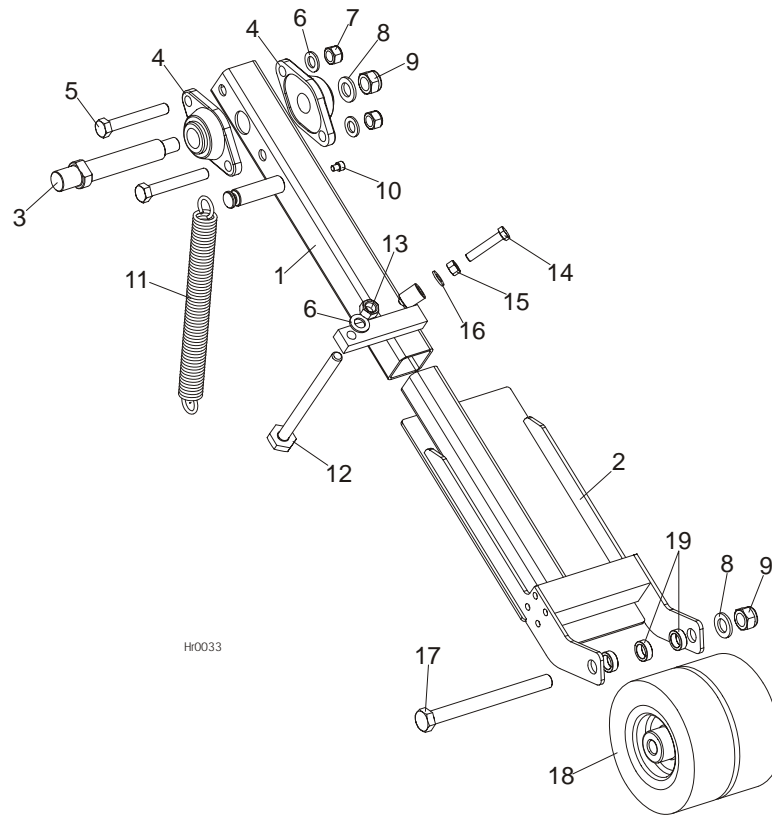

REF	DESCRIPTION (◆ Indicates Parts Available in Assemblies Only)	PART #	QTY.
	ROLLER, 200 HOLD-DOWN ADJUSTABLE	100758	1
1	ARM, 200 HOLD-DOWN ADJ. ROLLER	100587-1	1
2	ARM, 200 ADJ. ROLLER	100592-1	1
3	AXLE, 300 HOLD-DOWN ROLLER ARM	100477-1	1
4	BEARING, UCFL 206 CX BALL	090851	2
5	BOLT, M16x110-8.8 HEX HEAD ZINC	F81006-24	2
6	WASHER, 17 FLAT ZINC	F81058-1	3
7	NUT, M16-8 HEX NYLON ZINC LOCK	F81036-2	2
8	WASHER, 21 FLAT ZINC	F81059-2	2
9	NUT, M20-8-A HEX NYLON ZINC LOCK	F81037-2	2
10	SCREW, M8X10-8.8-FE/ZN5 HEX SOCKET HEAD	F81002-32	1
11	SPRING, FI 4.5X FI 35X303	091863	1
12	BOLT, M16 HOLD-DOWN ROLLER ARM ZINC	100591-1	1
13	NUT, M16, HEXAGON, GRADE 5.8 PLAIN	F81036-1	1
14	BOLT M12x60-8	F81004-51	1
15	NUT, M12-8-B ZINC HEX	F81034-1	1
16	WASHER, 13 FLAT ZINC	F81056-1	1
17	BOLT, M20X220-8.8 HEX HEAD ZINC	F81007-4	1
18	WHEEL, 200 HOLD-DOWN	099160	2
19	BUSHING, 21X30X10 ZINC-PLATED SPACER	099351-1	3

6.20 Main Base Frame

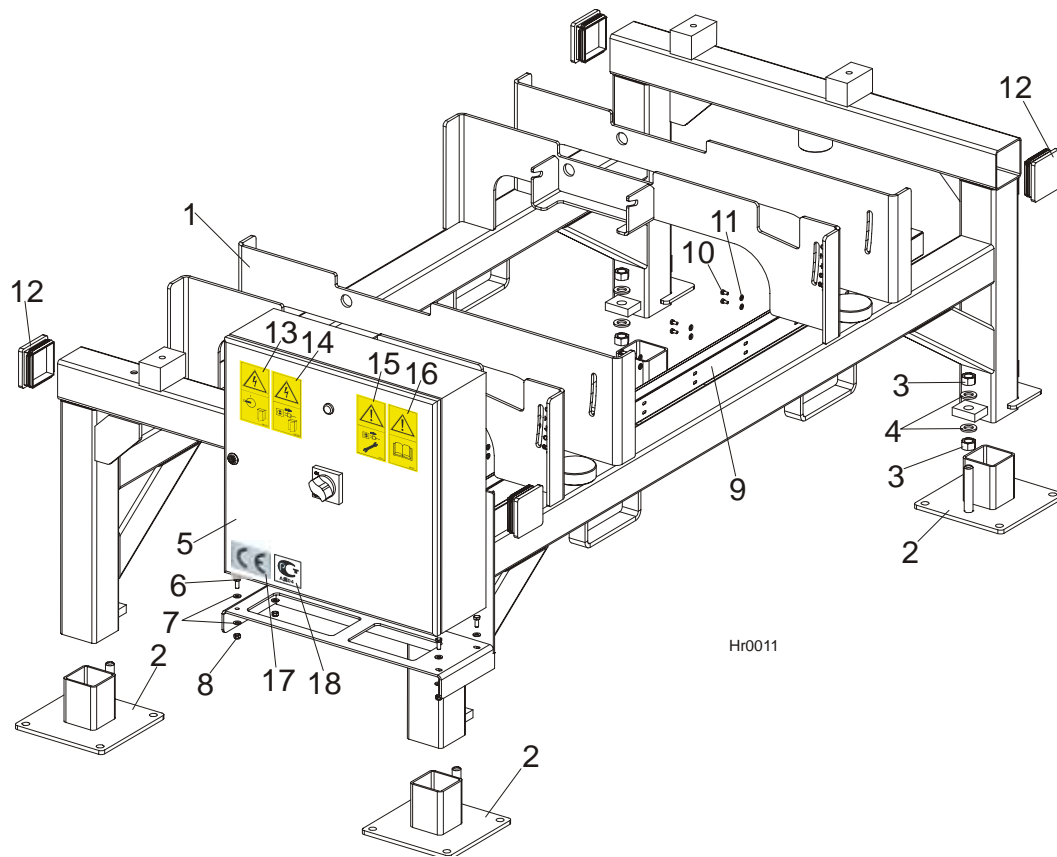

REF	DESCRIPTION (◆ Indicates Parts Available In Assemblies Only)	PART #	QTY.
	COMPLETE HR MAIN BASE FRAME	099023	1
1	FRAME, HR MAIN BASE	099024-1	1
2	FOOT, LEG ADJUSTABLE	099547-1	4
3	NUT, M20-8 HEX ZINC	F81037-1	8
4	WASHER, 21 FLAT ZINC	F81059-2	8
5	BOX, HR ELECTRIC	098683-M1	1
6	BOLT, M8x20-8.8-B HEX HEAD FULL THREAD ZINC	F81002-4	4
7	WASHER, 8.4 FLAT ZINC	F81054-1	8
8	NUT, M8-8-B HEX NYLON ZINC LOCK	F81032-2	4
9	DUCT, LH60x40x2000HD CABLE	099374	1
10	BOLT, M6x12-8.8 HEX HEAD FULL THREAD ZINC	F81001-7	20
11	WASHER, 6.4 FLAT ZINC	F81053-1	20
12	CAP, 100x100 SQUARE	090694	4
13	DECAL, HAZARDOUS VOLTAGE INSIDE THE ELECTRIC BOX (PICTOGRAM)	096316	1
14	DECAL, REMOVE THE PLUG BEFORE OPENING THE ELECTRIC BOX (PICTOGRAM)	096319	1
15	DECAL, DISCONNECT POWER SUPPLY BEFORE SERVICING (PICTOGRAM)	098177	1
16	DECAL, READ THE OPERATOR'S MANUAL (PICTOGRAM)	096317	1
17	DECAL, CE , CERTIFIED MACHINE (SMALL)	P85070	1
18	DECAL, GOST CERTIFIED MACHINE	099401	1

6.21 Main Module Feed Track

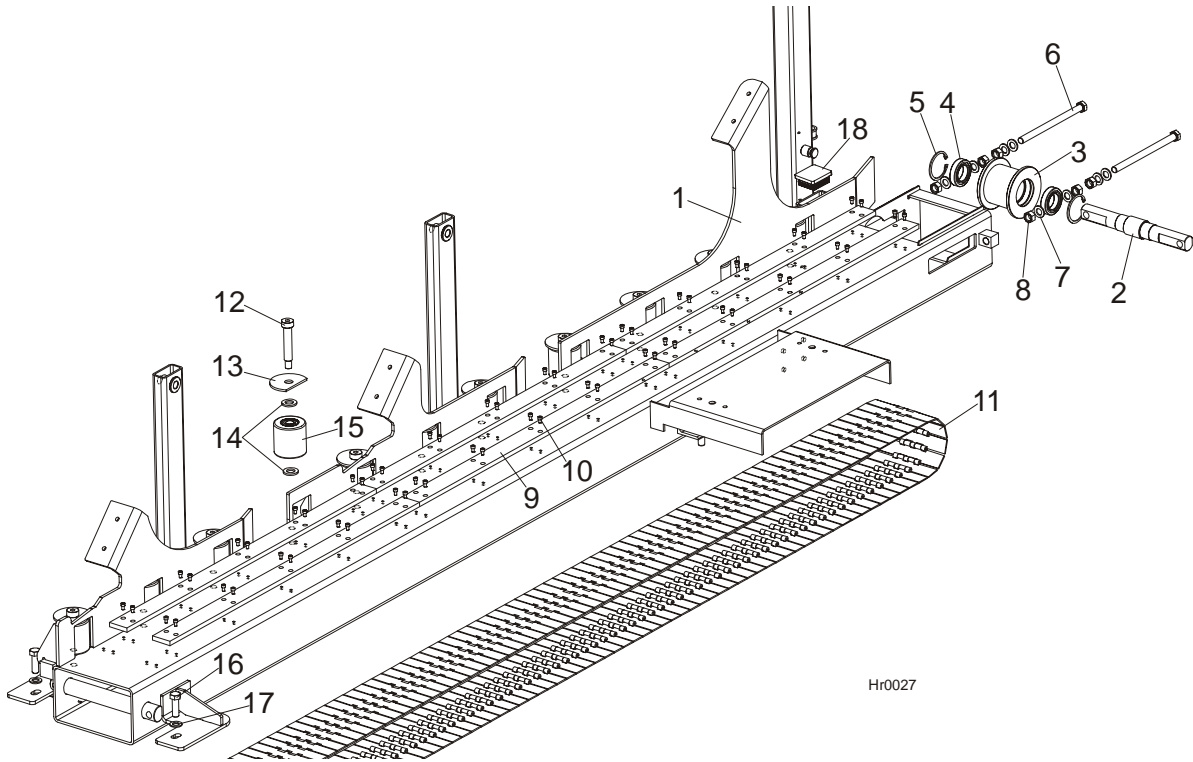

REF	DESCRIPTION (◆ Indicates Parts Available In Assemblies Only)	PART #	QTY.
	MAIN MODULE FEED TRACK - COMPLETE	099039	1
1	TRACK, HR2 MAIN MODULE FEED	099040-1	1
	PULLEY, CHAIN TENSION - COMPLETE	099340	1
2	AXLE, CHAIN TENSION PULLEY ZINC-PLATED	099337-1	1
3	PULLEY, CHAIN TENSION ZINC-PLATED	099336-1	1
4	BEARING, 6008 2RS FLT	086259	2
5	RING, W68 INSIDE RETAINING	F81090-16	2
6	BOLT, M16X240-8.8-A2 FULL THREAD	F81006-29	2
7	WASHER, 17 FLAT ZINC	F81058-1	8
8	NUT, M16-5.8 HEX ZINC	F81036-1	6
9	PAD, RESAW FEED TRACK	092080	6
10	SCREW, M6x10 -8.8 HEX SOCKET HEAD CAP ZINC	F81001-12	60
11	CHAIN, ACCATE S802K750 - 203 LINKS	099080	1
	CHAIN, ACCATE S802K750 - 114 LINKS	099344 ¹	1/2
12	BOLT, 20/M16X90 12.9 ISO7379 SHOULDER	F81006-30	11
13	COVER, SIDE ROLLER ZINC-PLATED	099441-1	11
14	WASHER, 21 FLAT ZINC	F81059-2	22
15	ROLLER, R-80-80 (ZABI) SIDE	099429	11
16	BOLT, M16x50-8.8 HEX HEAD FULL THREAD ZINC	F81006-7	4
17	WASHER, 17 FLAT ZINC	F81058-1	4
18	CAP, HR FRAME	089644	1

¹ Used only on HR3/4 (1 pcs) and on HR5/6 (2 pcs) as the 099080 chain extension.

6.22 Additional Module Base Frame

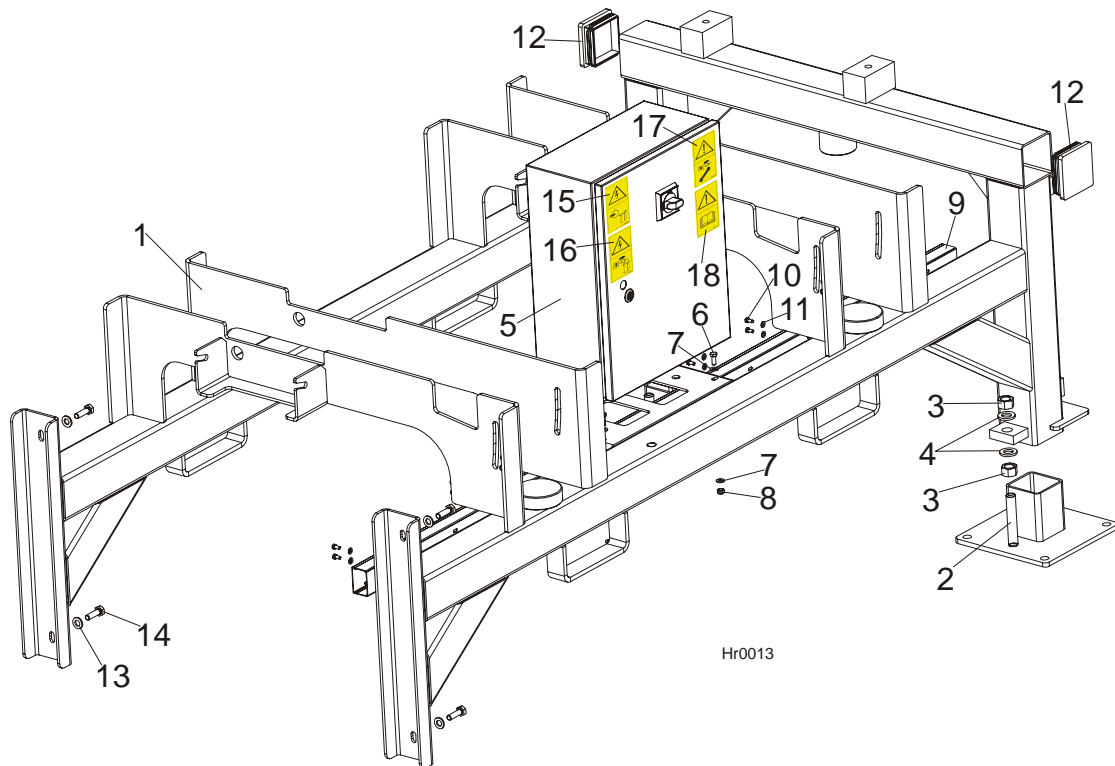

REF	DESCRIPTION (◆ Indicates Parts Available in Assemblies Only)	PART #	QTY.
	COMPLETE ADDITIONAL MODULE BASE FRAME	099031 ¹	1/2
1	FRAME, ADDITIONAL MODULE BASE	099032-1	1
2	FOOT, LEG ADJUSTABLE	099547-1	2
3	NUT, M20-8 HEX ZINC	F81037-1	4
4	WASHER, 21 FLAT ZINC	F81059-2	4
5	BOX, HR ELECTRIC	098683-M2	1
6	BOLT, M8x20-8.8-B HEX HEAD FULL THREAD ZINC	F81002-4	4
7	WASHER, 8.4 FLAT ZINC	F81054-1	8
8	NUT, M8-8-B HEX NYLON ZINC LOCK	F81032-2	4
9	DUCT, LH60x40x2000HD CABLE	099374	1
10	BOLT, M6x12-8.8 HEX HEAD FULL THREAD ZINC	F81001-7	16
11	WASHER, 6.4 FLAT ZINC	F81053-1	16
12	CAP, 100x100 SQUARE	090694	2
13	WASHER, 13 FLAT ZINC	F81056-1	4
14	BOLT, M12x40-8.8 HEX HEAD FULL THREAD ZINC	F81004-4	4
15	DECAL, HAZARDOUS VOLTAGE INSIDE THE ELECTRIC BOX (PICTOGRAM)	096316	1
16	DECAL, REMOVE THE PLUG BEFORE OPENING THE ELECTRIC BOX (PICTOGRAM)	096319	1
17	DECAL, DISCONNECT POWER SUPPLY BEFORE SERVICING (PICTOGRAM)	098177	1
18	DECAL, READ THE OPERATOR'S MANUAL (PICTOGRAM)	096317	1

¹ Used on HR3/4 - 1 pcs and on HR5/6 - 2 pcs.

6.23 Additional Module Feed Track

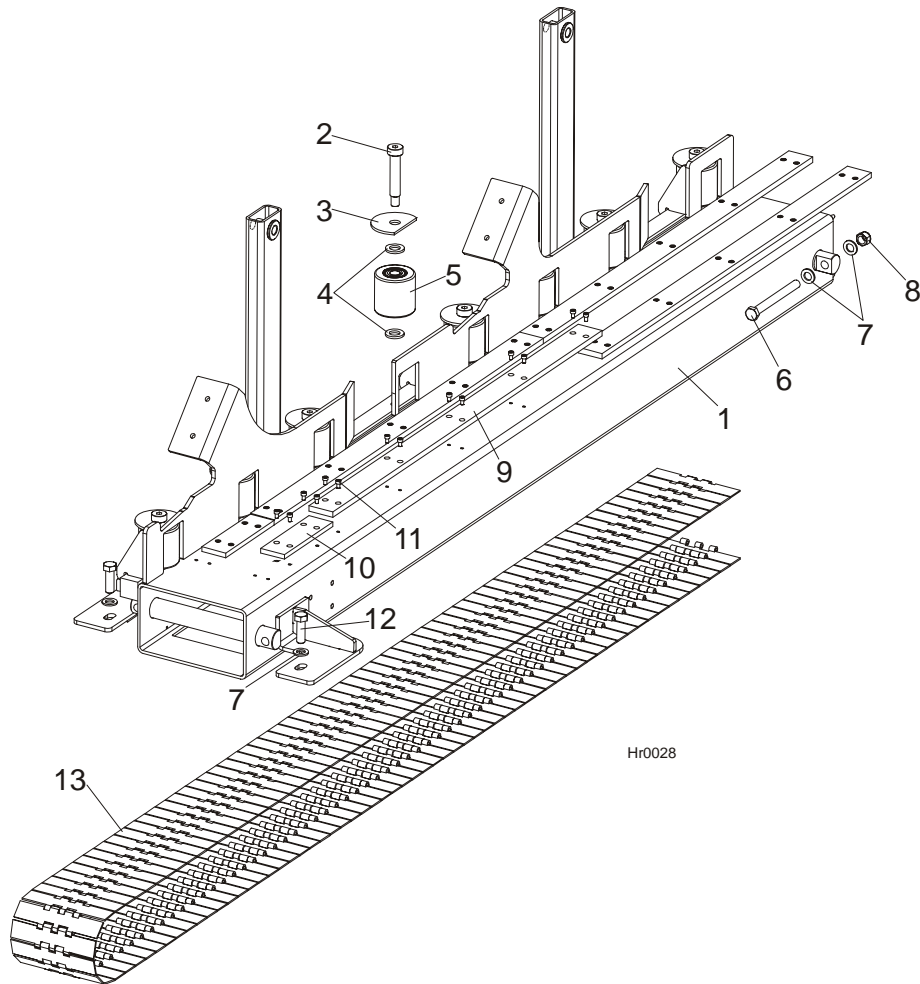

REF	DESCRIPTION (◆ Indicates Parts Available in Assemblies Only)	PART #	QTY.	
	ADDITIONAL MODULE FEED TRACK - COMPLETE	099440	1	
1	TRACK, HR2 FEED	099372-1	1	
2	BOLT, 20/M16X90 12.9 ISO7379 SHOULDER	F81006-30	8	
3	COVER, SIDE ROLLER ZINC-PLATED	099441-1	8	
4	WASHER, 21 FLAT ZINC	F81059-2	16	
5	ROLLER, R-80-80 (ZABI) SIDE	099429	8	
6	BOLT, M16x160-8.8 HEX HEAD ZINC	F81006-20	2	
7	WASHER, 17 FLAT ZINC	F81058-1	6	
8	NUT, M16-8 HEX NYLON ZINC LOCK	F81036-2	2	
9	PAD, RESAW FEED TRACK	092080	6	
10	PAD, FEED TRACK SHORT	099430	2	
11	SCREW, M6x10 -8.8 HEX SOCKET HEAD CAP ZINC	F81001-12	48	
12	BOLT, M16x50-8.8 HEX HEAD FULL THREAD ZINC	F81006-7	2	
13	CHAIN, ACCATE - 114 LINKS	099344	1	

6.24 Idle Roller Table, SLPIRT

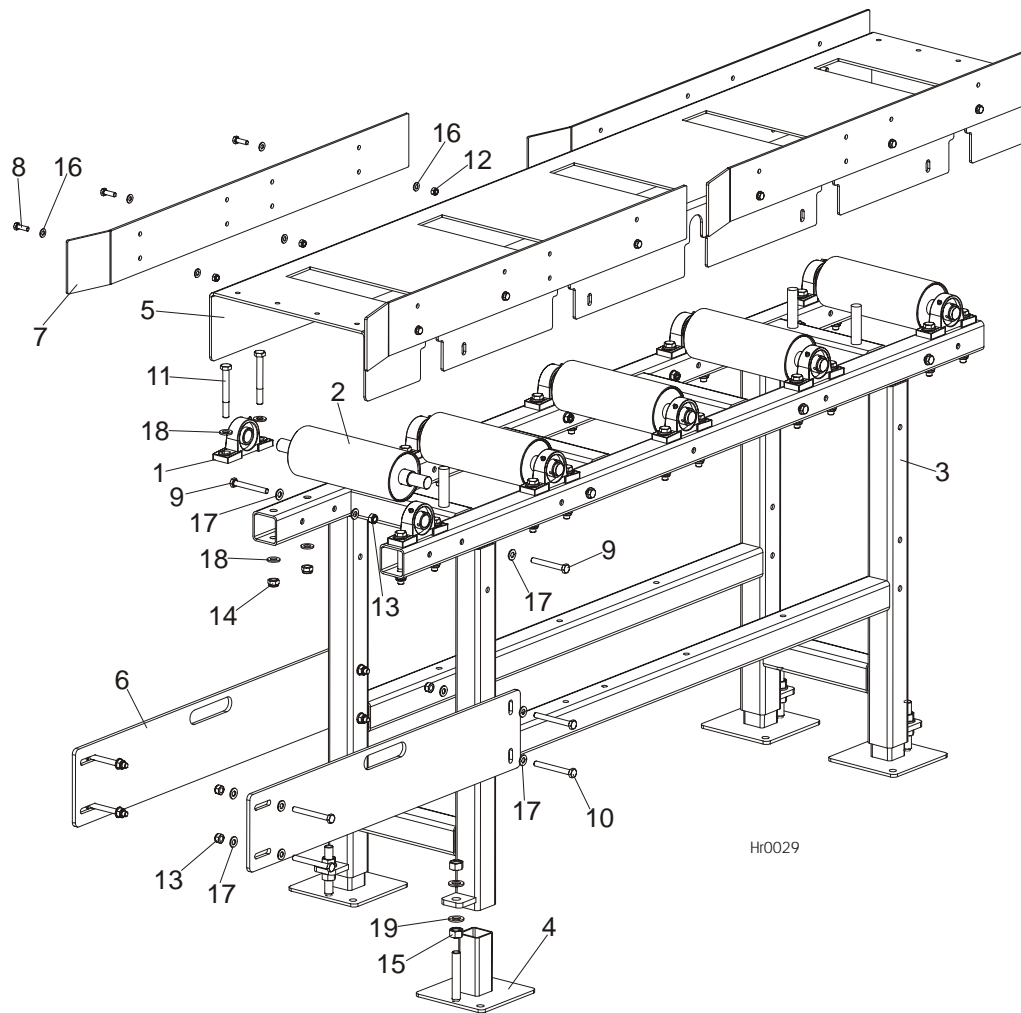

REF	DESCRIPTION (◆ Indicates Parts Available in Assemblies Only)	PART #	QTY.
	IDLE ROLLER TABLE, HR	SLPIRT	1
	COMPLETE MANUAL RETURN TABLE	099659	1
1	BEARING, UCP 205 CX W/HOUSING	088468	10
2	PLATE, SVS SAW HEAD MOUNTING	099140-1	5
3	FRAME, SVS INFEED & OUTFEED TABLE	099168-1	1
4	FOOT ASSEMBLY, TABLE LEG	099281-1	4
5	PLATE, RETURN TABLE TOP	099686-1	1
6	PLATE, RETURN TABLES CONNECTION	099687-1	2
7	PLATE, TABLE TOP FENCE	099688-1	4
8	BOLT, M8x25-8.8-B HEX HEAD FULL THREAD ZINC	F81002-5	12
9	BOLT, M10x80 -8.8 HEX HEAD ZINC	F81003-50	9
10	BOLT, M10x90 -8.8-B HEX HEAD ZINC	F81003-66	8
11	BOLT, M12x100-8.8 HEX HEAD ZINC	F81004-3	20

REPLACEMENT PARTS*Idle Roller Table, SLPIRT***6**

12	NUT, M8-8-B HEX NYLON ZINC LOCK	F81032-2	12	
13	NUT, M10-8-B HEX NYLON ZINC LOCK	F81033-1	17	
14	NUT, M12-8 HEX NYLON ZINC LOCK	F81034-2	20	
15	NUT, M16-5.8 HEX ZINC	F81036-1	8	
16	WASHER, 8.4 FLAT ZINC	F81054-1	23	
17	WASHER, 10.5 FLAT ZINC	F81055-1	34	
18	WASHER, 13 FLAT ZINC	F81056-1	40	
19	WASHER, 17 FLAT ZINC	F81058-1	8	

6.25 Cross Roller Table, SLPCRT

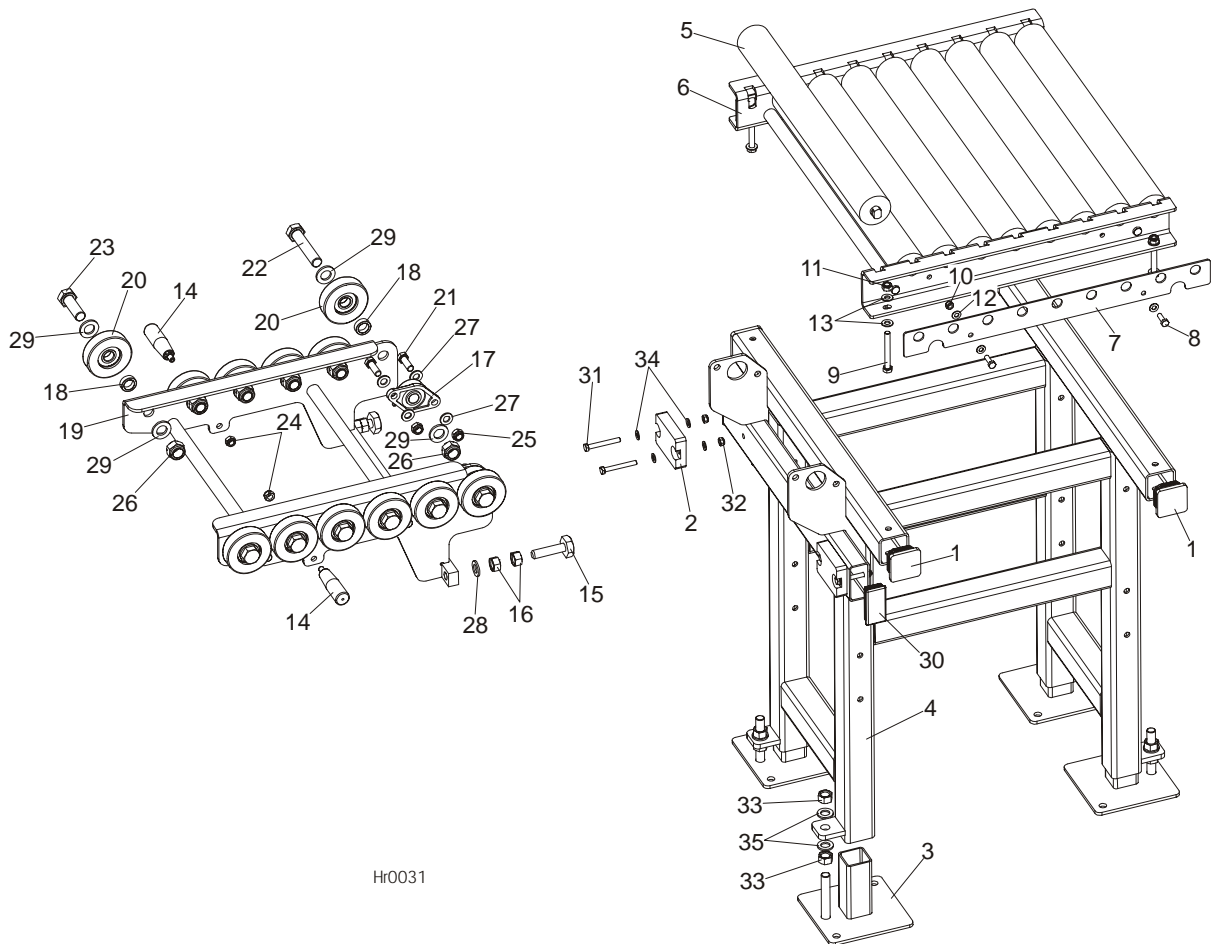

Hr0031

REF	DESCRIPTION (◆ Indicates Parts Available In Assemblies Only)	PART #	QTY.
	CROSS ROLLER TABLE, HR	SLPCRT	1
	COMPLETE CROSS RETURN TABLE	099648	1
1	CAP, 1540 DIA. OUTRIGGER LEG	089710	4
2	BUMPER, GRENE 70 3201 0010. SHR RUBBER	094969	2
3	FOOT ASSEMBLY, TABLE LEG	099281-1	4
4	FRAME WELDMENT, CROSS RETURN TABLE	099652-1	1
	TOP, 63.5X600 CROSS RETURN TABLE - COMPLETE	099656	1
5	ROLLER, 63.5/20X600/608/626 s=14 (EE15) PTD	089044-1	9
6	BRACKET, 63.5X600 ROLLER MOUNTING	099649-1	1
7	PLATE, 63.5/20X600 ROLLER CLAMP	099650-1	2
8	BOLT, M8x25-8.8-B HEX HEAD FULL THREAD ZINC	F81002-5	4
9	BOLT, M10x80 -8.8 HEX HEAD ZINC	F81003-50	4
10	NUT, M8-8-B HEX NYLON ZINC LOCK	F81032-2	4
11	NUT, M10-8-B HEX NYLON ZINC LOCK	F81033-1	4
12	WASHER, 8.4 FLAT ZINC	F81054-1	8

REPLACEMENT PARTS

Cross Roller Table, SLPCRT

6

13	WASHER, 10.5 FLAT ZINC	F81055-1	8	
	TABLE, RP-90 OPENED W/ROLLERS - COMPLETE	099679	1	
14	KNOB, PLASTIC CRANK HANDLE	086338	2	
	M16 BOLTS +2 NUTS	093710	2	
15	NUT, M16-5-B HEX	F81036-5	1	
16	BOLT, M16 BED RAIL ADJUSTMENT	086809	2	
17	BEARING, UCFL204 (COMPLEX) W/HOUSING	099078	2	
18	BUSHING, 21X30X10 ZINC-PLATED SPACER	099351-1	12	
19	FRAME, OPENED TABLE	099680-1	1	
20	ROLLER, RP-90. 6304 POLYURETHANE	099689	12	
21	BOLT, M12x35-8.8 HEX HEAD FULL THREAD ZINC	F81004-24	4	
22	BOLT, M20X100-8.8 HEX HEAD ZINC	F81007-6	2	
23	BOLT, M20X60-8.8 HEX HEAD ZINC	F81007-7	10	
24	NUT, M10-8-B HEX NYLON ZINC LOCK	F81033-1	2	
25	NUT, M12-8 HEX NYLON ZINC LOCK	F81034-2	4	
26	NUT, M20-8-A HEX NYLON ZINC LOCK	F81037-2	12	
27	WASHER, 13 FLAT ZINC	F81056-1	8	
28	WASHER, 17 FLAT ZINC	F81058-1	2	
29	WASHER, 21 FLAT ZINC	F81059-2	24	
30	CAP, 80x40 TUBE END	099692	2	
31	BOLT, M8x65 8.8 HEX HEAD FULL THREAD ZINC	F81002-9	4	
32	NUT, M8-8-B HEX NYLON ZINC LOCK	F81032-2	4	
33	NUT, M16-5.8 HEX ZINC	F81036-1	8	
34	WASHER, 8.4 FLAT ZINC	F81054-1	8	
35	WASHER, 17 FLAT ZINC	F81058-1	8	

6.26 Additional Control Box Support Tube

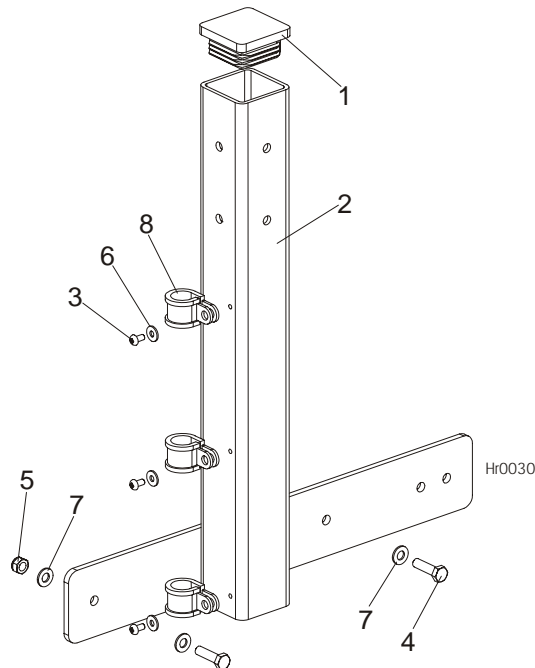

REF	DESCRIPTION (◆ Indicates Parts Available In Assemblies Only)	PART #	QTY.	
	COMPLETE ADDITIONAL CONTROL BOX SUPPORT	100048	1	
1	CAP, 1540 DIA. OUTRIGGER LEG	089710	1	
2	TUBE, ADDITIONAL CONTROL BOX SUPPORT	100045-1	1	
3	SCREW, H M5x10 8.8 CROSS RECESSED PAN HEAD ZINC	F81000-13	3	
4	BOLT, M8x30-8.8-B HEX HEAD FULL THREAD ZINC	F81002-7	2	
5	NUT, M8-8-B HEX NYLON ZINC LOCK	F81032-2	2	
6	WASHER, 5.5 SPECIAL FLAT ZINC	F81052-3	3	
7	WASHER, 8.4 FLAT ZINC	F81054-1	4	
8	CLAMP, RSGU 1.20/20 W1	F81087-2	3	

SECTION 7 DC ELECTROMAGNETIC BRAKE

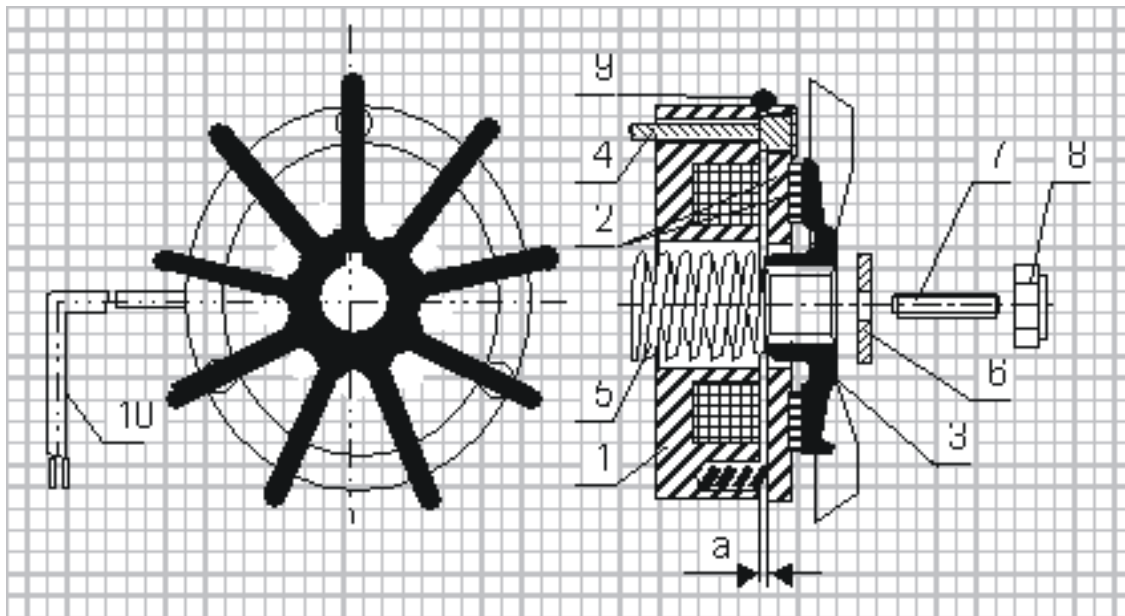

- 1 - Electromagnet,
- 2 - Armature complete with brake linings,
- 3 - Fan,
- 4 - Retaining bolt
- 5 - Central spring,
- 6 - Special washer,
- 7 - Set screw,
- 8 - Self-locking nut,
- 9 - Sealing ring,
- 10 - Output cable.

7.1 Design and principle of operation

The DC electromagnetic brake type H consists of 3 main subassemblies:

- electromagnet (1),
- armature complete (2)
- cast iron fan (3).

Electromagnet (1) energised: The DC voltage from the motor applied via the rectifying circuit causes the attraction of the armature (2) releasing the brake and thus the fan (3) is free to rotate.

Electromagnet (1) de-energised: The electromagnet stops to attract the armature (2) and spring presses the armature with brake linings (2) against the fan and the brake is thus applied.

7.2 Service

During normal operation and at the routine inspections verify the air gap and check if all screws are tight. In case when any symptoms of inefficient braking are observed, then use the self-locking nut (8) to re-adjust the air gap to the value corresponding to Table 1.

Such readjustment may be repeated until the brake linings are completely worn out. When this will occur, a complete armature with brake linings (2) must be replaced.

If the air gap of the brake is correctly adjusted and despite of it the brake does not operate properly (the brake fails to release), it may be caused by:

- the electromagnet (1): burned coil or defected output cable (10),
- rectifying circuit (installed in the electric motor terminal box).

The above mentioned subassemblies should be checked and defected part replaced.

Table 1:

TYPE	H-63	H-71	H-80	H-90	H-100	H-112	H-132	H-160
Nominal Gap „a”	0.2 ±0,05	0.2 ±0,05	0.2 ±0,05	0.2 ±0,05	0.2 ±0,1	0.2 ±0,1	0.2 ±0,1	0.2 ±0,1