

**Wood-Mizer®**  
**Twin Vertical Saw Flat Tables**  
**TVS - FT**  
**Parts Manual**

---

**TVSE11S - FT**  
**TVSE15S - FT**

**rev.A4.00**  
**rev.A4.00**

---



**Safety is our #1 concern!** Read and understand all safety information and instructions before operating, setting up or maintaining this machine.

*August 2007*

*Form #1005*

# Table of Contents

# Section-Page

<b>SECTION 1</b>	<b>GENERAL INFORMATION</b>	<b>1-1</b>
1.1	How To Use The Parts List .....	1-1
1.2	Sample Assembly .....	1-1
<b>SECTION 2</b>	<b>BLADE GUIDE ROLLERS &amp; ARM</b>	<b>2-1</b>
2.1	Blade Guide Assembly, Idle Side.....	2-1
2.2	Blade Guide Assembly, Drive Side.....	2-3
<b>SECTION 3</b>	<b>BLADE WHEELS &amp; TENSIONER</b>	<b>3-1</b>
3.1	Blade Wheel Assembly, Drive Side .....	3-1
3.2	Blade Wheel Assembly, Idle Side .....	3-2
3.3	Blade Tensioner Assembly.....	3-3
3.4	Blade Tensioner Pump Assembly .....	3-5
<b>SECTION 4</b>	<b>SAW HEAD</b>	<b>4-1</b>
4.1	Middle Throat Screw .....	4-1
4.2	Water Lube Assembly (LMS) .....	4-2
4.3	Saw Head Decals.....	4-4
4.4	Blade Housing Cover .....	4-5
4.5	Saw Head Width Manual Adjustment Assembly .....	4-7
4.6	Saw Head Width Automatic Adjustment Assembly (Optional).....	4-9
4.7	Saw Head Width Indicator .....	4-12
4.8	Saw Head Slide Brackets.....	4-13
4.9	Hold-Down Roller .....	4-14
4.10	Blade Drive Motor.....	4-16
4.11	Saw Head Support Rollers.....	4-18
4.12	Electric Box .....	4-20
4.13	Control Box .....	4-21
4.14	Laser Assembly (Optional).....	4-23
<b>SECTION 5</b>	<b>INFEED &amp; OUTFEED FLAT TABLES</b>	<b>5-1</b>
5.1	TVS FT Infeed Table.....	5-1
5.2	TVS FT Outfeed Table .....	5-3
5.3	Roller Infeed & Outfeed Table.....	5-4
5.4	Hold-Down Roller Kit.....	5-5
<b>SECTION 6</b>	<b>INCLINE LOG DECK</b>	<b>6-1</b>
6.1	Infeed Assembly .....	6-1
6.2	Additional Grid, Option For TVS Incline Log Deck .....	6-2
6.3	Limit Switch Assembly .....	6-3
6.4	Drive Assembly .....	6-4
6.5	Chain Guards .....	6-6
6.6	Decals .....	6-7

# Table of Contents

# Section-Page

<b>SECTION 7</b>	<b>CROSS TRANSFER DECK</b>	<b>7-1</b>
7.1	Front Module & Chains.....	7-1
7.2	Central Module.....	7-2
7.3	Rear Module .....	7-3
7.4	Cross Transfer Deck Drive.....	7-4
7.5	Leg Kits .....	7-5
7.6	Slabs Table .....	7-6
7.7	Decals .....	7-7

## SECTION 1 GENERAL INFORMATION

### 1.1 How To Use The Parts List

- Use the index above to locate the assembly that contains the part you need.
- Go to the appropriate section and locate the part in the illustration.
- Use the number pointing to the part to locate the correct part number and description in the table.
- Parts shown indented under another part are included with that part.
- Parts marked with a diamond (◆) are only available in the assembly listed above the part.

See the sample table below. Sample Part #A01111 includes part F02222-2 and subassembly A03333. Subassembly A03333 includes part S04444-4 and subassembly K05555. The diamond (◆) indicates that S04444-4 is not available except in subassembly A03333. Subassembly K05555 includes parts M06666 and F07777-77. The diamond (◆) indicates M06666 is not available except in subassembly K05555.

<b>1.2 Sample Assembly</b>				
REF	DESCRIPTION (◆ Indicates Parts Available In Assemblies Only)	PART #	QTY.	
	Sample Assembly, Complete (Includes All Indented Parts Below)	A01111	1	
1	Sample Part	F02222-22	1	
	Sample Subassembly (Includes All Indented Parts Below)	A03333	1	
2	Sample Part (◆ Indicates Part Is Only Available With A03333)	S04444-4	1	◆
	Sample Subassembly (Includes All Indented Parts Below)	K05555	1	
3	Sample Part (◆ Indicates Part Is Only Available With K05555)	M06666	2	◆
4	Sample Part	F07777-77	1	

#### To Order Parts:

- From Europe call our European Headquarters and Manufacturing Facility in Kolo, Poland at **+48-63-2626000**. From the continental U.S., call our toll-free Parts hotline at **1-800-525-8100**. Have your customer number, vehicle identification number, and part numbers ready when you call. From other international locations, contact the Wood-Mizer distributor in your area for parts.

#### Office Hours:

Country	Monday - Friday	Saturday	Sunday
Poland	7-15	Closed	Closed
US	8 a.m.- 5 p.m.	Closed	Closed



**CAUTION!** It is strongly recommended that only original spare parts be used.

## SECTION 2 BLADE GUIDE ROLLERS & ARM

### 2.1 Blade Guide Assembly, Idle Side

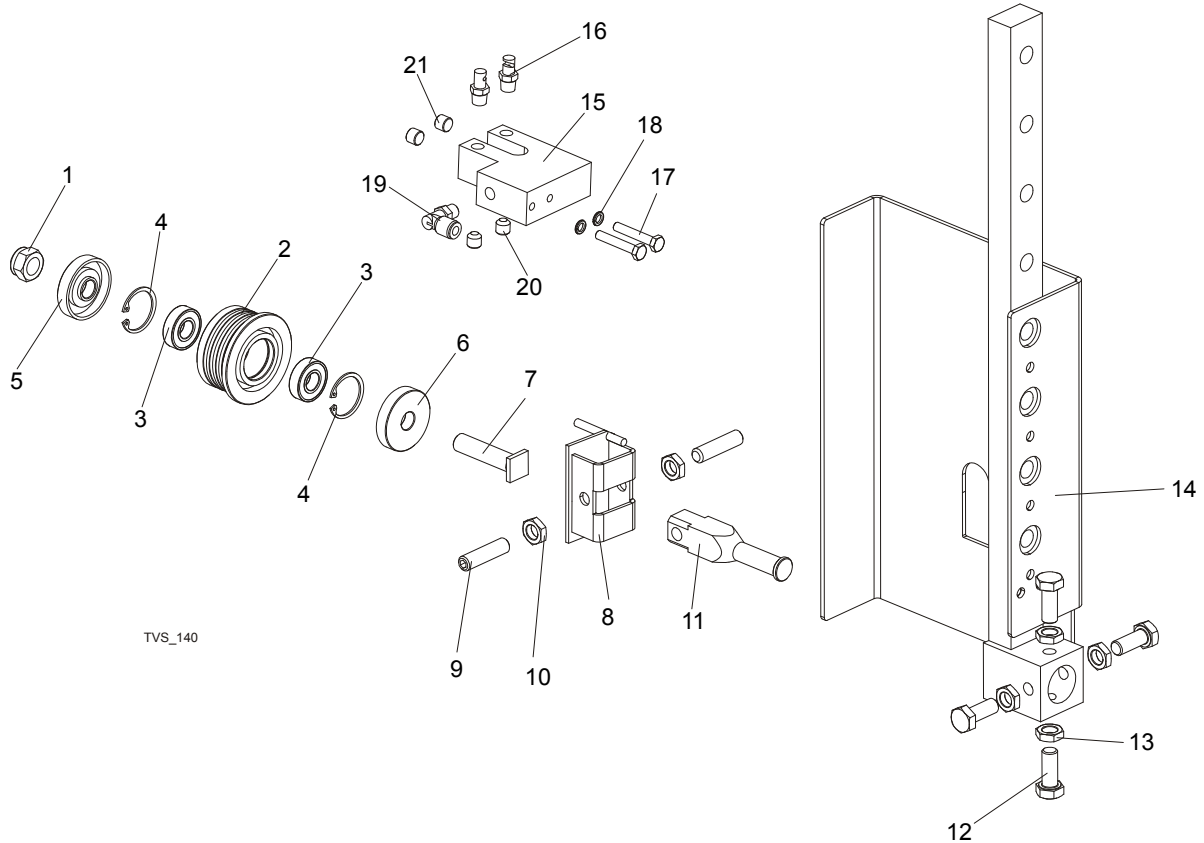

REF	DESCRIPTION (◆ Indicates Parts Available In Assemblies Only)	PART #	QTY.
	<b>ROLLER, TVS BLADE GUIDE COMPLETE</b>	500562	1
	ROLLER, TVS BLADE GUIDE	500561	1
1	NUT, M12-8 HEX NYLON ZINC LOCK	F81034-2	1
2	ROLLER, TVS BLADE GUIDE WIDE	500560	1
3	BEARING, 6001 2RSR FAG	087893	2
4	RING, W28 INSIDE RETAINING	F81090-9	1
5	RING, ZINC-PLATED SPACER (FOR EXTEND.ROLL)	087891-1	1
6	RING, ZINC-PLATED SPACER (FOR EXTEND.ROLL)	087892-1	1
7	SHAFT, BLADE GUIDE ROLLER ZINC-PLATED	087762-1	1
8	BRACKET WELDMENT, BLADE GUIDE PAINTED	500563-1	1
9	SCREW, M10X1X40 DIN 913 A2-70 SET STAINLESS STEEL	F81015-2	2
10	NUT, M10X1-04-ST-A2 ISO 8675 THIN	F81033-10	2
11	SHAFT, BLADE GUIDE MOUNT ZINC-PLATED	088255-1	1
12	<b>BOLT, M10x1x25 DIN 933</b>	F81003-28	4
13	<b>NUT, M10x1-04-ST-A2 ISO 8675 THIN</b>	F81033-10	4

14	ROLLER GUIDE, TVS RIGHT-PTD	096131-1	1	
	ROLLER GUIDE, TVS LEFT- PTD	098608-1	1	
	LUBE SYSTEM, TVS	098583	2	
15	BLOCK, NOZZLE MOUNTING ZINC-PLATED	097943-1	1	
16	NOZZLE, BLADE LUBE SPRAY	033479	2	
17	BOLT, M6x35 8.8 HEX HEAD ZINC	F81001-71	2	
18	WASHER, M6 SPLIT LOCK ZINC	F81053-3	2	
19	Fitting, 1/8MPTx1/4Tube,Elbow,Swivel	P09736	1	
20	Fitting, 1/8 NPT Socket Pipe Plug	P30127	2	
21	PLUG, M10x1 DIN 906 BN40 "BOSSARD"	F81015-3	2	

## 2.2 Blade Guide Assembly, Drive Side

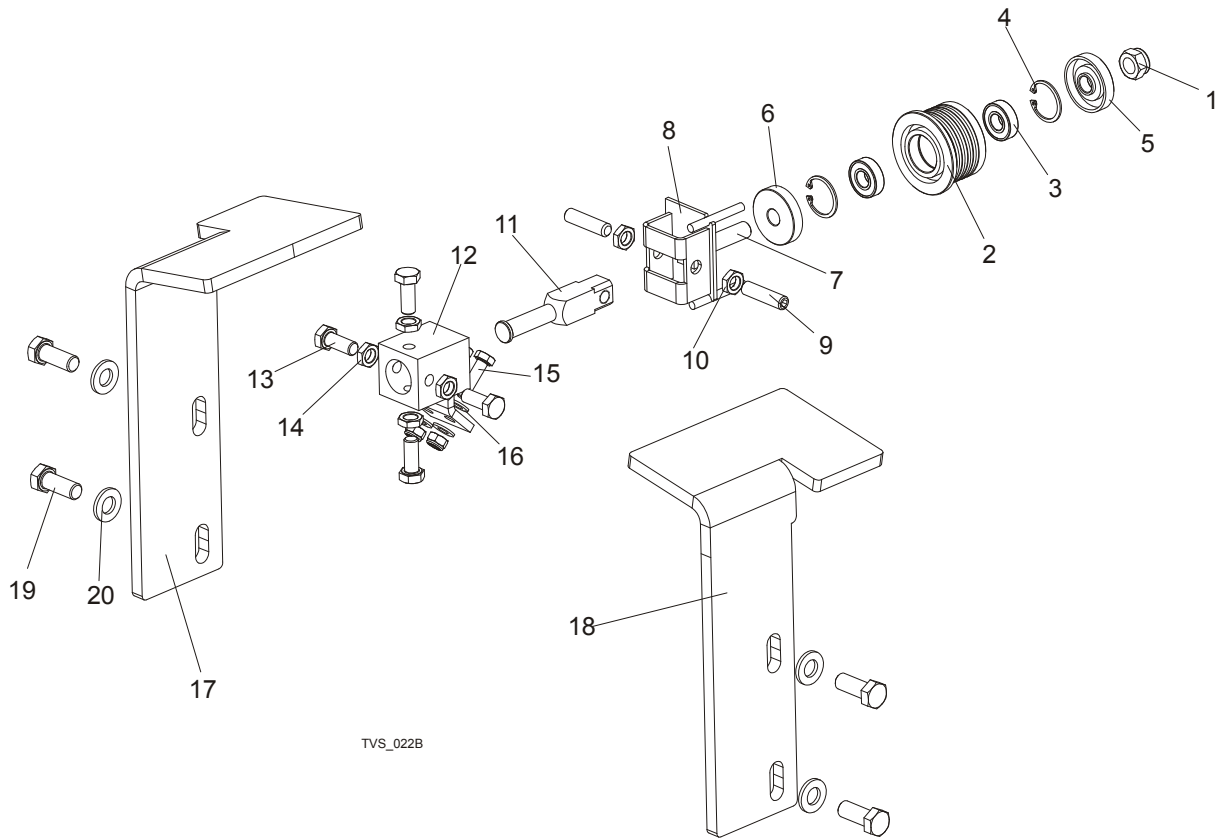

TVS\_022B

REF	DESCRIPTION (◆ Indicates Parts Available In Assemblies Only)	PART #	QTY.	
	<b>ROLLER, TVS BLADE GUIDE COMPLETE</b>	500562	1	
	ROLLER, TVS BLADE GUIDE	500561	1	
1	NUT, M12-8 HEX NYLON ZINC LOCK	F81034-2	1	
2	ROLLER, TVS BLADE GUIDE WIDE	500560	1	◆
3	BEARING, 6001 2RSR FAG	087893	2	
4	RING, W28 INSIDE RETAINING	F81090-9	1	
5	RING, ZINC-PLATED SPACER (FOR EXTEND.ROLL)	087891-1	1	
6	RING, ZINC-PLATED SPACER (FOR EXTEND.ROLL)	087892-1	1	
7	SHAFT, BLADE GUIDE ROLLER ZINC-PLATED	087762-1	1	
8	BRACKET WELDMENT, BLADE GUIDE PAINTED	500563-1	1	
9	SCREW, M10X1X40 DIN 913 A2-70 SET STAINLESS STEEL	F81015-2	2	
10	NUT, M10X1-04-ST-A2 ISO 8675 THIN	F81033-10	2	
11	SHAFT, BLADE GUIDE MOUNT ZINC-PLATED	088255-1	1	
12	<b>BLOCK WELDMENT, PAINTED BLADE GUIDE MOUNT</b>	088292-1	3	
13	<b>BOLT, M10X1X25 DIN 933 STAINLESS STEEL</b>	F81003-28	1	
14	<b>NUT, M10x1-04-ST-A2 ISO 8675 THIN</b>	F81033-10	4	
15	<b>BOLT, M8X20MM, HEX HEAD,GR 5.8 ZINC</b>	F81002-4	2	

**2****Blade Guide Rollers & Arm***Blade Guide Assembly, Drive Side*

---

16	WASHER, 8.2 SPLIT LOCK ZINC	F81054-4	2	
17	COVER, DRIVE SIDE ROLLER RIGHT	097660-1	1	
18	COVER, DRIVE SIDE ROLLER LEFT	098435-1	1	
19	BOLT M12x30-8.8	F81004-22	4	
20	WASHER, M12 , FLAT, ZINC	F81056-1	4	



## SECTION 3 BLADE WHEELS & TENSIONER

### 3.1 Blade Wheel Assembly, Drive Side

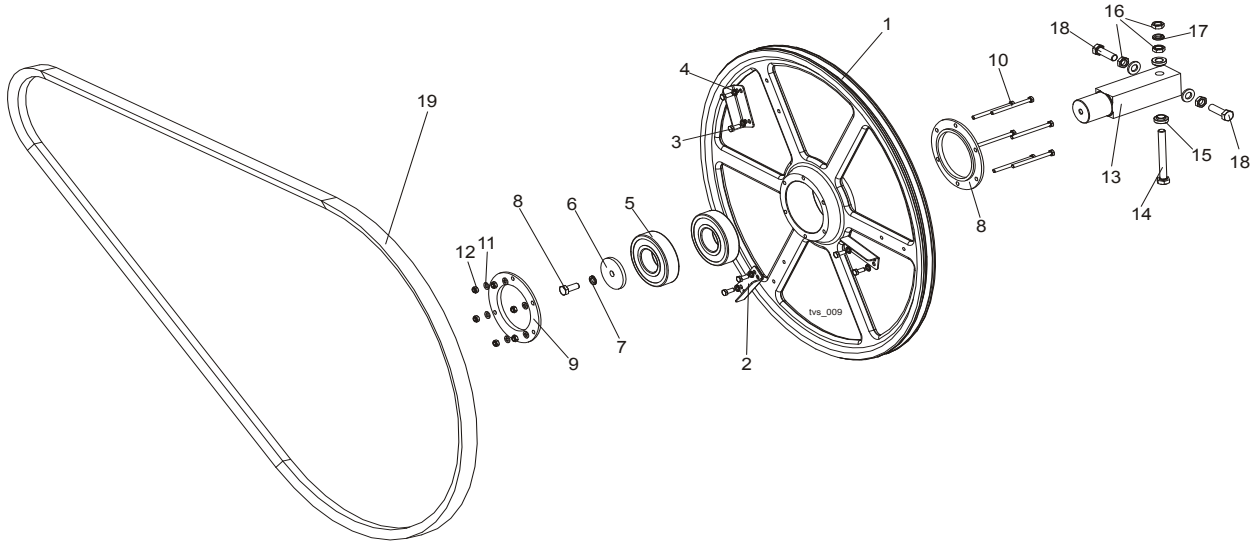

REF	DESCRIPTION (◆ Indicates Parts Available In Assemblies Only)	PART #	QTY.
	<b>DRIVE WHEEL, TVS, COMPLETE</b>	096109	1
1	Drive Blade Wheel	096105-1	1
2	Wing, TVS	097808-1	3
3	Bolt, M6 x 16 8.8 Hex Head Full Thread Zinc	F81001-15	6
4	Washer, Z6.1 Split Lock Zinc	F81053-3	6
5	Bearing 6309 2RSR	096107	2
6	Washer, Idle Blade Wheel Retaining	088957-1	1
7	Washer, 10.2 Split Lock Zinc	F81055-2	1
8	Bolt, M10X25 8.8 Hex Head Full Thread	F81003-31	1
9	Ring, Bearing Mounting	096108-1	2
10	Bolt, M6x80 Fe/Zn5	F81001-61	6
11	Washer, 6.4 Flat Zinc	F81053-1	6
12	Nut, M6-8-B Hex Nylon Zinc Lock	F81031-2	6
13	<b>AXLE, DRIVE WHEEL, TVS</b>	096110	1
14	<b>BOLT, M12X1.25X100-8.8 HEX HEAD ZINC</b>	F81004-41	1
15	<b>SPACER, BLADE GUIDE</b>	086769-1	2
16	<b>NUT, M12X1.25 8.8 HEX ZINC THIN</b>	F81034-5	3
17	<b>WASHER, M12 SPLIT LOCK ZINC</b>	F81056-2	1
18	<b>BOLT, M12X1.25X40 HEX HEAD</b>	F81004-42	2
19	<b>IDLE SIDE BELT 5VX1080</b>	033391	1



### 3.3 Blade Tensioner Assembly

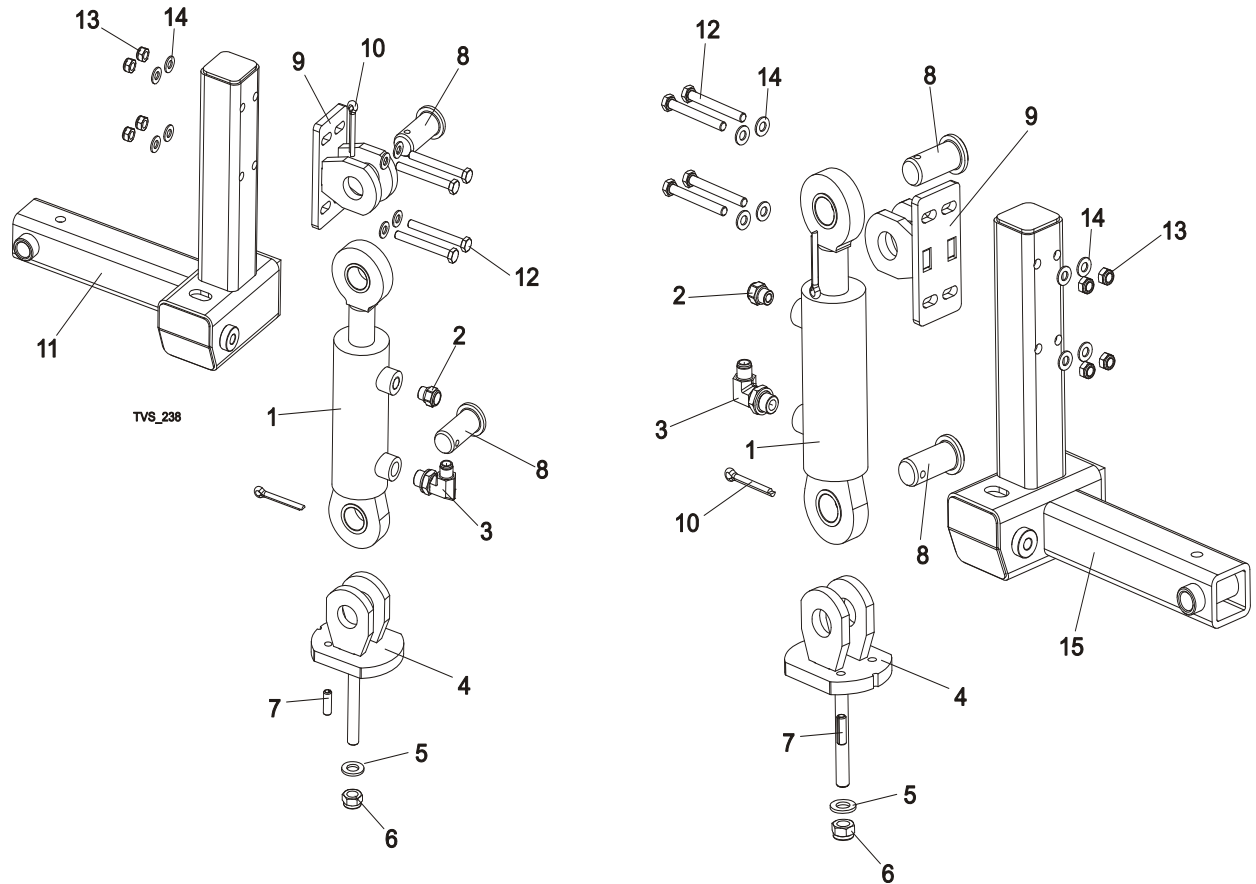

REF	DESCRIPTION (◆ Indicates Parts Available In Assemblies Only)	PART#	QTY.
	<b>HYDRAULIC BLADE TENSIONER, RIGHT SIDE</b>	504826	1
1	CYLINDER, SJ2F-16-50/28/70 HYDRAULIC	504812	1
2	BREATHER TYPE 2901-14-17	090794	1
3	FITTING 3/8" BSP-9/16" JIC ELBOW	096335	1
4	MOUNTING BRACKET, HYDRAULIC CYLINDER, LOWER	504822-1	1
5	WASHER, M12 FLAT ZINC	F81056-1	1
6	NUT, M12-8 ,HEX NYLON ZINC LOCK	F81034-2	1
7	PIN, 8X26 FE/ZN5 ROLL	F81046-4	1
8	PIN, ZINC-PLATED	504824-1	4
9	MOUNTING BRACKET, HYDRAULIC CYLINDER, UPPER	504819-1	2
10	PIN S-ZN 6,3X45 COTTER	F81045-2	4
11	ARM WELDMENT, TVS IDLE RIGHT SIDE BLADE WHEEL	504817-1	1
12	BOLT M8X70 8.8 FE/ZN5	F81002-71	8
13	NUT, M8-8-B HEX NYLON LOCK ZINC	F81032-2	8
14	WASHER, 8.4 FLAT ZINC	F81054-1	16
	<b>HYDRAULIC BLADE TENSIONER, LEFT SIDE</b>	504815	1
1	CYLINDER, SJ2F-16-50/28/70 HYDRAULIC	504812	1
2	BREATHER TYPE 2901-14-17	090794	1
3	FITTING, 3/8" BSP-9/16" JIC ELBOW	096335	1

4	MOUNTING BRACKET, HYDRAULIC CYLINDER, LOWER	504822-1	1	
5	WASHER, M12 FLAT ZINC	F81056-1	1	
6	NUT, M12-8 HEX NYLON ZINC LOCK	F81034-2	1	
7	PIN, 8X26 FE/ZN5 ROLL	F81046-4	1	
8	PIN, ZINC-PLATED	504824-1	4	
9	MOUNTING BRACKET, HYDRAULIC CYLINDER, UPPER	504819-1	2	
10	PIN S-ZN 6,3X45 COTTER	F81045-2	4	
11	USED IN 504826 ASSEMBLY			
12	BOLT, M8X70 8.8 HEX HEAD ZINC	F81002-71	8	
13	NUT, M8-8-B HEX NYLON LOCK ZINC	F81032-2	8	
14	WASHER, 8.4 FLAT ZINC	F81054-1	16	
15	ARM WELDMENT, TVS IDLE LEFT SIDE BLADE WHEEL	504816-1	1	

### 3.4 Blade Tensioner Pump Assembly

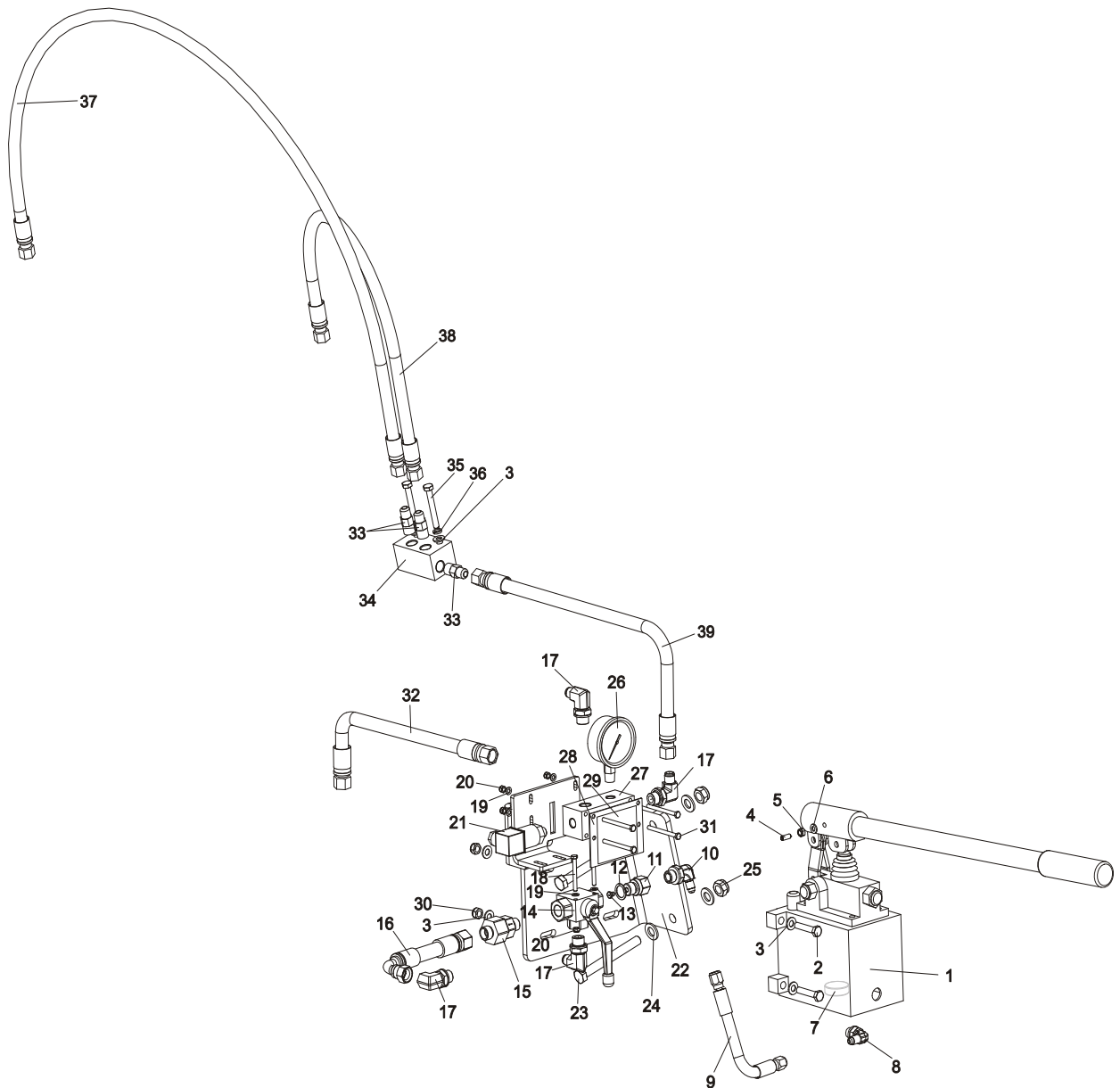

REF	DESCRIPTION (◆ Indicates Parts Available In Assemblies Only)	PART#	QTY.
	<b>BLADE TENSIONER PUMP ASSEMBLY</b>	504825	1
1	PUMP, PMS12/TNK1 MANUAL W/1-LITRE TANK	092789	1
2	BOLT, M8x40-8.8 HEX HEAD FULL THREAD ZINC	F81002-15	4
3	WASHER, 8.4 FLAT ZINC	F81054-1	10
4	PLUNGER, GN615.3-M6-K BALL THREADED	096874	1
5	NUT, M6-8-B HEX NYLON ZINC LOCK	F81031-2	1
6	WASHER, 6.4 FLAT ZINC	F81053-1	1
7	MAGNET, MW.38x12/N38 NEODYMIUM	500022	1
8	ELBOW, CA-204410-3	094562	1

9	HOSE, 1/4"(0.19M) HYDRAULIC	505174	1	
10	ELBOW, CA-204411-3	094563	1	
	FITTING W/NOZZLE, G 3/8	096849	1	
11	FITTING, G3/8 ZINC-PLATED SPECIAL	096850-1	1	
12	WASHER, 16 COPPER	F81058-3	1	
13	NOZZLE, D092-O 1MM DIA. PROPANE&BUTANE	091007	1	
14	VALVE, RSAP3 VOL2L G3/8" THREE-WAY	504803	1	
15	VALVE, RHV12LREDA3C CHECK	094559	1	
16	HOSE, 3/8" W/9/16 ;M18X1.5 END FITTING	504831	1	
17	FITTING, 3/8" BSP-9/16" JIC ELBOW	096335	4	
18	BOLT, M5X45 DIN933 A2-70 STAINLESS STEEL	F81000-22	2	
19	WASHER, 5.3 FLAT ZINC	F81052-1	6	
20	NUT, M5-8 DIN 985 ZINC-PLATED	F81030-2	6	
21	SWITCH, F4-T-I-M3-16 BAR PRESSURE	504830	1	
22	PLATE WELDMENT, PTD MOUNTING	504836-1	1	
23	BOLT, M12x110-8.8-B HEX HEAD ZINC	F81004-47	2	
24	WASHER, 13 FLAT ZINC	F81056-1	4	
25	NUT, M12-8 HEX NYLON ZINC LOCK	F81034-2	2	
26	GAUGE, 3000PSI OIL PRESSURE	505176	1	
27	BLOCK, ZINC-PLATED MOUNTING	504829-1	1	
28	PLATE - ZINC-PLATED	505310-1	1	
29	DECAL, TVS BLADE TENSIONER HANDLE POSITION	505346	1	
30	NUT, M8-8-B HEX NYLON LOCK ZINC	F81032-2	4	
31	BOLT, M5X60 8.8 HEX HEAD ZINC	F81000-36	4	
32	PHD 2T3/8X0.380 W9/16UNF-W9/16UNF	504706	1	
33	FITTING, G3/8-9/16-18JIC MANUAL PUMP	091842	3	
34	TEE FITTING - ZINC-PLATED	504828-1	1	
35	BOLT, M8X60-8.8 HEX HEAD ZINC	F81002-54	2	
36	WASHER, 8.2 SPLIT LOCK ZINC	F81054-4	2	
37	HOSE, 3/8" 1.2 M HYDRAULIC	504834	1	
38	HOSE, 3/8:"(0.7M) HYDRAULIC	504833	1	
39	PHD 2T3/8X0.540 W9/16UNF-W9/16UNF	505173	1	

## SECTION 4 SAW HEAD

### 4.1 Middle Throat Screw

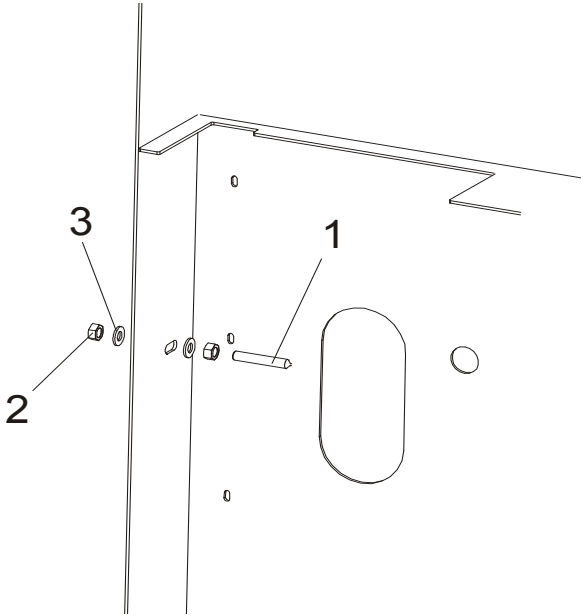

REF	DESCRIPTION (◆ Indicates Parts Available In Assemblies Only)	PART #	QTY.	
1	SCREW, M10X60-45H HEX SOCKET SET CONE POINT ZINC	F81003-87	1	
2	NUT, M10-8-B HEX ZINC	F81033-3	2	
3	WASHER, 10.5 FLAT ZINC	F81055-1	2	

#### 4.2 Water Lube Assembly (LMS)

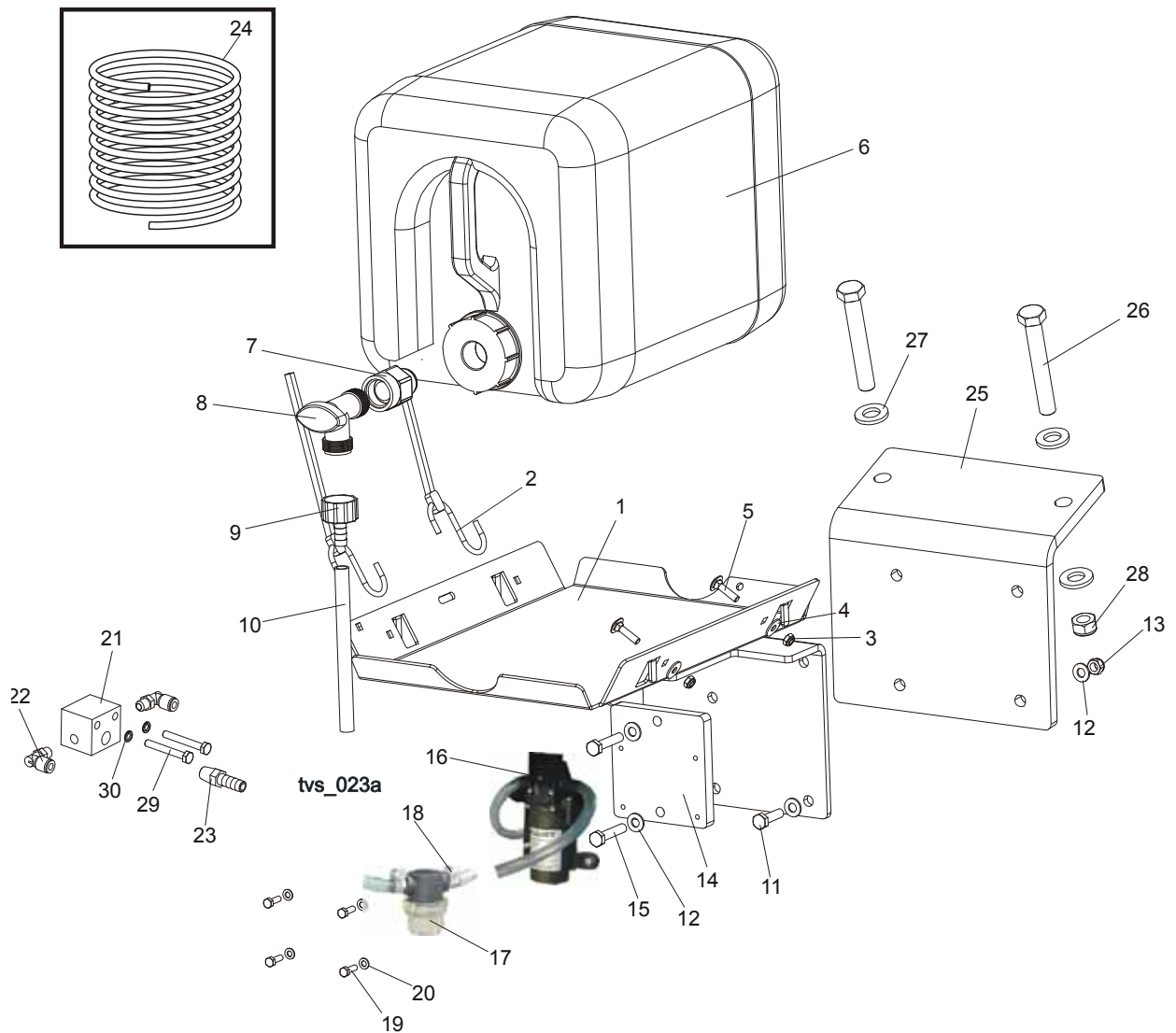

REF	DESCRIPTION (◆ Indicates Parts Available In Assemblies Only)	PART #	QTY.
	<b>BOTTLE KIT, LT20 WATER LUBE</b>	091036	1
1	TRAY WELDMENT, LT20 WATER LUBE	091033-1	1
2	STRAP, 20" RUBBER	P11668	2
3	NUT, M6-8-B HEX NYLON ZINC LOCK	F81031-2	2
4	WASHER, 6.5 ZINC FLAT	F81053-11	2
5	BOLT, M6X25-8.8 CARRIAGE HEAD ZINC	F81001-20	2
6	BOTTLE, 19 L WATER LUBE	014637	1
7	FITTING, 3/4FPT X 3/4MPT	014636	1
8	FITTING, WATER LUBE SHUTOFF VALVE	014100	1
9	FITTING, 5/8" NPT TO 3/8" HOSE BARB	014113	1
10	TUBING, WATER LUBE	R01885	2.1 m
11	BOLT, M8X30-8.8-B-HEX HEAD FULL THREAD ZINC	F81002-7	1
12	WASHER, 8.4 ZINC FLAT	F81054-1	3



13	NUT, M8-8-B Hex Nylon Zinc Lock	F81032-2	1	
14	BRACKET, LMS PUMP ZINC	098762-1	1	
15	BOLT, 8MM X 1.25 X 40MM HH ZINC	F81002-15	2	
16	<b>PUMP ASSEMBLY, PRESSURE LUBE</b>	033492	1	
	HEAD KIT, PRESSURE LUBE PUMP	033442	1	
	MOTOR KIT, PRESSURE LUBE PUMP 12V	033443	1	
17	<b>FILTER, PRESSURE LUBE</b>	033447	1	
	SCREEN KIT, MESH FILTER	033441	1	
18	<b>CLAMP, PLASTIC HOSE DIA. 8-12MM</b>	F81080-1	2	
19	<b>BOLT, M5X16-5.8-HEX HEAD FULL THREAD ZINC</b>	F81000-51	4	
20	<b>WASHER, M5, FLAT ZINC</b>	F81052-1	4	
21	<b>FITTING, TEE TVS LMS</b>	099213-1	1	
22	<b>FITTING, 1/8MPTX1/4TUBE,ELBOW,SWIVEL</b>	P09736	2	
23	<b>FITTING, 1/4NPT-3/8 BARB</b>	014685	1	
24	<b>HOSE, 1/4" OD X 6 1/2'</b>	033456	1	
25	<b>BRACKET, WATER TANK MOUNTING, PTD</b>	096178-1	1	
26	<b>BOLT M12X80-8.8</b>	F81004-46	2	
27	<b>WASHER, M12 , FLAT, ZINC</b>	F81056-1	4	
28	<b>NUT, M12, NYLON HEX ZINC LOCK</b>	F81034-1	2	
29	<b>BOLT, M6X45MM,HEX HEAD GR5(8.8)F/T ZINC</b>	F81001-6	2	
30	<b>WASHER, M6 SPLIT LOCK ZINC</b>	F81053-3	2	

### 4.3 Saw Head Decals

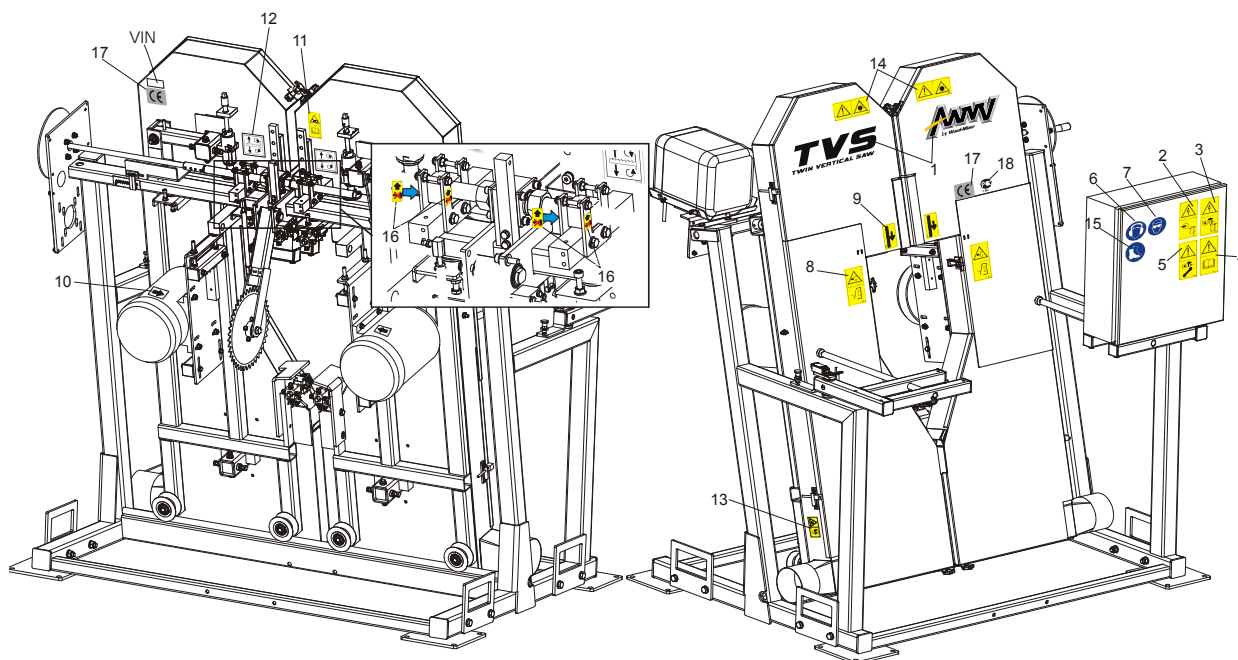

REF	DESCRIPTION (◆ Indicates Parts Available In Assemblies Only)	PART #	QTY.
	<b>DECALS KIT, COMPLETE, TVS, PICTOGRAMS</b>	099479	1
1	DECALS, TVS NAME	099422	1
2	DECAL, HIGH VOLTAGE IN ELECTRIC BOX	096316	1
3	DECAL, DISCONNECT POWER SUPPLY BEFORE OPENING THE BOX	096319	1
4	DECAL, READ THE MANUAL BEFORE OPERATING THE MACHINE	096317	1
5	DECAL, DISCONNECT POWER SUPPLY BEFORE SERVICING	098177	1
6	DECAL, EAR WARNING	S12005G	1
7	DECAL, EYE WARNING	S12004G	1
8	DECAL, CLOSE GUARDS PRIOR TO OPERATING THE MACHINE	099220	2
9	DECAL, BLADE MOVEMENT DIRECTION	096321	2
10	DECAL, MOTOR DIRECTION	S20097	2
11	DECAL, BLADE TENSION - INSTRUCTION, PICTOGRAM	099223	1
12	DECAL, BLADE ALIGNMENT	P11789	2
13	DECAL, SAW DUST PROTECTION, PICTOGRAM	099222	2
14	DECAL, CAUTION - LASER BEAM (OPTIONAL)	099504	2
15	DECAL, USE SAFETY BOOTS (PICTOGRAM)	501465	1
16	DECAL, DON'T ADJUST NUTS, PICTOGRAM	500031	4
	TABLES DECALS, <a href="#">See Section 5.7</a>		
17	DECAL, CE , CERTIFIED MACHINE (SMALL)	P85070	1
18	DECAL, GOST CERTIFIED MACHINE	099401	1

## 4.4 Blade Housing Cover

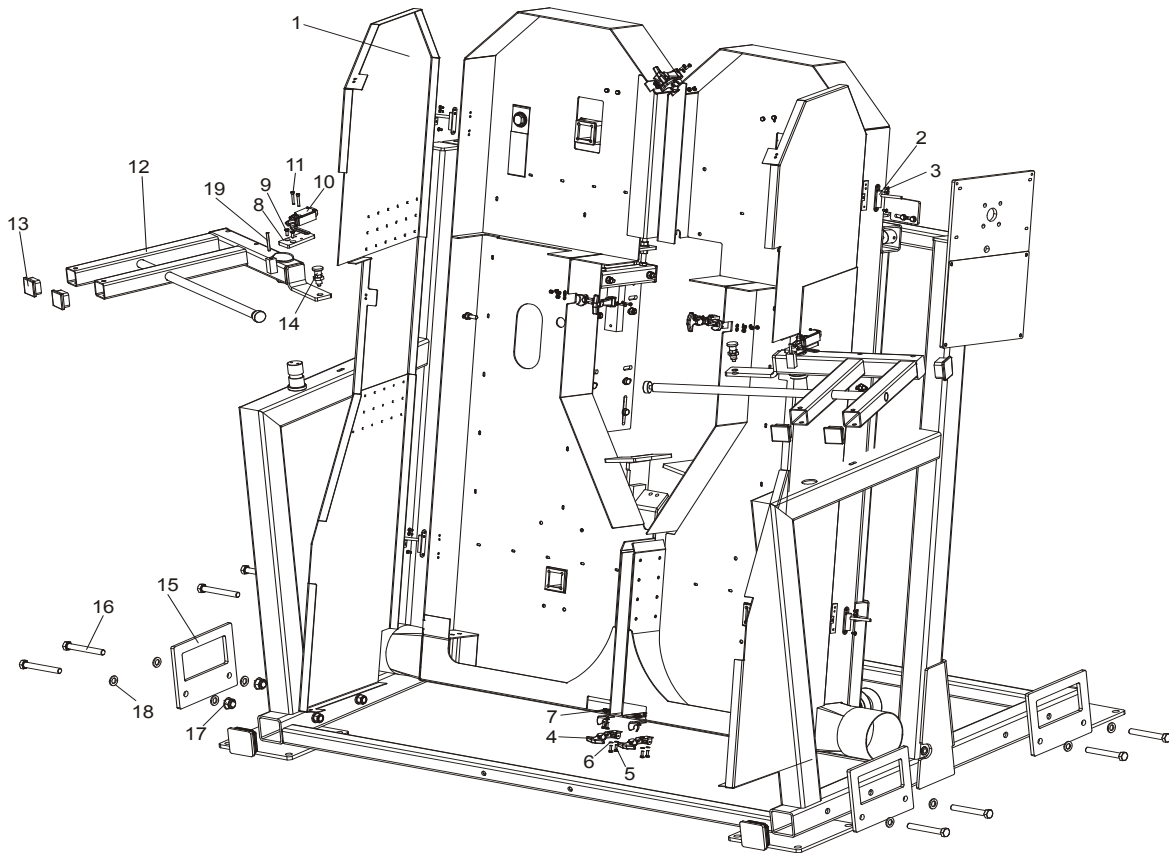

REF	DESCRIPTION (◆ Indicates Parts Available In Assemblies Only)	PART #	QTY.
1	COVER, BLADE HOUSING TVS LEFT WLDMT/PTD	098612-1 (LEFT)	1
	COVER, BLADE HOUSING TVS RIGHT WLDMT/PTD	096117-1 (RIGHT)	1
2	HINGE, COVER	096146	4
3	SCREW, M5X12- 5.8-B SLOTTED COUNTERSUNK ZINC	F81000-15	8
4	LATCH, FLEXIBLE DRAW	014829	6
5	BOLT, M5X16-5.8-HEX HEAD FULL THREAD ZINC	F81000-51	12
6	WASHER, M5, FLAT ZINC	F81052-1	24
7	NUT, M5-8- DIN 985 ZINC	F81030-2	12
8	FLAT BAR, LIMIT SWITCH MOUNTING ZINC	098760-1	2
9	SCREW, M6X16, HEX SOCKET HEAD CAP	F81001-21	4
10	SWITCH, GSCA 01S1 LIMIT	088407	2
11	BOLT, M5X35 8.8 HEX SOCKET HEAD CAP ZINC	F81000-73	4
12	ARM, CONTROL BOX TVS MOUNTING LEFT WLDMT/PTD	098611-1	2
	ARM, CONTROL BOX TVS MOUNTING RIGHT WLDMT/PTD	096370-1	2
13	CAP, 50X50(3-5MM THICK) #199274 SHR TUBE END	095371	4
14	PIN, DETENT	090197	2
15	PLATE, MOUNTING TVS	099145-1	4
16	BOLT, M16X120 -8.8- A2E ISO 24014	F81006-25	8

**4****Saw Head***Blade Housing Cover*

---

17	NUT, M16,HEX, NYLON ZINC LOCK	F81036-2	8	
18	WASHER, M16,FLAT ZINC	F81058-1	16	
19	PIN 5M6X50 DIN 6325 HRC60	F81048-8	2	

### 4.5 Saw Head Width Manual Adjustment Assembly

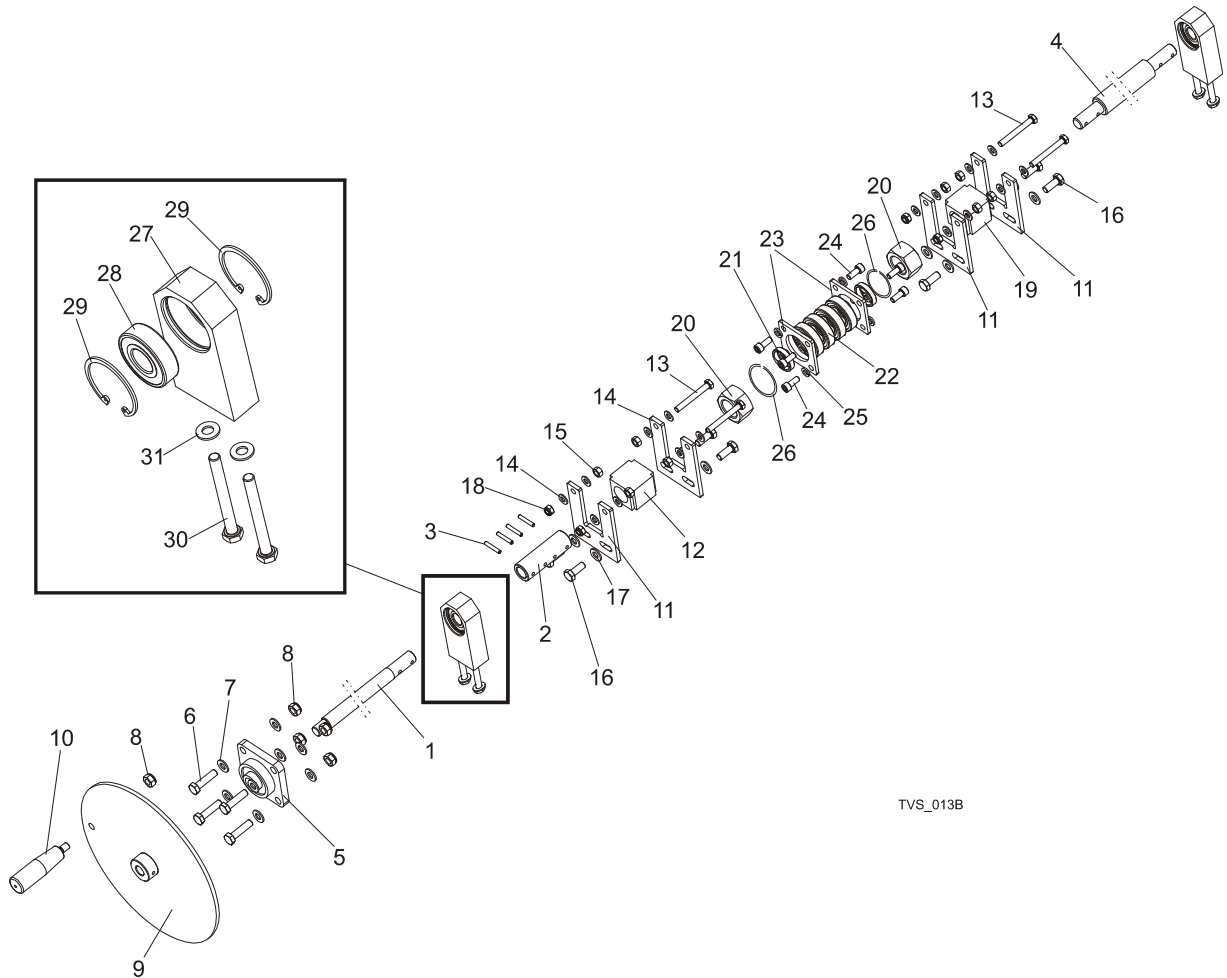

TVS\_013B

REF	DESCRIPTION (◆ Indicates Parts Available In Assemblies Only)	PART #	QTY.
	<b>SCREW, SAW HEAD WIDTH ADJUSTMENT TVS COMPLETE</b>	097664	1
1	ROD, SAW HEAD WIDTH ADJUSTMENT	096359-1	1
2	FASTENER, SAW HEAD WIDTH ADJUSTMENT SCREW	097665-1	1
3	PIN, 5X30 ROLL ZINC	F81044-21	4
4	SCREW, SAW HEAD WIDTH ADJUSTMENT TVS	096154-1	1
5	<b>BEARING, UCF 204 W/HOUSING</b>	097667	1
6	<b>BOLT, M10X40-8.8 HEX HEAD FULL THREAD ZINC</b>	F81003-16	4
7	<b>WASHER, M10 FLAT ZINC</b>	F81055-1	8
8	<b>NUT, M10 NYLON HEX ZINC LOCK</b>	F81033-1	5
9	<b>PLATE, SAW HEAD ADJUSTMENT SCREW WLDMT/PTD</b>	098617-1	1
10	<b>KNOB, PLASTIC CRANK HANDLE</b>	086338	1
11	<b>BRACKET, TURNBUCKLE MOUNT ZINC-PLATED</b>	096861-1	2
12	<b>TURNBUCKLE, M30 TVS</b>	101439	1
13	<b>BOLT, M8X65 8.8 HEX HEAD FULL THREAD ZINC</b>	F81002-9	2

14	WASHER, M8, FLAT,ZINC	F81054-1	8	
15	NUT, M8 HEXAGON,GRADE 5.8 FREE ZINC	F81032-1	4	
16	BOLT, M10-1.5X25MM HH GR8.8	F81003-11	4	
17	WASHER, FLAT, M10, ZINC	F81055-1	4	
18	NUT, M8,HEXAGON,NYLON LOCK ZINC	F81032-2	2	
19	TURNBUCKLE - M30 LH TVS	101440	1	
20	NUT, M30 HEX ZINC	F81038-3	2	
21	BUSHING, FI 34 X 38 X 8 SPACER	096356-1	2	
22	BEARING, 6006 2RSR	096191	4	
23	BRACKET, BEARING MOUNT BLOCK TVS-ZINC	096157-1	2	
24	BOLT, M8X20 -8.8-HEX SOCKET HEAD CAP ZINC	F81002-30	8	
25	WASHER, 8,2 ZINC	F81054-4	8	
26	WASHER, SPLIT LOCK Z30.5	F81068-1	2	
	<b>BLOCK, TVS SAW HEAD WIDTH ADJUSTMENT SCREW COMPLETE</b>	500012	2	
27	BLOCK, TVS SAW HEAD WIDTH ADJUSTMENT SCREW	500011-1	1	
28	BEARING, 6204 2RS-CX ROLLING	088447	1	
29	RING, W47 INSIDE RETAINING	089653	2	
30	BOLT, M8 X 75 8.8 FE/ZN5, PN-M/82101	F81002-91	2	
31	WASHER, 8.4 FLAT ZINC	F81054-1	2	

## 4.6 Saw Head Width Automatic Adjustment Assembly (Optional)

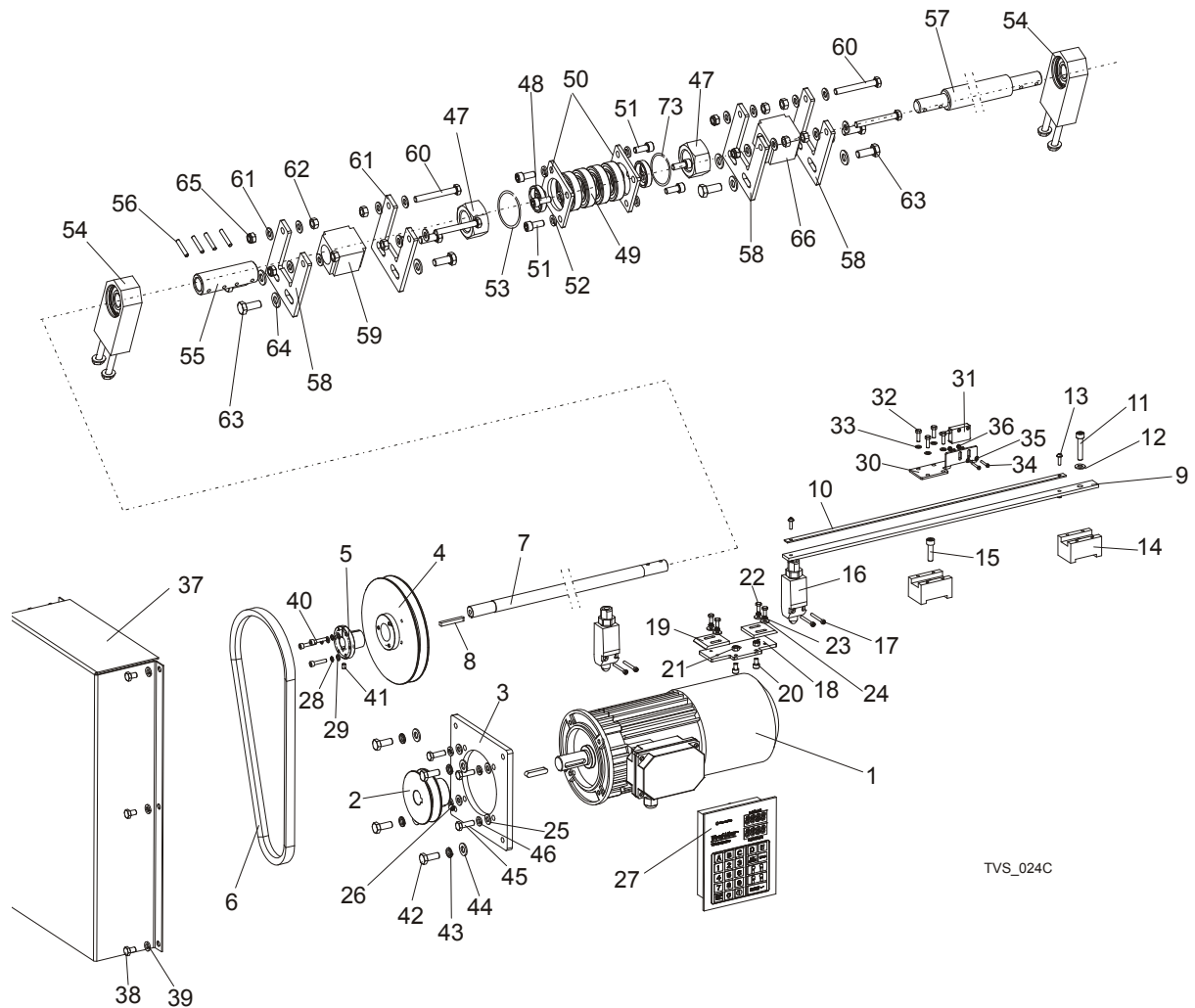

REF	DESCRIPTION (◆ Indicates Parts Available In Assemblies Only)	PART #	QTY.
	<b>SCREW, SAW HEAD WIDTH ADJUSTMENT TVS COMPLETE</b>	099185	1
	<b>SCREW, SAW HEAD WIDTH ADJUSTMENT TVS COMPLETE, TVS USA (UL)</b>	099185-4C	1
1	MOTOR, SKH90-8L1 HPS 0,55KW, 750RPM.400V	098891	1
1	MOTOR, SKh90-8L1 0,55kW, 750RPM.400V (TVS-USA)	099515-UL	1
2	SHEAVE, SAW HEAD WIDTH ADJUSTMENT, TVS	098116-1	1
3	BRACKET, MOTOR	099181-1	1
4	SHEAVE, TYPE B $\phi 180 \times \phi 30$	098117-1	1
5	BUSHING, TAPER	099317	1
6	BELT, TVS	099320	1
7	ROD, SAW HEAD WIDTH ADJUSTMENT	099180-1	1
8	KEY, AB 6X6X45 PARALLEL	089229	1
	GUARD, TVS W/MAGNETIC STRIP	502924	1
9	GUARD, TVS MAGNETIC STRIP	502694	1
10	STRIP, MB320 (1m) MAGNETIC	096014-1	1
11	SCREW, M8X40 -8.8- HEX SOCKED HEAD CAP ZINC	F81002-29	1
12	WASHER, M8, FLAT,ZINC	F81054-1	1

## 4

**Saw Head***Saw Head Width Automatic Adjustment Assembly (Optional)*

13	WASHER, 4,3 FLAT ZINC	F81051-2	1	
14	MOUNTING BLOCK WITH MAGNETIC STRIP	502923	2	
15	SCREW, M8X30 -8.8- HEX SOCKED HEAD CAP ZINC	F81002-31	1	
16	LIMIT SWITCH	089816	2	
17	BOLT, M3X20-5.8-A-PAN HEAD	F81000-8	4	
	LIMIT SWITCH ASSEMBLY	098992	1	
18	PLATE, LIMIT SWITCH MOUNT	098988-1	1	
19	BAR, LIMIT SWITCH FLAT	098989	2	
20	SCREW, M6X10 -8.8- HEX SOCKED HEAD CAP ZINC	F81001-12	2	
21	NUT, M6, HEXAGON,FREE, GRADE 5(8.8)ZINC	F81031-1	2	
22	BOLT, M5 X 12-5.8-HEX HEAD FULL THREAD ZINC	F81000-5	4	
23	WASHER, M5 SPLIT LOCK	F81052-2	4	
24	WASHER, 5,5 FLAT ZINC SPECIAL	F81052-3	4	
25	WASHER, M8, FLAT,ZINC	F81054-1	4	
26	SCREW, SET,M8X8-33H FE/ZN HEX SCKT HEAD	F81014-1	1	
27	CONTROLLER, TBS01	503467	1	
28	WASHER, M5 SPLIT LOCK	F81052-2	3	
29	WASHER, M5, FLAT ZINC	F81052-1	3	
30	BRACKET, SENSOR	502922-1	1	
31	SENSOR ASSY, MSK-320	096014	1	
32	BOLT, M5X16 -8.8- FHEX HEAD FULL THREAD ZINC	F81000-20	4	
33	WASHER, M5, FLAT ZINC	F81052-1	4	
34	SCREW, M3X20-5.8-A-PAN HEAD	F81000-8	2	
35	WASHER, 3,2 FLAT ZINC	F81050-2	4	
36	NUT, M3-6- HEX NYLON ZINC LOCK	F81028-2	2	
37	COVER, SAW HEAD WIDTH ADJUSTMENT TVS	098121-1	1	
38	BOLT, M8X12MM, HH FULL THREAD,GR8.8,ZINC	F81002-6	6	
39	WASHER, 8,2 SPLIT LOCK	F81054-4	6	
40	SCREW, M5X25-8.8-HEX SOCKED HEAD CAP ZINC	F81000-7	1	
41	SCREW, M6X8 PAN HEAD	F81013-1	1	
42	BOLT, M10-1.5X25MM HH GR8.8	F81003-11	4	
43	WASHER, M10 SPLIT LOCK ZINC	F81055-2	4	
44	WASHER, FLAT, M10, ZINC	F81055-1	4	
45	BOLT, M8 X 25MM HEX HEAD GR 5.8 ZINC	F81002-5	4	
46	WASHER, 8,2 SPLIT LOCK ZINC	F81054-4	4	
47	<b>NUT, M30 HEX ZINC</b>	F81038-3	2	
48	<b>BUSHING, FI 34 X 38 X 8 SPACER</b>	096356-1	2	
49	<b>BEARING, 6006 2RSR</b>	096191	4	
50	<b>BRACKET, BEARING MOUNT BLOCK TVS-ZINC</b>	096157-1	2	
51	<b>BOLT, M8X20 -8.8-HEX SOCKET HEAD CAP ZINC</b>	F81002-30	8	
52	<b>WASHER, 8,2 ZINC</b>	F81054-4	8	
53	<b>WASHER, SPLIT LOCK Z30.5</b>	F81068-1	2	
54	<b>BLOCK, TVS SAW HEAD WIDTH ADJUSTMENT SCREW COMPLETE</b>	500012	2	
55	<b>FASTENER, SAW HEAD WIDTH ADJUSTMENT SCREW</b>	097665-1	1	
56	<b>PIN, 5X30 ROLL ZINC</b>	F81044-21	4	
57	<b>SCREW, SAW HEAD WIDTH ADJUSTMENT TVS</b>	096154-1	1	



58	BRACKET, TURNBUCKLE MOUNT ZINC-PLATED	096861-1	2	
59	TURNBUCKLE, M30 TVS	101439	1	
60	BOLT, M8X65 8.8 HEX HEAD FULL THREAD ZINC	F81002-9	2	
61	WASHER, M8, FLAT,ZINC	F81054-1	8	
62	NUT, M8 HEXAGON,GRADE 5.8 FREE ZINC	F81032-1	4	
63	BOLT, M10-1.5X25MM HH GR8.8	F81003-11	4	
64	WASHER, FLAT, M10, ZINC	F81055-1	4	
65	NUT, M8,HEXAGON,NYLON LOCK ZINC	F81032-2	2	
66	TURNBUCKLE - M30 LH TVS	101440	1	

## 4.7 Saw Head Width Indicator

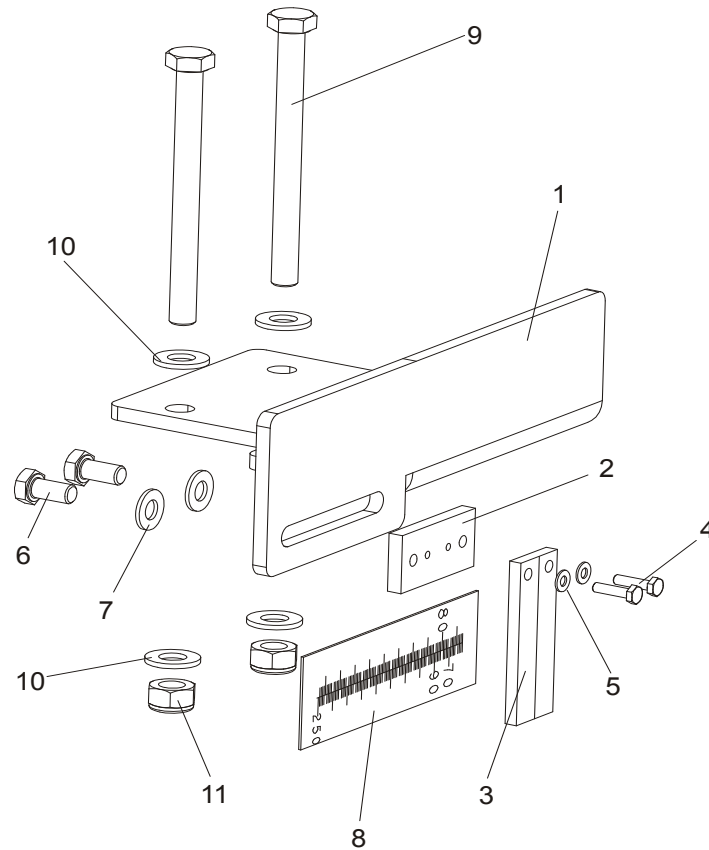

REF	DESCRIPTION (◆ Indicates Parts Available In Assemblies Only)	PART #	QTY.
	<b>SCALE INDICATOR, TVS COMPLETE</b>	098756	1
1	BRACKET, SCALE INDICATOR TVS	098622-1	1
2	BLOCK, BLADE WIDTH INDICATOR REDUCER	094438-1	1
3	INDICATOR, BLADE WIDTH SCALE	094821	1
4	BOLT, M4X16 5.8 HEX HEAD FULL THREAD ZINC	F81011-6	2
5	WASHER, 4,3 FLAT ZINC	F81051-2	2
6	BOLT, M8X16 -8.8-B-HEX HEAD FULL THREAD ZINC	F81002-20	2
7	WASHER, M8 FLAT ZINC	F81054-1	2
8	SCALE, TVS METRIC	098619	1
	SCALE, TVS INCH	502669	1
9	BOLT, M10X110 8.8 HEX HEAD ZINC	F81003-43	2
10	WASHER, M10 FLAT ZINC	F81055-1	4
11	NUT, M10 NYLON HEX ZINC LOCK	F81033-1	2

## 4.8 Saw Head Slide Brackets

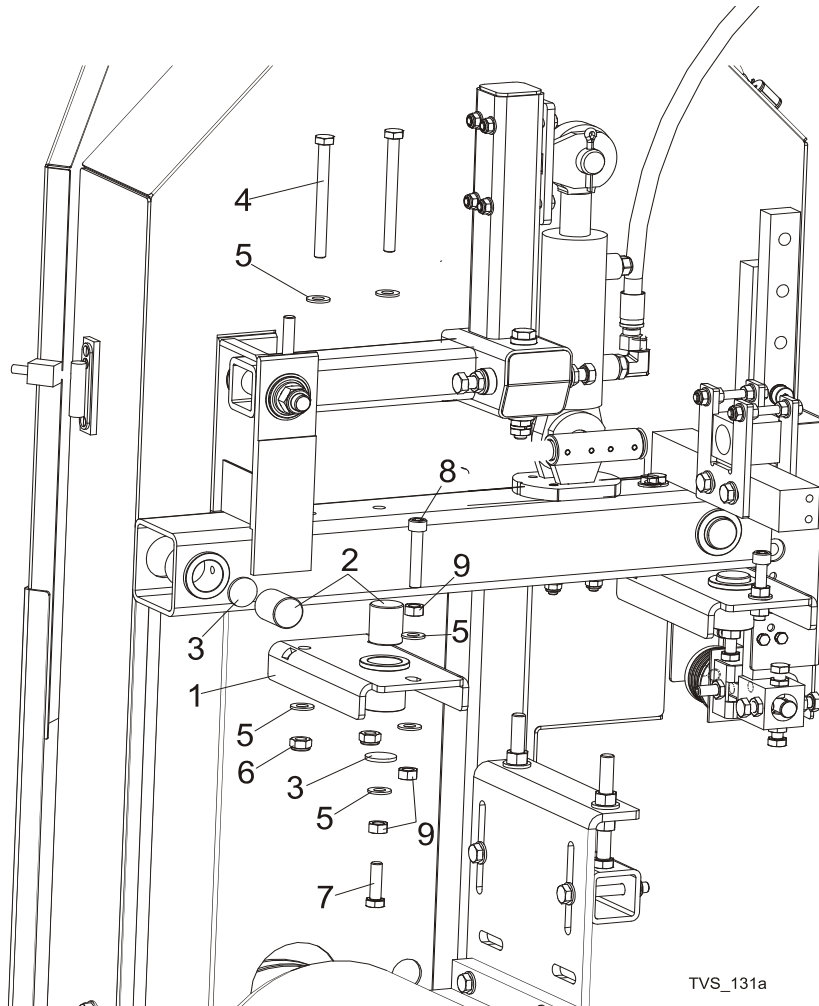

REF	DESCRIPTION (◆ Indicates Parts Available In Assemblies Only)	PART #	QTY.
1	BRACKET, SLIDE LOWER TVS	096838-1	2
2	ROD, SLIDE TVS	096128	4
3	WASHER, BUSHING SLIDE ZINC TVS	096129-1	4
4	BOLT, M10X110 8.8 ZINC	F81003-43	4
5	WASHER, 10.5 FLAT ZINC	F81055-1	9
6	NUT, M10-8-B NYLON HEX ZINC LOCK	F81033-1	4
7	BOLT, M10X35-8.8 HEX HEAD FULL THREAD ZINC	F81003-17	2
8	SCREW, M10X55-8.8 HEX SOCKET HEAD CAP	F81003-55	2
9	NUT, M10-8-B-FE	F81033-3	6

### 4.9 Hold-Down Roller

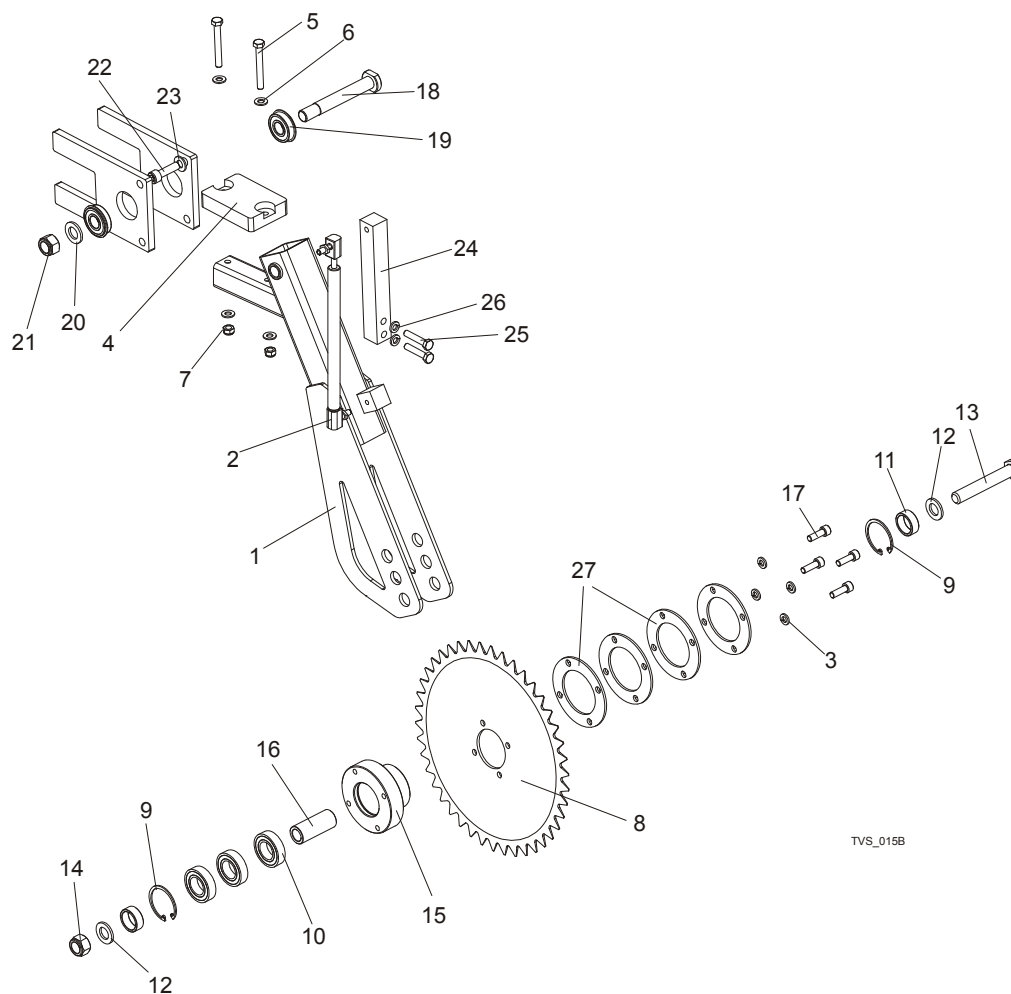

TVS\_015B

REF	DESCRIPTION (◆ Indicates Parts Available In Assemblies Only)	PART #	QTY.
	<b>ROLLER, HOLD-DOWN TVS</b>	097954	1
1	ARM, HOLD-DOWN REAR	502765-1	1
2	SPRING, 340N GAS COMPLETE	089212	1
3	WASHER, 8,2 SPLIT LOCK ZINC	F81054-4	4
4	BUMPER, GRENE 70 3201 0010. SHR RUBBER	094969	1
5	BOLT, M8 X 65MM HH GRADE 5.8 ZINC	F81002-3	2
6	WASHER, M8 FLAT ZINC	F81054-1	4
7	NUT, M8 HEX NYLON LOCK ZINC	F81032-2	2
8	WHEEL, LOG HOLD-DOWN TVS	096352-1	1
9	RING, W47 SPRING RETAINING	089653	2
10	BEARING, 6005 2RS CX	089652	3
11	BUSHING, FI 25,5 X 32X12 SPACER ZINC	097942-1	2
12	WASHER, M16 FLAT ZINC	F81058-1	2
13	BOLT, M16X100MM HEX HEAD FULL THRD ZINC	F81006-2	1
14	NUT, M16,HEX NYLON ZINC LOCK	F81036-2	1

15	SHAFT, LOG HOLD-DOWN WHEEL ZINC-PLATED	096351-1	1	
16	BUSHING, FI 25X16,5X60 SPACER ZINC	098610-1	1	
17	BOLT, M8X25 -8.8- HEX SOCKET HEAD CAP ZINC	F81002-21	4	
18	PIN, IDLER ARM MOUNT	086404	1	
19	BEARING W/SNAP RING 6203-2RS	086395	2	
20	WASHER, M16 FLAT ZINC	F81058-1	1	
21	NUT, M16 HEX NYLON ZINC LOCK	F81036-2	1	
22	BOLT, M10X35 HEX SOCKET HEAD CAP ZINC	F81003-56	1	
23	WASHER, M10 FLAT ZINC	F81055-1	1	
24	BRACKET, GAS SPRING ZINC	096160-1	1	
25	BOLT, 8MM X 1.25 X 40MM HH ZINC	F81002-15	2	
26	WASHER, 8,2 SPLIT LOCK ZINC	F81054-4	2	
27	SPACER	099530-1	4	

## 4.10 Blade Drive Motor

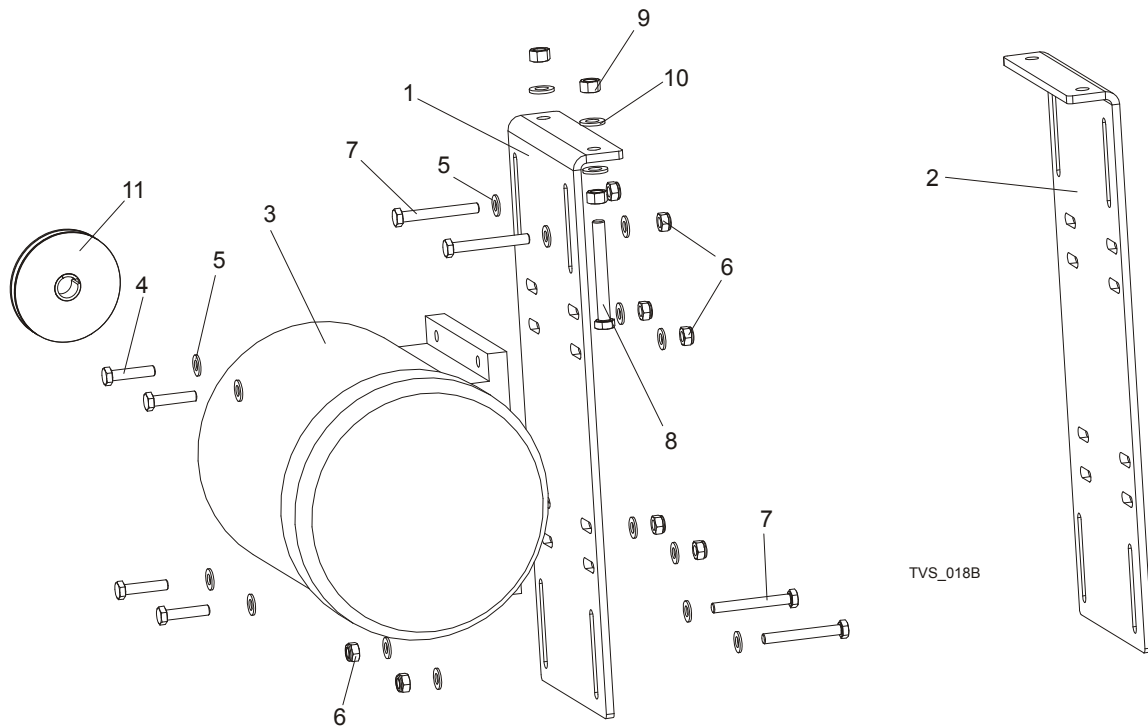

REF	DESCRIPTION (◆ Indicates Parts Available In Assemblies Only)	PART #	QTY.
1	PLATE, MOTOR MOUNT RIGHT - PTD	096123-1	1
	PLATE, MOTOR MOUNT RIGHT - PTD (TVS-USA)	099398-1	1
2	PLATE, MOTOR MOUNT LEFT - PTD	098436-1	1
	PLATE, MOTOR MOUNT LEFT - PTD (TVS-USA)	099397-1	1
3	MOTOR, 7,5KW SG132S-2B HM	090993	2
	MOTOR, 11KW PSg-132 S2 - HM	089049	2
	MOTOR, 12kW 1LA91312LA60 (USA)	P85186-UL	2
	MOTOR, 15KW(20HP)380-420V ELECTRIC (TVS-USA)	086856-UL	2
4	BOLT, M10X45MM HEX HEAD FULL THRD ZINC	F81003-3	8
5	WASHER, M10 FLAT ZINC	F81055-1	32
6	NUT, M10 NYLON HEX ZINC LOCK	F81033-1	16
7	BOLT, M10X80 -8.8- HEX ZINC	F81003-50	8
8	BOLT, M12X100 8.8 HEX HEAD FULL THREAD ZINC	F81004-45	4
9	NUT, M12 HEX GRADE 5.8 ZINC	F81034-1	4
10	WASHER, M12 FLAT ZINC	F81056-1	8
11	PULLEY, SPB $\Phi$ 140X1/ $\Phi$ 38 (F02325+T31079)	500571 <sup>1</sup>	2
	PULLEY, SPB $\Phi$ 170X1/ $\Phi$ 38 (F01794+T31079)	500575 <sup>2</sup>	2
	PULLEY, SPB190/1 W/2012/38 TAPER SPLIT BUSHING	099601 <sup>3</sup>	2
	PULLEY, SPB125X1/FI38 F02319+T31079 TAPER SPLIT BUSHING	501556 <sup>4</sup>	2
	PULLEY, $\Phi$ 150/ FI42 F02329+T31081 (TVS-USA)	099503	1

<sup>1</sup> Standard Equipment. Blade Linear Velocity  $v=20.5$  m/s.

<sup>2</sup> Blade Linear Velocity  $v=25$  m/s.

- 
- <sup>3</sup> Blade Linear Velocity  $v=28$  m/s.  
<sup>4</sup> Blade Linear Velocity  $v=23$  m/s.

4.11 Saw Head Support Rollers

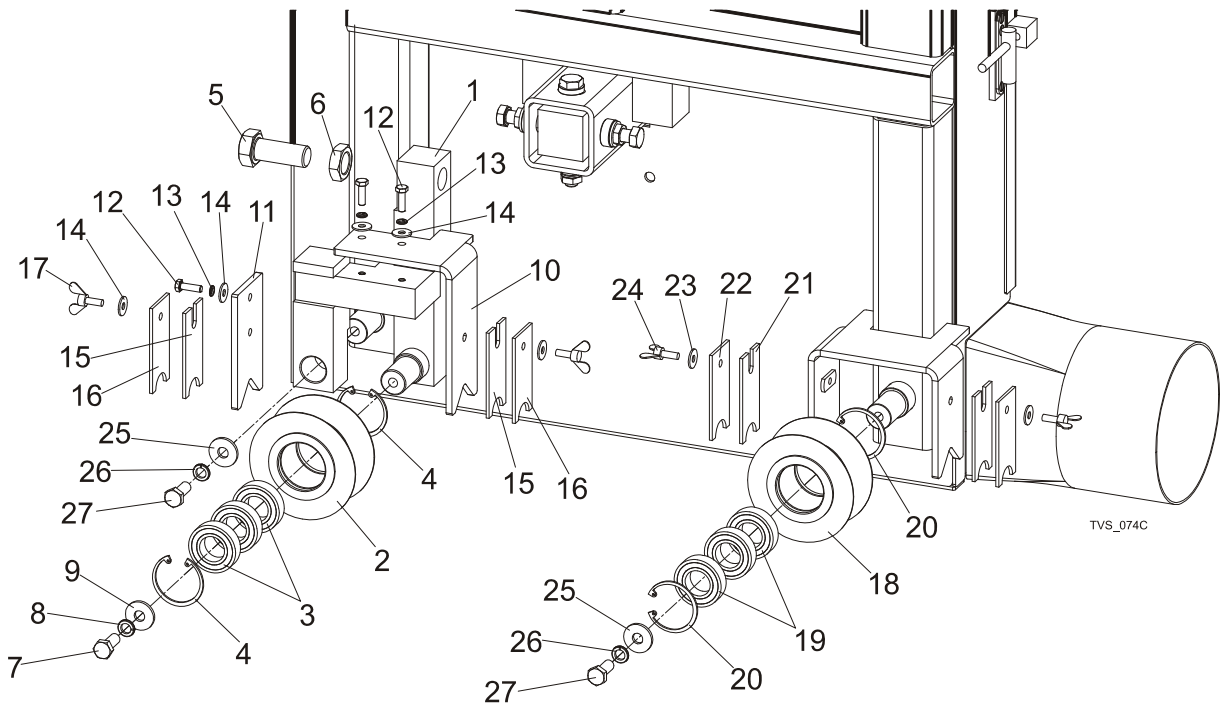

REF	DESCRIPTION (◆ Indicates Parts Available In Assemblies Only)	PART #	QTY.
	<b>ROLLER, TVS SAW HEAD ADJUST SUPPORT, COMPLETE</b>	100179	2
1	SUPPORT, TVS SAW HEAD ROLLER	100177-1	1
	ROLLER, TVS SAW HEAD SUPPORT, COMPLETE	096835	1
2	ROLLER, TVS SAW HEAD SUPPORT, PTD	096834-1	1
3	BEARING, 6005 2RS CX	089652	3
4	RING, W47 SPRING RETAINING	089653	2
5	BOLT, M10X1,5X50-8.8-B ZINC-PLATED	F81007-2	1
6	NUT, M20X1,5 ZINC-PLATED THIN	F81037-7	1
7	BOLT, M10 X 25 8.8 FE/ZN5, PN-M/82105	F81003-31	1
8	WASHER, 10.2 SPLIT LOCK ZINC	F81055-2	1
9	WASHER, 10.5 ZINC FLAT SPECIAL	F81055-6	1
10	SUPPORT, WIPER RIGHT	101092-1	1
11	SUPPORT, WIPER LEFT	101093-1	1
12	BOLT, M6X20-8.8 HEX HEAD FULL THREAD ZINC	F81001-2	3
13	WASHER, Z6.1 SPLIT LOCK ZINC	F81053-3	3
14	WASHER, 6.5 FLAT ZINC	F81053-11	5
15	WIPER, TOP RAIL	101090	2
16	PLATE, TRACK WIPER PTD	088559-1	2
17	BOLT, M6X16 BN276	F81001-16	2
	<b>ROLLER, TVS SAW HEAD SUPPORT, COMPLETE</b>	096835	1
18	ROLLER, TVS SAW HEAD SUPPORT, PTD	096834-1	1
19	BEARING, 6005 2RS CX	089652	3



<b>20</b>	RING, W47 SPRING RETAINING	089653	2	
<b>21</b>	<b>WASHER, 6.5 FLAT ZINC</b>	F81053-11	5	
<b>22</b>	<b>WIPER, TOP RAIL</b>	101090	2	
<b>23</b>	<b>PLATE, TRACK WIPER PTD</b>	088559-1	2	
<b>24</b>	<b>BOLT, M6X16 BN276</b>	F81001-16	2	
<b>25</b>	<b>BOLT, M10 X 25 8.8 FE/ZN5, PN-M/82105</b>	F81003-31	2	
<b>26</b>	<b>WASHER, 10.2 SPLIT LOCK ZINC</b>	F81055-2	2	
<b>27</b>	<b>WASHER, 10.5 ZINC FLAT SPECIAL</b>	F81055-6	2	

**4.12 Electric Box**



REF	DESCRIPTION (◆ Indicates Parts Available In Assemblies Only)	PART #	QTY.
	<b>ELECTRIC BOX TVS</b>	096222	1
	<b>ELECTRIC BOX TVS USA</b>	096222-4	1
<b>1</b>	SWITCH ABB OT45E3	095473	1
	HANDWHEEL OHB2AJ ABB	088265-1	1
	AXIS OXS5X160 ABB	088265-2	1
<b>2</b>	CONTROL LIGHT, WHITE	090488	1

### 4.13 Control Box

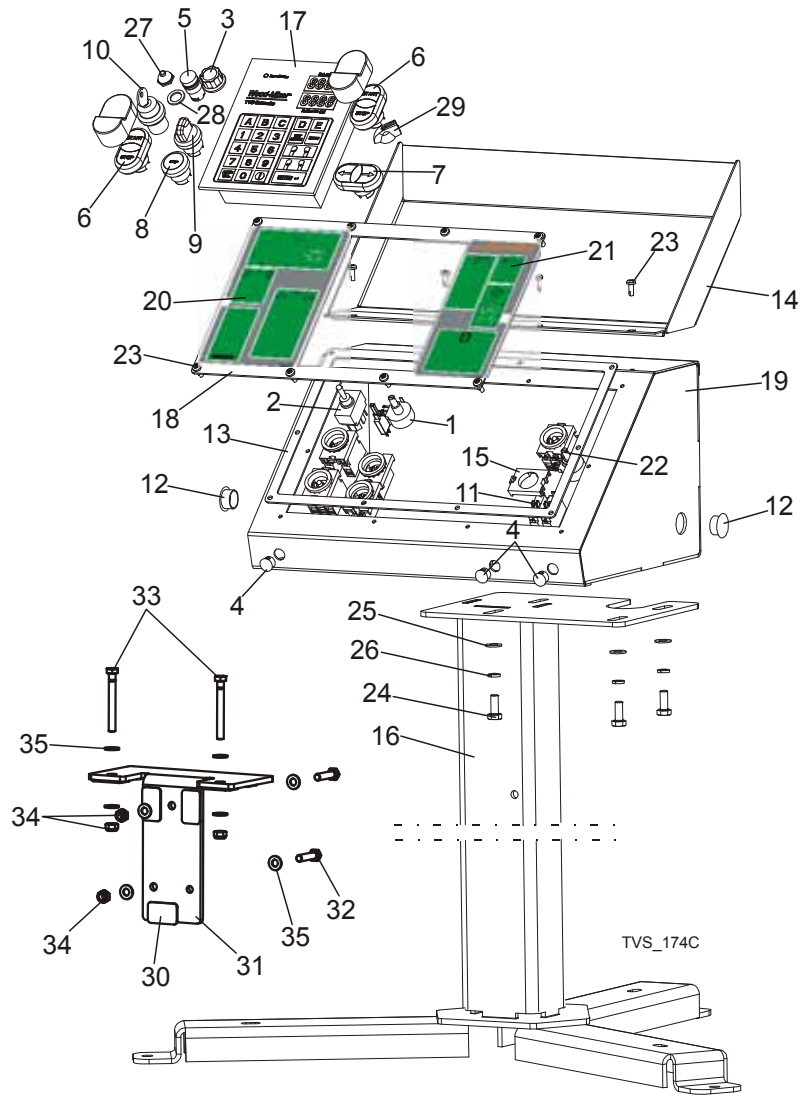

REF	DESCRIPTION (◆ Indicates Parts Available In Assemblies Only)	PART #	QTY.
	<b>CONTROL BOX, TVS COMPLETE</b>	503540	1
1	POT, 500K 2W 10% CP PANEL MOUNT	024553	1
2	SWITCH, DPDT ON/OFF/ON 15A TOGGLE	024588	1
3	KNOB, 1/4 ID FLUTED ROUND PLASTIC	033478	1
4	CAP, DP 812 HEJMAN 12.7 DIA. HOLE	086773	3
5	CONTROL BULB XB6 AV 3BB	087348	1
6	SWITCH, 24V START/STOP	090452	2
7	BUTTON, M22-DD-S-X7/X7	090917	1
8	SWITCH, M22 STOP	090926	1
9	SWITCH, M22 3 POSITIONS, ILLUMINATED	091359	1
10	SWITCH, M22 3-POSITION KEY	091361	1

11	ELEMENT, M22-K10 CONTACT	091362	2	
12	CAP, 22.2 HOLE SR1086	093544	2	
13	GASKET, LT20 CONTROL BOX	097132	1	
14	COVER, LT20/40 CONTROL BOX - COMPLETE	097135-1	1	
15	LINK, M22-A	100905	1	
16	STAND, LT20B CONTROL BOX	501651-1	1	
17	CONTROLLER, TBS01 SETWORKS	503467 <sup>1</sup>	1	
	CAP, TVS CONTROL BOX	504378	1	
	DECAL, TVS CONTROL BOX	504379	1	
	MEMBRANE CONTROLLER TVS	083731	1	
18	PANEL, TVS FRONT CONTROL	503535-1	1	
19	CONTROL BOX, TVS	503536-1	1	
20	DECAL, TVS CONTROL BOX LEFT	503538A	1	
21	DECAL, TVS CONTROL BOX RIGHT	503538B	1	
22	POTENTIOMETER, 1K LTAGA	E20519	1	
23	BOLT, #10-24 X 1/2 PH PAN HD, TYPE 23	F05015-17	12	
24	BOLT, M8X20-8.8-B HEX HEAD FULL THREAD	F81002-4	4	
25	WASHER, 8.4 FLAT ZINC	F81054-1	4	
26	WASHER 8,2 FE/ZN9	F81054-4	4	
27	BOOT, TOGGLE SWITCH	P02575	1	
28	WASHER, 1/2X3/4X1/16 NYLON	P05251-1	1	
29	KNOB, SPEED CONTROL	P06257	1	
	<b>BRACKET, TVS CONTROL BOX TRANSPORT COMPLETE</b>	504894	1	
30	WASHER, CORK SELF-ADHESIVE	502881	7	
31	BRACKET, TVS CONTROL BOX	504895-1	1	
32	BOLT, M8X35-8.8 HEX HEAD FULL THREAD ZINC	F81002-13	2	
33	BOLT, M8X70 8.8 HEX HEAD ZINC	F81002-71	2	
34	NUT, M8-8-B HEX NYLON ZINC LOCK	F81032-2	4	
35	WASHER, 8.4 FLAT ZINC	F81054-1	8	

<sup>1</sup> In machines with Automatic Saw Head Width Adjustment Option only.

### 4.14 Laser Assembly (Optional)

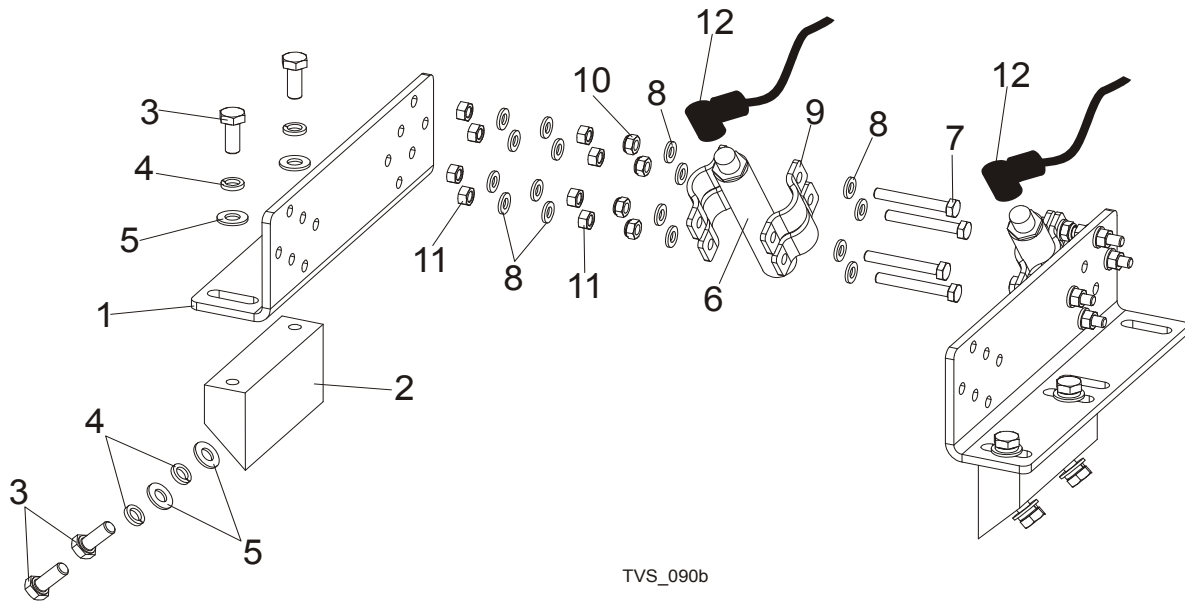

LP.	OPIS (◆ wskazuje części dostępne jedynie w zespołach )	NR CZĘŚCI	SZT.
	<b>TVS LASER ASSEMBLY, COMPLETE</b>	100079	1
1	PLATE, TVS LASER MOUNTING	098304	2
2	BRACKET, TVS LASER	098303	2
3	BOLT, M8X20MM, HH, GR 8.8, FULL THRD, ZINC	F81002-1	8
4	WASHER, 8.2 SPLIT LOCK ZINC	F81054-4	8
5	WASHER, 8.4 FLAT ZINC	F81054-1	8
6	LASER, Z5M18B-F-532-IG90 GREEN - LINEAR	501025	2
7	BOLT, M6X45-8.8 HH, FULL THRD ZINC	F81001-45	8
8	WASHER, M6, FLAT, ZINC	F81053-1	32
9	BRACKET, 3/8" (12-17) TUBE MOUNTING	099872	4
10	NUT, M6-8-B HEX, NYLON LOCK ZINC	F81031-2	8
11	NUT, M6, HEXAGON, FREE, GRADE 5(8.8) ZINC	F81031-1	16
12	<b>CABLE, 5M SAFETY SWITCH</b>	087652	2

## SECTION 5 INFEED & OUTFEED FLAT TABLES

### 5.1 TVS FT Infeed Table

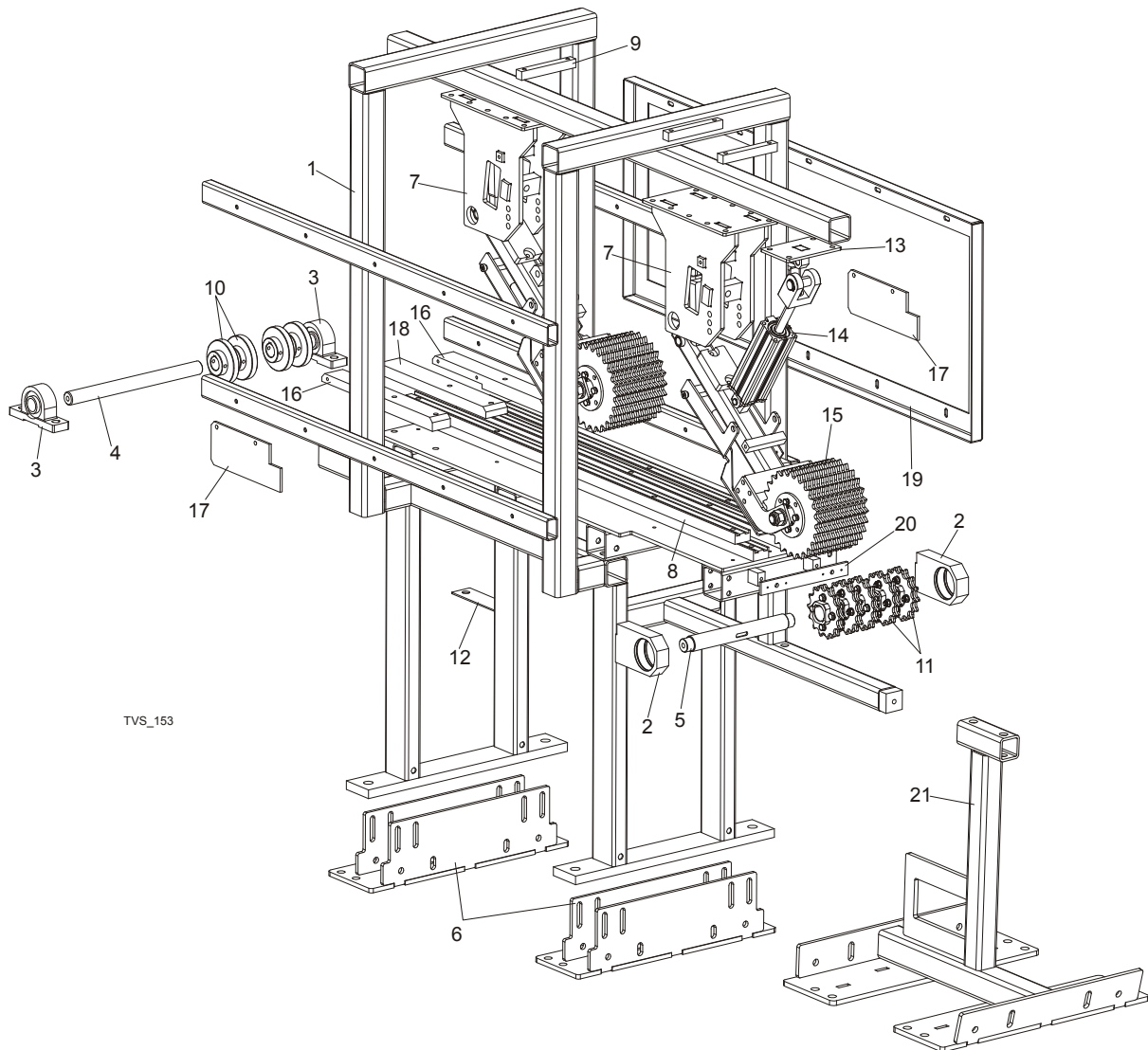

REF	DESCRIPTION (◆ Indicates Parts Available In Assemblies Only)	PART #	QTY.
	<b>INFEED TABLE, TVS FT COMPLETE</b>	<b>100092</b>	<b>1</b>
1	TABLE, TVS FT INFEED	100090-1	1
2	BLOCK, SHAFT BEARING MOUNT	099876-1	2
3	BEARING, UCP 206 CX W/HOUSING	099254	2
4	COUNTERSHAFT, TVS FT	100114	1
5	SHAFT, TVS FT MIDDLE	100115	1
6	FOOT, TVS FT TABLE ADJUST	100244-1	2
7	SUPPORT, HOLD-DOWN ROLLER UPPER	100746-1	2

8	BAR, 16B-1 1.235M CHAIN GUIDE	100753	4	
9	BAR, HOLD-DOWN ROLLER SUPPORT MOUNT	100757-1	4	
10	WHEEL, CHAIN TENSION 16B	101088-1	4	
11	SPROCKET, 14Z D30 COMPLETE	101077	4	
12	PLATE, UCP206 MOUNT DISTANCE	101198	1	
13	BRACKET, CYLINDER UPPER	101204-1	2	
14	CYLINDER, PNEUMATIC, ECDQ2A50-200DCM + Y-G05 + CO-D050	508396	2	
15	ROLLER, FRONT	100569	2	
16	ROD, COVER SHORT FLAT	501510	2	
17	PLATE, SIDE GUIDE	100183	2	
18	ROD, COVER MIDDLE FLAT	501513	1	
19	VERTICAL TUBE, SENSOR BRACKET	101209	2	
20	BAR, SCRAPER MOUNT	501516-1	1	
21	<b>LINK, TVS FT INFEED TABLE</b>	100245-1	1	
	<b>FRONT CHAIN, 153 LINKS, 3886MM, TVS FT</b>	504961	6	
	<b>BACK CHAIN, 129 LINKS, 3277MM, TVS FT</b>	504962	4	
	<b>MIDDLE CHAIN, 189 LINKS, 4800MM, TVS FT</b>	504963	1	

## 5.2 TVS FT Outfeed Table

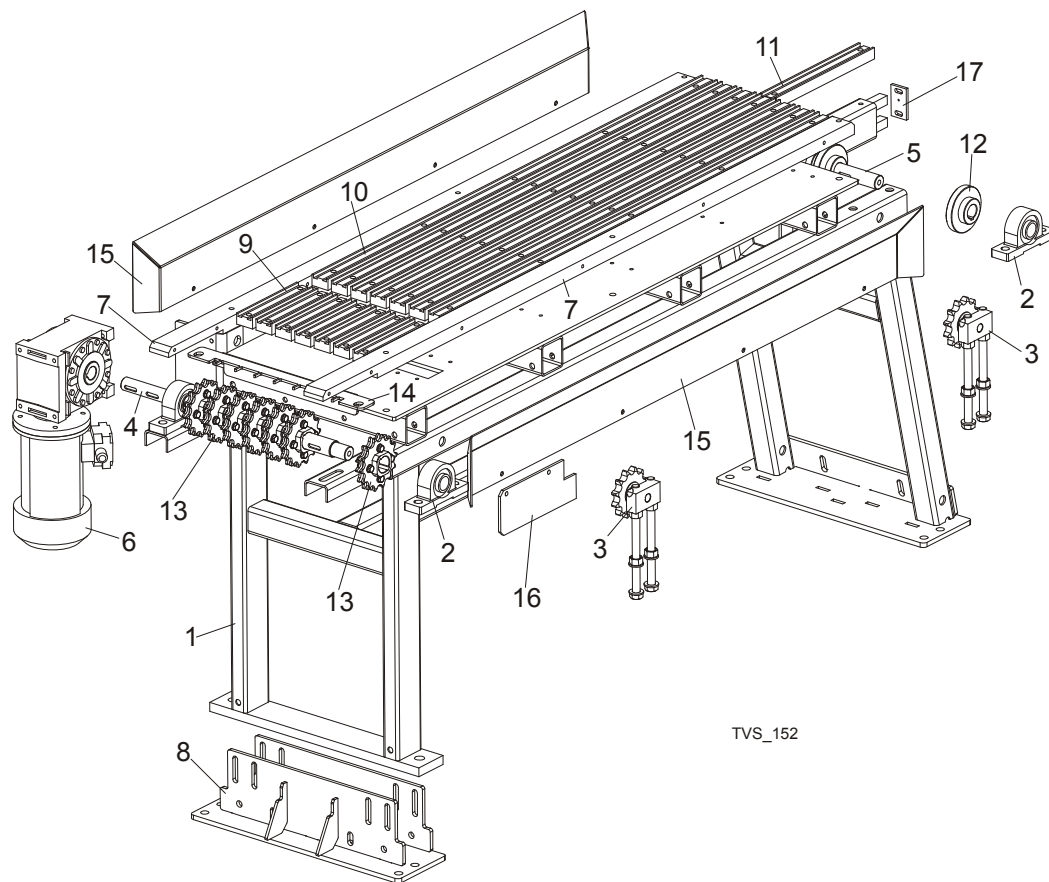

REF	DESCRIPTION (◆ Indicates Parts Available In Assemblies Only)	PART #	QTY.
	<b>OUTFEED TABLE, TVS FT COMPLETE</b>	<b>100091</b>	<b>1</b>
1	TABLE, TVS FT OUTFEED	100081-1	1
2	BEARING, UCP 206 CX W/HOUSING	099254	4
3	COMPLETE SHORT CHAIN TENSIONER	099832	2
4	SHAFT, TVS FT DRIVE	100116	1
5	SHAFT, TVS FT IDLE SIDE	100117	1
6	MOTOREDUCER, RA-06/39/D4/SN/V6 RESAW	092075	1
7	ROD, SIDE GUARD CROSS FLAT	100182	2
8	FOOT, TVS FT TABLE ADJUST	100244-1	1
9	BAR, 16B-1 0.2M OUTFEED SIDE CHAIN GUIDE	100112	7
10	BAR, 16B-1 1.290M CHAIN GUIDE	100754	7
11	BAR, 16B-1 0.325M CHAIN GUIDE	100755	1
12	WHEEL, CHAIN TENSION 16B	101088-1	6
13	SPROCKET, 14Z D30 COMPLETE	101077	7
14		101395	1
15	GUARD, TVS FT SIDE	101438	2
16	PLATE, SIDE GUIDE	100183	1
17	BAR, SCRAPER MOUNT	501518-1	1



### 5.3 Roller Infeed & Outfeed Table

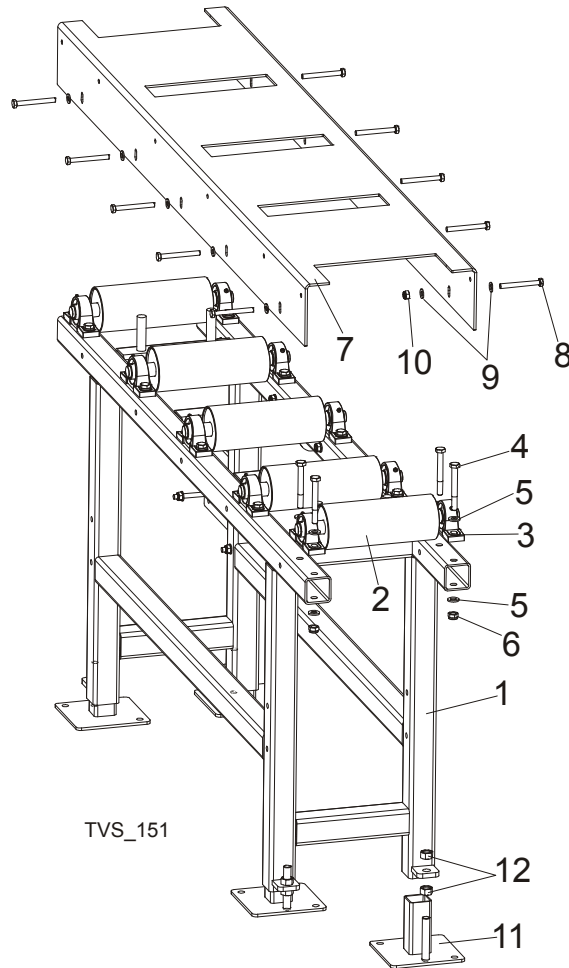

REF	DESCRIPTION (◆ Indicates Parts Available In Assemblies Only)	PART #	QTY.
	<b>TABLE, ROLLER INFEEED &amp; OUTFEED</b>	<b>099170</b>	<b>2</b>
1	FRAME, SVS INFEEED & OUTFEED TABLE	099168-1	1
2	ROLLER, SVS FEED	098140-1	5
3	BEARING, UCP 205 CX W/HOUSING	088468	10
4	BOLT, M12x100-8.8 HEX HEAD ZINC	F81004-3	20
5	WASHER, 13 FLAT ZINC	F81056-1	40
6	NUT, M12-8 HEX NYLON ZINC LOCK	F81034-2	20
7	PLATE, SVS TABLE TOP	099167-1	1
8	BOLT, M10x90 -8.8-B HEX HEAD ZINC	F81003-66	10
9	WASHER, 10.5 FLAT ZINC	F81055-1	20
10	NUT, M10-8-B HEX NYLON ZINC LOCK	F81033-1	10
11	FOOT ASSEMBLY, TABLE LEG	099281-1	4
12	NUT, M16-5.8 HEX ZINC	F81036-1	8

### 5.4 Hold-Down Roller Kit

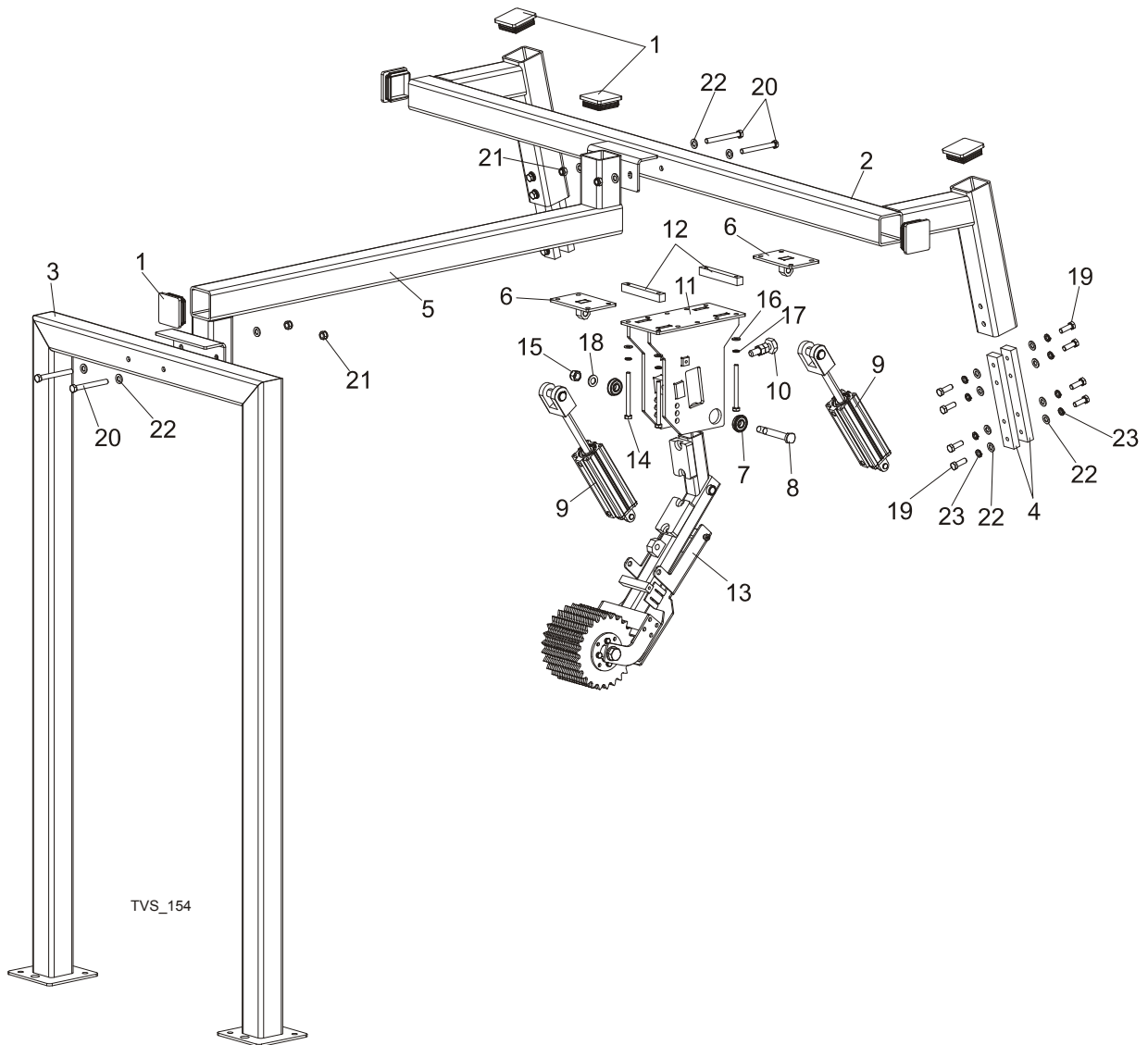

REF	DESCRIPTION (◆ Indicates Parts Available In Assemblies Only)	PART#	QTY.
	<b>HOLD-DOWN ROLLER KIT, TVS FT</b>	<b>101457</b>	<b>1</b>
1	Cap, Hold-Down Roller Frame	089644	6
2	Support Construction, Hold-Down Roller Rear	100731-1	1
3	Frame, Hold-Down Roller Construction Front	100738-1	1
4	Bar, Hold-Down Roller Support Mount	100756-1	4
5	Middle Tube, Hold-Down Roller Construction (Short Table)	101181-1	1
	Hold-Down Roller, TVS Additional Complete	101450	1
6	Bracket, Cylinder Upper	101204-1	2
7	Bearing w/Snap Ring LT15 6203-2RS	086395	2
8	Bolt, Arm Bearnig Mount	086404	1

<b>9</b>	Cylinder, Pneumatic		2	
<b>10</b>	M16 Bolt & 2 Nuts	093710	1	
<b>11</b>	Support, Hold-Down Roller Upper	100746-1	1	
<b>12</b>	Bar, Hold-Down Roller Support Mount	100757-1	2	
<b>13</b>	Roller, Front	100569	1	
<b>14</b>	Bolt, M10 X 115-8.8 Zinc Lock	F81003-19	4	
<b>15</b>	Nut, M16 Hex Nylon Zinc Lock	F81036-2	1	
<b>16</b>	Washer, 10.5 Flat Zinc	F81055-1	4	
<b>17</b>	Washer, 10.2 Split Lock Zinc	F81055-2	4	
<b>18</b>	Washer, 17 Flat Zinc	F81058-1	1	
<b>19</b>	Bolt, M12x35-8.8 Zinc Hex Head Full	F81004-24	16	
<b>20</b>	Bolt, M12x110-8.8 Zinc Hex Head Full	F81004-47	4	
<b>21</b>	Nut, M12-8 Hex Nylon Zinc Lock	F81034-2	4	
<b>22</b>	Washer, 13 Flat Zinc	F81056-1	24	
<b>23</b>	Washer, Z12.2 Split Lock Zinc	F81056-2	16	

## SECTION 6 INCLINE LOG DECK

### 6.1 Infeed Assembly

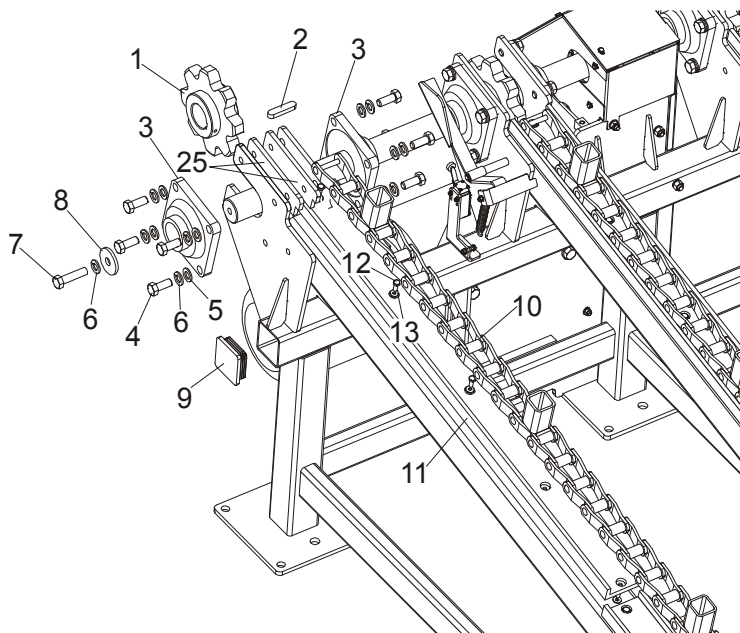

TVS\_039\_A

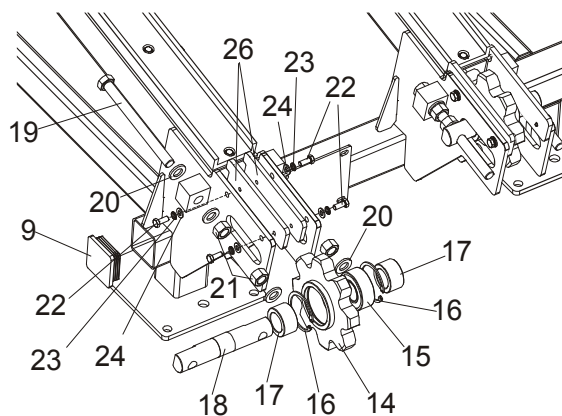

REF	DESCRIPTION (◆ Indicates Parts Available In Assemblies Only)	PART #	QTY.
	<b>TVS INCLINE LOG DECK</b>	097999	1
1	SPROCKET, Z8 OXIDIZED	089888-1	4
2	KEY, A16X10X70 PARALLEL	098029	4
3	BEARING, UCF 211W/HOUSING (55 DIA. SHAFT)	089889	8
4	BOLT, M16x40-8.8 HEX HEAD FULL THREAD ZINC	F81006-13	32
5	WASHER, 17 FLAT ZINC	F81058-1	32
6	WASHER, 16.3 SPLIT LOCK ZINC	F81058-2	32
7	BOLT, M16x65-8.8-B HEX HEAD FULL THREAD ZINC	F81006-1	4
8	WASHER, TVS SPECIAL	098012-1	2

9	CAP, FRAME TUBE	089644	4	
10	CHAIN, TVS INCLINE LOG DECK 5940mm 89 LINKS	504582	4	
11	CHANNEL, UHMW CONVEYOR	033722	8	
12	BOLT, M8x20-5.8 HEX HEAD FULL THREAD ZINC	F81002-1	40	
13	WASHER, 6.5 SPECIAL FLAT ZINC	F81053-11	40	
14	SPROCKET, Z8 REAR OXIDIZED	089919-1	4	
15	BEARING, 3208B.2RSR.TVH FAG	088449	4	
16	RING, W80 INSIDE RETAINING	F81090-25	8	
17	BUSHING, SPROCKET SPACER	089916-1	8	
18	SHAFT, CHAIN TENSION SPROCKET	089915-1	4	
19	BOLT, M20x240-8.8 HEX HEAD FULL THREAD ZINC	F81007-1	8	
20	WASHER, 21 FLAT ZINC	F81059-2	24	
21	NUT, M20-8 HEX ZINC	F81037-1	16	

## 6.2 Additional Grid, Option For TVS Incline Log Deck

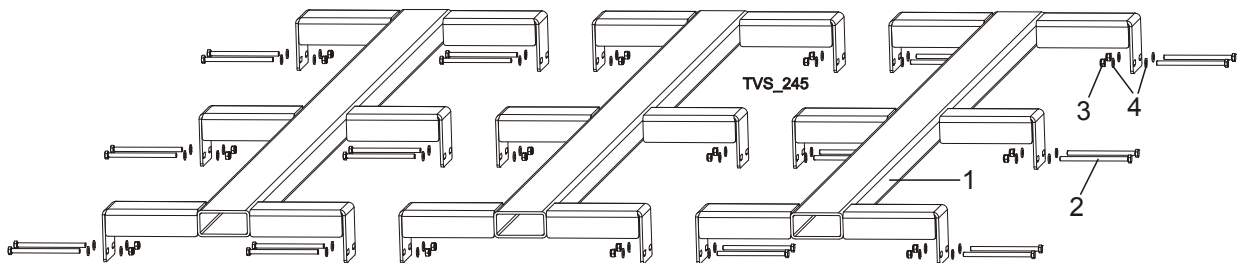

REF	DESCRIPTION (◆ Indicates Parts Available In Assemblies Only)	PART #	QTY.	
	<b>GRID ADDITIONAL TVS INCLINE LOG DECK COMPLETE.</b>	<b>505855</b>	<b>1</b>	
1	GRID ADDITIONAL TVS INCLINE LOG DECK	505854-1	3	
2	BOLT M8x130-8.8-Fe/Zn5 PN-85/M-82101	F81002-50	24	
3	NUT,M8-8-B,HEX,NYLON LOCK ZINC	F81032-2	24	
4	WASHER, 8.4 FLAT,ZINC	F81054-1	48	

### 6.3 Limit Switch Assembly

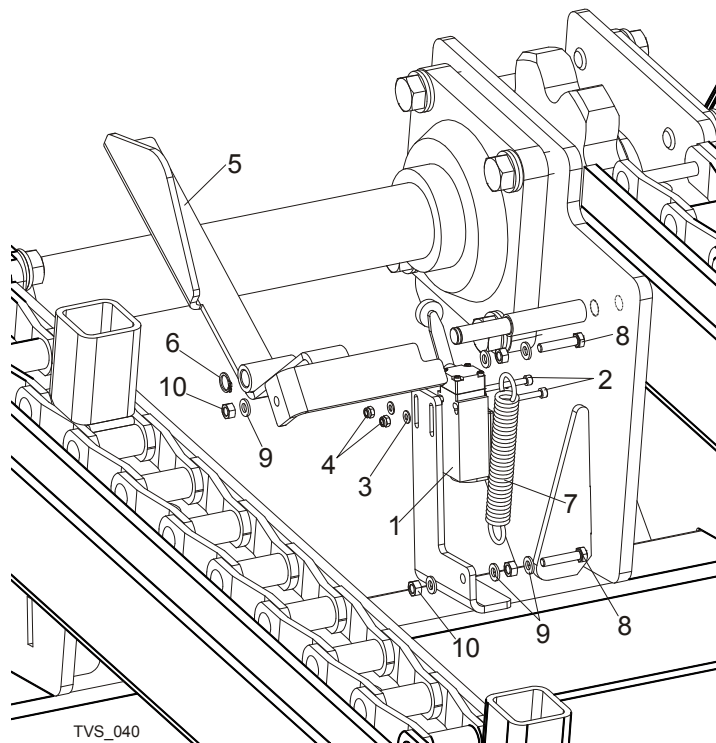

REF	DESCRIPTION (◆ Indicates Parts Available In Assemblies Only)	PART #	QTY.
1	LIMIT SWITCH, GLCB01A2B	086469	1
2	SCREW, M4X35-8.8 HEX SOCKET HEAD CAP ZINC	F81011-34	2
3	WASHER, 4.3 FLAT ZINC	F81051-2	2
4	NUT, M4-B HEX NYLON LOCK ZINC	F81029-1	2
5	ARM, TVS LIMIT SWITCH ACTIVATOR - COMPLETE	098474-1	1
6	RING, Z12 OUTSIDE RETAINING	F81090-14	1
7	SPRING, FI 1.9 X FI 14.2 X 104	091865	1
8	BOLT, M6X30 5.8 HEX HEAD FULL THREAD	F81001-13	2
9	WASHER, 6.4 FLAT ZINC	F81053-1	6
10	NUT, M6-8 HEX ZINC	F81031-1	4

## 6.4 Drive Assembly

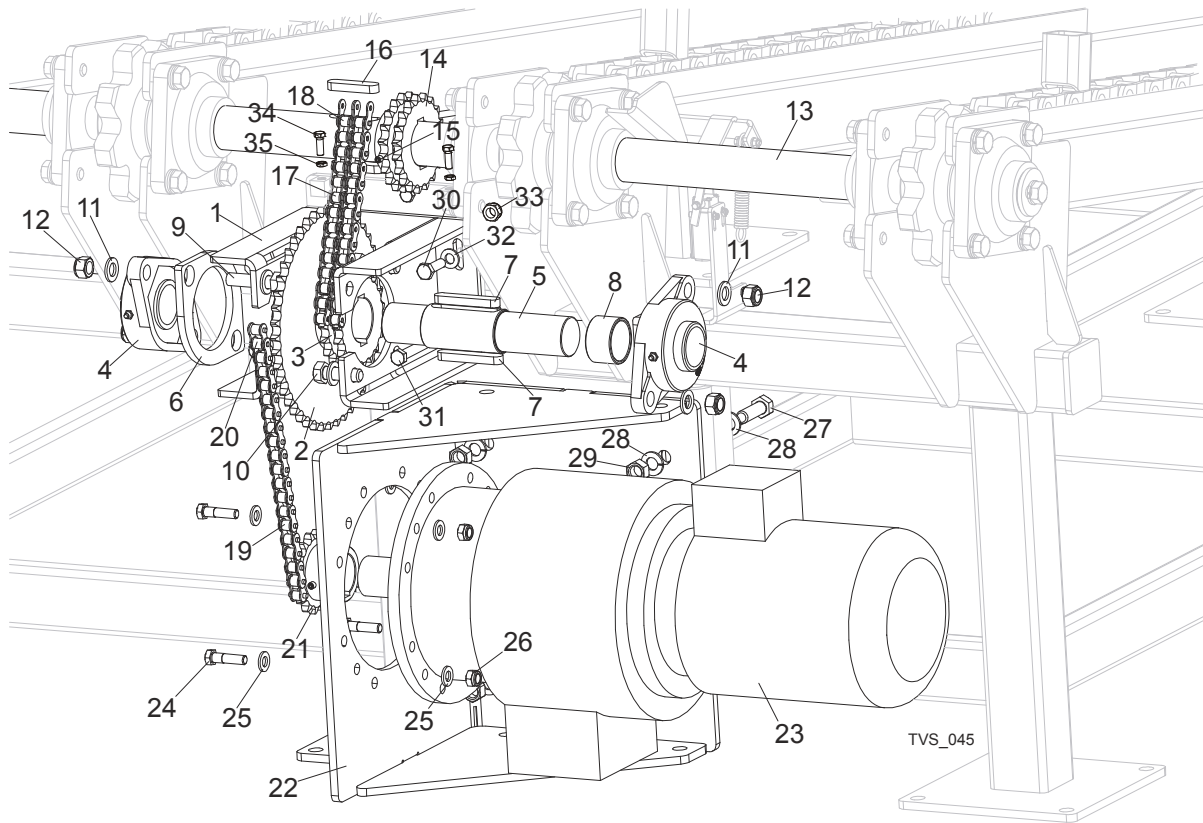

REF	DESCRIPTION (◆ Indicates Parts Available In Assemblies Only)	PART #	QTY.
	<b>GEAR ASSEMBLY, TVS INCLINE LOG DECK</b>	098424	1
1	BRACKET WELDMENT, TVS SPROCKET MOUNTING	098422-1	1
2	SPROCKET, 12B Z45 OXIDIZED	089894-1	1
3	SPROCKET, 12B Z19	098013-1	1
4	BEARING, UCFL 210 CX W/HOUSING	098824	2
5	SHAFT, INTERMEDIATE SPROCKET ZINC-PLATED	098419-1	1
6	PLATE, FL 210 BEARING SPACER	099106-1	1
7	KEY, A16X10X90 PARALLEL	099131	2
8	SPACER, TVS SPROCKET	098011-1	1
9	BOLT, M16	099647	2
10	BOLT, M16x50-8.8 HEX HEAD FULL THREAD ZINC	F81006-7	2
11	WASHER, 17 FLAT ZINC	F81058-1	8
12	NUT, M16-8 HEX NYLON LOCK ZINC	F81036-2	4
13	<b>SHAFT, TVS INCLINE LOG DECK MAIN</b>	098010	1
14	<b>SPROCKET, 12B Z19</b>	098013-1	1
15	<b>SCREW, M8X8-33H HEX SOCKET SET FLAT POINT ZINC</b>	F81014-1	4
16	<b>KEY, A16X10X70 PARALLEL</b>	098029	2
17	<b>CHAIN, 12B-2-41 (0.8 RM)</b>	099250	1
18	<b>LINK, 12B-1PZ CHAIN</b>	099249	1

19	CHAIN, 12B-1-65 (1.25 RM)	099248	1	
20	LINK, 12B-1PZ CHAIN	090713	1	
21	SPROCKET, 12B Z16 OXIDIZED	090303-1	1	
22	BRACKET WELDMENT, DECK MOTOR MOUNT	089897-1	1	
23	MOTOREDUCER, SBCM 180/112M-4/32	089892	1	
24	BOLT, M12X45-8.8 HEX HEAD ZINC	F81004-32	4	
25	WASHER, 13 FLAT ZINC	F81056-1	8	
26	NUT, M12-8 HEX NYLON LOCK ZINC	F81034-2	4	
27	BOLT, M16X50-8.8 HEX HEAD FULL THREAD ZINC	F81006-7	4	
28	WASHER, 17 FLAT ZINC	F81058-1	8	
29	NUT, M16-5.8 HEX ZINC	F81036-1	4	
30	BOLT, M12X40-8.8 HEX HEAD FULL THREAD ZINC	F81004-4	2	
31	BOLT, M12X120 8.8 HEX HEAD ZINC	F81004-38	2	
32	WASHER, 13 FLAT ZINC	F81056-1	8	
33	NUT, M12-8-B HEX ZINC	F81034-1	4	
34	BOLT, M10X50MM,HEX HEAD FULL THRD ZINC	F81003-4	2	
35	NUT, M10-8-B-FE	F81033-3		



## 6.5 Chain Guards

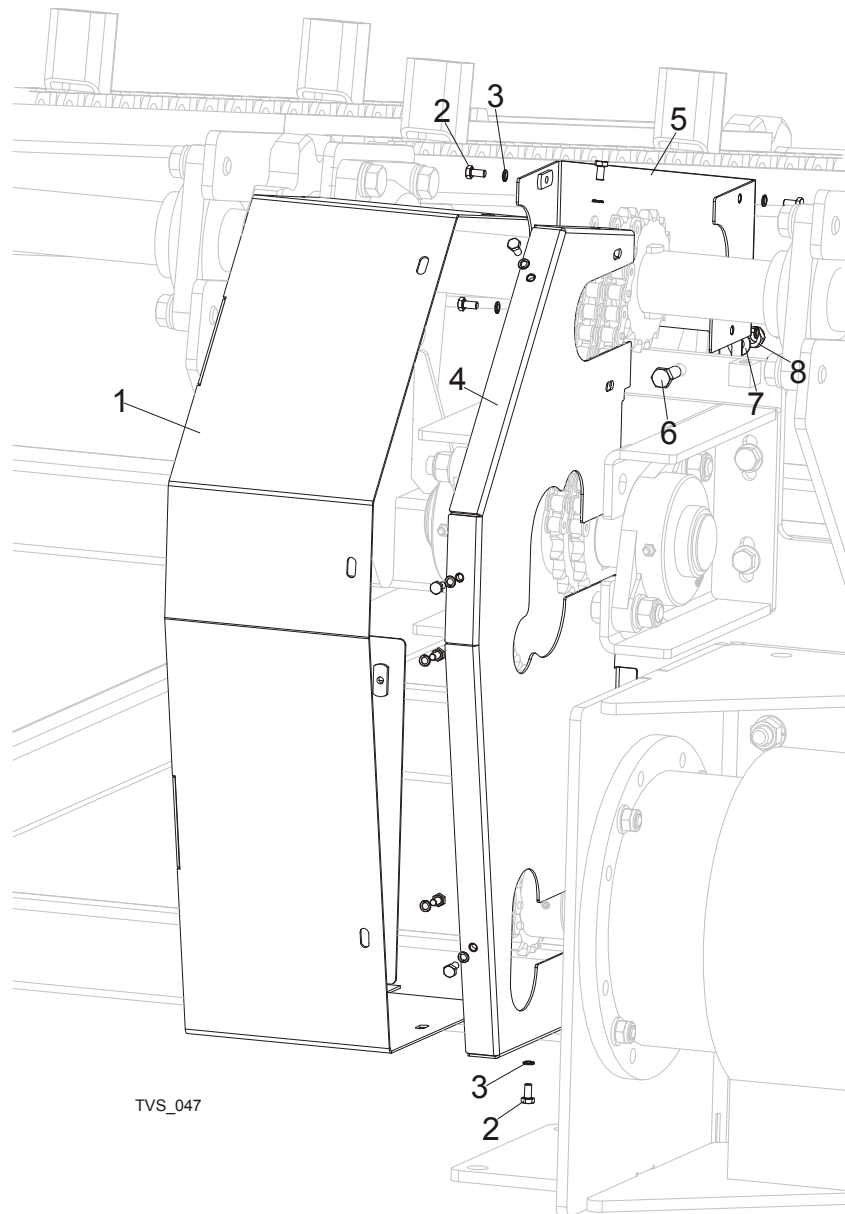

REF	DESCRIPTION (◆ Indicates Parts Available In Assemblies Only)	PART #	QTY.
1	GUARD, TVS ILD GEAR - MAIN	098467-1	1
2	BOLT, M6X12-8.8 HEX HEAD FULL THREAD ZINC	F81001-7	11
3	WASHER, Z 6.1 SPLIT LOCK ZINC	F81053-3	11
4	GUARD, TVS ILD GEAR - SIDE	098470-1	1
5	GUARD, TVS REAR	098469-1	1
6	BOLT, M10X30-5.8 HEX HEAD FULL THREAD ZINC	F81003-2	1
7	WASHER, 10.5 FLAT ZINC	F81055-1	1
8	NUT, M10-8-B HEX NYLON LOCK ZINC	F81033-1	1

## 6.6 Decals

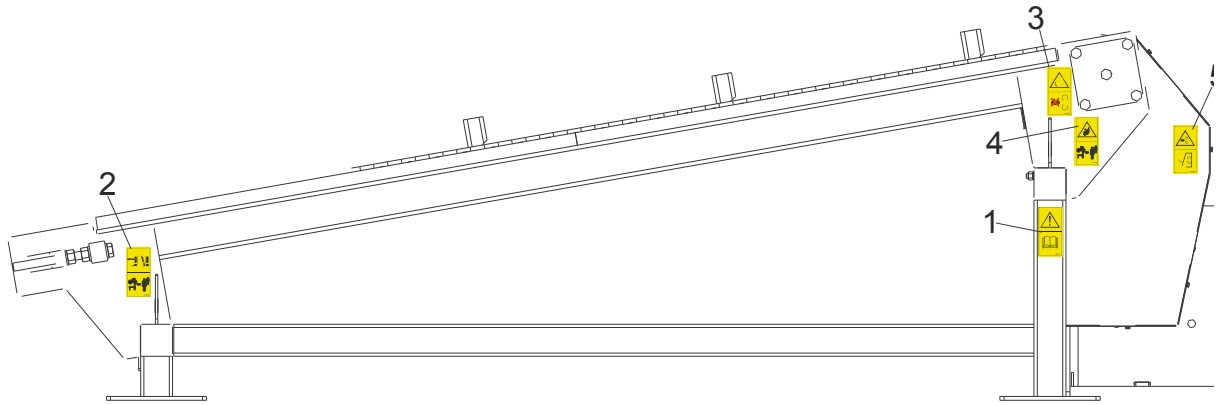

TVS\_048

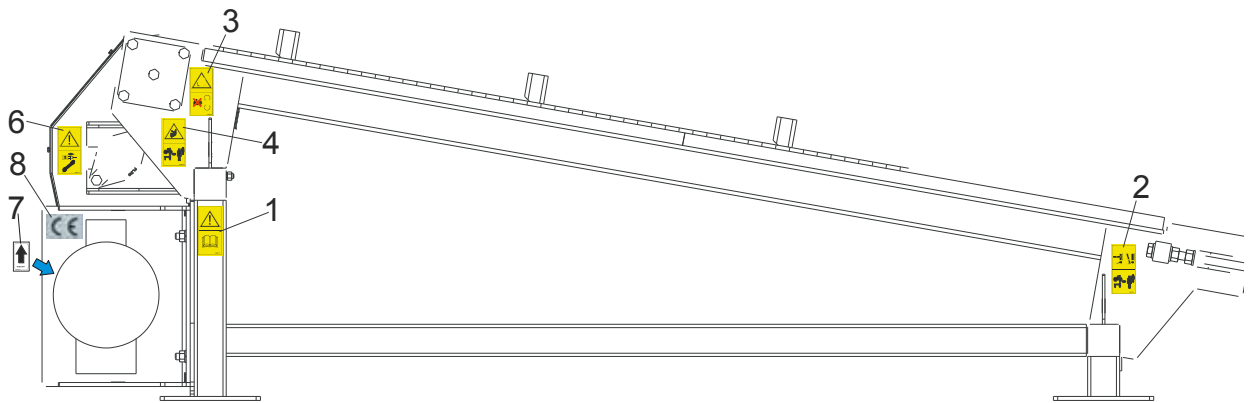

REF	DESCRIPTION (◆ Indicates Parts Available In Assemblies Only)	PART #	QTY.
	<b>DECALS KIT, PICTOGRAMS, INCLINE LOG DECK</b>	099579	1
1	Decal, read operator's manual (pictogram)	096317	2
2	Decal, keep away warning (pictogram)	096314	2
3	Decal, gear danger (pictogram)	099540	2
4	Decay, keep away warning (pictogram)	099221	2
5	Decal, close all guards and covers before starting the machine	099220	1
6	Decal, disconnect and lock out power supply before servicing (pictogram)	098177	1
7	Decal, 1400 RPM Motor Direction	S20097H	1
8	<b>DECAL, CE - CERTIFIED SAWMILL</b>	P85070	1

## SECTION 7 CROSS TRANSFER DECK

### 7.1 Front Module & Chains

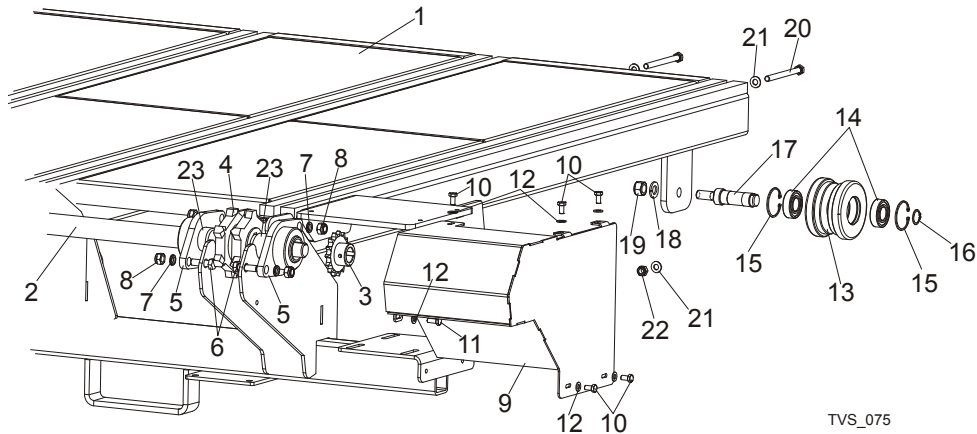

REF	DESCRIPTION (◆ Indicates Parts Available In Assemblies Only)	PART #	QTY.
	<b>COMPLETE FRONT MODULE</b>	099556	1
1	FRAME WELDMENT, CTD FRONT	097899-1	1
2	SHAFT, CTD DRIVE	097893	1
3	SPROCKET, 10B Z 15 INCLINE CONVEYOR	095162	1
4	SPROCKET, 16B 20Z	097657	4
5	BEARING, FYTB 40 KG	097898	8
6	BOLT, SPROCKET MOUNTING	091744	16
7	WASHER, 17 FLAT ZINC	F81058-1	16
8	NUT, M16 HEX NYLON ZINC LOCK	F81036-2	16
9	COVER, CTD CHAIN	097903-1	1
10	BOLT, M8x16-8.8 HEX HEAD ZINC	F81002-20	5
11	BOLT, M8X20-8.8-B HEX HEAD FULL THREAD ZINC	F81002-4	1
12	WASHER, 8.4 FLAT, ZINC	F81054-1	6
	WHEEL, CTD COMPLETE	098492	4
13	TENSIONER, CTD CHAIN	098493	1
14	BEARING, SKF 6205-2RS ROLLER	087353	2
15	RING, W52 INSIDE RETAINING	F81090-6	2
16	RING, 25Z OUTSIDE RETAINING	F81090-22	1
17	SHAFT, CTD CHAIN TENSIONER	098494	1
18	WASHER, 16.3 SPLIT LOCK ZINC	F81058-2	4
19	NUT, M16-8 HEX NYLON ZINC LOCK	F81036-2	4
20	BOLT, M10x125-8.8 HEX HEAD ZINC	F81003-18	6
21	WASHER, 10.5 FLAT ZINC	F81055-1	12
22	NUT, M10-8-B HEX NYLON ZINC LOCK	F81033-1	6
23	BUSHING, FI 40 x FI 48x14 SPACER	099958-1	8
	<b>CHAIN, SLPCTD3.6 ZINC-PLATED</b>	099310	4
	<b>CHAIN, SLPCTD5.4</b>	099571	4
	<b>CHAIN, CTC7.2</b>	099572	4

**7.2 Central Module**

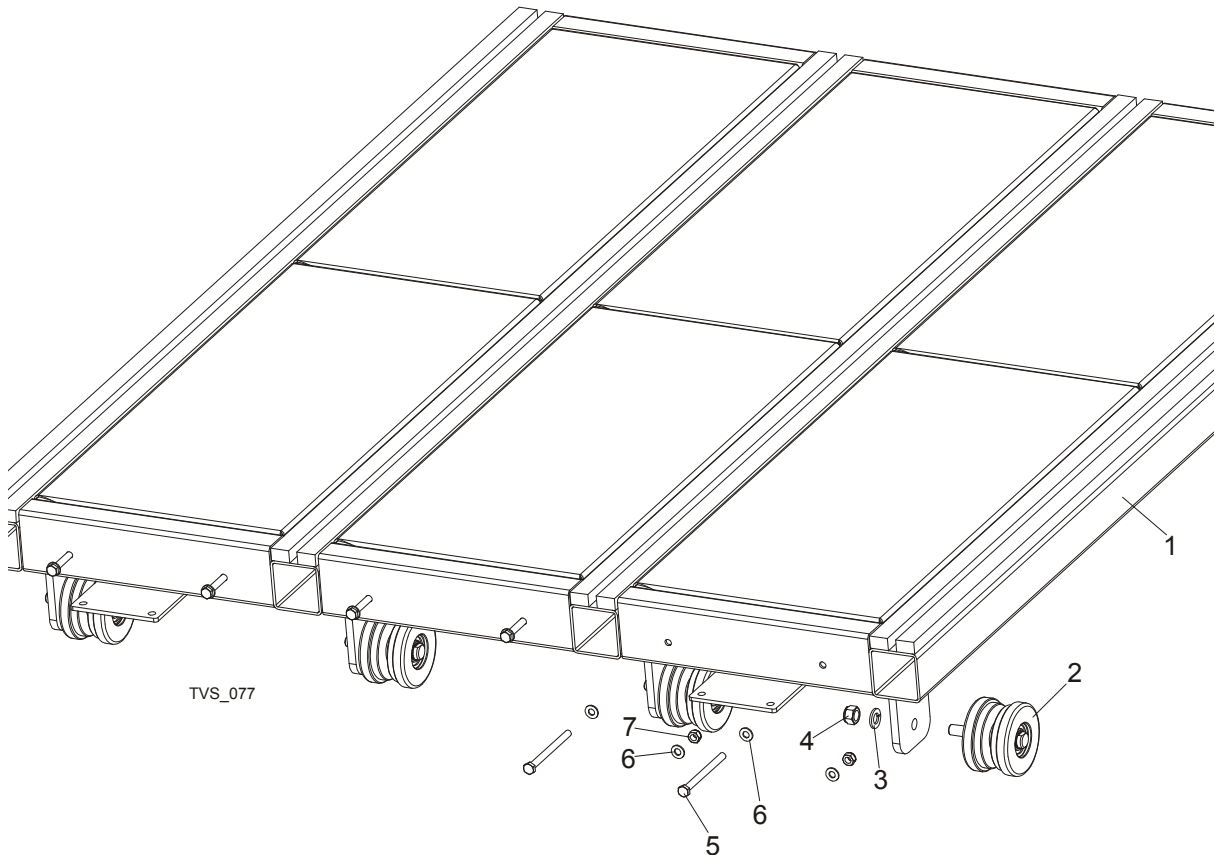

REF	DESCRIPTION (◆ Indicates Parts Available In Assemblies Only)	PART #	QTY.
	<b>COMPLETE CENTRAL MODULE</b>	099557	1/2 <sup>1</sup>
1	MODULE, CTD CENTRAL PAINTED	098125-1	1
2	WHEEL, CTD COMPLETE	098492	4
3	WASHER, 16.3 SPLIT LOCK ZINC	F81058-2	4
4	NUT, M16-8 HEX NYLON ZINC LOCK	F81036-2	4
5	BOLT, M10x125-8.8 HEX HEAD ZINC	F81003-18	6
6	WASHER, 10.5 FLAT ZINC	F81055-1	12
7	NUT, M10-8-B HEX NYLON ZINC LOCK	F81033-1	6

<sup>1</sup> Used on CTD5.4 - 1 piece and on CTD7.2 - 2 pieces.

7.3 Rear Module

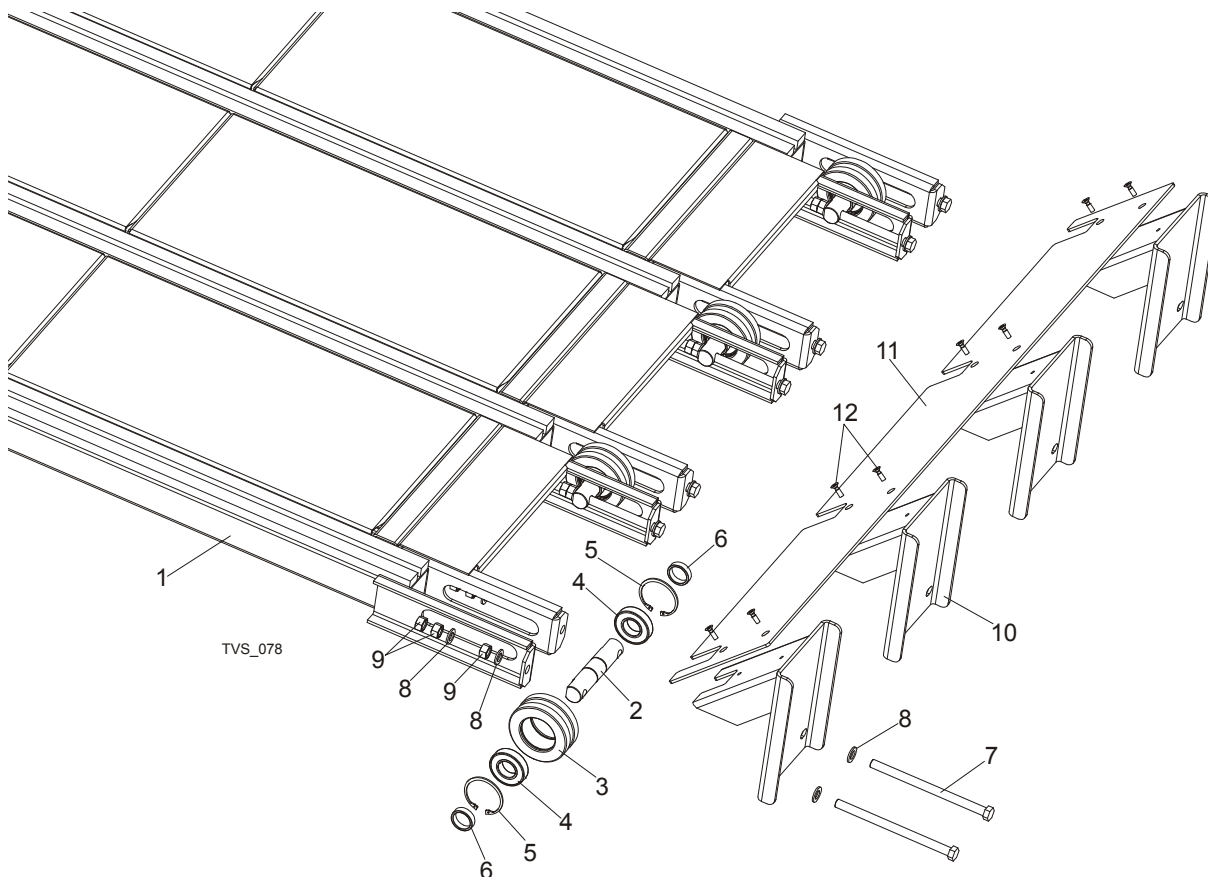

REF	DESCRIPTION (◆ Indicates Parts Available In Assemblies Only)	PART #	QTY.
	<b>COMPLETE REAR MODULE</b>	099558	1
1	FRAME WELDMENT, CTD REAR PTD	097900-1	1
	COMPLETE CHAIN TENSION WHEEL	097655	4
2	SHAFT, CHAIN TENSION WHEEL	096207-1	1
3	WHEEL, TVS CHAIN TENSION	096208-1	1
4	BEARING, 6207-2RS, C3, 35X72X17	014811	2
5	RING, W72 INSIDE RETAINING	F81090-4	2
6	BUSHING, FI 36x FI 44x22 SPACER ZINC	099959-1	8
7	BOLT, M16X240-8.8-A2 FULL THREAD	F81006-29	8
8	WASHER, 17 FLAT ZINC	F81058-1	24
9	NUT, M16-5.8 HEX ZINC	F81036-1	24
	<b>BUMPER ASSEMBLY</b>	099560-1	1
10	BRACKET, BUMPER MOUNTING	098223-1	4
11	PLATE, CTD BUMPER	098496-1	1
12	SCREW, M8X25 CROSS RECESSED COUNTERSUNK HEAD	F81002-51	8

**7.4 Cross Transfer Deck Drive**

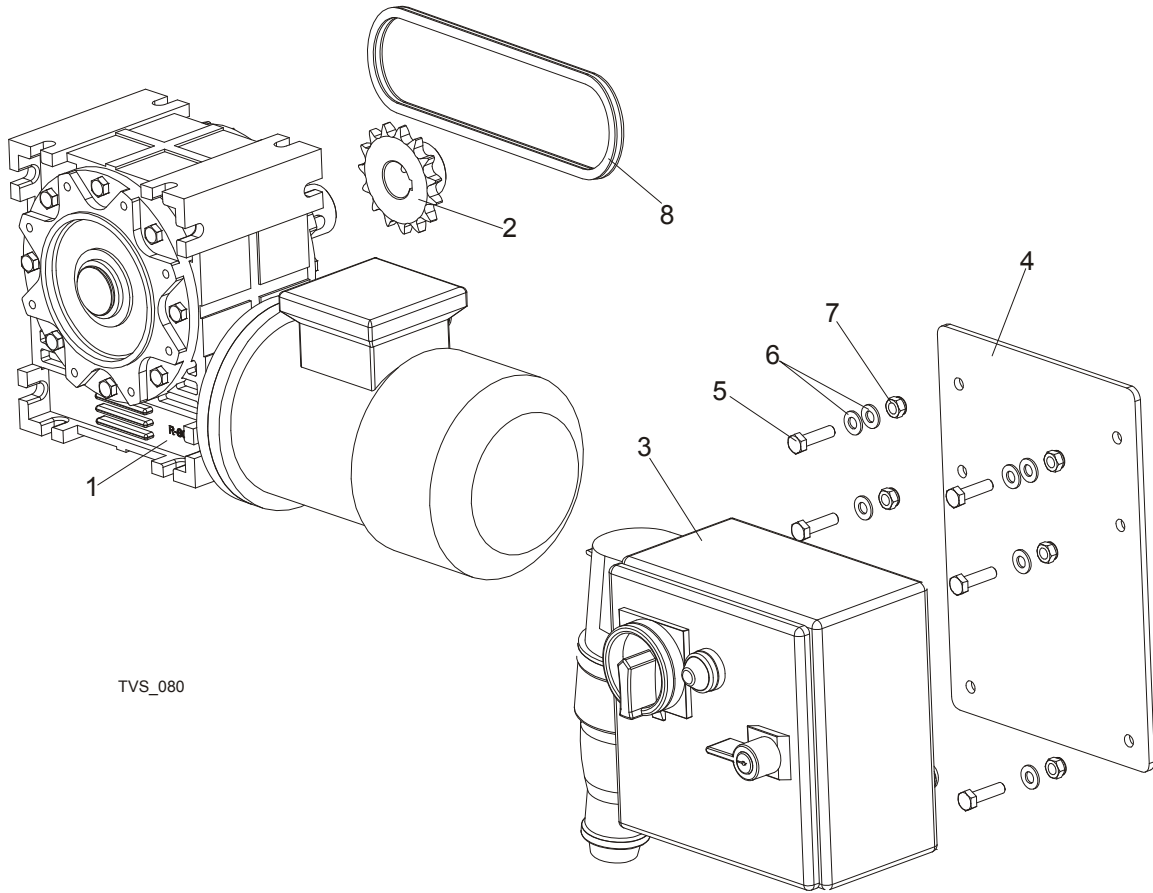

TVS\_080

REF	DESCRIPTION (◆ Indicates Parts Available In Assemblies Only)	PART #	QTY.
	<b>MOTOR KIT</b>	099559	1
1	MOTOREDUCER, MR-80/64-1.1-1400/K3/V6	098663	1
2	SPROCKET, 10B Z 15 INCLINE CONVEYOR	095162	1
3	BOX, CTD ELECTRIC	098826	1
4	PANEL, CTD ELECTRIC BOX	099550-1	1
5	BOLT, M8X30-5.8 HEX HEAD FULL THREAD ZINC	F81002-2	6
6	WASHER, 8.4 FLAT ZINC	F81054-1	8
7	NUT, M8-8-B HEX NYLON ZINC LOCK	F81032-2	6
8	CHAIN, 10B-48PZ	099781	1

### 7.5 Leg Kits

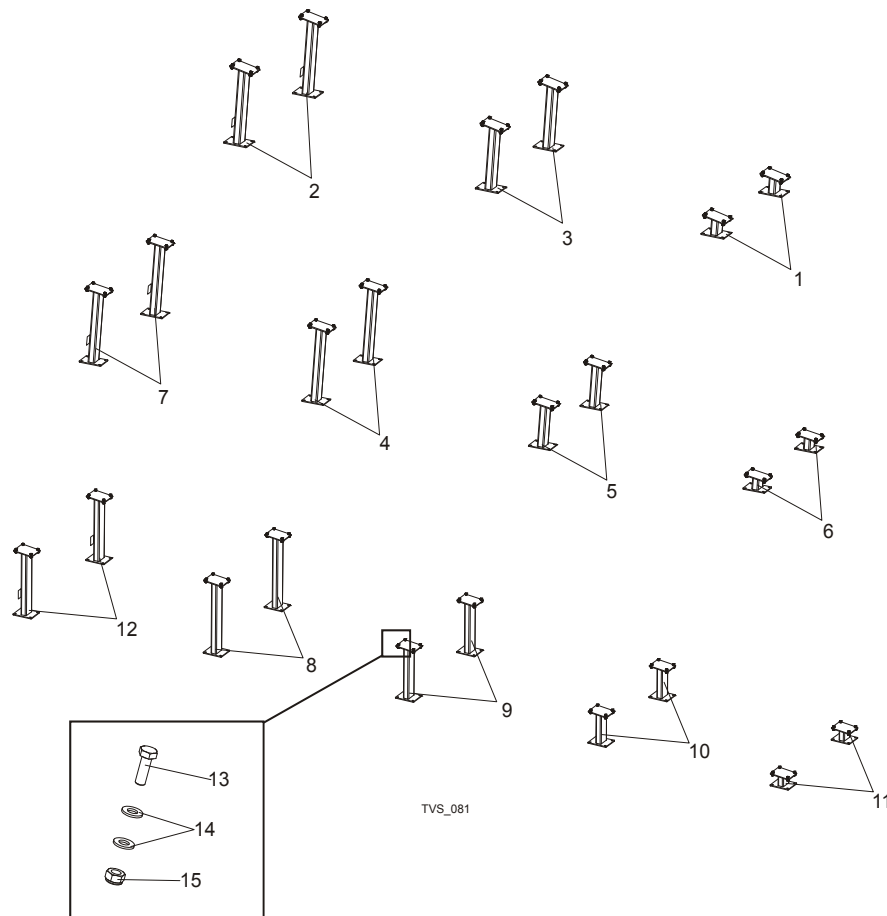

REF	DESCRIPTION (◆ Indicates Parts Available In Assemblies Only)	PART #	QTY.
	<b>LEG KIT, CTD SHORT</b>	099554	1
1	LEG, 7.6M REAR PTD	099279-1	2
2	LEG, FRONT PTD	099415-1	2
3	LEG, REAR PTD	099416-1	2
	<b>LEG KIT, CTD MEDIUM</b>	099568	1
4	LEG, CTD5.4 MIDDLE PTD (1)	099573-1	2
5	LEG, CTD5.4 MIDDLE PTD (2)	099574-1	2
6	LEG, CTD5.4 REAR PTD	099575-1	2
7	LEG, CTD5.4 FRONT PTD	099576-1	2
	<b>LEG KIT, CTD LONG</b>	099553	1
8	LEG, CTD7.2 MIDDLE PTD (1)	099277-1	2
9	LEG, CTD7.2 MIDDLE PTD (2)	099278-1	2
10	LEG, CTD7.2 MIDDLE PTD (3)	099562-1	2
11	LEG, CTD7.2 REAR PTD	099564-1	2
12	LEG, CTD7.2 FRONT PTD	099566-1	2
13	<b>BOLT, M10x30-5.8 HEX HEAD FULL THREAD ZINC</b>	F81003-2	24/32/40
14	<b>WASHER, 10.5 FLAT ZINC</b>	F81055-1	48/64/80
15	<b>NUT, M10-8-B HEX NYLON ZINC LOCK</b>	F81033-1	24/32/40

**7.6 Slabs Table**

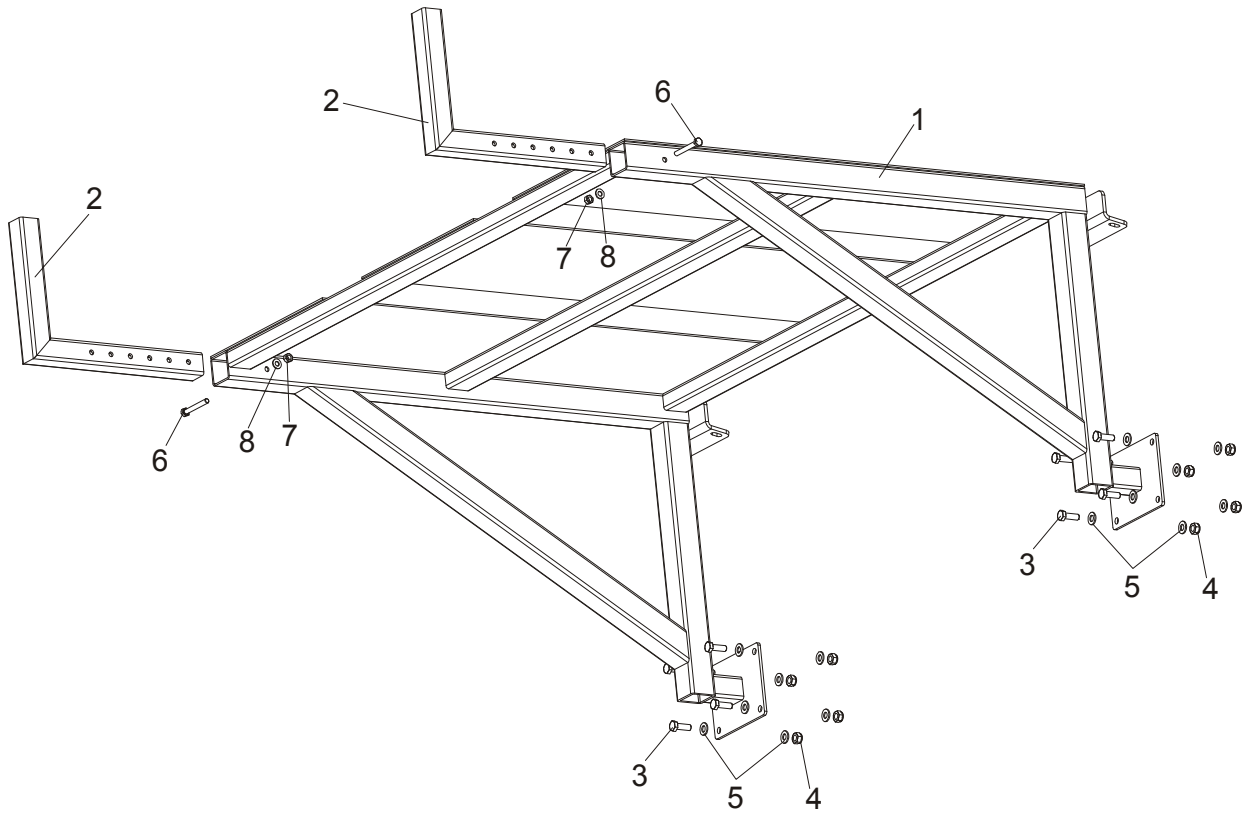

REF	DESCRIPTION (◆ Indicates Parts Available In Assemblies Only)	PART #	QTY.
1	TABLE, SLPCTD HIGH	100517-1	1
2	ARM, TABLE LOCK	100531-1	2
3	BOLT, M10X30-5.8 HEX HEAD FULL THREAD	F81003-2	8
4	NUT, M10-8-B NYLON HEX ZINC LOCK	F81033-1	16
5	WASHER, 10.5 FLAT ZINC	F81055-1	8
6	BOLT, M8X65 8.8 HEX HEAD ZINC	F81002-9	2
7	NUT, M8 HEXAGON, GRADE 5.8 FREE ZINC	F81032-1	2
8	WASHER, 8.4 FLAT ZINC	F81054-1	2



7.7 Decals

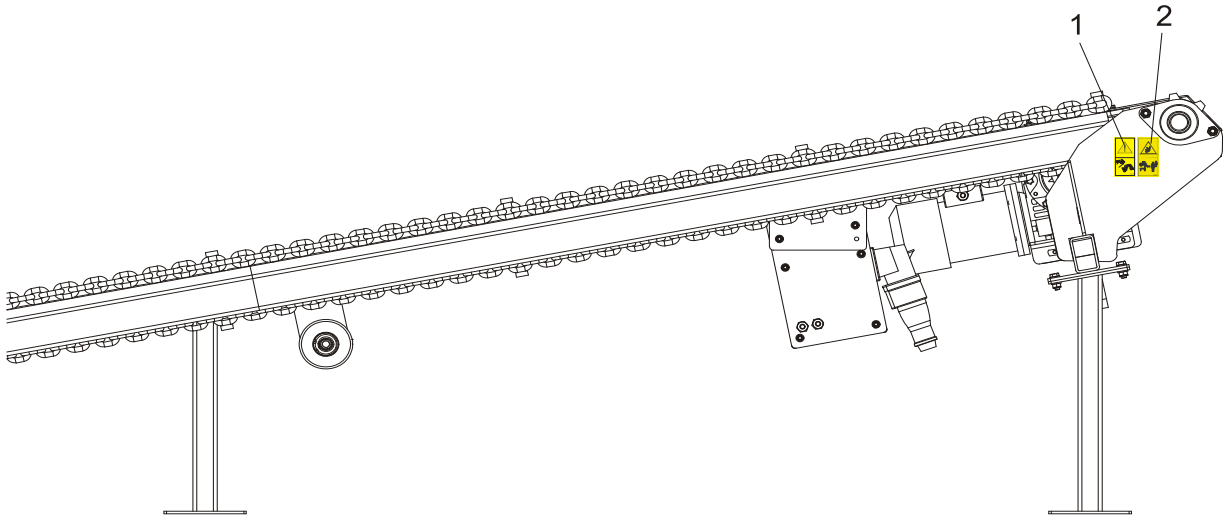
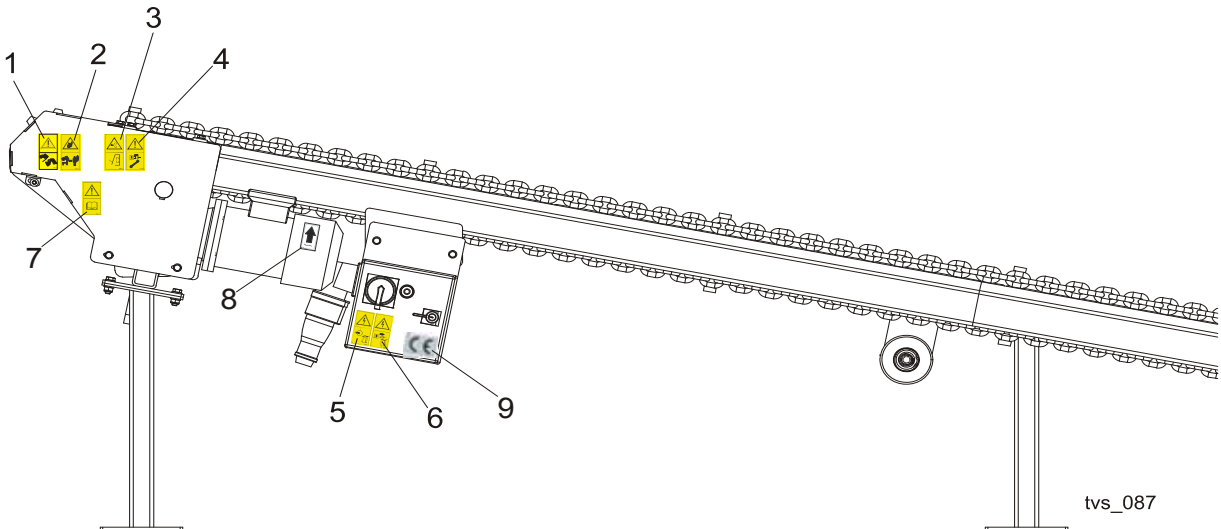

REF	DESCRIPTION (◆ Indicates Parts Available In Assemblies Only)	PART #	QTY.
	<b>DECALS KIT, PICTOGRAMS, CROSS TRANSFER DECK</b>	099835	1
1	Decal, look out for the falling slabs (pictogram)	099780	2
2	Decal, keep away warning (pictogram)	099221	2
3	Decal, close all guards and covers before starting the machine	099220	1
4	Decal, disconnect and lock out power supply before servicing (pictogram)	098177	1
5	Decal, high voltage inside the electric box (pictogram)	096316	1
6	Decal, remove the plug before opening the box (pictogram)	096319	1
7	Decal, read operator's manual (pictogram)	096317	1
8	Decal, 1400 RPM motor direction	S20097H	1
9	<b>DECAL, CE - CERTIFIED SAWMILL</b>	P85070	1