

Wood-Mizer®

Twin Vertical Saw

Parts Manual

TVSE11S
TVSE15S

rev.A2.00
rev.A2.00



Safety is our #1 concern! Read and understand all safety information and instructions before operating, setting up or maintaining this machine.

August 2007

Form #1004

Table of Contents

Section-Page

SECTION 1	GENERAL INFORMATION	1-1
1.1	How To Use The Parts List	1-1
1.2	Sample Assembly	1-1
SECTION 2	BLADE GUIDE ROLLERS & ARM	2-1
2.1	Blade Guide Assembly, Idle Side.....	2-1
2.2	Blade Guide Assembly, Drive Side.....	2-3
SECTION 3	BLADE WHEELS & TENSIONER	3-1
3.1	Blade Wheel Assembly, Drive Side	3-1
3.2	Blade Wheel Assembly, Idle Side.....	3-2
3.3	Blade Tensioner Assembly.....	3-3
SECTION 4	SAW HEAD	4-1
4.1	Middle Throat Screw	4-1
4.2	Water Lube Assembly (LMS)	4-2
4.3	Saw Head Decals	4-4
4.4	Blade Housing Cover	4-5
4.5	Saw Head Width Manual Adjustment Assembly	4-7
4.6	Saw Head Width Automatic Adjustment Assembly (Optional).....	4-9
4.7	Saw Head Width Indicator	4-11
4.8	Saw Head Slide Brackets.....	4-12
4.9	Hold-down roller	4-13
4.10	Blade Drive Motor.....	4-15
4.11	Saw Head Support Rollers.....	4-16
4.12	Electric Box	4-17
4.13	Laser Assembly (Optional).....	4-18
SECTION 5	INFEED & OUTFEED TABLES	5-1
5.1	TVS Infeed	5-1
5.2	Infeed table chain tension wheel	5-5
5.3	Chain Drive Assembly, TVS.....	5-6
5.4	TVS Outfeed.....	5-8
5.5	Tables Decals.....	5-11
SECTION 6	INCLINE LOG DECK	6-1
6.1	Infeed Assembly	6-1
6.2	Limit Switch Assembly	6-3
6.3	Drive Assembly	6-4
6.4	Chain Guards	6-6
6.5	Decals	6-7
SECTION 7	CROSS TRANSFER DECK	7-1
7.1	Front Module & Chains.....	7-1
7.2	Central Module.....	7-2

Table of Contents

Section-Page

7.3	Rear Module	7-3
7.4	Cross Transfer Deck Drive	7-4
7.5	Leg Kits	7-5
7.6	Slabs Table	7-6
7.7	Decals	7-7

SECTION 1 GENERAL INFORMATION

1.1 How To Use The Parts List

- Use the index above to locate the assembly that contains the part you need.
- Go to the appropriate section and locate the part in the illustration.
- Use the number pointing to the part to locate the correct part number and description in the table.
- Parts shown indented under another part are included with that part.
- Parts marked with a diamond (◆) are only available in the assembly listed above the part.

See the sample table below. Sample Part #A01111 includes part F02222-2 and subassembly A03333. Subassembly A03333 includes part S04444-4 and subassembly K05555. The diamond (◆) indicates that S04444-4 is not available except in subassembly A03333. Subassembly K05555 includes parts M06666 and F07777-77. The diamond (◆) indicates M06666 is not available except in subassembly K05555.

1.2 Sample Assembly				
REF	DESCRIPTION (◆ Indicates Parts Available In Assemblies Only)	PART #	QTY.	
	Sample Assembly, Complete (Includes All Indented Parts Below)	A01111	1	
1	Sample Part	F02222-22	1	
	Sample Subassembly (Includes All Indented Parts Below)	A03333	1	
2	Sample Part (◆ Indicates Part Is Only Available With A03333)	S04444-4	1	◆
	Sample Subassembly (Includes All Indented Parts Below)	K05555	1	
3	Sample Part (◆ Indicates Part Is Only Available With K05555)	M06666	2	◆
4	Sample Part	F07777-77	1	

To Order Parts:

- From Europe call our European Headquarters and Manufacturing Facility in Kolo, Poland at **+48-63-2626000**. From the continental U.S., call our toll-free Parts hotline at **1-800-448-7881**. Have your customer number, vehicle identification number, and part numbers ready when you call.
- From other international locations, contact the Wood-Mizer distributor in your area for parts.

SECTION 2 BLADE GUIDE ROLLERS & ARM

2.1 Blade Guide Assembly, Idle Side

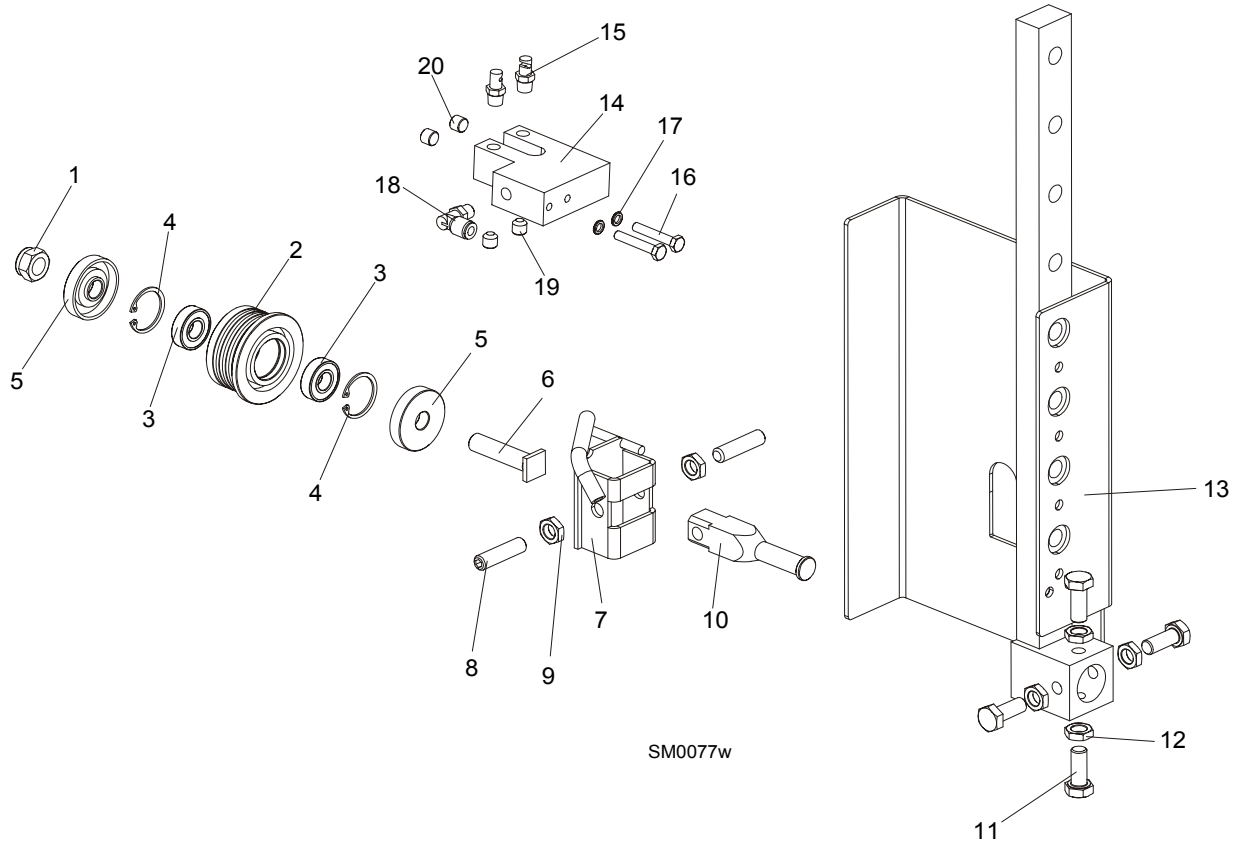

REF	DESCRIPTION (◆ Indicates Parts Available In Assemblies Only)	PART #	QTY.	
	ROLLER, BLADE GUIDE COMPLETE STANDARD	087887	1	
1	Nut, M12-8 Hex Nylon Zinc Lock	F81034-2	1	
2	Roller, Blade Guide Narrow	087889	1	◆
3	Bearing, 6001 2RSR FAG	087893	2	
4	Ring, W28 Inside Retaining	F81090-9	1	
5	Washer, Zinc-plated Spacer	087891-1	2	
6	SHAFT, BLADE GUIDE ROLLER ZINC-PLATED	087763-1	1	
7	BRACKET WELDMENT, IDLE SIDE BLADE GUIDE PAINTED	094681-1	1	
8	Screw, M10x1x40 DIN 913 A2-70 Set Stainless Steel	F81015-2	2	
9	Nut, M10x1-04-ST-A2 ISO 8675 Thin	F81033-10	2	
10	Shaft, Blade Guide Mount Zinc-plated	088255-1	1	
11	BOLT, M10x1x25 DIN 933	F81003-28	4	
12	NUT, M10x1-04-ST-A2 ISO 8675 THIN	F81033-10	4	
13	ROLLER GUIDE, TVS RIGHT-PTD	096131-1	1	
	ROLLER GUIDE, TVS LEFT-PTD	098608-1	1	
	LUBE SYSTEM, TVS	098583	2	

2**Blade Guide Rollers & Arm***Blade Guide Assembly, Idle Side*

14	BLOCK, NOZZLE MOUNTING ZINC-PLATED	097943-1	1	
15	NOZZLE, BLADE LUBE SPRAY	033479	2	
16	BOLT, M6x35 8.8 HEX HEAD ZINC	F81001-71	2	
17	WASHER, M6 SPLIT LOCK ZINC	F81053-3	2	
18	Fitting, 1/8MPTx1/4Tube,Elbow,Swivel	P09736	1	
19	Fitting, 1/8 NPT Socket Pipe Plug	P30127	2	
20	PLUG, M10x1 DIN 906 BN40 "BOSSARD"	F81015-3	2	

2.2 Blade Guide Assembly, Drive Side

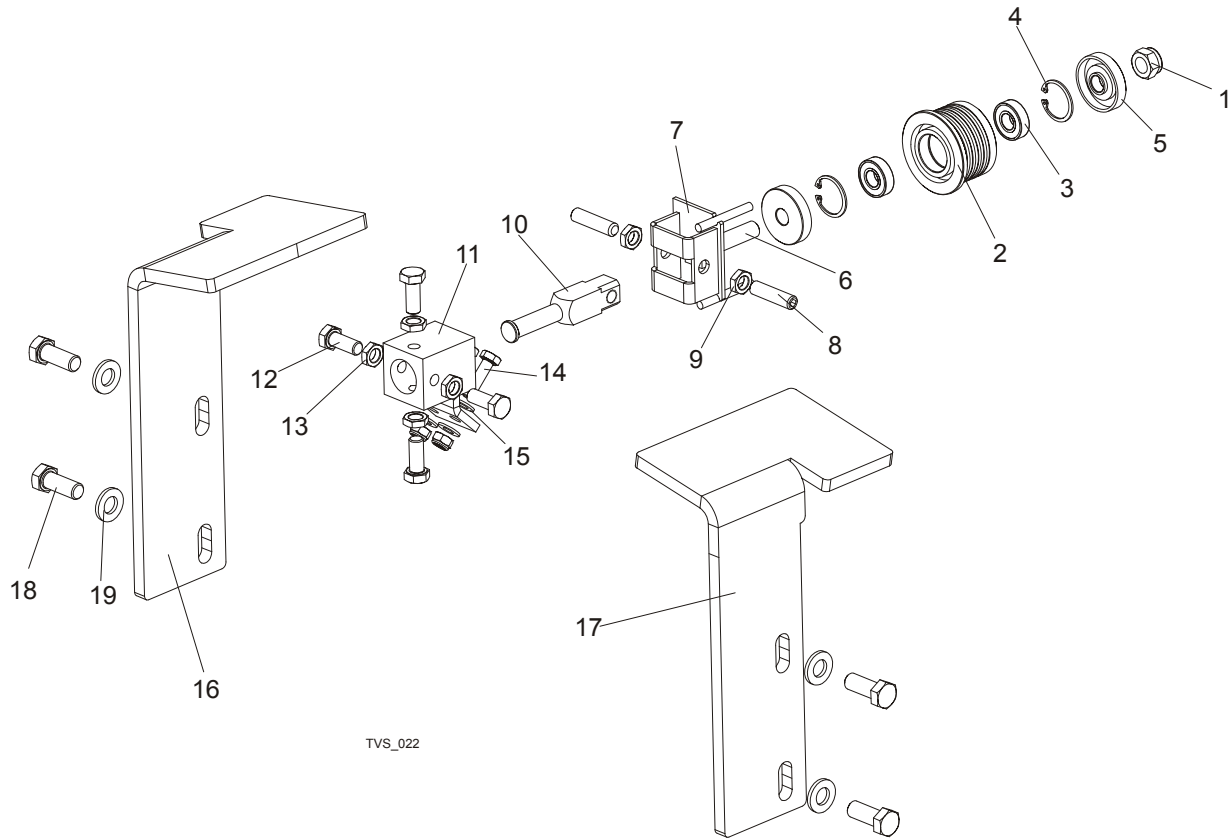

TVS_022

REF	DESCRIPTION (◆ Indicates Parts Available In Assemblies Only)	PART #	QTY.
	BLADE GUIDE ASSEMBLY, DRIVE SIDE	094682	1
	Roller, Blade Guide Complete Standard	087887	1
1	Nut, M12-8 Hex Nylon Zinc Lock	F81034-2	1
2	Roller, Blade Guide Narrow	087889	1
3	Bearing, 6001 2RSR FAG	087893	2
4	Ring, W28 Inside Retaining	F81090-9	1
5	Washer, Zinc-plated Spacer	087891-1	2
6	Shaft, Blade Guide Roller Zinc-plated	087763-1	1
7	Bracket Weldment, Blade Guide Painted	094679-1	1
	Screw Kit, Blade Guide Adjustment w/Nuts (for two blade guide assemblies)	K09942	1
8	Screw, M10x1x40 DIN 913 A2-70 Set Stainless Steel	F81015-2	2
9	Nut, M10x1-04-ST-A2 ISO 8675 Thin	F81033-10	2
10	Shaft, Blade Guide Mount Zinc-plated	088255-1	1
11	BLOCK WELDMENT, PAINTED BLADE GUIDE MOUNT	088292-1	3
12	BOLT, M10X1X25 DIN 933 STAINLESS STEEL	F81003-28	1
13	NUT, M10x1-04-ST-A2 ISO 8675 THIN	F81033-10	4
14	BOLT, M8X20MM, HEX HEAD,GR 5.8 ZINC	F81002-4	2
15	WASHER, 8.2 SPLIT LOCK ZINC	F81054-4	2
16	COVER, DRIVE SIDE ROLLER RIGHT	097660-1	1

2**Blade Guide Rollers & Arm***Blade Guide Assembly, Drive Side*

17	COVER, DRIVE SIDE ROLLER LEFT	098435-1	1	
18	BOLT M12x30-8.8	F81004-22	4	
19	WASHER, M12 , FLAT, ZINC	F81056-1	4	

SECTION 3 BLADE WHEELS & TENSIONER

3.1 Blade Wheel Assembly, Drive Side

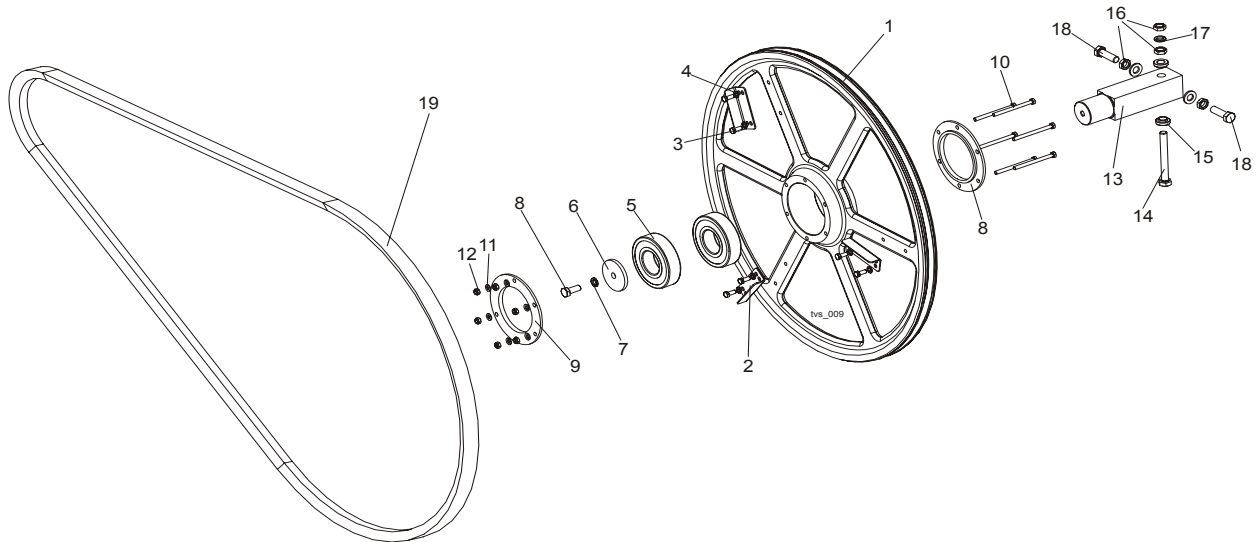

REF	DESCRIPTION (◆ Indicates Parts Available In Assemblies Only)	PART #	QTY.
	DRIVE WHEEL, TVS, COMPLETE	096109	1
1	Drive Blade Wheel	096105-1	1
2	Wing, TVS	096363-1	3
3	Bolt, M6 x 16 8.8 Fe/Zn5 PN-M/82105	F81001-15	6
4	Washer, M6 Split Lock Zinc	F81053-3	6
5	Bearing 6309 2RSR	096107	2
6	Washer, Idle Blade Wheel Retaining	088957-1	1
7	Washer, M10 Split Lock zinc	F81055-2	1
8	Bolt, M10X25 8.8 Hex Head Full Thread	F81003-31	1
9	Ring, Bearing Mounting	096108-1	2
10	Bolt, M6x80 Fe/Zn5	F81001-61	6
11	Washer, M6, Flat, zinc	F81053-1	6
12	Nut, M6, Hex, Nylon Lock zinc	F81031-2	6
13	AXLE, DRIVE WHEEL, TVS	096110	1
14	BOLT, M12X1.25X100-8.8 HEX HEAD ZINC	F81004-41	1
15	SPACER, BLADE GUIDE	086769-1	2
16	NUT, M12X1.25 8.8 HEX ZINC THIN	F81034-5	3
17	WASHER, M12 SPLIT LOCK ZINC	F81056-2	1
18	BOLT, M12X1.25X40 HEX HEAD	F81004-42	2
19	IDLE SIDE BELT 5VX1080	033391	1

3.2 Blade Wheel Assembly, Idle Side

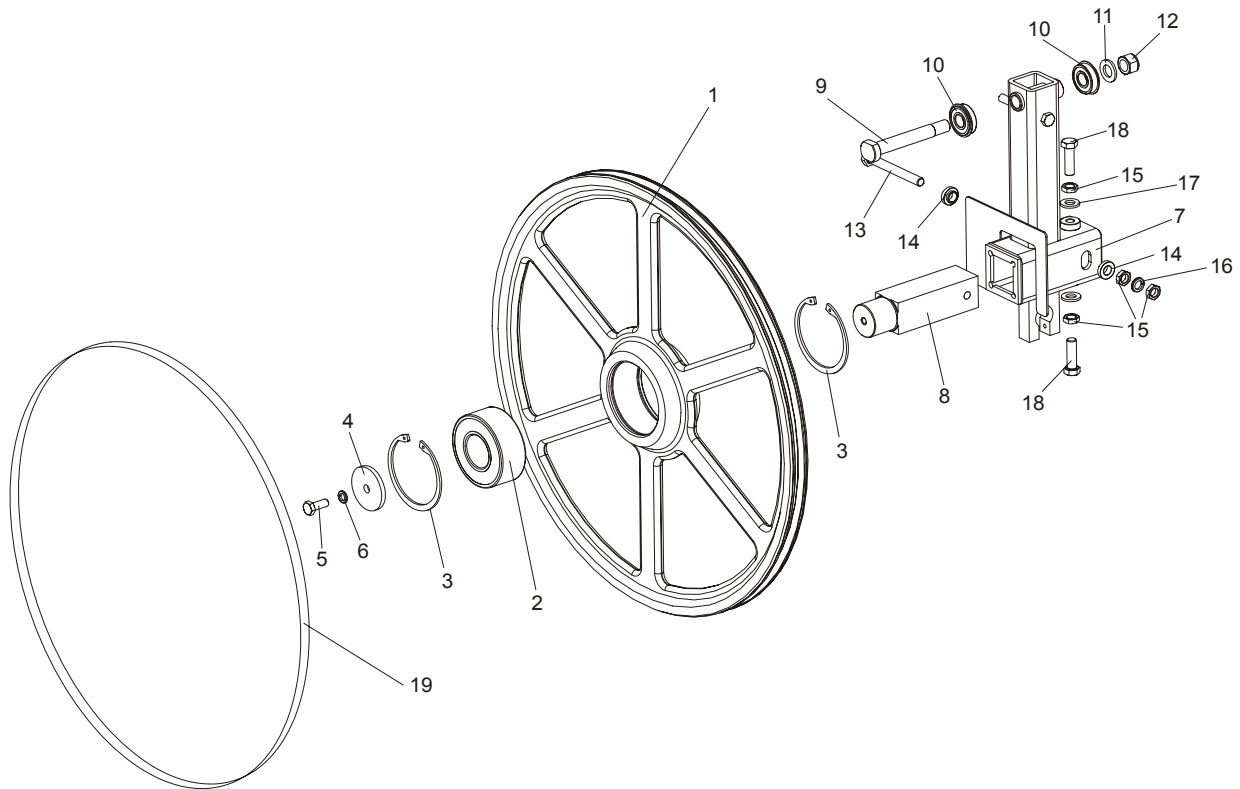

REF	DESCRIPTION (◆ Indicates Parts Available In Assemblies Only)	PART #	QTY.
	WHEEL ASSEMBLY, IDLE SIDE BLADE	088764	1
1	Wheel, Idle Side, ptd	090810-1	1
2	Bearing, 3309B.2RSR.TVH FAG	086428	1
3	Ring, W100 Inside Retaining	F81090-10	2
4	WASHER, BLADE WHEEL RETAINING ZINC-PLATED	088957	1
5	BOLT, M10X25 8.8 HEX HEAD FULL THREAD	F81003-31	1
6	WASHER, 10.2 SPLIT LOCK ZINC	F81055-2	1
7	ARM WELDMENT, RESAW & TVS IDLE SIDE BLADE WHEEL	098606-1	1
8	SHAFT, IDLE SIDE BLADE WHEEL	088474	1
9	BOLT, ARM BEARING MOUNT	086404	1
10	BEARING, 6203-2RS NR NSK W/SNAP RING	086395	2
11	WASHER, 17 FLAT ZINC	F81058-1	1
12	NUT, M16-8 HEX NYLON ZINC LOCK	F81036-2	1
13	BOLT, M12X1.25X100-8.8 HEX HEAD FULL THREAD ZINC	F81004-41	1
14	WASHER, FLANGED ZINC-PLATED	086769-1	2
15	NUT, M12X1.25 8.8 HEX THIN ZINC	F81034-5	4
16	Washer, Z12.2 Split Lock Zinc	F81056-2	1
17	WASHER, 13 FLAT ZINC	F81056-1	2
18	BOLT, M12X1.25X40-8.8 HEX HEAD FULL THREAD ZINC	F81004-42	2
19	BELT, B72.5	017922	1

3.3 Blade Tensioner Assembly

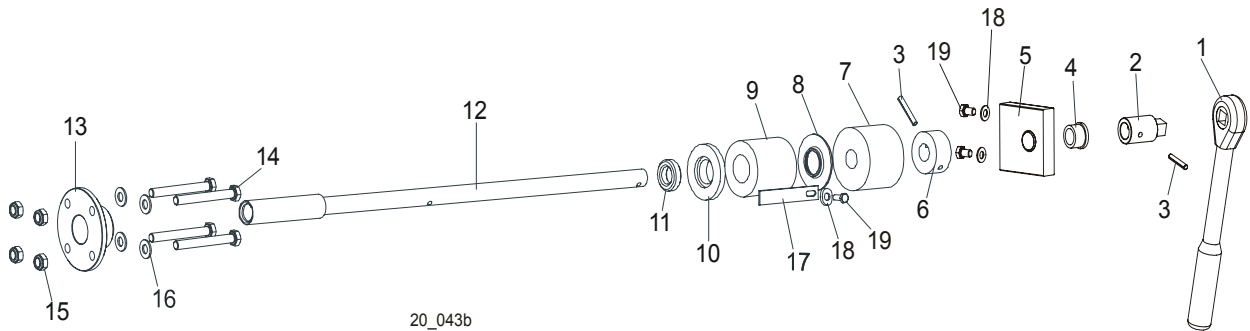

20_043b

REF	DESCRIPTION (◆ Indicates Parts Available In Assemblies Only)	PART#	QTY.
1	WRENCH, BLADE TENSION	091620	1
	BLADE TENSIONER ASSEMBLY	098725	1
2	End, LT20 Blade Tensioner Shaft	091606-1	1
3	Pin, 5 x 30 Zinc Roll	F81044-21	2
	Bracket, Tension Handle Mount w/Bushing	096729	1
4	Bushing GFM-1618-17(IGUS)	089589	1
5	Bracket, Painted	096730	1
6	Collar, Blade Tensioner	086712-1	1
7	Bushing, Rubber Stop	P12165	1
8	Guide, LT15 Tension Handle	014925	1
9	Spring, LT15 Rubber Blade Tensioner	014828	1
10	Washer, Rubber Spring Front	086674-1	1
11	Bearing, 51103 FLT Ball Thrust	086675	1
12	Shaft Weldment, Blade Tensioner Zinc-plated	098724-1	1
13	Nut, Blade Tensioner	086672-1	1
14	Bolt, M8x70 8.8 Hex Head Zinc	F81002-71	4
15	Nut, M8-8-B Hex Nylon Zinc Lock	F81032-2	4
16	Washer, 8.4 Zinc Flat	F81054-1	8
17	Indicator, LT15 Blade Tension Zinc-plated	086783-1	1
18	Washer, 6.4 Zinc Flat	F81053-1	1
19	Bolt, M6x16 8.8 Hex Head Full Thread Zinc	F81001-15	1

SECTION 4 SAW HEAD

4.1 Middle Throat Screw

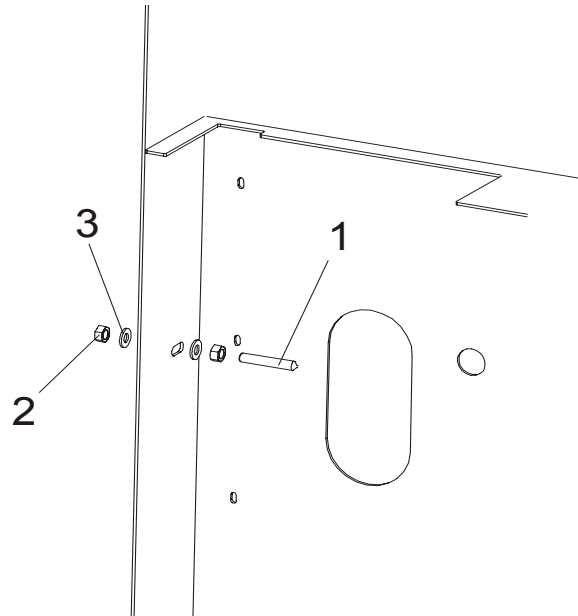

REF	DESCRIPTION (◆ Indicates Parts Available in Assemblies Only)	PART #	QTY.	
1	SCREW, M10X60-45H HEX SOCKET SET CONE POINT ZINC	F81003-87	1	
2	NUT, M10-8-B HEX ZINC	F81033-3	2	
3	WASHER, 10.5 FLAT ZINC	F81055-1	2	

4.2 Water Lube Assembly (LMS)

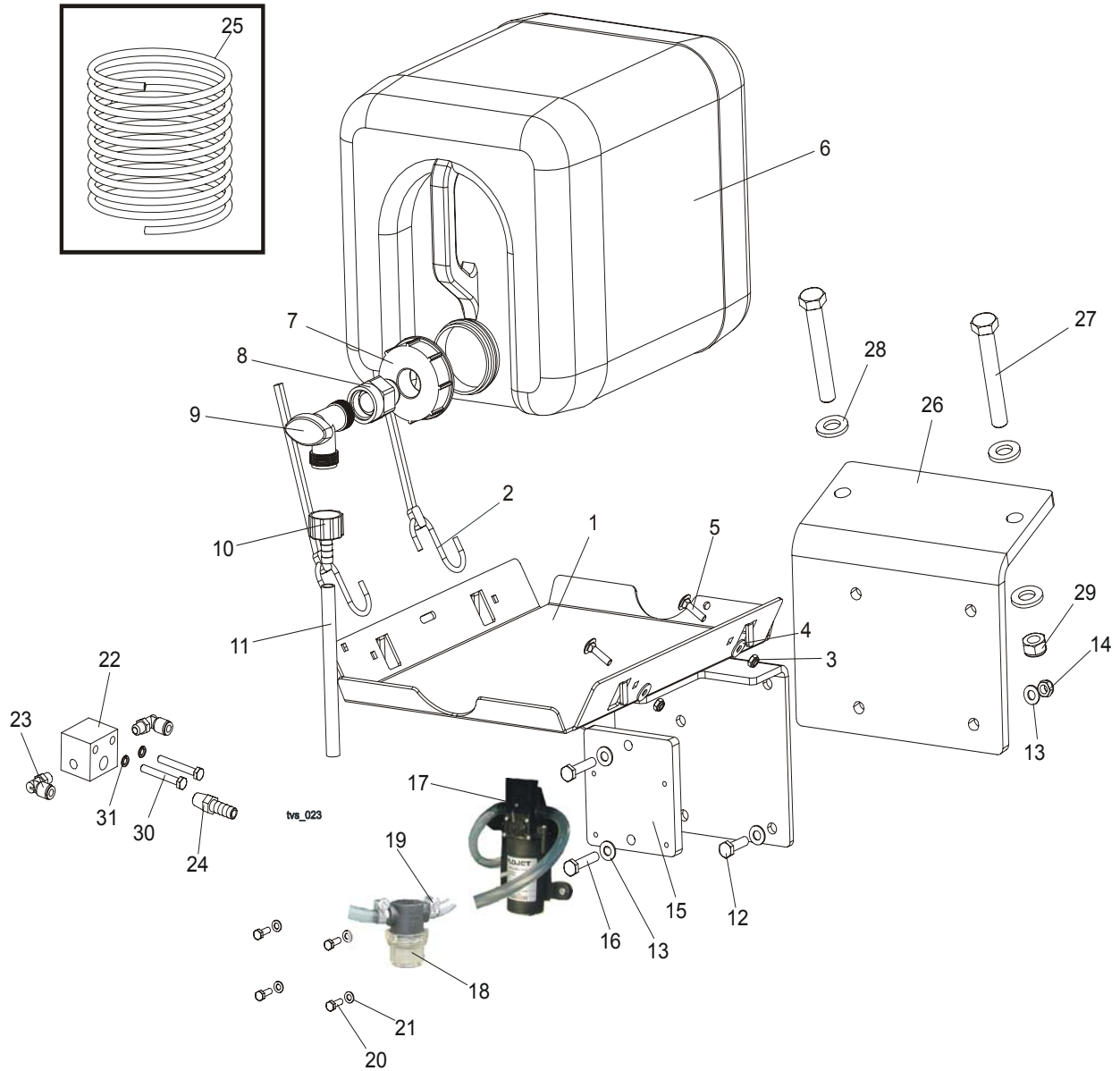

REF	DESCRIPTION (◆ Indicates Parts Available In Assemblies Only)	PART #	QTY.
	BOTTLE KIT, LT20 WATER LUBE	091036	1
1	TRAY WELDMENT, LT20 WATER LUBE	091033-1	1
2	STRAP, 20" RUBBER	P11668	2
3	NUT, M6-8-B HEX NYLON ZINC LOCK	F81031-2	2
4	WASHER, 6.5 ZINC FLAT	F81053-11	2
5	BOLT, M6X25-8.8 CARRIAGE HEAD ZINC	F81001-20	2
	BOTTLE ASSEMBLY, WATER LUBE	014642	1
6	Bottle, 19 l Water Lube	014637	1
7	Cap, Water Lube Bottle Buttress Thread	014773	1

4

Saw Head

Water Lube Assembly (LMS)

8	FITTING, 3/4FPT X 3/4MPT	014636	1	
9	FITTING, WATER LUBE SHUTOFF VALVE	014100	1	
10	FITTING, 5/8" NPT TO 3/8" HOSE BARB	014113	1	
11	TUBING, WATER LUBE	R01885	2.1 m	
12	BOLT, M8X30-8.8-B-HEX HEAD FULL THREAD ZINC	F81002-7	1	
13	WASHER, 8.4 ZINC FLAT	F81054-1	3	
14	NUT, M8-8-B Hex Nylon Zinc Lock	F81032-2	1	
15	BRACKET, LMS PUMP ZINC	098762-1	1	
16	BOLT, 8MM X 1.25 X 40MM HH ZINC	F81002-15	2	
17	PUMP ASSEMBLY, PRESSURE LUBE	033492	1	
	HEAD KIT, PRESSURE LUBE PUMP	033442	1	
	MOTOR KIT, PRESSURE LUBE PUMP 12V	033443	1	
18	FILTER, PRESSURE LUBE	033447	1	
	SCREEN KIT, MESH FILTER	033441	1	
19	CLAMP, PLASTIC HOSE DIA. 8-12MM	F81080-1	2	
20	BOLT, M5X16-5.8-HEX HEAD FULL THREAD ZINC	F81000-51	4	
21	WASHER, M5, FLAT ZINC	F81052-1	4	
22	FITTING, TEE TVS LMS	099213-1	1	
23	FITTING, 1/8MPTX1/4TUBE,ELBOW,SWIVEL	P09736	2	
24	FITTING, 1/4NPT-3/8 BARB	014685	1	
25	HOSE, 1/4" OD X 6 1/2'	033456	1	
26	BRACKET, WATER TANK MOUNTING, PTD	096178-1	1	
27	BOLT M12X80-8.8	F81004-46	2	
28	WASHER, M12 , FLAT, ZINC	F81056-1	4	
29	NUT, M12, NYLON HEX ZINC LOCK	F81034-1	2	
30	BOLT, M6X45MM,HEX HEAD GR5(8.8)F/T ZINC	F81001-6	2	
31	WASHER, M6 SPLIT LOCK ZINC	F81053-3	2	

4.3 Saw Head Decals

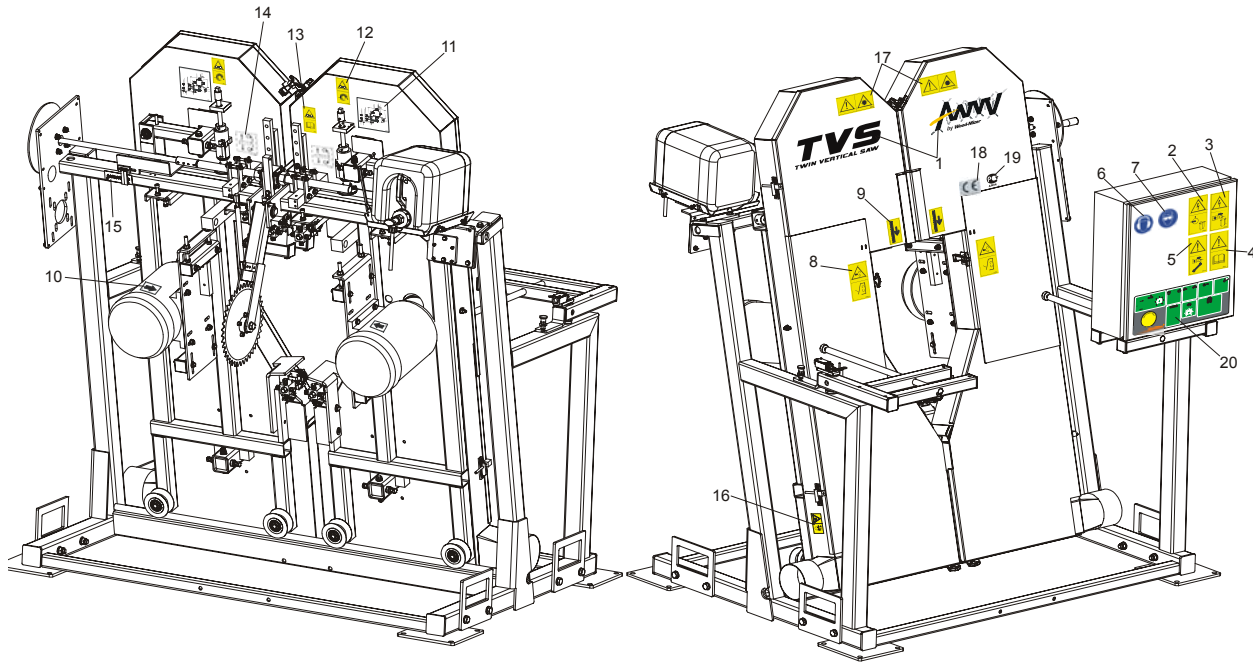

REF	DESCRIPTION (◆ Indicates Parts Available In Assemblies Only)	PART #	QTY.
	DECALS KIT, COMPLETE, TVS, PICTOGRAMS	099479	1
1	DECALS, TVS NAME	099422	1
2	DECAL, HIGH VOLTAGE IN ELECTRIC BOX	096316	1
3	DECAL, DISCONNECT POWER SUPPLY BEFOR OPENING THE BOX	096319	1
4	DECAL, READ THE MANUAL BEFORE OPERATING THE MACHINE	096317	1
5	DECAL, DISCONNECT POWER SUPPLY BEFORE SERVICING	098177	1
6	DECAL, EAR WARNING	S12005G	1
7	DECAL, EYE WARNING	S12004G	1
8	DECAL, CLOSE GUARDS PRIOR TO OPERATING THE MACHINE	099220	2
9	DECAL, BLADE MOVEMENT DIRECTION	096321	2
10	DECAL, MOTOR DIRECTION	S20097	2
11	DECAL, SETTING THE BLADE TENSION INDICATOR	092597	2
12	DECAL, BLADE TENSION - PICTOGRAM	099219	2
13	DECAL, BLADE TENSION - INSTRUCTION, PICTOGRAM	099223	1
14	DECAL, BLADE ALIGNMENT	P11789	2
15	SCALE, TVS METRIC	098619	1
16	DECAL, SAW DUST PROTECTION, PICTOGRAM	099222	2
17	DECAL, CAUTION - LASER BEAM (OPTIONAL)	099504	2
	TABLES DECALS, See Section 5.5		
18	DECAL, CE , CERTIFIED MACHINE (SMALL)	P85070	1
19	DECAL, GOST CERTIFIED MACHINE	099401	1
20	DECAL, TVS CONTROLS	099174	1

4

Saw Head Blade Housing Cover

4.4 Blade Housing Cover

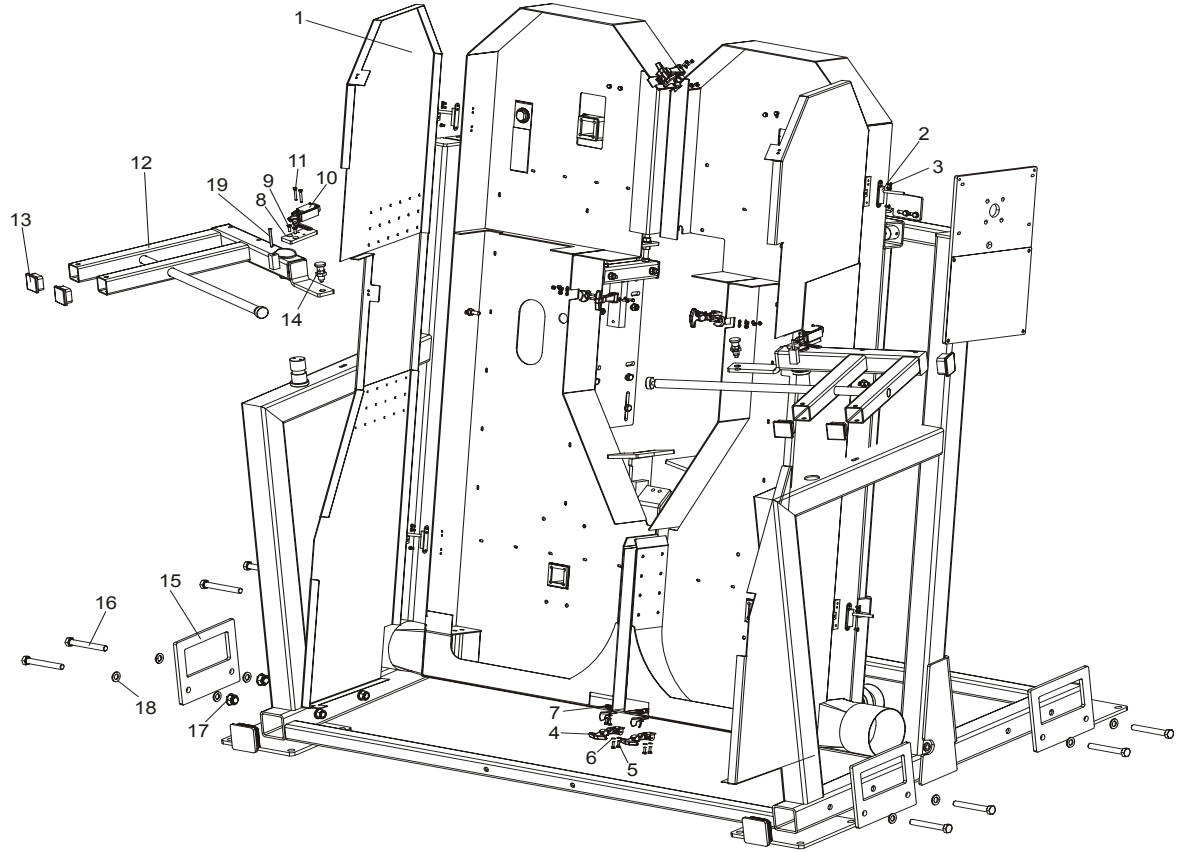

REF	DESCRIPTION (◆ Indicates Parts Available In Assemblies Only)	PART #	QTY.
1	COVER, BLADE HOUSING TVS LEFT WLDMT/PTD	098612-1 (LEFT)	1
	COVER, BLADE HOUSING TVS RIGHT WLDMT/PTD	096117-1 (RIGHT)	1
2	HINGE, COVER	096146	4
3	SCREW, M5X12- 5.8-B SLOTTED COUNTERSUNK ZINC	F81000-15	8
4	LATCH, FLEXIBLE DRAW	014829	6
5	BOLT, M5X16-5.8-HEX HEAD FULL THREAD ZINC	F81000-51	12
6	WASHER, M5, FLAT ZINC	F81052-1	24
7	NUT, M5-8- DIN 985 ZINC	F81030-2	12
8	FLAT BAR, LIMIT SWITCH MOUNTING ZINC	098760-1	2
9	SCREW, M6X16, HEX SOCKET HEAD CAP	F81001-21	4
10	SWITCH, GSCA 01S1 LIMIT	088407	2
11	BOLT, M5X35 8.8 HEX SOCKET HEAD CAP ZINC	F81000-73	4
12	ARM, CONTROL BOX TVS MOUNTING LEFT WLDMT/PTD	098611-1	2
	ARM, CONTROL BOX TVS MOUNTING RIGHT WLDMT/PTD	096370-1	2
13	CAP, 50X50(3-5MM THICK) #199274 SHR TUBE END	095371	4
14	PIN, DETENT	090197	2
15	PLATE, MOUNTING TVS	099145-1	4
16	BOLT, M16X120 -8.8- A2E ISO 24014	F81006-25	8

17	NUT, M16,HEX, NYLON ZINC LOCK	F81036-2	8	
18	WASHER, M16,FLAT ZINC	F81058-1	16	
19	PIN 5M6X50 DIN 6325 HRC60	F81048-8	2	

4

Saw Head

Saw Head Width Manual Adjustment Assembly

4.5 Saw Head Width Manual Adjustment Assembly

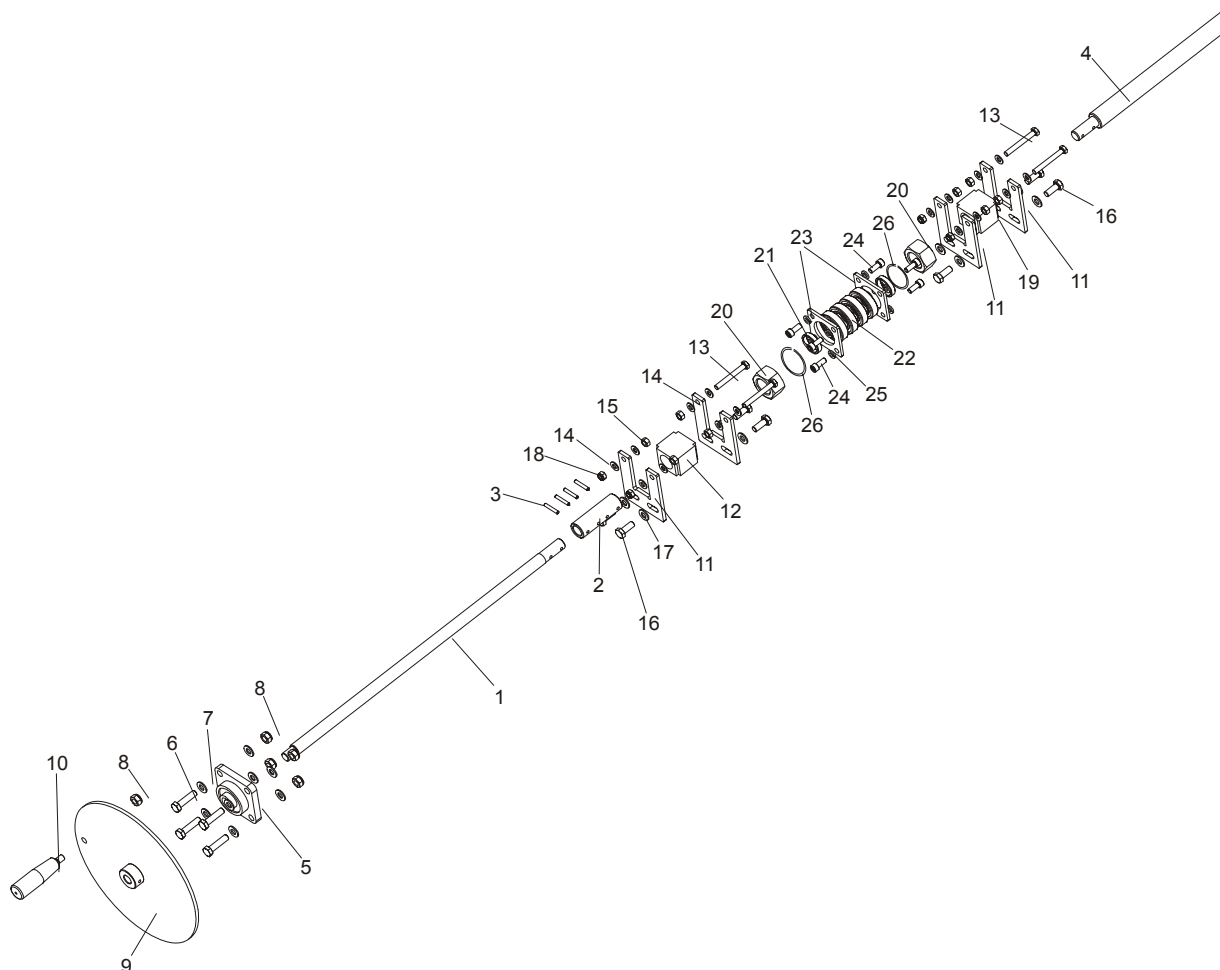

REF	DESCRIPTION (◆ Indicates Parts Available In Assemblies Only)	PART #	QTY.
	SCREW, SAW HEAD WIDTH ADJUSTMENT TVS COMPLETE	097664	1
1	ROD, SAW HEAD WIDTH ADJUSTMENT	096359-1	1
2	FASTENER, SAW HEAD WIDTH ADJUSTMENT SCREW	097665-1	1
3	PIN, 5X30 ROLL ZINC	F81044-21	4
4	SCREW, SAW HEAD WIDTH ADJUSTMENT TVS	096154-1	1
5	BEARING, UCF 204 W/HOUSING	097667	1
6	BOLT, M10X40-8.8 HEX HEAD FULL THREAD ZINC	F81003-16	4
7	WASHER, M10 FLAT ZINC	F81055-1	8
8	NUT, M10 NYLON HEX ZINC LOCK	F81033-1	5
9	PLATE, SAW HEAD ADJUSTMENT SCREW WLDMT/PTD	098617-1	1
10	KNOB, PLASTIC CRANK HANDLE	086338	1
11	BRACKET, TURNBUCKLE MOUNT ZINC-PLATED	096861-1	2
12	TURNBUCKLE, M30	096162-1	1
13	BOLT, M8X65 8.8 HEX HEAD FULL THREAD ZINC	F81002-9	2
14	WASHER, M8, FLAT,ZINC	F81054-1	8

15	NUT, M8 HEXAGON, GRADE 5.8 FREE ZINC	F81032-1	4	
16	BOLT, M10-1.5X25MM HH GR8.8	F81003-11	4	
17	WASHER, FLAT, M10, ZINC	F81055-1	4	
18	NUT, M8, HEXAGON, NYLON LOCK ZINC	F81032-2	2	
19	TURNBUCKLE - M30 LH	096161-1	1	
20	NUT, M30 HEX ZINC	F81038-3	2	
21	BUSHING, FI 34 X 38 X 8 SPACER	096356-1	2	
22	BEARING, 6006 2RSR	096191	4	
23	BRACKET, BEARING MOUNT BLOCK TVS-ZINC	096157-1	2	
24	BOLT, M8X20 -8.8-HEX SOCKET HEAD CAP ZINC	F81002-30	8	
25	WASHER, 8,2 ZINC	F81054-4	8	
26	WASHER, SPLIT LOCK Z30.5	F81068-1	2	

4

Saw Head

Saw Head Width Automatic Adjustment Assembly (Optional)

4.6 Saw Head Width Automatic Adjustment Assembly (Optional)

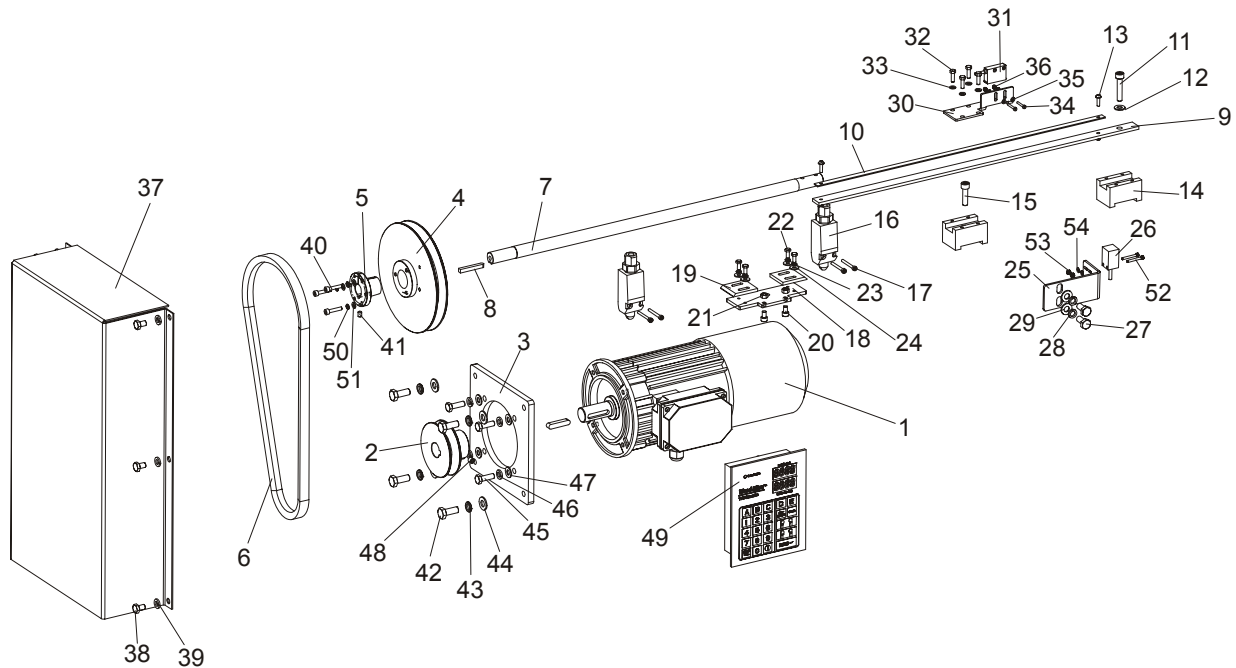

REF	DESCRIPTION (◆ Indicates Parts Available In Assemblies Only)	PART #	QTY.
	SCREW, SAW HEAD WIDTH ADJUSTMENT TVS COMPLETE	099185	1
1	MOTOR, SKH90-8L1 HPS 0,55KW, 750RPM.400V	098891	1
1	MOTOR, SKH90-8L1 0,55kW, 750RPM.400V (TVS-USA)	099515	1
2	BUSHING, TAPER	099317	1
3	BRACKET, MOTOR	099181-1	1
4	SHEAVE, TYPE B $\phi 180 \times \phi 30$	098117-1	1
5	BUSHING, TAPER	099317	1
6	BELT, TVS	099320	1
7	ROD, SAW HEAD WIDTH ADJUSTMENT	099180-1	1
8	KEY, AB 6X6X45 PARALLEL	089229	1
	FLAT BAR WITH MAGNETIC STRIP	099103-1	1
9	BAR, FLAT	099103	1
10	STRIP, MB320 (1m) MAGNETIC	096014-1	1
11	SCREW, M8X40 -8.8- HEX SOCKED HEAD CAP ZINC	F81002-29	1
12	WASHER, M8, FLAT,ZINC	F81054-1	1
13	WASHER, 4,3 FLAT ZINC	F81051-2	1
14	MOUNTING BLOCK WITH MAGNETIC STRIP	099102	2
15	SCREW, M8X30 -8.8- HEX SOCKED HEAD CAP ZINC	F81002-31	1
16	LIMIT SWITCH	089816	2
17	BOLT, M3X20-5.8-A-PAN HEAD	F81000-8	4
	LIMIT SWITCH ASSEMBLY	098992	1
18	PLATE, LIMIT SWITCH MOUNT	098988-1	1
19	BAR, LIMIT SWITCH FLAT	098989	2
20	SCREW, M6X10 -8.8- HEX SOCKED HEAD CAP ZINC	F81001-12	2
21	NUT, M6, HEXAGON,FREE, GRADE 5(8.8)ZINC	F81031-1	2
22	BOLT, M5 X 12-5.8-HEX HEAD FULL THREAD ZINC	F81000-5	4

23	WASHER, M5 SPLIT LOCK	F81052-2	4	
24	WASHER, 5,5 FLAT ZINC SPECIAL	F81052-3	4	
25	BRACKET, CALIBRATING SENSOR, ZINC	100630-1	1	
26	SENSOR, SW08 SETWORKS CALIBRATING	098051	1	
27	BOLT M8X16 -8.8-B-FE/ZN5	F81002-20	2	
28	WASHER SPREZ 8,2 FE/ZN9	F81054-4	2	
29	WASHER, 8.4 FLAT,ZINC	F81054-1	2	
30	BRACKET, SENSOR	099104-1	1	
31	SENSOR ASSY, MSK-320	096014	1	
32	BOLT, M5X16 -8.8- FHEX HEAD FULL THREAD ZINC	F81000-20	4	
33	WASHER, M5, FLAT ZINC	F81052-1	4	
34	SCREW, M3X20-5.8-A-PAN HEAD	F81000-8	2	
35	WASHER, 3,2 FLAT ZINC	F81050-2	4	
36	NUT, M3-6- HEX NYLON ZINC LOCK	F81028-2	2	
37	COVER, SAW HEAD WIDTH ADJUSTMENT TVS	098121-1	1	
38	BOLT, M8X12MM, HH FULL THREAD,GR8.8,ZINC	F81002-6	6	
39	WASHER, 8,2 SPLIT LOCK	F81054-4	6	
40	SCREW, M5X25-8.8-HEX SOCKED HEAD CAP ZINC	F81000-7	1	
41	SCREW, M6X8 PAN HEAD	F81013-1	1	
42	BOLT, M10-1.5X25MM HH GR8.8	F81003-11	4	
43	WASHER, M10 SPLIT LOCK ZINC	F81055-2	4	
44	WASHER, FLAT, M10, ZINC	F81055-1	4	
45	BOLT, M8 X 25MM HEX HEAD GR 5.8 ZINC	F81002-5	4	
46	WASHER, 8,2 SPLIT LOCK ZINC	F81054-4	4	
47	WASHER, M8, FLAT,ZINC	F81054-1	4	
48	SCREW, SET,M8X8-33H FE/ZN HEX SCKT HEAD	F81014-1	1	
49	CONTROLLER, TVS	099178	1	
50	WASHER, M5 SPLIT LOCK	F81052-2	3	
51	WASHER, M5, FLAT ZINC	F81052-1	3	
52	SCREW M3X25-4.8- FE/ZN5	F81000-84	2	
53	NUT M3-6-FE/ZN5	F81028-2	2	
54	WASHER 3,2 FE/ZN5	F81050-2	2	

4.7 Saw Head Width Indicator

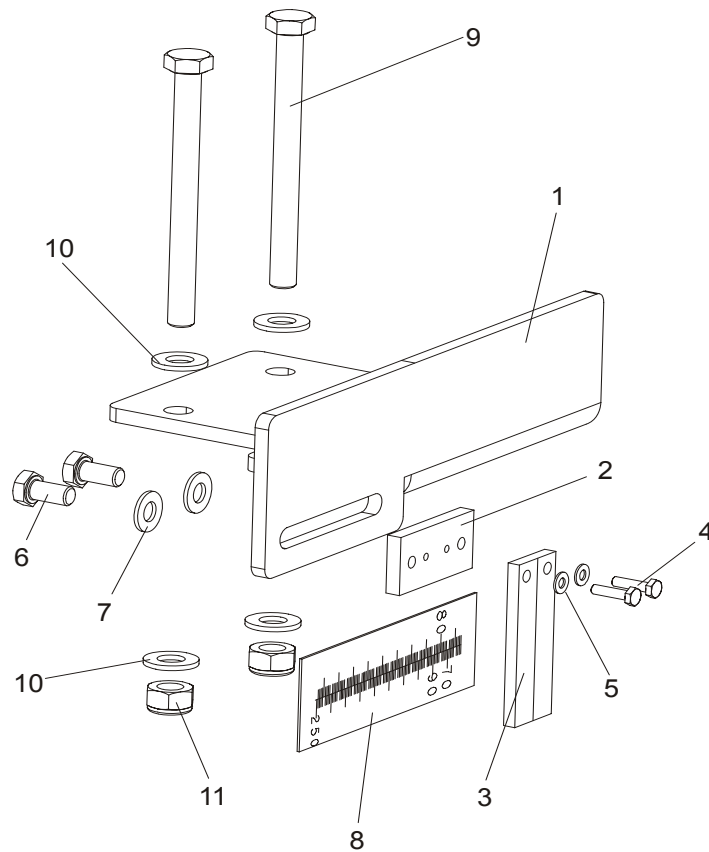

REF	DESCRIPTION (◆ Indicates Parts Available In Assemblies Only)	PART #	QTY.
	SCALE INDICATOR, TVS COMPLETE	098756	1
1	BRACKET, SCALE INDICATOR TVS	098622-1	1
2	BLOCK, BLADE WIDTH INDICATOR REDUCER	094438-1	1
3	INDICATOR, BLADE WIDTH SCALE	094821	1
4	BOLT, M4X16 5.8 HEX HEAD FULL THREAD ZINC	F81011-6	2
5	WASHER, 4,3 FLAT ZINC	F81051-2	2
6	BOLT, M8X16 -8.8-B-HEX HEAD FULL THREAD ZINC	F81002-20	2
7	WASHER, M8 FLAT ZINC	F81054-1	2
8	SCALE, TVS METRIC	098619	1
9	BOLT, M10X110 8.8 HEX HEAD ZINC	F81003-43	2
10	WASHER, M10 FLAT ZINC	F81055-1	4
11	NUT, M10 NYLON HEX ZINC LOCK	F81033-1	2

4.8 Saw Head Slide Brackets

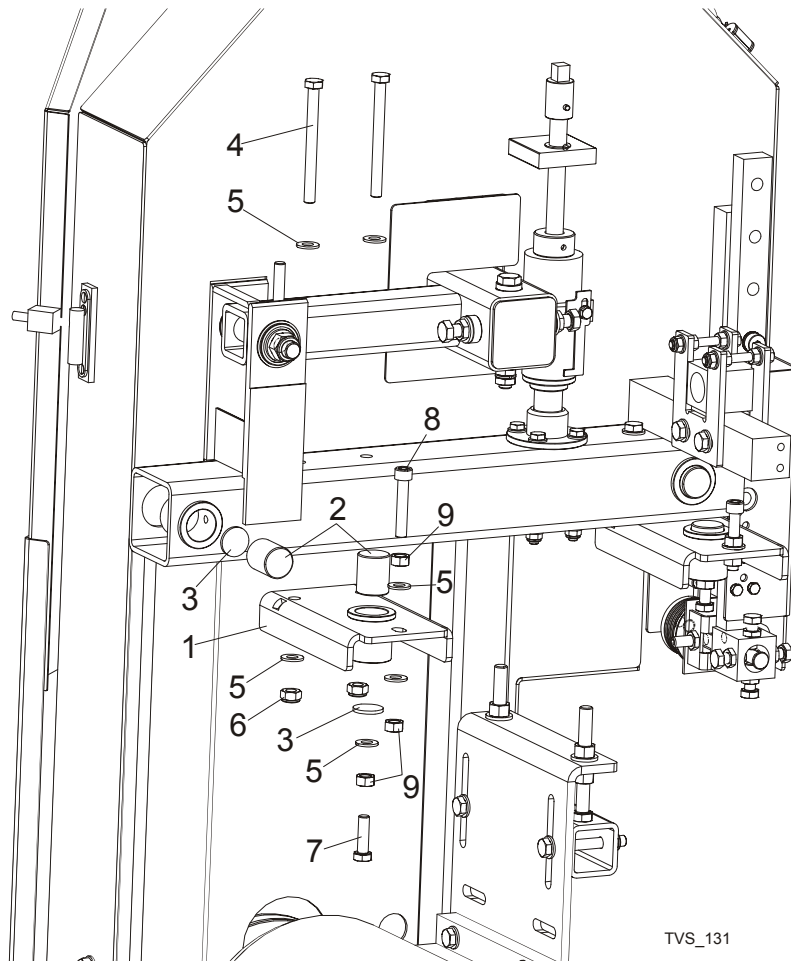

REF	DESCRIPTION (◆ Indicates Parts Available In Assemblies Only)	PART #	QTY.
1	BRACKET, SLIDE LOWER TVS	096838-1	2
2	ROD, SLIDE TVS	096128	4
3	WASHER, BUSHING SLIDE ZINC TVS	096129-1	4
4	BOLT, M10X110 8.8 ZINC	F81003-43	4
5	WASHER, 10.5 FLAT ZINC	F81055-1	9
6	NUT, M10-8-B NYLON HEX ZINC LOCK	F81033-1	4
7	BOLT, M10X35-8.8 HEX HEAD FULL THREAD ZINC	F81003-17	2
8	SCREW, M10X55-8.8 HEX SOCKET HEAD CAP	F81003-55	2
9	NUT, M10-8-B-FE	F81033-3	6

4.9 Hold-down roller

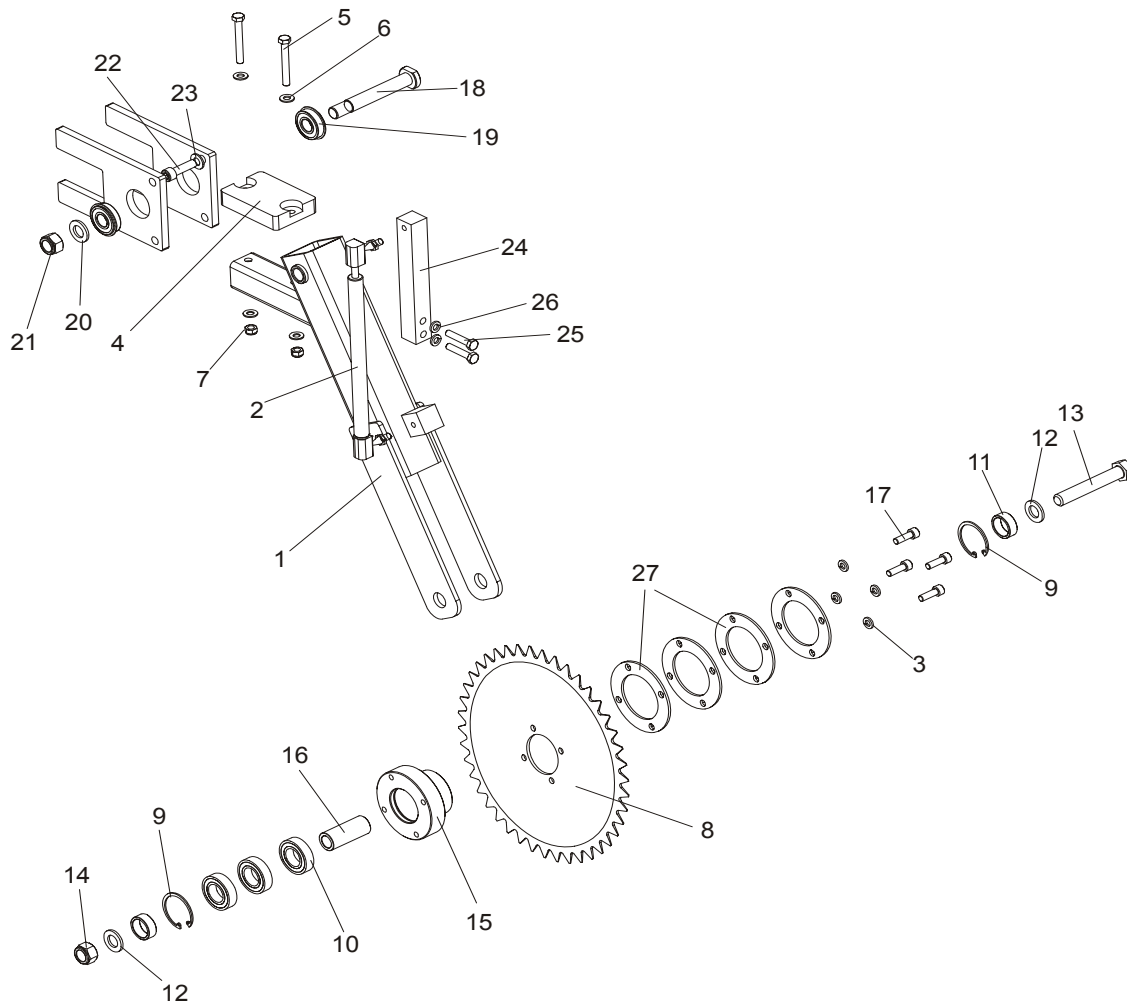

REF	DESCRIPTION (◆ Indicates Parts Available In Assemblies Only)	PART #	QTY.
	ROLLER, HOLD-DOWN TVS	097954	1
1	ARM, LOWER HOLD-DOWN WLDMT/PTD	097953-1	1
2	SPRING, 340N GAS COMPLETE	089212	1
3	WASHER, 8,2 SPLIT LOCK ZINC	F81054-4	4
4	BUMPER, GRENE 70 3201 0010. SHR RUBBER	094969	1
5	BOLT, M8 X 65MM HH GRADE 5.8 ZINC	F81002-3	2
6	WASHER, M8 FLAT ZINC	F81054-1	4
7	NUT, M8 HEX NYLON LOCK ZINC	F81032-2	2
8	WHEEL, LOG HOLD-DOWN TVS	096352-1	1
9	RING, W47 SPRING RETAINING	089653	2
10	BEARING, 6005 2RS CX	089652	3
11	BUSHING, FI 25,5 X 32X12 SPACER ZINC	097942-1	2
12	WASHER, M16 FLAT ZINC	F81058-1	2
13	BOLT, M16X100MM HEX HEAD FULL THRD ZINC	F81006-2	1
14	NUT, M16,HEX NYLON ZINC LOCK	F81036-2	1

15	SHAFT, LOG HOLD-DOWN WHEEL ZINC-PLATED	096351-1	1	
16	BUSHING, FI 25X16,5X60 SPACER ZINC	098610-1	1	
17	BOLT, M8X25 -8.8- HEX SOCKET HEAD CAP ZINC	F81002-21	4	
18	PIN, IDLER ARM MOUNT	086404	1	
19	BEARING W/SNAP RING 6203-2RS	086395	2	
20	WASHER, M16 FLAT ZINC	F81058-1	1	
21	NUT, M16 HEX NYLON ZINC LOCK	F81036-2	1	
22	BOLT, M10X35 HEX SOCKET HEAD CAP ZINC	F81003-56	1	
23	WASHER, M10 FLAT ZINC	F81055-1	1	
24	BRACKET, GAS SPRING ZINC	096160-1	1	
25	BOLT, 8MM X 1.25 X 40MM HH ZINC	F81002-15	2	
26	WASHER, 8,2 SPLIT LOCK ZINC	F81054-4	2	
27	SPACER	099530-1	4	

4.10 Blade Drive Motor

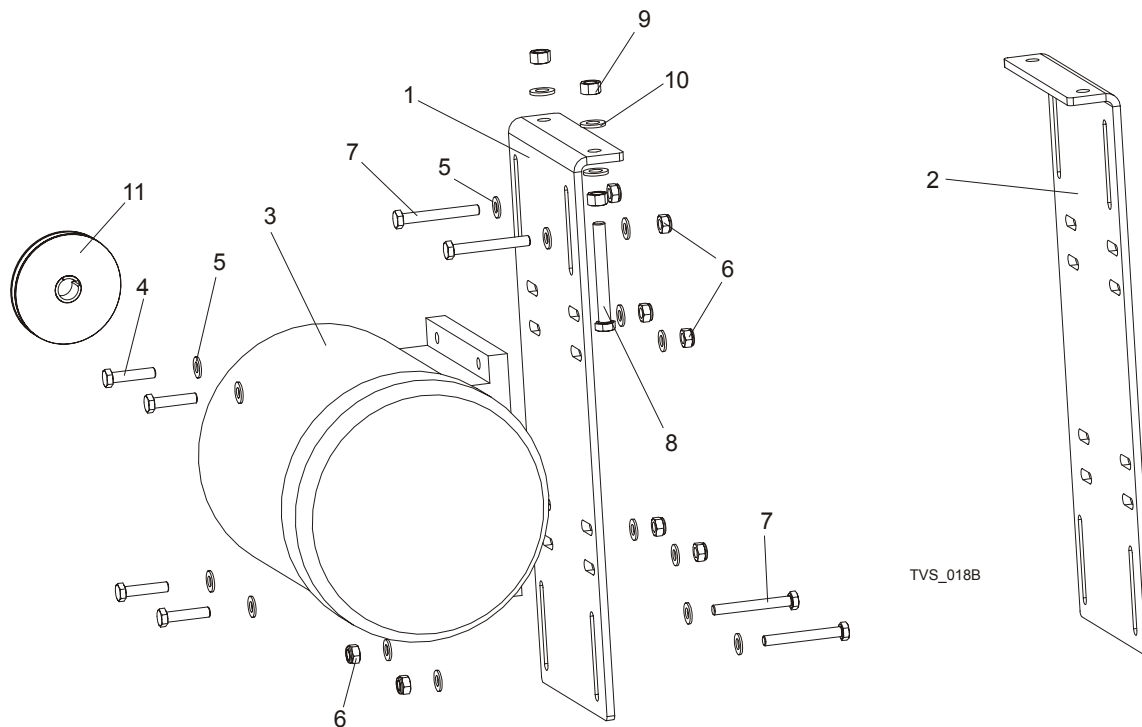

REF	DESCRIPTION (◆ Indicates Parts Available In Assemblies Only)	PART #	QTY.
1	PLATE, MOTOR MOUNT RIGHT - PTD	096123-1	1
	PLATE, MOTOR MOUNT RIGHT - PTD (TVS-USA)	099398-1	1
2	PLATE, MOTOR MOUNT LEFT - PTD	098436-1	1
	PLATE, MOTOR MOUNT LEFT - PTD (TVS-USA)	099397-1	1
3	MOTOR, 11KW PSSG-132S -2 HM+132	089049	2
	MOTOR, 15KW(20HP)380-420V ELECTRIC (TVS-USA)	086856	2
4	BOLT, M10X45MM HEX HEAD FULL THRD ZINC	F81003-3	8
5	WASHER, M10 FLAT ZINC	F81055-1	32
6	NUT, M10 NYLON HEX ZINC LOCK	F81033-1	16
7	BOLT, M10X80 -8.8- HEX ZINC	F81003-50	8
8	BOLT, M12X100 8.8 HEX HEAD FULL THREAD ZINC	F81004-45	4
9	NUT, M12 HEX GRADE 5.8 ZINC	F81034-1	4
10	WASHER, M12 FLAT ZINC	F81056-1	8
11	PULLEY, SPB190/1 W/2012/38 TAPER SPLIT BUSHING	099601	2
	PULLEY ϕ 150/ FI42 F02329+T31081 (TVS-USA)	099503	1

4.11 Saw Head Support Rollers

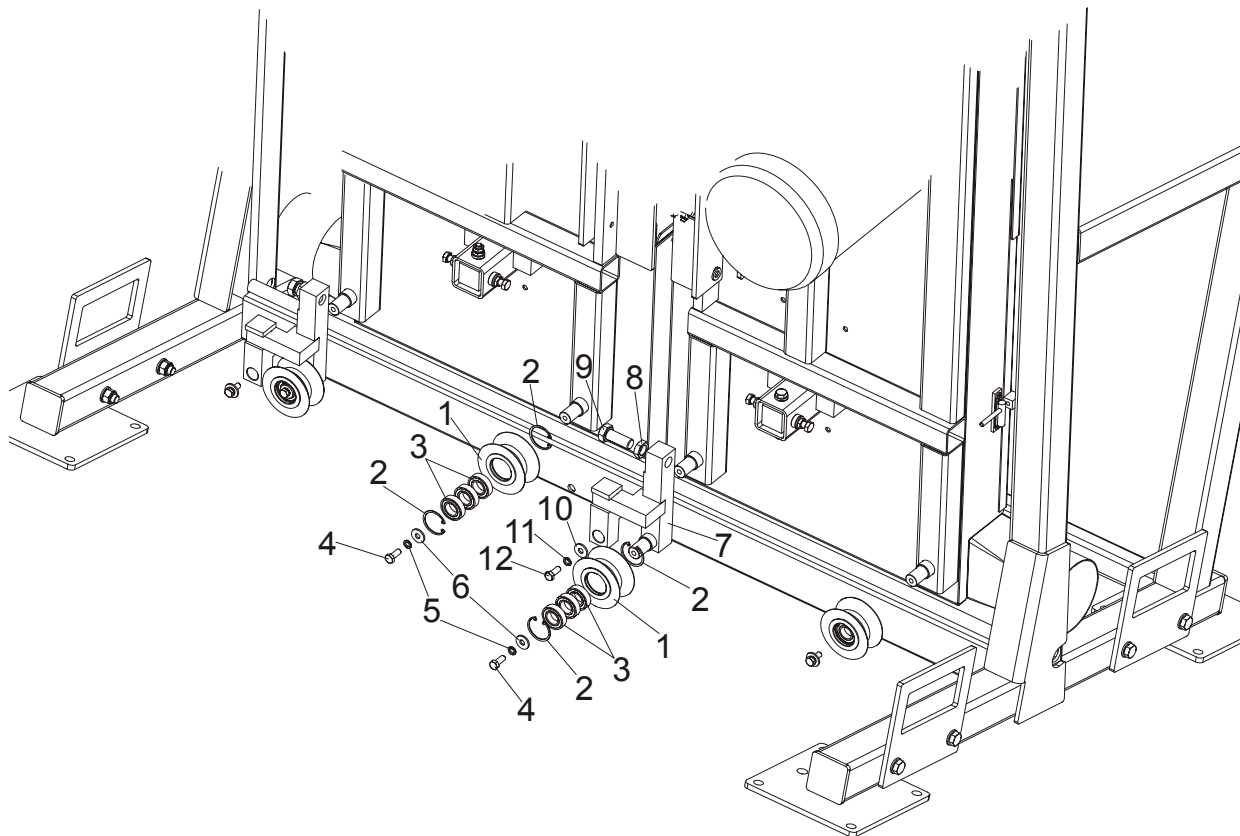

REF	DESCRIPTION (◆ Indicates Parts Available In Assemblies Only)	PART #	QTY.
	ROLLER, TVS SAW HEAD SUPPORT, COMPLETE	096835	4
1	ROLLER, TVS SAW HEAD SUPPORT, PTD, ϕ 106	096834-1	1
	ROLLER, TVS SAW HEAD SUPPORT, PTD, ϕ 102 (TVS USA)	096834-1S	1
2	RING, W47 SPRING RETAINING	089653	2
3	BEARING, 6005 2RS CX	089652	3
4	BOLT M10X25 8.8 PN-M/82105	F81003-31	1
5	WASHER,10.2 SPLIT LOCK ZINC	F81055-2	1
6	WASHER.10,5 FE/ZN5 PN-59/82030	F81055-6	1
	ROLKA PROWADZĄCA REG. GŁOWICY TVS KPL.	100179	2
7	UCHWYT ROLKI REGULACYJNEJ	100177-1	1
	ROLLER, TVS SAW HEAD SUPPORT, COMPLETE	096835	1
8	NAKRETKA NISKA M20X1,5 FE/ZN5 PN-M/82153	F81037-7	1
9	ŚRUBA M20X1,5X50-8.8-B-FE/ZN5 PN/M-82105	F81007-2	1
10	WASHER.10,5 FE/ZN5 PN-59/82030	F81055-6	1
11	WASHER,10.2 SPLIT LOCK ZINC	F81055-2	1
12	BOLT M10X25 8.8 PN-M/82105	F81003-31	1

4.12 Electric Box

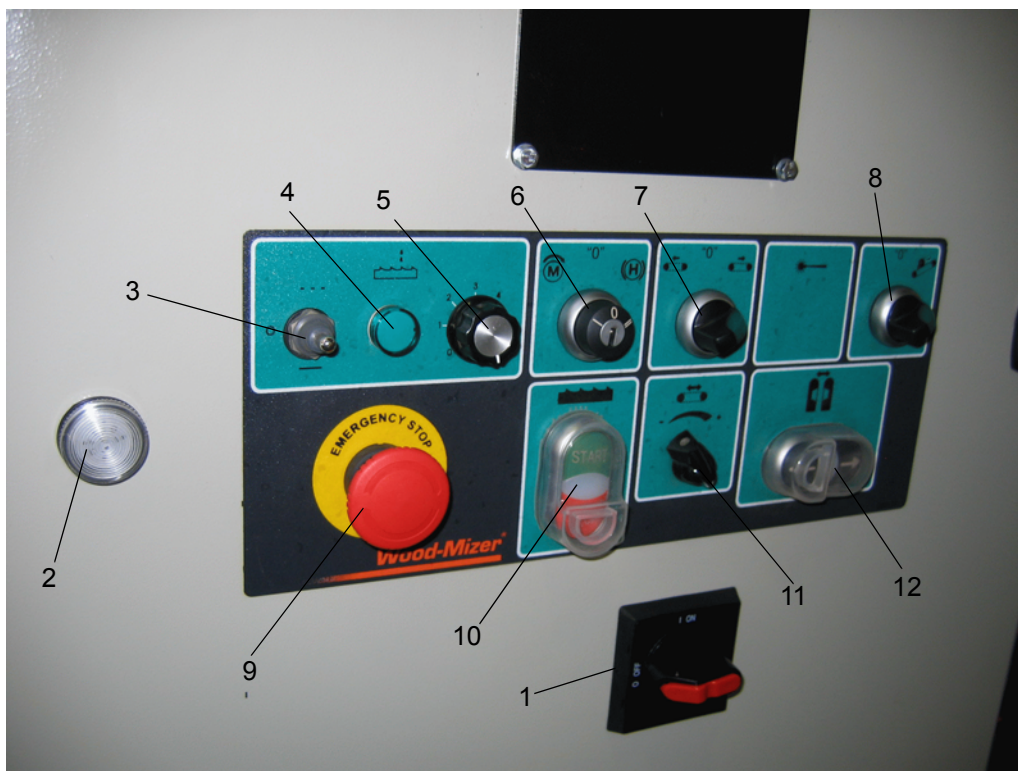

REF	DESCRIPTION (◆ Indicates Parts Available In Assemblies Only)	PART #	QTY.
	ELECTRIC BOX TVS	096222	1
	ELECTRIC BOX TVS USA	096222-4	1
1	SWITCH ABB OT45E3	095473	1
	HANDWHEEL OHB2AJ ABB	088265-1	1
	AXIS OXS5X160 ABB	088265-2	1
2	CONTROL LIGHT, WHITE	090488	1
3	SWITCH, DPDT ON/OFF/ON 15A TOGGLE	024588	1
4	CONTROL LIGHT XB6 AV 3BB	087348	1
5	KNOB, 1/4 ID FLUTED ROUND PLASTIC	033478	1
	POT, 500K 2W 10% CP PANEL MOUNT	024553	1
6	KEY SWITCH M22 - 3 POSITIONS	091361	1
7	SWITCH M22 3 POSITIONS, ILLUMINATED	091359	1
8	SWITCH, 2 POSITIONS, ILLUMINATED	091467	1
9	SWITCH EMERGENCY XB2 BS542	086556	1
10	START/STOP SWITCH 24V	090452	1
11	KNOB, SPEED CONTROL	P06257	1
	POTENTIOMETER, 1K LTAGA	E20519	1
12	PUSH BUTTON M22-DD-S-X7/X7	090917	1
	CONTACTORS M22-K10	091362	1

4.13 Laser Assembly (Optional)

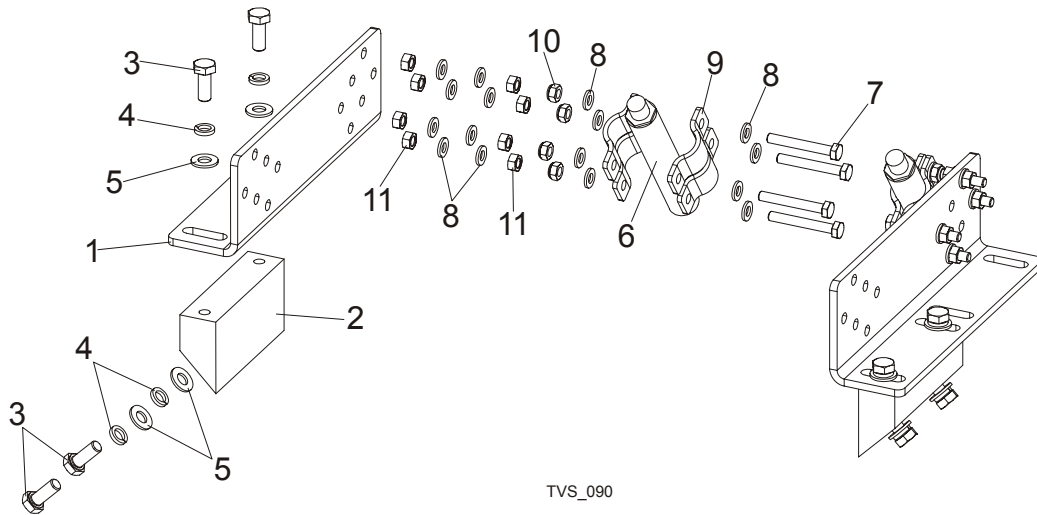

TVS_090

LP.	OPIS (♦ wskazuje części dostępne jedynie w zespołach)	NR CZĘŚCI	SZT.
	TVS LASER ASSEMBLY, COMPLETE	100079	1
1	PLATE, TVS LASER MOUNTING	098304	2
2	BRACKET, TVS LASER	098303	2
3	BOLT, M8X20MM, HH, GR 8.8, FULL THRD, ZINC	F81002-1	8
4	WASHER, 8.2 SPLIT LOCK ZINC	F81054-4	8
5	WASHER, 8.4 FLAT ZINC	F81054-1	8
6	LASER, 3FDL LINEAR	091531	2
7	BOLT, M6X45-8.8 HH, FULL THRD ZINC	F81001-45	8
8	WASHER, M6, FLAT, ZINC	F81053-1	32
9	BRACKET, 3/8" (12-17) TUBE MOUNTING	099872	4
10	NUT, M6-8-B HEX, NYLON LOCK ZINC	F81031-2	8
11	NUT, M6, HEXAGON, FREE, GRADE 5(8.8) ZINC	F81031-1	16

SECTION 5 INFEED & OUTFEED TABLES

5.1 TVS Infeed

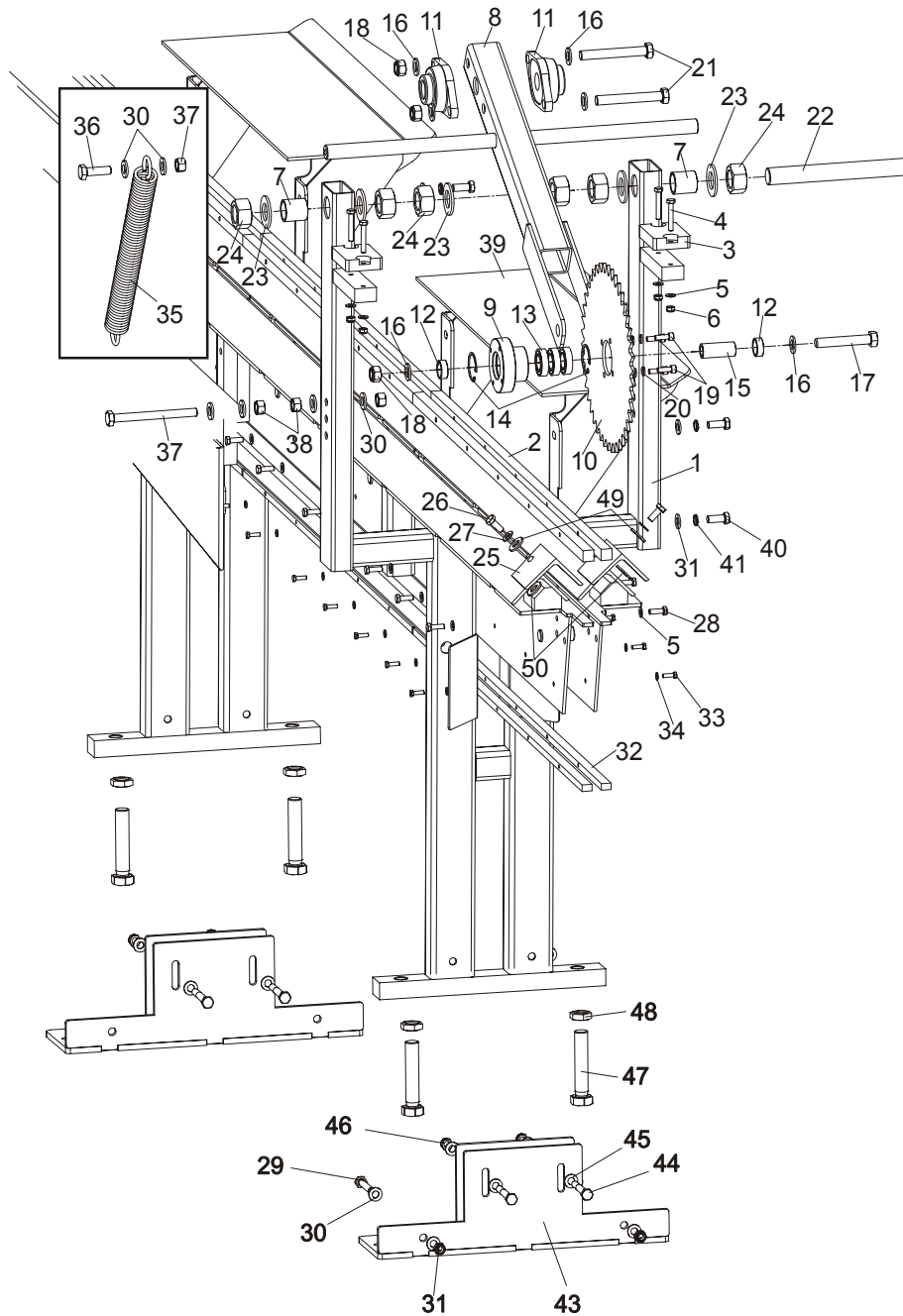

REF	DESCRIPTION (◆ Indicates Parts Available In Assemblies Only)	PART #	QTY.	
	INFEED, TVSIV2.4I	098946	1	
	INFEED, TVSIV2.4M	098947	1	
	TVS INFEED, SHORT COMPLETE	097641	1	
1	TVS INFEED, SHORT	097643-1	1	◆

2	BAR, CHAIN OUTER SLIDE	098652-1	2	
	BAR, CHAIN SLIDE ZINC	096199-1	4	
3	BUMPER, GRENE 70 3201 0010. SHR RUBBER	094969	2	
4	BOLT, M8X50-8.8-HEX HEAD FULL THREAD ZINC	F81002-19	4	
5	WASHER, M8 FLAT ZINC	F81054-1	42	
6	NUT, M8 HEX NYLON LOCK ZINC	F81032-2	4	
7	BUSHING, SPACER ZINC	096355-1	2	
	ARM, COMPLETE ROLLER HOLD-DOWN	096350	1	
8	ARM, ROLLER HOLD-DOWN WLDMT/PTD	096348-1	1	
9	SHAFT, LOG HOLD-DOWN WHEEL ZINC-PLATED	096351-1	1	
10	WHEEL, LOG HOLD-DOWN ZINC-PLATED	096352-1	1	
11	BEARING, UCFL 206 CX	090851	2	
12	BUSHING, FI 25,5 X 32X12- SPACER ZINC	097942-1	2	
13	BEARING, 6005 2RS CX	089652	3	
14	RING, W47 SPRING RETAINING	089653	2	
15	BUSHING, FI 25X16,5X60 -SPACER ZINC	098610-1	1	
16	WASHER, M16 FLAT ZINC	F81058-1	6	
17	BOLT, M16X100MM HEX HEAD FULL THRD ZINC	F81006-2	1	
18	NUT, M16 HEX NYLON ZINC LOCK	F81036-2	3	
19	BOLT, M8x25 -8.8- HEX SOCKET HEAD CAP	F81002-21	4	
20	WASHER, 8,2 SPLIT LOCK ZINC	F81054-4	4	
21	BOLT, M16x120 -8.8- A2E ISO 24014	F81006-25	2	
22	ROD, M30 (690) HOLD-DOWN ARM THREADED ZINC	096344-1	1	
23	WASHER, 31 FLAT ZINC	F81061-9	6	
24	NUT, M30 HEX ZINC	F81038-3	6	
25	ANGLE, TVS INFEED SHORT PTD	098325-1	2	
26	Bolt, M10-1.5x25mm HH Gr8.8	F81003-11	2	
27	WASHER, M10 FLAT ZINC	F81055-1	2	
28	BOLT, M8 x 25mm HEX HEAD GR 5.8 ZINC	F81002-5	38	
29	BOLT, M12x75-8.8- HEX HEAD FULL THREAD ZINC	F81004-10	2	
30	WASHER, M12 FLAT ZINC	F81056-1	32	
31	NUT, M12 HEX NYLON ZINC LOCK	F81034-2	2	
32	BAR, CHAIN SUPPORT	098942-1	6	
33	BOLT, M6X20MM, HH FULL THREAD ZINC	F81001-2	30	
34	WASHER, M6 FLAT ZINC	F81053-1	30	
35	SPRING, FI 4,5X FI 35X303	091863	2	
36	BOLT, M12x40 8.8 HEX HEAD FULL THR.ZINC	F81004-4	2	
37	BOLT, M12x130 8.8 HEX HEAD FULL THR.ZINC	F81004-55	2	
38	NUT, M12, HEXAGON, GRADE 5.8, ZINC	F81034-1	8	
43	LEG, TVS	099534-1	2	
44	BOLT, M12X90-8.8 HEX HEAD ZINC	F81004-2	2	
45	WASHER, M12, FLAT, ZINC	F81056-1	4	
46	NUT, M12-8, HEX, NYLON, ZINC, LOCK	F81034-2	2	
47	BOLT M24X120 8.8 FE/ZN5	F81009-6	2	
48	NUT M24-04-B	F81039-3	2	
49	WASHER, 10.5X19X0.5 FLAT	100623	2	
50	WASHER, 10.5X19X1 FLAT	100624	2	

	INFEED, TVSIV3.6I	098948	1	
	INFEED, TVSIV3.6M	098949	1	
	TVS INFEED, LONG COMPLETE	098747	1	
1	TVS INFEED, LONG	098742-1	1	◆
2	BAR, CHAIN OUTER SLIDE - ZINC	098652-1	2	
	BAR, CHAIN SLIDE - ZINC	096199-1	6	
3	BUMPER, -GRENE 70 3201 0010. SHR RUBBER	094969	2	
4	BOLT, M8X50-8.8-HEX HEAD FULL THREAD ZINC	F81002-19	4	
5	WASHER, M8 FLAT ZINC	F81054-1	42	
6	NUT, M8 HEX NYLON LOCK ZINC	F81032-2	4	
7	BUSHING, SPACER ZINC	096355-1	2	
	ARM, COMPLETE ROLLER HOLD-DOWN	096350	1	
8	ARM, ROLLER HOLD-DOWN WLDMT/PTD	096348-1	1	
9	SHAFT, LOG HOLD-DOWN WHEEL ZINC-PLATED	096351-1	1	
10	WHEEL, LOG HOLD-DOWN ZINC-PLATED	096352-1	1	
11	BEARING, UCFL 206 CX	090851	2	
12	BUSHING, FI 25,5 X 32X12-SPACER ZINC	097942-1	2	
13	BEARING, 6005 2RS CX	089652	3	
14	RING, W47 SPRING RETAINING	089653	2	
15	BUSHING, FI 25X16,5X60 -SPACER ZINC	098610-1	1	
16	WASHER, M16 FLAT ZINC	F81058-1	6	
17	BOLT, M16X100MM HEX HEAD FULL THRD ZINC	F81006-2	1	
18	NUT, M16 HEX NYLON ZINC LOCK	F81036-2	3	
19	BOLT, M8x25 -8.8- HEX SOCKET HEAD CAP	F81002-21	4	
20	WASHER, 8,2 SPLIT LOCK ZINC	F81054-4	4	
21	BOLT, M16x120 -8.8- A2E ISO 24014	F81006-25	2	
22	ROD, M30 (690) HOLD-DOWN ARM THREATED ZINC	096344-1	1	
23	WASHER, 31 FLAT ZINC	F81061-9	6	
24	NUT, M30 HEX ZINC	F81038-3	6	
25	ANGLE, TVS INFEED SHORT PTD	098325-1	2	
26	Bolt, M10-1.5x25mm HH Gr8.8	F81003-11	2	
27	WASHER, M10 FLAT ZINC	F81055-1	2	
28	BOLT, M8 x 25mm HEX HEAD GR 5.8 ZINC	F81002-5	38	
29	BOLT, M12x75-8.8-HEX HEAD FULL THREAD ZINC	F81004-10	2	
30	WASHER, M12 FLAT ZINC	F81056-1	32	
31	NUT, M12 HEX NYLON ZINC LOCK	F81034-2	2	
32	BAR, CHAIN SUPPORT	098942-1	8	
33	BOLT, M6X20MM HH FULL THREAD ZINC	F81001-2	38	
34	WASHER, M6 FLAT ZINC	F81053-1	38	
35	SPRING, FI 4,5X FI 35X303	091863	2	
36	BOLT, M12x40 8.8 HEX HEAD FULL THR.ZINC	F81004-4	2	
37	BOLT, M12x130 8.8 HEX HEAD FULL THR.ZINC	F81004-55	2	
38	NUT, M12, HEXAGON, GRADE 5.8, ZINC	F81034-1	8	
43	LEG, TVS	099534-1	2	
44	BOLT, M12X90-8.8 HEX HEAD ZINC	F81004-2	2	
45	WASHER, M12, FLAT, ZINC	F81056-1	4	
46	NUT, M12-8, HEX, NYLON, ZINC, LOCK	F81034-2	2	

47	BOLT M24X120 8.8 FE/ZN5	F81009-6	2	
48	NUT M24-04-B	F81039-3	2	
49	WASHER, 10.5X19X0.5 FLAT	100623	2	
50	WASHER, 10.5X19X1 FLAT	100624	2	
39	TABLE, TVS SIDE	098115-1 ¹	2/4	
40	BOLT, M12x30-8.8	F81004-22	16	
41	WASHER, M12 SPLIT LOCK ZINC	F81056-2	16	
42	TABLE, LOG RAMP COMPLETE	098340 ²	1	

¹ 2 pcs with I-version table (in line), 4pcs with M-version table (manual).

² Only with I-version table (in line).

5.2 Infeed table chain tension wheel

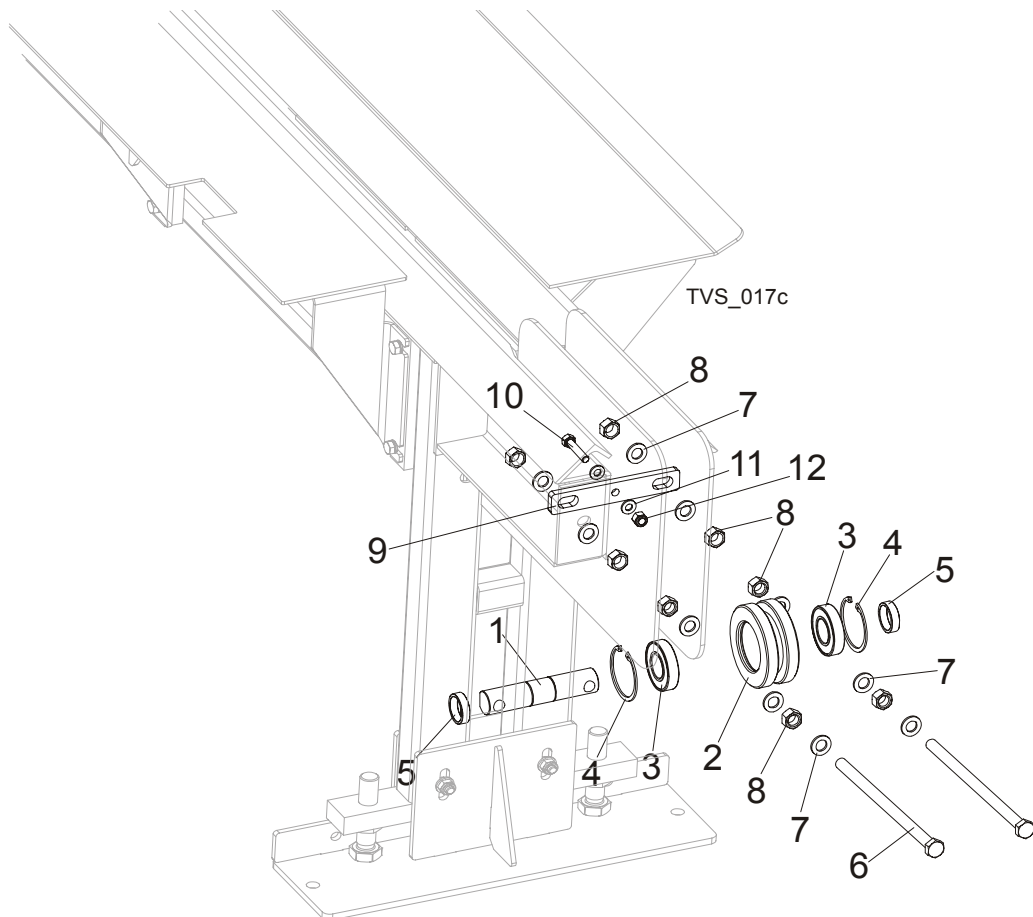

REF	DESCRIPTION (◆ Indicates Parts Available In Assemblies Only)	PART #	QTY.
	CHAIN TENSION WHEEL COMPLETE	097655	1
1	SHAFT, CHAIN TENSION WHEEL	096207-1	1
2	WHEEL, TVS CHAIN TENSION	096208-1	1
3	BEARING, 6207-2RS, C3, 35X72X17	014811	2
4	RING, W72 SPRING RETAINING	F81090-4	2
5	BUSHING, FI 36 X 44 X 12 -SPACER ZINC	096602-1	2
6	BOLT, M16X290-8.8 -A2 HEX HEAD FULL THREAD ZINC	F81006-27	2
7	WASHER, M16 FLAT ZINC	F81058-1	8
8	NUT, M16 HEX GRADE 5.8 PLAIN	F81036-1	8
	SCRAPER, TVS TENSIONING WHEEL, COMPLETE	100752	1
9	HOLDER, TENSIONING WHEEL SCRAPER	100751-1	1
10	BOLT, M10X40-8.8	F81003-16	1
11	WASHER, 10.5 FLAT ZINC	F81055-1	2
12	NUT, M10-8-B NYLON HEX ZINC LOCK	F81033-1	1

5.3 Chain Drive Assembly, TVS

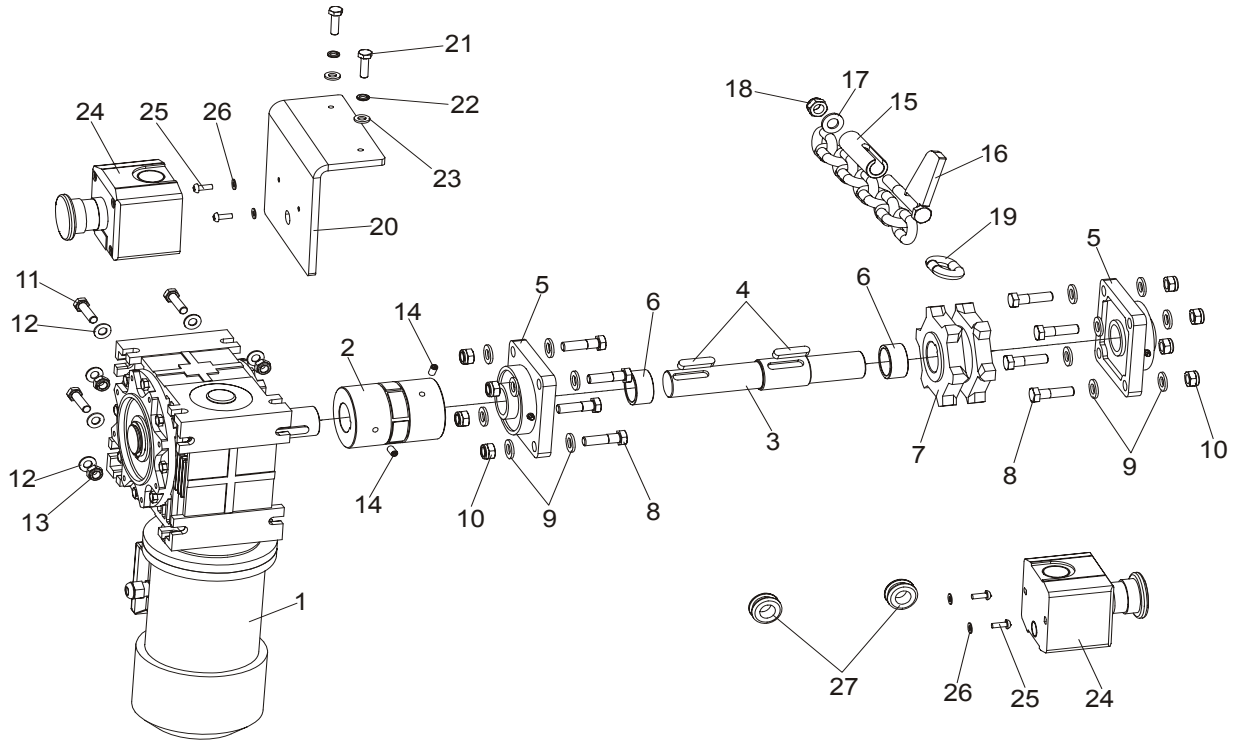

REF	DESCRIPTION (◆ Indicates Parts Available In Assemblies Only)	PART#	QTY.
	CHAIN DRIVE, TVS COMPLETE	098671	1
1	MOTOREDUCER, MR-80/64/1.1-1400/K3/V6	098663	1
2	COUPLING, "ROTEX-38 ST 92 1A 38X45, 1A 35X45	098664	1
3	SHAFT, TVS CHAIN DRIVE ZINC-PLATED	096203-1	1
4	KEY, A10x8x45 PARALLEL	091312	2
5	BEARING, UCF 207 W/HOUSING	097668	2
6	BUSHING, Φ36 X Φ44X22-SPACER ZINC	099959-1	2
7	SPROCKET, 16B 20Z	097657	1
8	BOLT, M12x45-8.8-HEX HEAD ZINC	F81004-32	8
9	WASHER, M12 FLAT ZINC	F81056-1	16
10	NUT, M12 HEX NYLON ZINC LOCK	F81034-2	8
11	BOLT, M10x40-8.8 HEX HEAD FULL THREAD ZINC	F81003-16	4
12	WASHER, M10 FLAT ZINC	F81055-1	8
13	NUT, M10, NYLON HEX ZINC LOCK	F81033-1	4
14	SCREW, M8x16-33H HEX SOCKED FLAT POINT SET	F81014-2	2

15	COMPLETE CHAIN W/DOGS	097650 ¹	1	
	Chain, TVS	097649	1	
	CHAIN, L.13321 W/DOGS	098809 ²	1	
	Chain	098808	1	
	COMPLETE CHAIN W/DOGS	098987 ³	1	
	Chain	098986	1	
	CHAIN, L.15615 W/DOGS	098987 ⁴	1	
	Chain	098986	1	
	CHAIN, L.17785 W/DOGS	098812 ⁵	1	
Chain	098811	1		
16	Dog	097647-1	6-9 ⁶	
17	WASHER, M12 FLAT ZINC	F81056-1	1	
18	NUT, M12 HEX NYLON ZINC LOCK	F81034-2	1	
19	LINK, CHAIN MASTER	098661	1	
20	BRACKET, EMERGENCY SWITCH TVS	098814-1	1	
21	BOLT, M6X20MM HH FULL THREAD ZINC	F81001-2	2	
22	WASHER, M6 SPLIT LOCK ZINC	F81053-3	2	
23	WASHER, M6 FLAT ZINC	F81053-1	2	
24	SWITCH, EMERGENCY XALJ174F	E22703-P	2	
25	SCREW, M4X12-5,8-B CROSS RECESSED PAN	F81011-43	4	
26	WASHER, 4,3 FLAT ZINC	F81051-2	4	
27	GROMMET, 20/13 RUBBER	086188	2	

¹ Occurs in combination: Short Infeed + Short Outfeed.

² Occurs in combination: Short Infeed + Medium Outfeed.

³ Occurs in combination: Short Infeed + Long Outfeed.

⁴ Occurs in combination: Long Infeed + Medium Outfeed.

⁵ Occurs in combination: Long Infeed + Long Outfeed.

⁶ Dogs amount depend on chain type.

5.4 TVS Outfeed

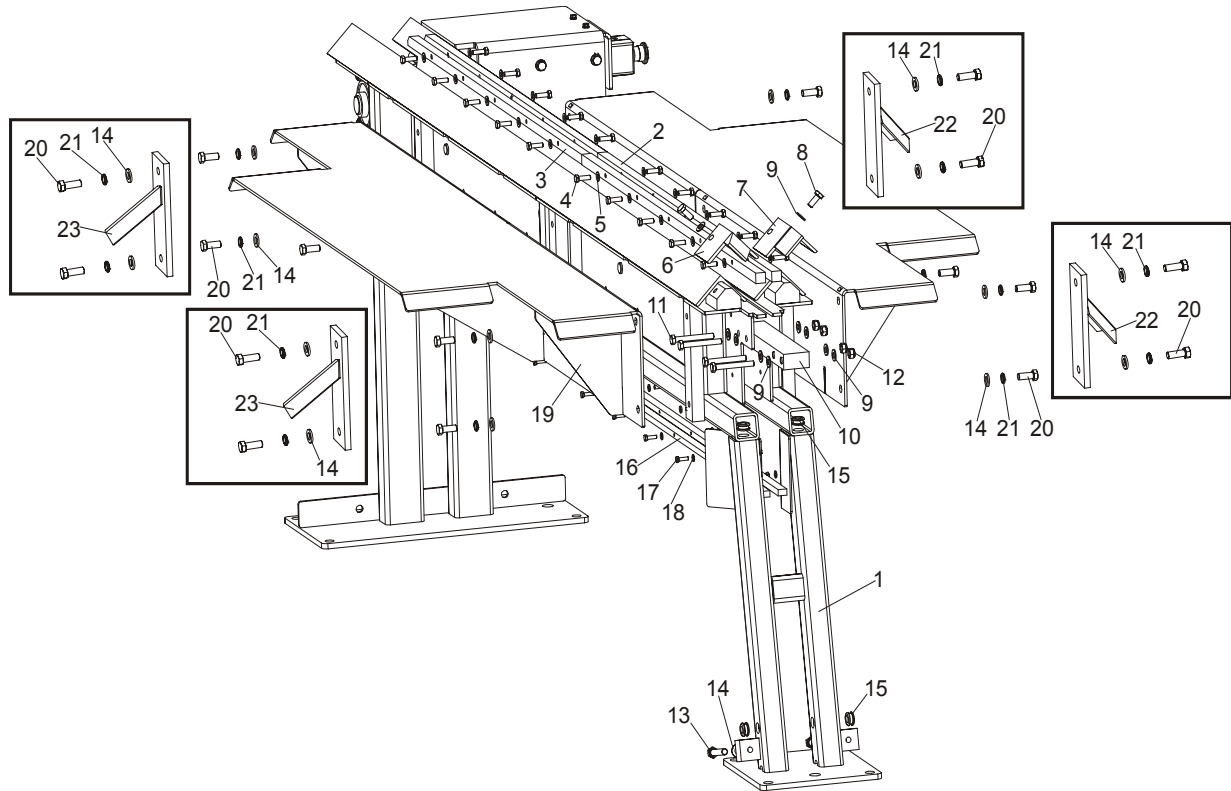

REF	DESCRIPTION (◆ Indicates Parts Available In Assemblies Only)	PART#	QTY.
	OUTFEED, TVSOV2.4I	098950	1
	OUTFEED, TVSOV2.4M	098951	1
	OUTFEED TABLE, TVS COMPLETE	097642	1
1	TABLE, TVS OUTFEED	097644-1	1
2	BAR, CHAIN SLIDE-ZINC	096199-1	2
3	BAR, CHAIN OUTER SLIDE -ZINC	098652-1	2
4	BOLT, M8 x 25mm HEX HEAD GR 5.8 ZINC	F81002-5	20
5	WASHER, M8 FLAT ZINC	F81054-1	20
6	BLOCK, GUIDE WLDMT/PTD - LEFT	098315-1	1
7	BLOCK, GUIDE WLDMT/PTD - RIGHT	098670-1	1
8	Bolt, M10-1.5x25mm HH Gr8.8	F81003-11	2
9	WASHER, M10 FLAT ZINC	F81055-1	10
10	CONNECTOR, TABLE ZINC-PLATED	098667-1	1
11	BOLT, M10x80 -8.8- HEX HEAD ZINC	F81003-50	4
12	NUT, M10 NYLON HEX ZINC LOCK	F81033-1	4
13	BOLT, M12x75-8.8-HEX HEAD ZINC	F81004-21	2
14	WASHER, M12 FLAT ZINC	F81056-1	14
15	GROMMET, 20/13 RUBBER	086188	4
16	BAR, CHAIN SUPPORT	098942-1	4
17	BOLT, M6X20MM HH FULL THREAD ZINC	F81001-2	20
18	WASHER, M6 FLAT ZINC	F81053-1	20

19	TABLE, SIDE PTD	097932-1	2	
20	BOLT, M12x30-8.8	F81004-22	8/12 ¹	
21	WASHER, M12 SPLIT LOCK ZINC	F81056-2	8/12 ¹	
22	ANGLE, BOARD REMOVAL LEFT	097885-1 ²	2	
23	ANGLE, BOARD REMOVAL RIGHT	097886-1 ²	2	
	OUTFEED, TVSOV3.6I	098952	1	
	OUTFEED, TVSOV3.6M	098953	1	
	OUTFEED, MEDIUM COMPLETE	098755	1	
1	OUTFEED, TVS MEDIUM	098754-1	1	
2	BAR, CHAIN SLIDE - ZINC	096199-1	2	
3	BAR, CHAIN OUTER SLIDE - ZINC	098652-1	2	
	BAR, CHAIN SHORT SLIDE- ZINC	098753-1	2	
4	BOLT, M8 x 25mm HEX HEAD GR 5.8 ZINC	F81002-5	28	
5	WASHER, M8 FLAT ZINC	F81054-1	28	
6	BLOCK, GUIDE WLDMT/PTD - LEFT	098315-1	1	
7	BLOCK, GUIDE WLDMT/PTD - RIGHT	098670-1	1	
8	Bolt, M10-1.5x25mm HH Gr8.8	F81003-11	2	
9	WASHER, FLAT, M10, ZINC	F81055-1	10	
10	CONNECTOR, TABLE ZINC-PLATED	098667-1	1	
11	BOLT, M10x80 -8.8- HEX HEAD ZINC	F81003-50	4	
12	NUT, M10, NYLON HEX ZINC LOCK	F81033-1	4	
13	BOLT, M12x75-8.8-HEX HEAD ZINC	F81004-21	2	
14	WASHER, M12 FLAT ZINC	F81056-1	14	
15	GROMMET, 20/13 RUBBER	086188	4	
16	BAR, CHAIN SUPPORT	098942-1	4	
	BAR, CHAIN SHORT SUPPORT	098943-1	2	
17	BOLT, M6X20MM, HH, FULL THREAD, ZINC	F81001-2	28	
18	WASHER, M6 FLAT ZINC	F81053-1	28	
19	TABLE, SIDE	097932-1	2	
20	BOLT M12x30-8.8	F81004-22	8/12 ¹	
21	WASHER, M12 SPLIT LOCK ZINC	F81056-2	8/12 ¹	
22	ANGLE, BOARD REMOVAL LEFT	097885-1 ²	2	
23	ANGLE, BOARD REMOVAL RIGHT	097886-1 ²	2	
	OUTFEED, TVSOV4.8I	098954	1	
	OUTFEED, TVSOV4.8M	098955	1	
	OUTFEED, TVS LONG COMPLETE	098796	1	
1	OUTFEED, TVS	098795-1	1	
2	BAR, CHAIN SLIDE -ZINC	096199-1	4	
3	BAR, CHAIN OUTER SLIDE -ZINC	098652-1	2	
	BAR, CHAIN SHORT SLIDE -ZINC	098753-1	2	
4	BOLT, M8 x 25mm HEX HEAD GR 5.8 ZINC	F81002-5	36	
5	WASHER, M8 FLAT ZINC	F81054-1	36	
6	BLOCK, GUIDE WLDMT/PTD - LEFT	098315-1	1	
7	BLOCK, GUIDE WLDMT/PTD - RIGHT	098670-1	1	
8	Bolt, M10-1.5x25mm HH Gr8.8	F81003-11	2	
9	WASHER, M10 FLAT ZINC	F81055-1	10	

10	CONNECTOR, TABLE ZINC-PLATED	098667-1	1	
11	BOLT, M10x80 -8.8-HEX HEAD ZINC	F81003-50	4	
12	NUT, M10 NYLON HEX ZINC LOCK	F81033-1	4	
13	BOLT, M12x75-8.8-HEX HEAD ZINC	F81004-21	2	
14	WASHER, M12 FLAT ZINC	F81056-1	14	
15	GROMMET, 20/13 RUBBER	086188	4	
16	BAR, CHAIN SUPPORT	098942-1	6	
	BAR, CHAIN SUPPORT SHORT	098943-1	2	
17	BOLT, M6X20MM HH FULL THREAD ZINC	F81001-2	38	
18	WASHER, M6 FLAT ZINC	F81053-1	38	
19	TABLE, SIDE PTD	097932-1	4	
20	BOLT M12x30-8.8	F81004-22	16/24 ¹	
21	WASHER, M12 SPLIT LOCK ZINC	F81056-2	16/24 ¹	
22	ANGLE, BOARD REMOVAL LEFT	097885-1 ²	4	
23	ANGLE, BOARD REMOVAL RIGHT	097886-1 ²	4	

¹ First number of the fasteners concerns I-version table (in line), second concerns M-version table (manual).

² Only in I-version table (in line).

5 Infeed & Outfeed Tables

Tables Decals

5.5 Tables Decals

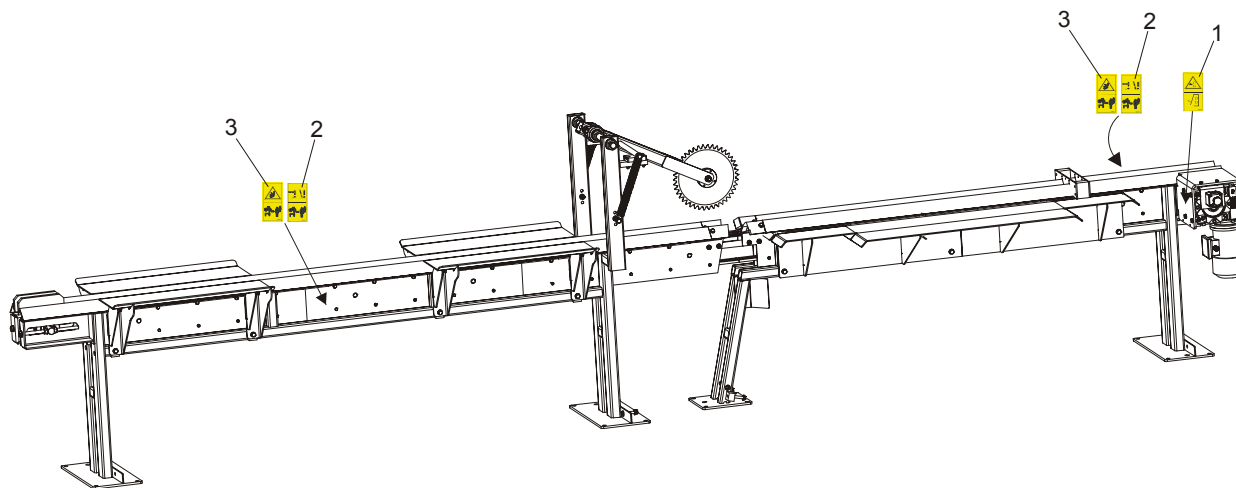

REF	DESCRIPTION (◆ Indicates Parts Available In Assemblies Only)	PART#	QTY.
	DECALS KIT, PICTOGRAMS, INFEE&OUTFEED TABLES	099580	1
1	Decal, Close guards prior to operating the machine	099220	1
2	Decal, keep all persons a safe distance	096314	2
3	Decal, keep a safe distance	099221	2

SECTION 6 INCLINE LOG DECK

6.1 Infeed Assembly

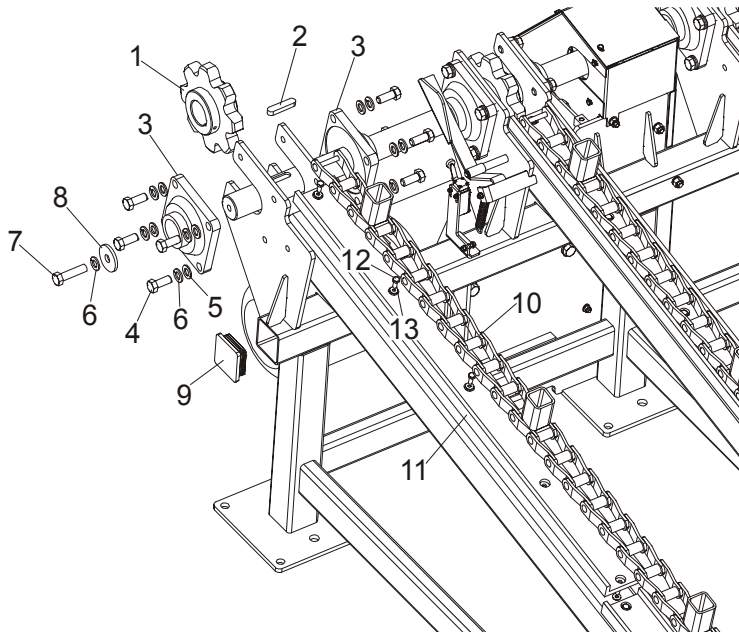

TVS_039

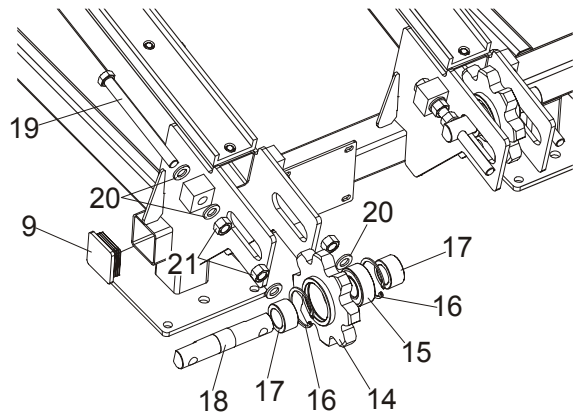

REF	DESCRIPTION (◆ Indicates Parts Available In Assemblies Only)	PART #	QTY.
	TVS INCLINE LOG DECK	097999	1
1	SPROCKET, Z8 OXIDIZED	089888-1	4
2	KEY, A16X10X70 PARALLEL	098029	4
3	BEARING, UCF 211W/HOUSING (55 DIA. SHAFT)	089889	8
4	BOLT, M16x40-8.8 HEX HEAD FULL THREAD ZINC	F81006-13	32
5	WASHER, 17 FLAT ZINC	F81058-1	32
6	WASHER, 16.3 SPLIT LOCK ZINC	F81058-2	32
7	BOLT, M16x65-8.8-B HEX HEAD FULL THREAD ZINC	F81006-1	4
8	WASHER, TVS SPECIAL	098012-1	2

6**Incline Log Deck***Infeed Assembly*

9	CAP, FRAME TUBE	089644	4	
10	CHAIN, TVS INCLINE LOG DECK	098479-1	4	
11	CHANNEL, UHMW CONVEYOR	033722	8	
12	BOLT, M8x20-5.8 HEX HEAD FULL THREAD ZINC	F81002-1	40	
13	WASHER, 6.5 SPECIAL FLAT ZINC	F81053-11	40	
14	SPROCKET, Z8 REAR OXIDIZED	089919-1	4	
15	BEARING, 3208B.2RSR.TVH FAG	088449	4	
16	RING, W80 INSIDE RETAINING	F81090-25	8	
17	BUSHING, SPROCKET SPACER	089916-1	8	
18	SHAFT, CHAIN TENSION SPROCKET	089915-1	4	
19	BOLT, M20x240-8.8 HEX HEAD FULL THREAD ZINC	F81007-1	8	
20	WASHER, 21 FLAT ZINC	F81059-2	24	
21	NUT, M20-8 HEX ZINC	F81037-1	16	

6.2 Limit Switch Assembly

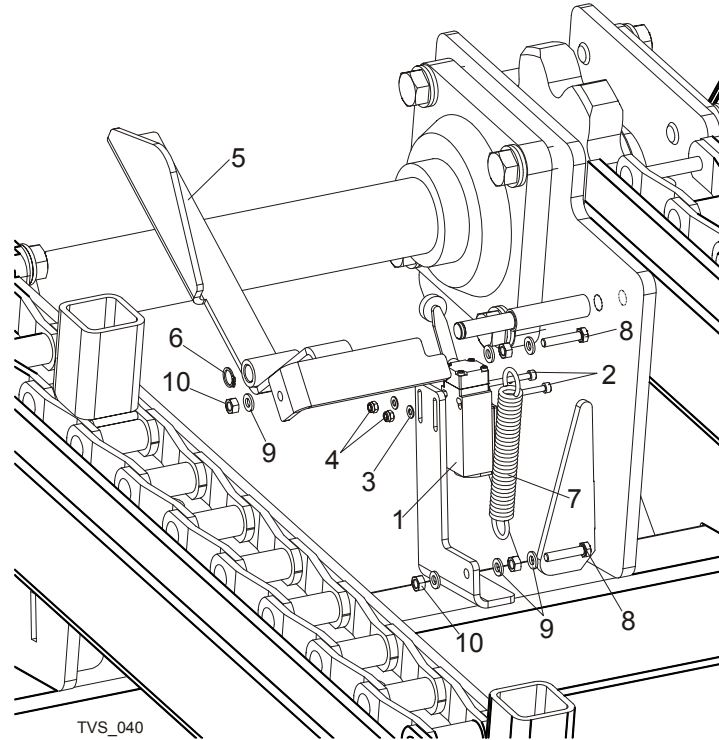

REF	DESCRIPTION (◆ Indicates Parts Available In Assemblies Only)	PART #	QTY.
1	LIMIT SWITCH, GLCB01A2B	086469	1
2	SCREW, M4X35-8.8 HEX SOCKET HEAD CAP ZINC	F81011-34	2
3	WASHER, 4.3 FLAT ZINC	F81051-2	2
4	NUT, M4-B HEX NYLON LOCK ZINC	F81029-1	2
5	ARM, TVS LIMIT SWITCH ACTIVATOR - COMPLETE	098474-1	1
6	RING, Z12 OUTSIDE RETAINING	F81090-14	1
7	SPRING, FI 1.9 X FI 14.2 X 104	091865	1
8	BOLT, M6X30 5.8 HEX HEAD FULL THREAD	F81001-13	2
9	WASHER, 6.4 FLAT ZINC	F81053-1	6
10	NUT, M6-8 HEX ZINC	F81031-1	4

6.3 Drive Assembly

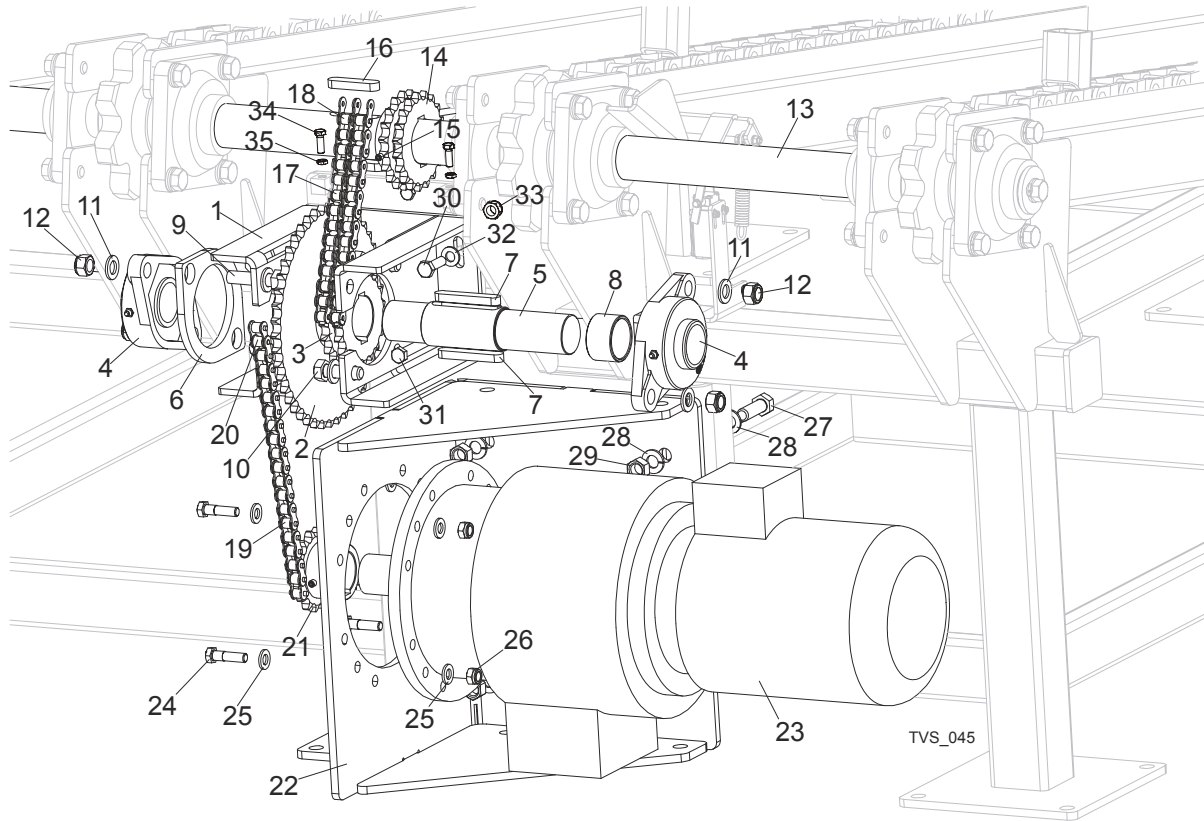

REF	DESCRIPTION (◆ Indicates Parts Available In Assemblies Only)	PART #	QTY.
	GEAR ASSEMBLY, TVS INCLINE LOG DECK	098424	1
1	BRACKET WELDMENT, TVS SPROCKET MOUNTING	098422-1	1
2	SPROCKET, 12B Z45 OXIDIZED	089894-1	1
3	SPROCKET, 12B Z19	098013-1	1
4	BEARING, UCFL 210 CX W/HOUSING	098824	2
5	SHAFT, INTERMEDIATE SPROCKET ZINC-PLATED	098419-1	1
6	PLATE, FL 210 BEARING SPACER	099106-1	1
7	KEY, A16X10X90 PARALLEL	099131	2
8	SPACER, TVS SPROCKET	098011-1	1
9	BOLT, M16	099647	2
10	BOLT, M16x50-8.8 HEX HEAD FULL THREAD ZINC	F81006-7	2
11	WASHER, 17 FLAT ZINC	F81058-1	8
12	NUT, M16-8 HEX NYLON LOCK ZINC	F81036-2	4
13	SHAFT, TVS INCLINE LOG DECK MAIN	098010	1
14	SPROCKET, 12B Z19	098013-1	1
15	SCREW, M8X8-33H HEX SOCKET SET FLAT POINT ZINC	F81014-1	4
16	KEY, A16X10X70 PARALLEL	098029	2
17	CHAIN, 12B-2-41 (0.8 RM)	099250	1
18	LINK, 12B-1PZ CHAIN	099249	1

19	CHAIN, 12B-1-65 (1.25 RM)	099248	1	
20	LINK, 12B-1PZ CHAIN	090713	1	
21	SPROCKET, 12B Z16 OXIDIZED	090303-1	1	
22	BRACKET WELDMENT, DECK MOTOR MOUNT	089897-1	1	
23	MOTOREDUCER, SBCM 180/112M-4/32	089892	1	
24	BOLT, M12X45-8.8 HEX HEAD ZINC	F81004-32	4	
25	WASHER, 13 FLAT ZINC	F81056-1	8	
26	NUT, M12-8 HEX NYLON LOCK ZINC	F81034-2	4	
27	BOLT, M16X50-8.8 HEX HEAD FULL THREAD ZINC	F81006-7	4	
28	WASHER, 17 FLAT ZINC	F81058-1	8	
29	NUT, M16-5.8 HEX ZINC	F81036-1	4	
30	BOLT, M12X40-8.8 HEX HEAD FULL THREAD ZINC	F81004-4	2	
31	BOLT, M12X120 8.8 HEX HEAD ZINC	F81004-38	2	
32	WASHER, 13 FLAT ZINC	F81056-1	8	
33	NUT, M12-8-B HEX ZINC	F81034-1	4	
34	BOLT, M10X50MM,HEX HEAD FULL THRD ZINC	F81003-4	2	
35	NUT, M10-8-B-FE	F81033-3		

6.4 Chain Guards

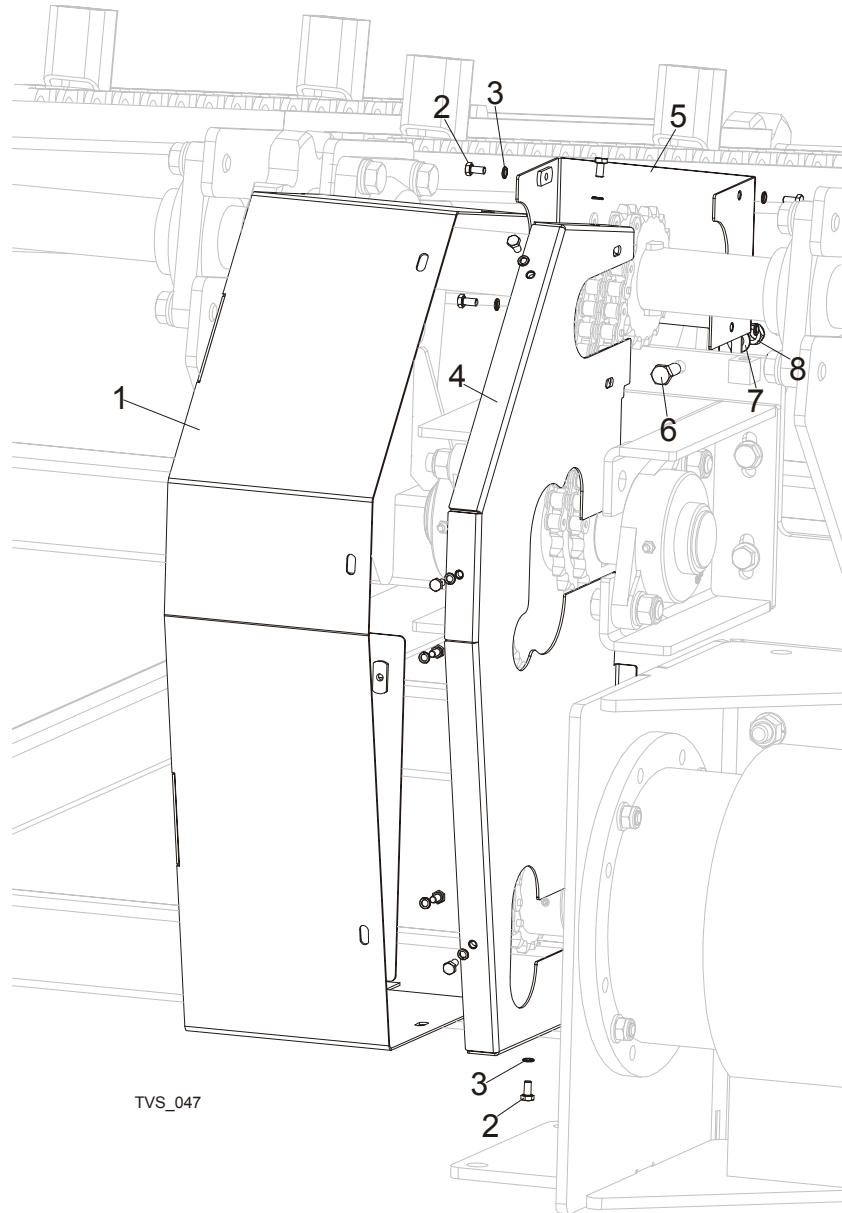

REF	DESCRIPTION (◆ Indicates Parts Available In Assemblies Only)	PART #	QTY.
1	GUARD, TVS ILD GEAR - MAIN	098467-1	1
2	BOLT, M6X12-8.8 HEX HEAD FULL THREAD ZINC	F81001-7	11
3	WASHER, Z 6.1 SPLIT LOCK ZINC	F81053-3	11
4	GUARD, TVS ILD GEAR - SIDE	098470-1	1
5	GUARD, TVS REAR	098469-1	1
6	BOLT, M10X30-5.8 HEX HEAD FULL THREAD ZINC	F81003-2	1
7	WASHER, 10.5 FLAT ZINC	F81055-1	1
8	NUT, M10-8-B HEX NYLON LOCK ZINC	F81033-1	1

6.5 Decals

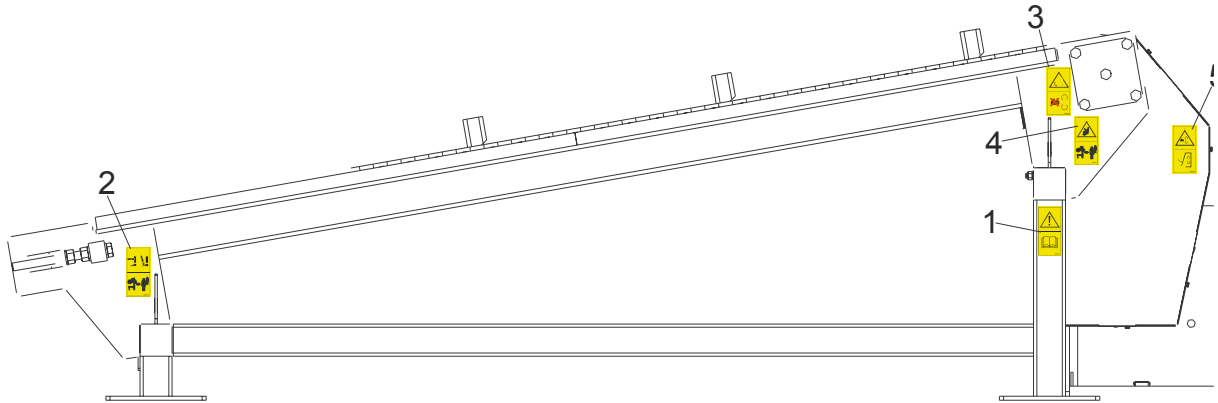

TVS_048

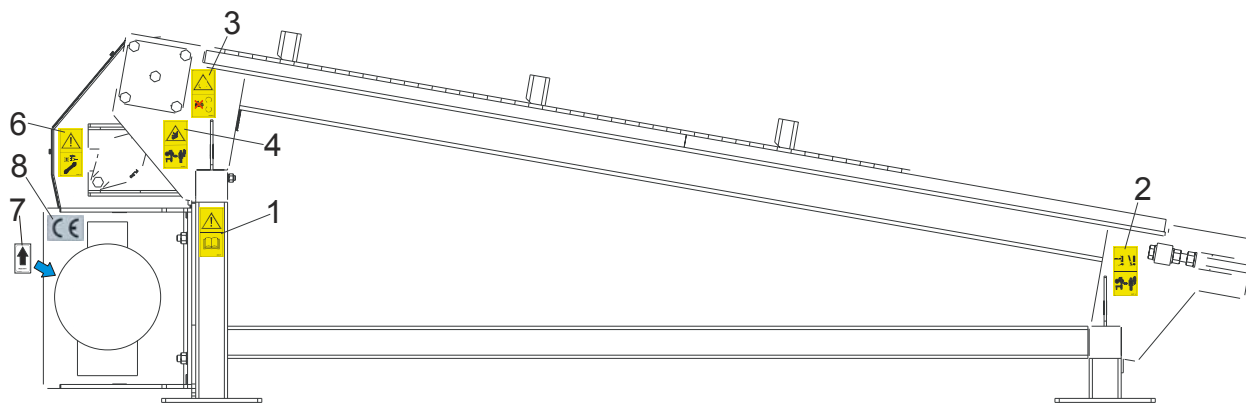

REF	DESCRIPTION (◆ Indicates Parts Available In Assemblies Only)	PART #	QTY.
	DECALS KIT, PICTOGRAMS, INCLINE LOG DECK	099579	1
1	Decal, read operator's manual (pictogram)	096317	2
2	Decal, keep away warning (pictogram)	096314	2
3	Decal, gear danger (pictogram)	099540	2
4	Decay, keep away warning (pictogram)	099221	2
5	Decal, close all guards and covers before starting the machine	099220	1
6	Decal, disconnect and lock out power supply before servicing (pictogram)	098177	1
7	Decal, 1400 RPM Motor Direction	S20097H	1
8	DECAL, CE - CERTIFIED SAWMILL	P85070	1

SECTION 7 CROSS TRANSFER DECK

7.1 Front Module & Chains

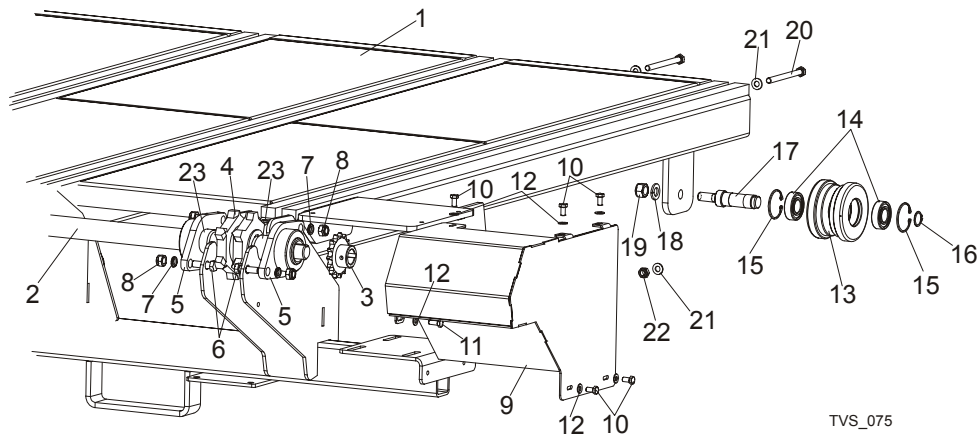

REF	DESCRIPTION (◆ Indicates Parts Available In Assemblies Only)	PART #	QTY.
	COMPLETE FRONT MODULE	099556	1
1	FRAME WELDMENT, CTD FRONT	097899-1	1
2	SHAFT, CTD DRIVE	097893	1
3	SPROCKET, 10B Z 15 INCLINE CONVEYOR	095162	1
4	SPROCKET, 16B 20Z	097657	4
5	BEARING, FYTB 40 KG	097898	8
6	BOLT, M12x40-8.8 HEX HEAD ZINC	F81004-1	16
7	WASHER, M12 SPLIT LOCK ZINC	F81056-2	16
8	NUT, M12-8 HEX NYLON ZINC LOCK	F81034-2	16
9	COVER, CTD CHAIN	097903-1	1
10	BOLT, M8x16-8.8 HEX HEAD ZINC	F81002-20	5
11	BOLT, M8X20-8.8-B HEX HEAD FULL THREAD ZINC	F81002-4	1
12	WASHER, 8.4 FLAT, ZINC	F81054-1	6
	WHEEL, CTD COMPLETE	098492	4
13	TENSIONER, CTD CHAIN	098493	1
14	BEARING, SKF 6205-2RS ROLLER	087353	2
15	RING, W52 INSIDE RETAINING	F81090-6	2
16	RING, 25Z OUTSIDE RETAINING	F81090-22	1
17	SHAFT, CTD CHAIN TENSIONER	098494	1
18	WASHER, 16.3 SPLIT LOCK ZINC	F81058-2	4
19	NUT, M16-8 HEX NYLON ZINC LOCK	F81036-2	4
20	BOLT, M10x125-8.8 HEX HEAD ZINC	F81003-18	6
21	WASHER, 10.5 FLAT ZINC	F81055-1	12
22	NUT, M10-8-B HEX NYLON ZINC LOCK	F81033-1	6
23	BUSHING, FI 40 x FI 48x14 SPACER	099958-1	8
	CHAIN, SLPCTD3.6 ZINC-PLATED	099310	4
	CHAIN, SLPCTD5.4	099571	4
	CHAIN, CTC7.2	099572	4

7.2 Central Module

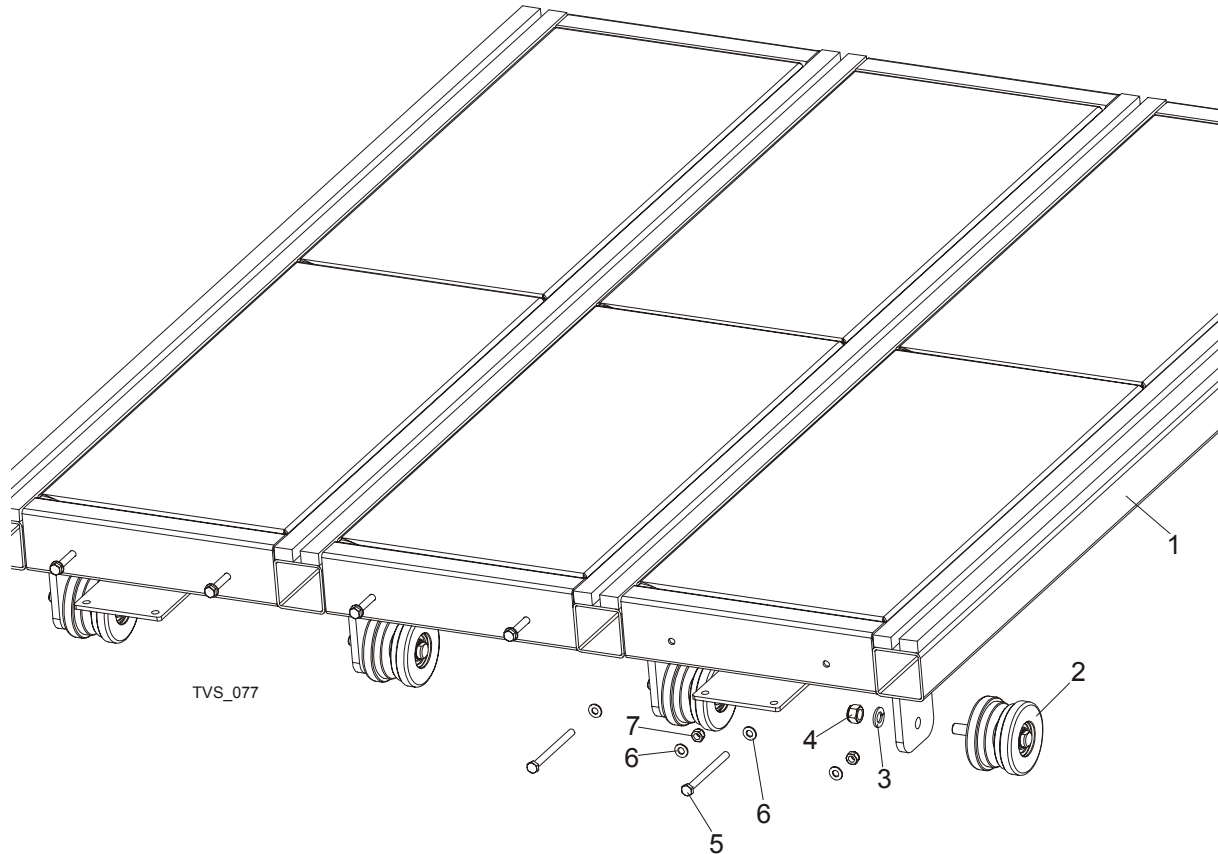

REF	DESCRIPTION (◆ Indicates Parts Available In Assemblies Only)	PART #	QTY.
	COMPLETE CENTRAL MODULE	099557	1/2 ¹
1	MODULE, CTD CENTRAL PAINTED	098125-1	1
2	WHEEL, CTD COMPLETE	098492	4
3	WASHER, 16.3 SPLIT LOCK ZINC	F81058-2	4
4	NUT, M16-8 HEX NYLON ZINC LOCK	F81036-2	4
5	BOLT, M10x125-8.8 HEX HEAD ZINC	F81003-18	6
6	WASHER, 10.5 FLAT ZINC	F81055-1	12
7	NUT, M10-8-B HEX NYLON ZINC LOCK	F81033-1	6

¹ Used on CTD5.4 - 1 piece and on CTD7.2 - 2 pieces.

7 CROSS TRANSFER DECK

Rear Module

7.3 Rear Module

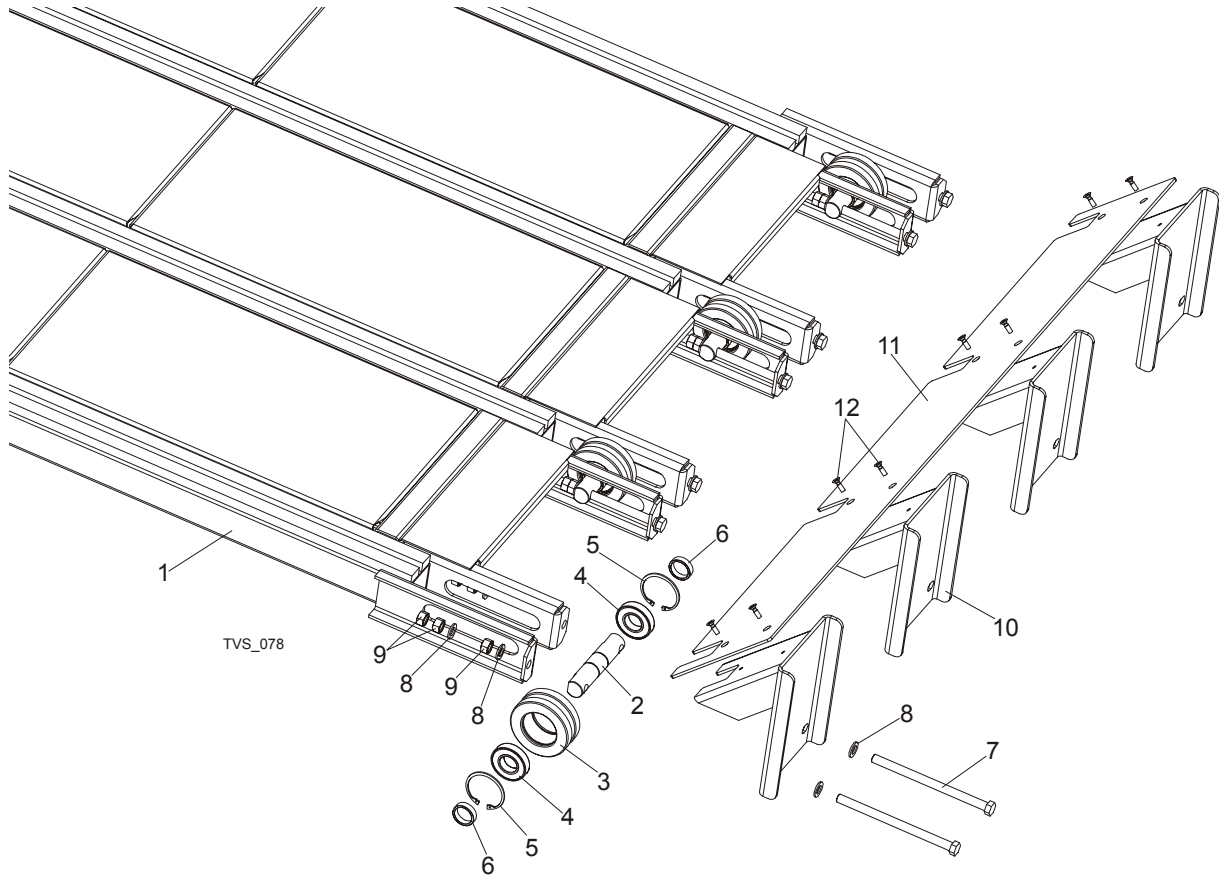

REF	DESCRIPTION (◆ Indicates Parts Available In Assemblies Only)	PART #	QTY.
	COMPLETE REAR MODULE	099558	1
1	FRAME WELDMENT, CTD REAR PTD	097900-1	1
	COMPLETE CHAIN TENSION WHEEL	097655	4
2	SHAFT, CHAIN TENSION WHEEL	096207-1	1
3	WHEEL, TVS CHAIN TENSION	096208-1	1
4	BEARING, 6207-2RS, C3, 35X72X17	014811	2
5	RING, W72 INSIDE RETAINING	F81090-4	2
6	BUSHING, FI 36x FI 44x22 SPACER ZINC	099959-1	8
7	BOLT, M16X240-8.8-A2 FULL THREAD	F81006-29	8
8	WASHER, 17 FLAT ZINC	F81058-1	24
9	NUT, M16-5.8 HEX ZINC	F81036-1	24
	BUMPER ASSEMBLY	099560-1	1
10	BRACKET, BUMPER MOUNTING	098223-1	4
11	PLATE, CTD BUMPER	098496-1	1
12	SCREW, M8X25 CROSS RECESSED COUNTERSUNK HEAD	F81002-51	8

7.4 Cross Transfer Deck Drive

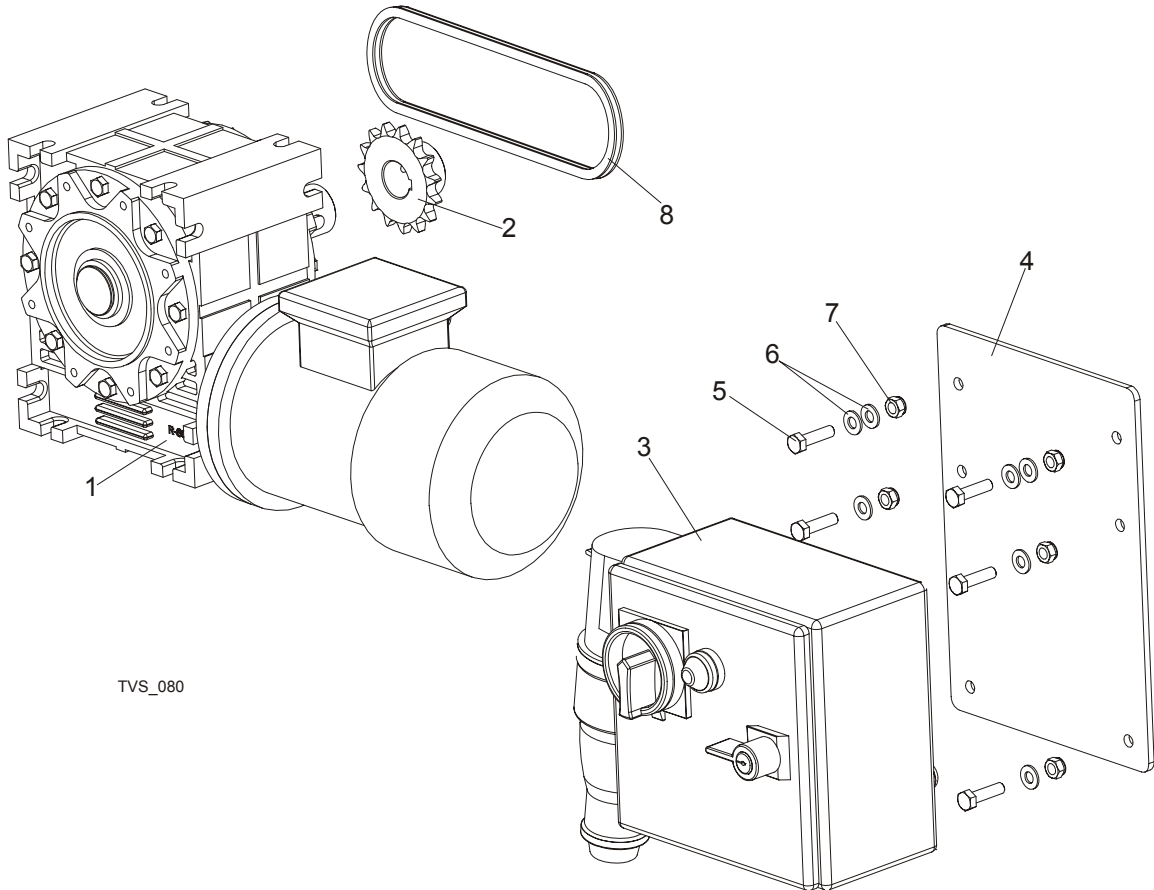

REF	DESCRIPTION (◆ Indicates Parts Available In Assemblies Only)	PART #	QTY.
	MOTOR KIT	099559	1
1	MOTOREDUCER, MR-80/64-1.1-1400/K3/V6	098663	1
2	SPROCKET, 10B Z 15 INCLINE CONVEYOR	095162	1
3	BOX, CTD ELECTRIC	098826	1
4	PANEL, CTD ELECTRIC BOX	099550-1	1
5	BOLT, M8X30-5.8 HEX HEAD FULL THREAD ZINC	F81002-2	6
6	WASHER, 8.4 FLAT ZINC	F81054-1	8
7	NUT, M8-8-B HEX NYLON ZINC LOCK	F81032-2	6
8	CHAIN, 10B-48PZ	099781	1

7.5 Leg Kits

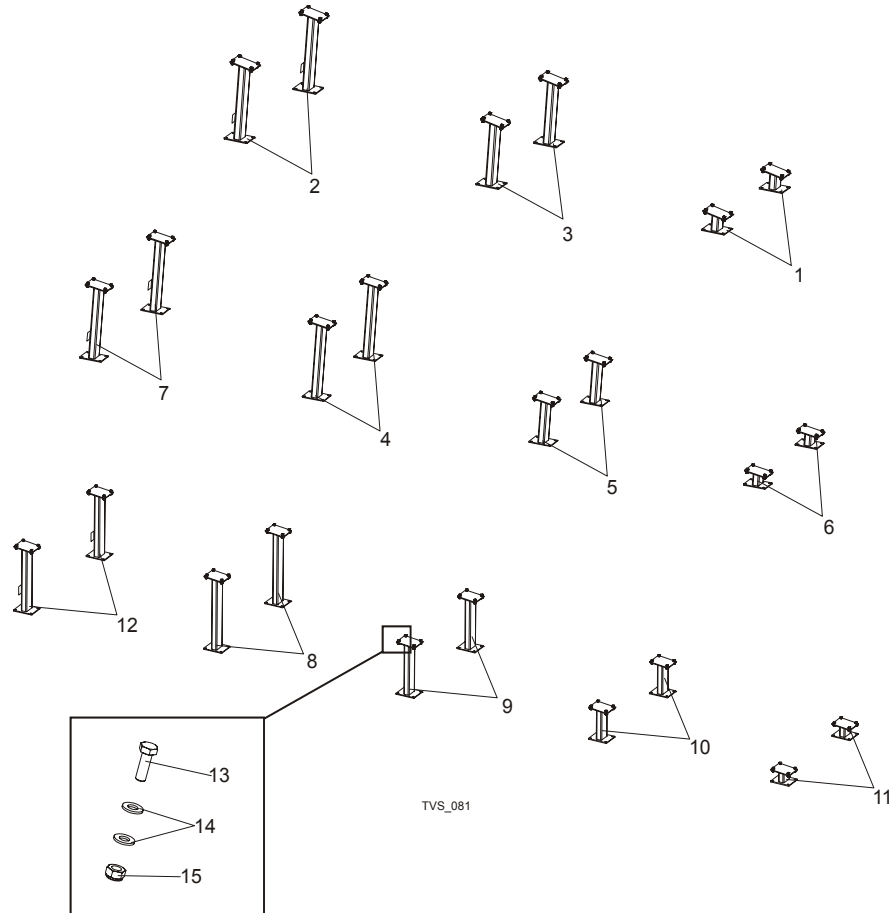

REF	DESCRIPTION (◆ Indicates Parts Available In Assemblies Only)	PART #	QTY.	
	LEG KIT, CTD SHORT	099554	1	
1	LEG, 7.6M REAR PTD	099279-1	2	
2	LEG, FRONT PTD	099415-1	2	
3	LEG, REAR PTD	099416-1	2	
	LEG KIT, CTD MEDIUM	099568	1	
4	LEG, CTD5.4 MIDDLE PTD (1)	099573-1	2	
5	LEG, CTD5.4 MIDDLE PTD (2)	099574-1	2	
6	LEG, CTD5.4 REAR PTD	099575-1	2	
7	LEG, CTD5.4 FRONT PTD	099576-1	2	
	LEG KIT, CTD LONG	099553	1	
8	LEG, CTD7.2 MIDDLE PTD (1)	099277-1	2	
9	LEG, CTD7.2 MIDDLE PTD (2)	099278-1	2	
10	LEG, CTD7.2 MIDDLE PTD (3)	099562-1	2	
11	LEG, CTD7.2 REAR PTD	099564-1	2	
12	LEG, CTD7.2 FRONT PTD	099566-1	2	
13	BOLT, M10x30-5.8 HEX HEAD FULL THREAD ZINC	F81003-2	24/32/40	
14	WASHER, 10.5 FLAT ZINC	F81055-1	48/64/80	
15	NUT, M10-8-B HEX NYLON ZINC LOCK	F81033-1	24/32/40	

7.6 Slabs Table

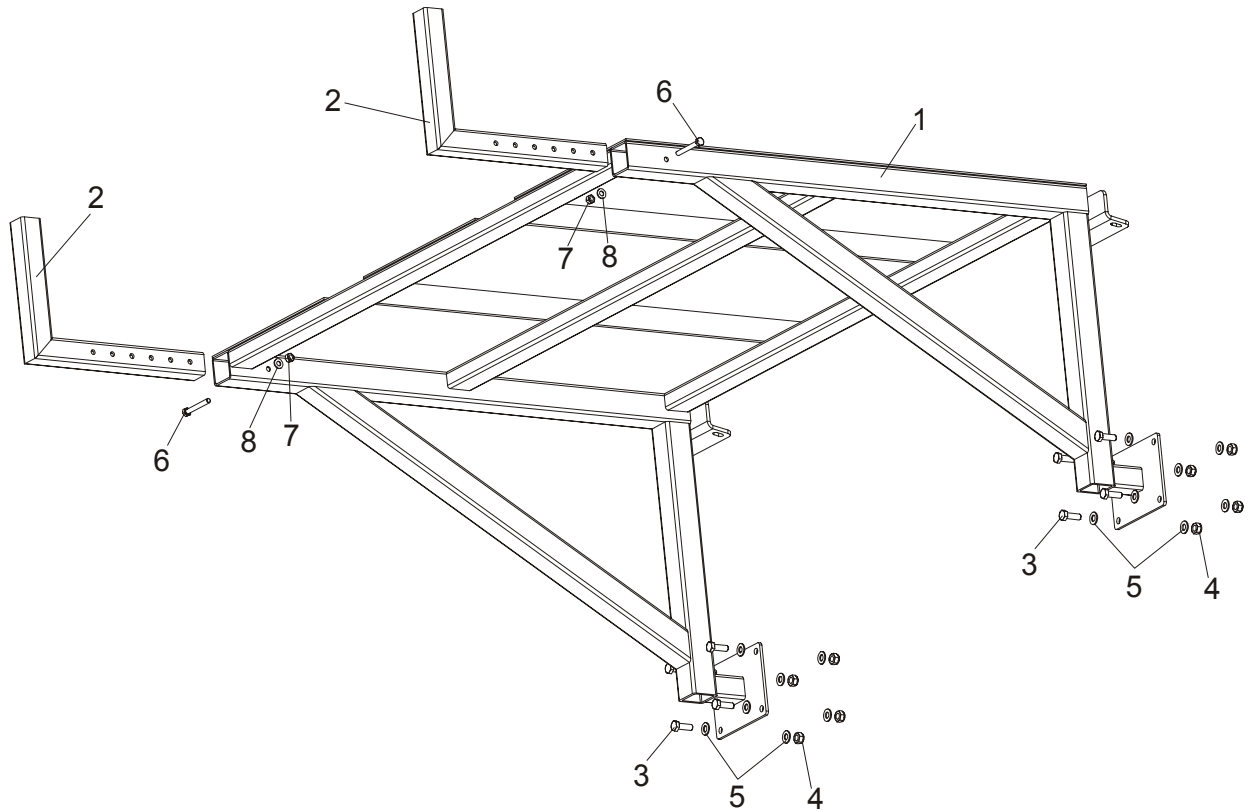

REF	DESCRIPTION (◆ Indicates Parts Available In Assemblies Only)	PART #	QTY.
1	TABLE, SLPCTD HIGH	100517-1	1
2	ARM, TABLE LOCK	100531-1	2
3	BOLT, M10X30-5.8 HEX HEAD FULL THREAT	F81003-2	8
4	NUT, M10-8-B NYLON HEX ZINC LOCK	F81033-1	16
5	WASHER, 10.5 FLAT ZINC	F81055-1	8
6	BOLT, M8X65 8.8 HEX HEAD ZINC	F81002-9	2
7	NUT, M8 HEXAGON, GRADE 5.8 FREE ZINC	F81032-1	2
8	WASHER, 8.4 FLAT ZINC	F81054-1	2

7 CROSS TRANSFER DECK

Decals

7.7 Decals

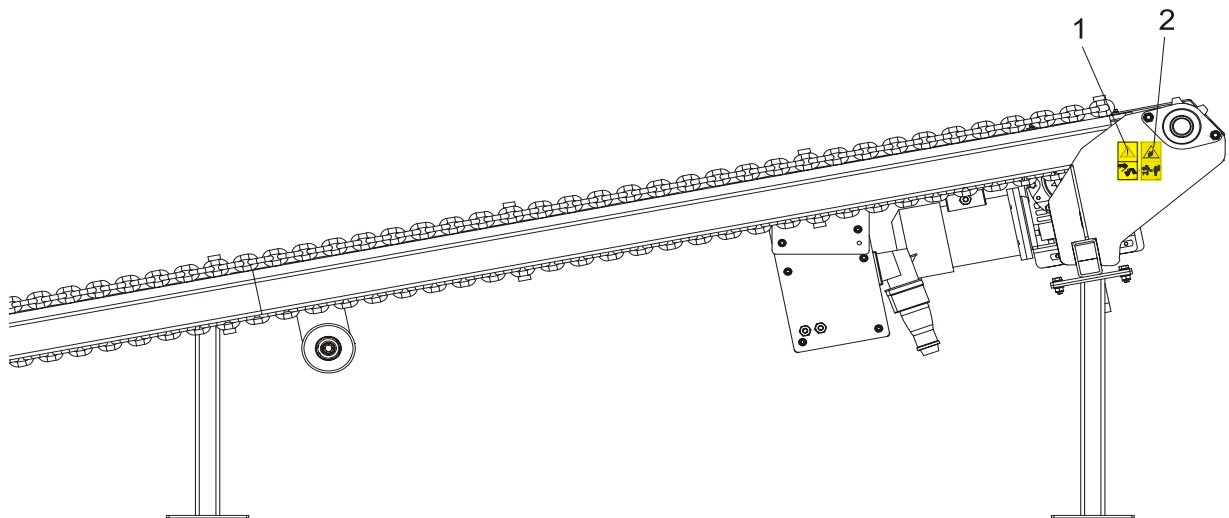
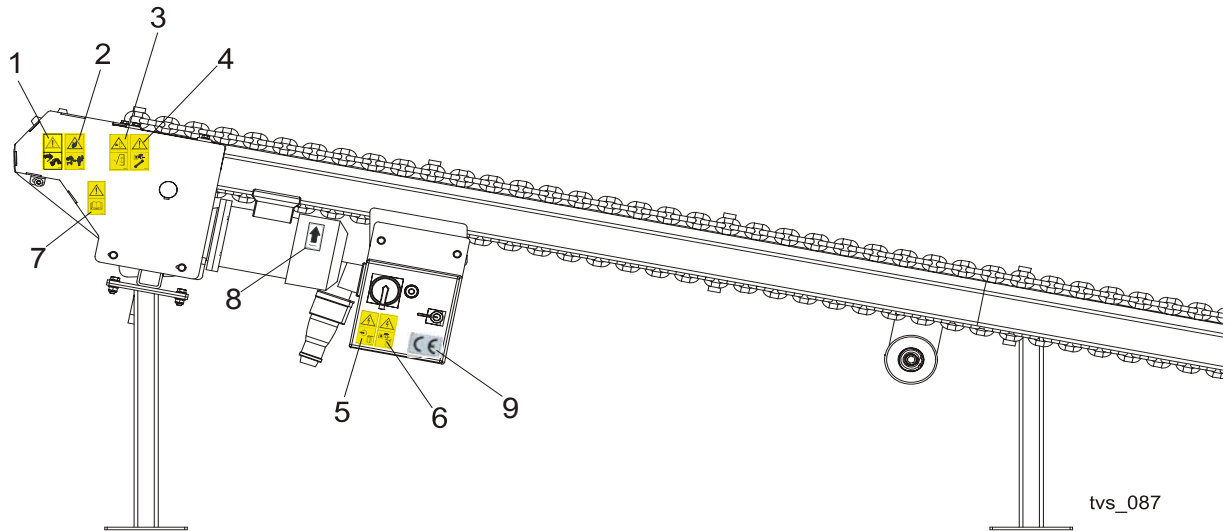

REF	DESCRIPTION (◆ Indicates Parts Available In Assemblies Only)	PART #	QTY.
	DECALS KIT, PICTOGRAMS, CROSS TRANSFER DECK	099835	1
1	Decal, look out for the falling slabs (pictogram)	099780	2
2	Decay, keep away warning (pictogram),	099221	2
3	Decal, close all guards and covers before starting the machine	099220	1
4	Decal, disconnect and lock out power supply before servicing (pictogram)	098177	1
5	Decal, high voltage inside the electric box (pictogram)	096316	1
6	Decal, remove the plug before opening the box (pictogram)	096319	1
7	Decal, read operator's manual (pictogram)	096317	1
8	Decal, 1400 RPM Motor Direction	S20097H	1
9	DECAL, CE - CERTIFIED SAWMILL	P85070	1