

Wood-Mizer®

Twin Vertical Saw

Parts Manual

TVSE11S
TVSE15S

rev.A8.03
rev.A8.03



Safety is our #1 concern! Read and understand all safety information and instructions before operating, setting up or maintaining this machine.

August 2007

Form #1004

Table of Contents

Section-Page

SECTION 1	GENERAL INFORMATION	1-1
1.1	How To Use The Parts List	1-1
1.2	Sample Assembly	1-1
SECTION 2	BLADE GUIDE ROLLERS & ARM	2-1
2.1	Blade Guide Assembly, Idle Side.....	2-1
2.2	Blade Guide Assembly, Drive Side.....	2-3
SECTION 3	BLADE WHEELS & TENSIONER	3-1
3.1	Blade Wheel Assembly, Drive Side	3-1
3.2	Blade Wheel Assembly, Idle Side.....	3-2
3.3	Blade Tensioner Assembly.....	3-3
3.4	Blade Tensioner Pump Assembly	3-5
SECTION 4	SAW HEAD	4-1
4.1	Middle Throat Screw.....	4-1
4.2	Water Lube Assembly (LMS)	4-2
4.3	Saw Head Decals.....	4-4
4.4	Blade Housing Cover	4-5
4.5	Cutting Width Manual Setting Assembly.....	4-7
4.6	Cutting Width Automatic Setting Assembly	4-9
4.7	Saw Head Width Indicator	4-12
4.8	Saw Head Slide Brackets.....	4-13
4.9	Hold-Down Roller (V-tables).....	4-14
4.10	Saw Head Hold-Down Roller (Spiky Chain Table)	4-16
4.11	Hold-Down Roller Assembly (Option)	4-17
4.12	Blade Drive Motor.....	4-19
4.13	Saw Head Support Rollers.....	4-20
4.14	Electric Box.....	4-22
4.15	Control Box	4-23
4.16	Laser Assembly (Optional)	4-25
4.17	Friction Assembly (Manual Cutting Width Setting)	4-26
SECTION 5	INFEED & OUTFEED TABLES	5-1
5.1	TVS Infeed	5-1
5.2	Infeed table chain tension wheel	5-5
5.3	Chain Drive Assembly, TVS.....	5-6
5.4	Chain Drive Assembly, “Heavy Duty” Option	5-8
5.5	TVS Outfeed.....	5-9
5.6	Additional Hold-Down Roller Kit	5-12
5.7	Tables Decals.....	5-14

Table of Contents

Section-Page

SECTION 6	INCLINE LOG DECK	6-1
6.1	Infeed Assembly	6-1
6.2	Additional Grid, Option For TVS Incline Log Deck	6-2
6.3	Limit Switch Assembly	6-3
6.4	Drive Assembly	6-4
6.5	Chain Guards	6-6
6.6	LD4 Leg Foot Plate	6-7
6.7	LD4 Log Rest Table	6-8
6.8	LD4 Shut-Off Lever Assembly	6-9
6.9	Decals	6-10
SECTION 7	CROSS TRANSFER DECK	7-1
7.1	Front Module & Chains	7-1
7.2	Central Module	7-2
7.3	Rear Module	7-3
7.4	Cross Transfer Deck Drive	7-4
7.5	Leg Kits	7-5
7.6	Slabs Table	7-6
7.7	Decals	7-7

SECTION 1 GENERAL INFORMATION

1.1 How To Use The Parts List

- Use the index above to locate the assembly that contains the part you need.
- Go to the appropriate section and locate the part in the illustration.
- Use the number pointing to the part to locate the correct part number and description in the table.
- Parts shown indented under another part are included with that part.
- Parts marked with a diamond (◆) are only available in the assembly listed above the part.

See the sample table below. Sample Part #A01111 includes part F02222-2 and subassembly A03333. Subassembly A03333 includes part S04444-4 and subassembly K05555. The diamond (◆) indicates that S04444-4 is not available except in subassembly A03333. Subassembly K05555 includes parts M06666 and F07777-77. The diamond (◆) indicates M06666 is not available except in subassembly K05555.

1.2 Sample Assembly				
REF	DESCRIPTION (◆ Indicates Parts Available In Assemblies Only)	PART #	QTY.	
	Sample Assembly, Complete (Includes All Indented Parts Below)	A01111	1	
1	Sample Part	F02222-22	1	
	Sample Subassembly (Includes All Indented Parts Below)	A03333	1	
2	Sample Part (◆ Indicates Part Is Only Available With A03333)	S04444-4	1	◆
	Sample Subassembly (Includes All Indented Parts Below)	K05555	1	
3	Sample Part (◆ Indicates Part Is Only Available With K05555)	M06666	2	◆
4	Sample Part	F07777-77	1	

To Order Parts:

- From Europe call our European Headquarters and Manufacturing Facility in Kolo, Poland at **+48-63-2626000**. From the continental U.S., call our toll-free Parts hotline at **1-800-525-8100**. Have your customer number, vehicle identification number, and part numbers ready when you call. From other international locations, contact the Wood-Mizer distributor in your area for parts.

Office Hours:

Country	Monday - Friday	Saturday	Sunday
Poland	7-15	Closed	Closed
US	8 a.m.- 5 a.m.	8 a.m.- 12 p.m.	Closed



CAUTION! It is strongly recommended that only original spare parts be used.

SECTION 2 BLADE GUIDE ROLLERS & ARM

2.1 Blade Guide Assembly, Idle Side

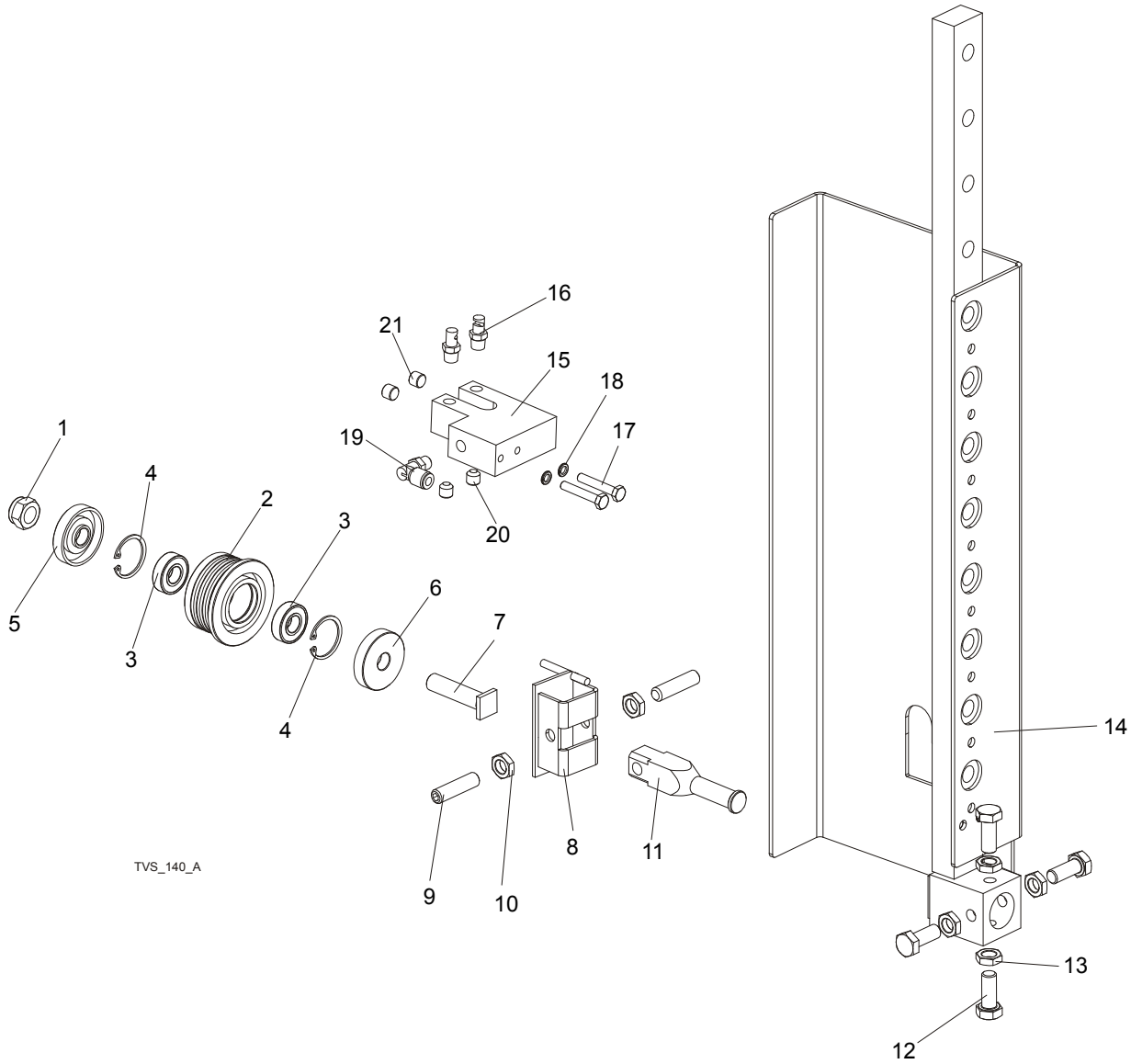

TVS_140_A

REF	DESCRIPTION (◆ Indicates Parts Available In Assemblies Only)	PART #	QTY.	
	ROLLER, TVS BLADE GUIDE COMPLETE	500562	1	
	ROLLER, TVS BLADE GUIDE	500561	1	
1	NUT, M12-8 HEX NYLON ZINC LOCK	F81034-2	1	
2	ROLLER, TVS BLADE GUIDE WIDE	500560	1	◆
3	BEARING, 6001 2RSR FAG	087893	2	
4	RING, W28 INSIDE RETAINING	F81090-9	1	
5	RING, ZINC-PLATED SPACER (FOR EXTEND.ROLL)	087891-1	1	
6	RING, ZINC-PLATED SPACER (FOR EXTEND.ROLL)	087892-1	1	
7	SHAFT, BLADE GUIDE ROLLER ZINC-PLATED	087762-1	1	
8	BRACKET WELDMENT, BLADE GUIDE PAINTED	500563-1	1	
9	SCREW, M10X1X40 DIN 913 A2-70 SET STAINLESS STEEL	F81015-2	2	

Blade Guide Rollers & Arm*Blade Guide Assembly, Idle Side*

10	NUT, M10X1-04-ST-A2 ISO 8675 THIN	F81033-10	2	
11	SHAFT, BLADE GUIDE MOUNT ZINC-PLATED	088255-1	1	
12	BOLT, M10x1x25 DIN 933	F81003-28	4	
13	NUT, M10x1-04-ST-A2 ISO 8675 THIN	F81033-10	4	
14	ROLLER GUIDE, TVS RIGHT-PTD	508387-1	1	
	ROLLER GUIDE, TVS LEFT- PTD	508390-1	1	
	LUBE SYSTEM, TVS	098583	2	
15	BLOCK, NOZZLE MOUNTING ZINC-PLATED	097943-1	1	
16	NOZZLE, BLADE LUBE SPRAY	033479	2	
17	BOLT, M6x35 8.8 HEX HEAD ZINC	F81001-71	2	
18	WASHER, M6 SPLIT LOCK ZINC	F81053-3	2	
19	Fitting, 1/8MPTx1/4Tube,Elbow,Swivel	P09736	1	
20	Fitting, 1/8 NPT Socket Pipe Plug	P30127	2	
21	PLUG, M10x1 DIN 906 BN40 "BOSSARD"	F81015-3	2	

2.2 Blade Guide Assembly, Drive Side

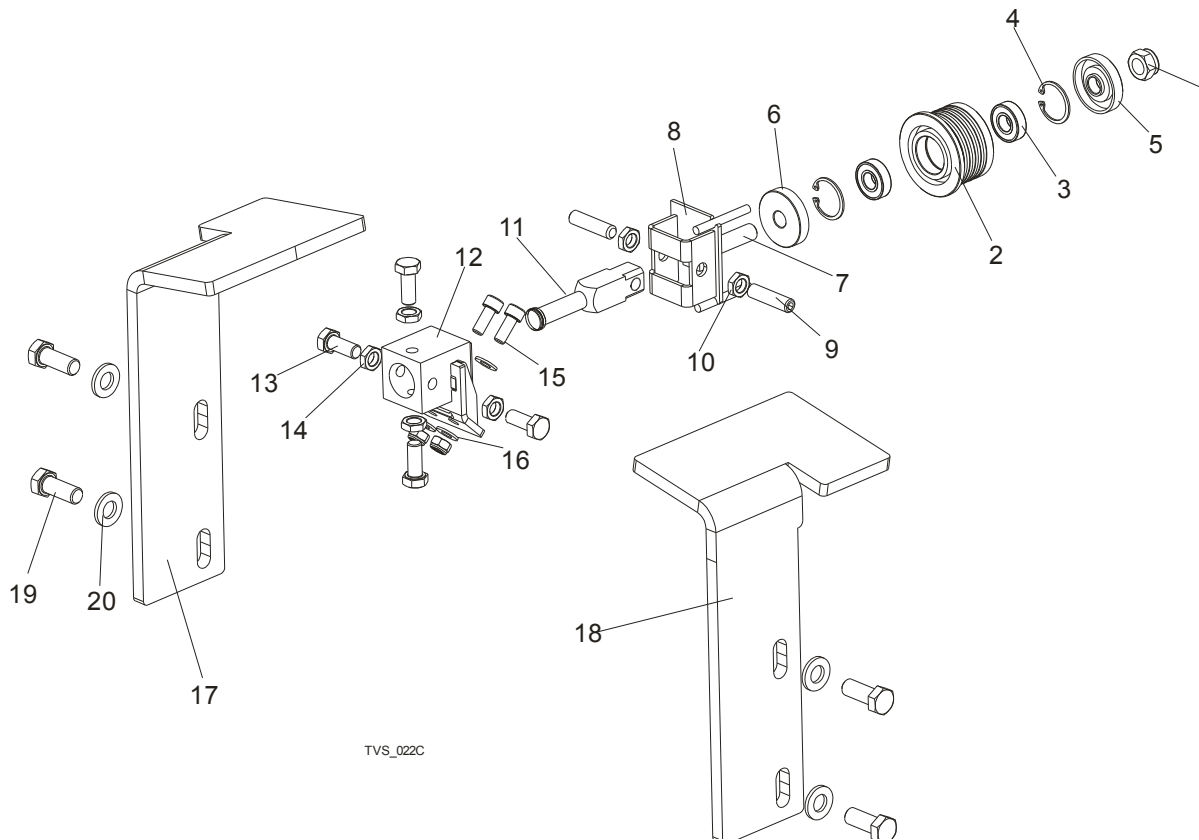

REF	DESCRIPTION (◆ Indicates Parts Available In Assemblies Only)	PART #	QTY.
	ROLLER, TVS BLADE GUIDE COMPLETE	500562	1
	ROLLER, TVS BLADE GUIDE	500561	1
1	NUT, M12-8 HEX NYLON ZINC LOCK	F81034-2	1
2	ROLLER, TVS BLADE GUIDE WIDE	500560	1
3	BEARING, 6001 2RSR FAG	087893	2
4	RING, W28 INSIDE RETAINING	F81090-9	1
5	RING, ZINC-PLATED SPACER (FOR EXTEND.ROLL)	087891-1	1
6	RING, ZINC-PLATED SPACER (FOR EXTEND.ROLL)	087892-1	1
7	SHAFT, BLADE GUIDE ROLLER ZINC-PLATED	087762-1	1
8	BRACKET WELDMENT, BLADE GUIDE PAINTED	500563-1	1
9	SCREW, M10X1X40 DIN 913 A2-70 SET STAINLESS STEEL	F81015-2	2
10	NUT, M10X1-04-ST-A2 ISO 8675 THIN	F81033-10	2
11	SHAFT, BLADE GUIDE MOUNT ZINC-PLATED	088255-1	1
12	BLOCK WELDMENT, PAINTED BLADE GUIDE MOUNT	514887-1	3
13	BOLT, M10X1X25 DIN 933 STAINLESS STEEL	F81003-28	1
14	NUT, M10x1-04-ST-A2 ISO 8675 THIN	F81033-10	4
15	BOLT, M8 X 30-8.8 SOCKET HEAD	F81002-31	2
16	WASHER, 8.2 SPLIT LOCK ZINC	F81054-4	2
17	COVER, DRIVE SIDE ROLLER RIGHT	097660-1	1
18	COVER, DRIVE SIDE ROLLER LEFT	098435-1	1

2**Blade Guide Rollers & Arm***Blade Guide Assembly, Drive Side*

19	BOLT M12x30-8.8 HEX HEAD FULL THREAD ZINC	F81004-22	4	
20	WASHER, M12 FLAT ZINC	F81056-1	4	

SECTION 3 BLADE WHEELS & TENSIONER

3.1 Blade Wheel Assembly, Drive Side

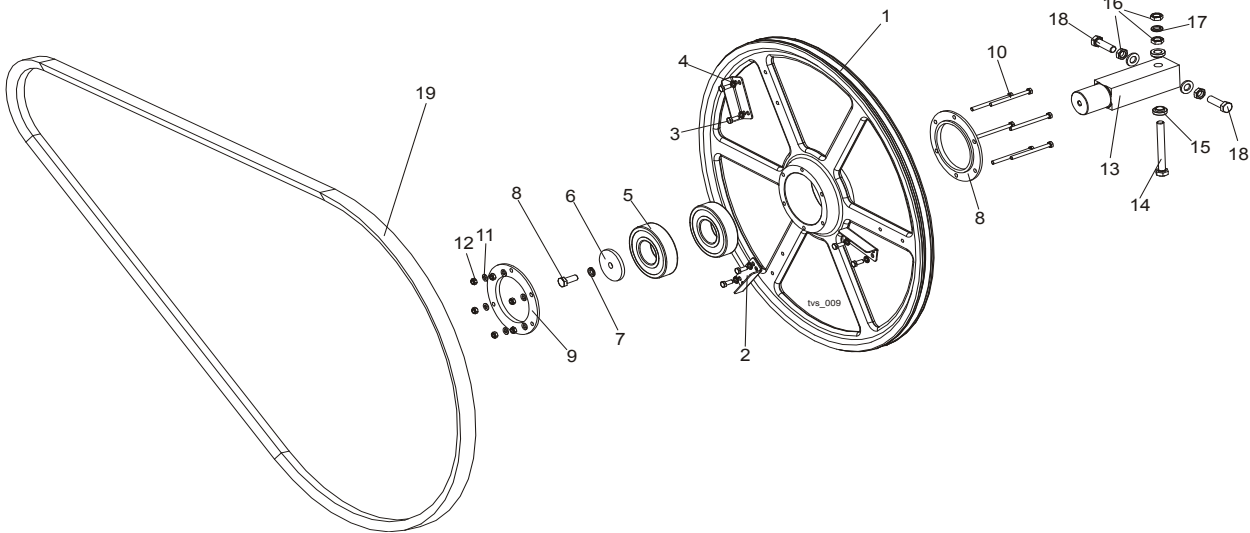

REF	DESCRIPTION (◆ Indicates Parts Available In Assemblies Only)	PART #	QTY.
	DRIVE WHEEL, TVS COMPLETE	096109	1
1	Wheel, Drive-Side Blade Ptd.	096105-1	1
2	Wing, TVS	097808-1	3
3	Bolt, M6 x 16 8.8 Hex Head Full Thread Zinc	F81001-15	6
4	Washer, Z6.1 Split Lock Zinc	F81053-3	6
5	Bearing, 6309 2RSR	096107	2
6	Washer, Idle Blade Wheel Retaining	088957-1	1
7	Washer, 10.2 Split Lock Zinc	F81055-2	1
8	Bolt, M10X25 8.8 Hex Head Full Thread	F81003-31	1
9	Ring, Bearing Mounting	096108-1	2
10	Bolt, M6x80 Hex Head Full Thread Zinc	F81001-61	6
11	Washer, 6.4 Flat Zinc	F81053-1	6
12	Nut, M6-8-B Hex Nylon Zinc Lock	F81031-2	6
13	AXLE, DRIVE WHEEL TVS	096110	1
14	BOLT, M12X1.25X100-8.8 HEX HEAD FULL THREAD ZINC	F81004-41	1
15	SPACER, BLADE GUIDE	086769-1	2
16	NUT, M12X1.25 8.8 HEX ZINC THIN	F81034-5	3
17	WASHER, M12 SPLIT LOCK ZINC	F81056-2	1
18	BOLT, M12X1.25X40 HEX HEAD ZINC	F81004-42	2
19	BELT, 5VX1080	033391	1

3 Blade Wheels & Tensioner

Blade Wheel Assembly, Idle Side

3.2 Blade Wheel Assembly, Idle Side

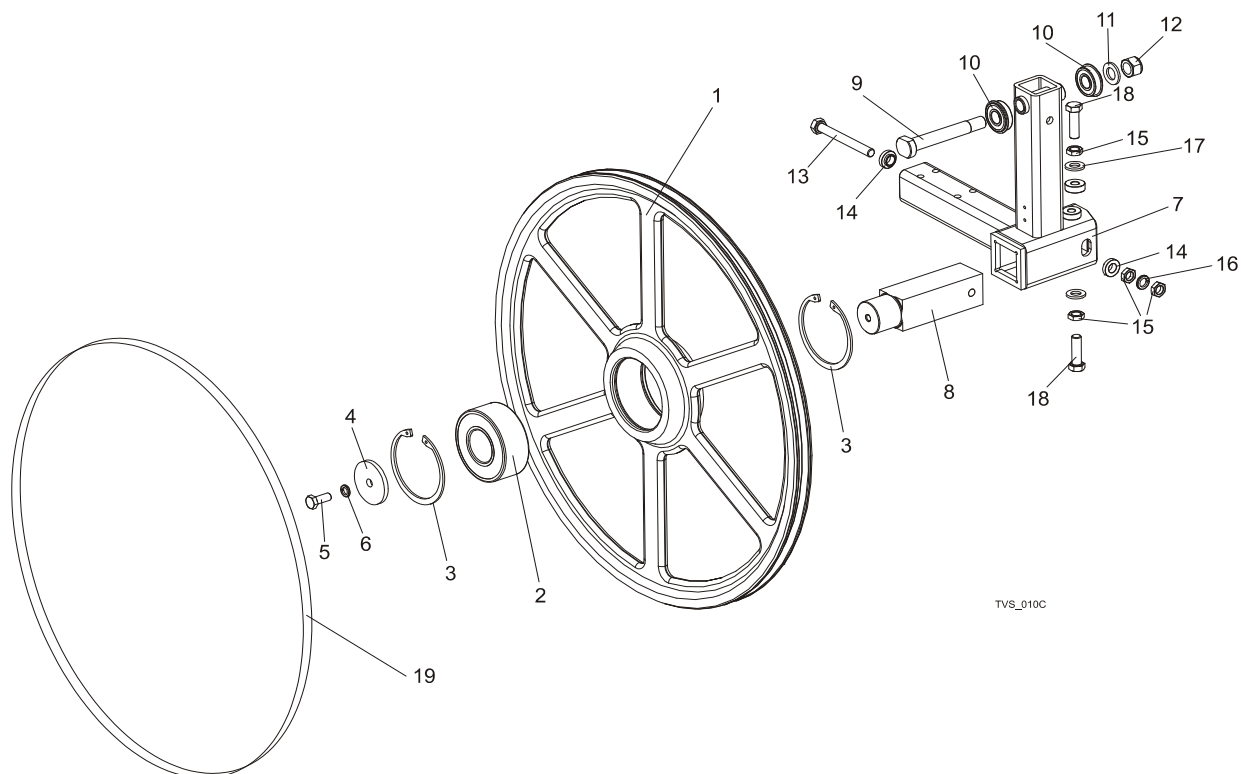

REF	DESCRIPTION (◆ Indicates Parts Available In Assemblies Only)	PART #	QTY.
	WHEEL ASSEMBLY, IDLE SIDE COMPLETE	088764	1
1	Wheel, Idle Side Ptd.	090810-1	1
2	Bearing, 3309B.2RSR.TVH FAG	086428	1
3	Ring, W100 Inside Retaining	F81090-10	2
4	WASHER, BLADE WHEEL RETAINING ZINC-PLATED	088957	1
5	BOLT, M10X25 8.8 HEX HEAD FULL THREAD	F81003-31	1
6	WASHER, 10.2 SPLIT LOCK ZINC	F81055-2	1
7	ARM WELDMENT, TVS IDLE LEFT SIDE BLADE WHEEL	504816-1	1
	ARM WELDMENT, TVS IDLE RIGHT SIDE BLADE WHEEL	504817-1	1
8	SHAFT, IDLE SIDE BLADE WHEEL	088474	1
9	BOLT, ARM BEARING MOUNT	086404	1
10	BEARING, 6203-2RS NR NSK W/SNAP RING	086395	2
11	WASHER, 17 FLAT ZINC	F81058-1	1
12	NUT, M16-8 HEX NYLON ZINC LOCK	F81036-2	1
13	BOLT, M12X1.25X100-8.8 HEX HEAD FULL THREAD ZINC	F81004-41	1
14	WASHER, FLANGED ZINC-PLATED	086769-1	2
15	NUT, M12X1.25 8.8 HEX THIN ZINC	F81034-5	4
16	WASHER, Z12.2 SPLIT LOCK ZINC	F81056-2	1
17	WASHER, 13 FLAT ZINC	F81056-1	2
18	BOLT, M12X1.25X40-8.8 HEX HEAD FULL THREAD ZINC	F81004-42	2
19	BELT, B72.5	017922-1	1

3.3 Blade Tensioner Assembly

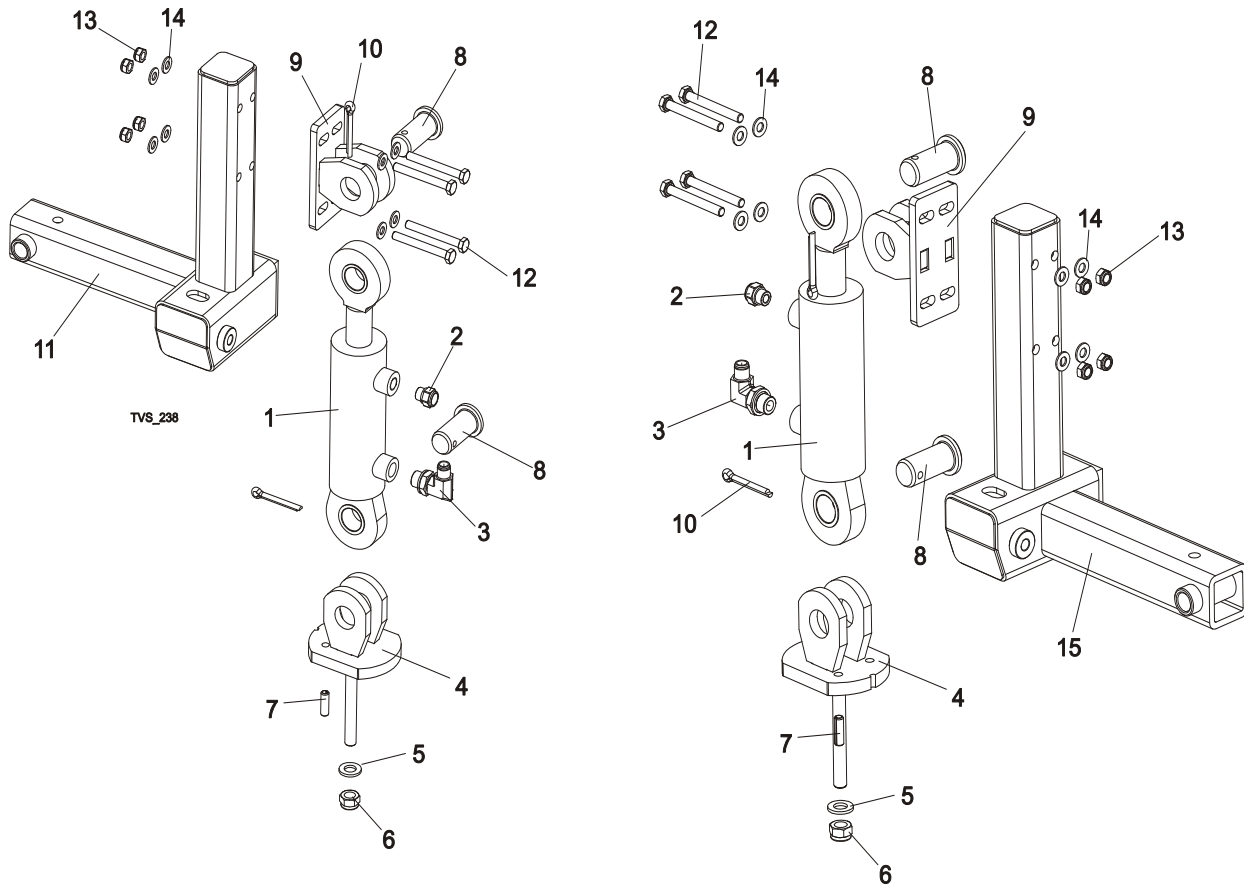

REF	DESCRIPTION (◆ Indicates Parts Available In Assemblies Only)	PART #	QTY.
	HYDRAULIC BLADE TENSIONER, RIGHT SIDE	504826	1
1	CYLINDER, SJ2F-16-50/28/70 HYDRAULIC	504812	1
2	BREATHER, TYPE 2901-14-17	090794	1
3	FITTING, 3/8" BSP-9/16" JIC ELBOW	096335	1
4	BRACKET, HYDRAULIC CYLINDER LOWER MOUNTING	504822-1	1
5	WASHER, M12 FLAT ZINC	F81056-1	1
6	NUT, M12-8 ,HEX NYLON ZINC LOCK	F81034-2	1
7	PIN, 8X26 ROLL ZINC	F81046-4	1
8	PIN, ZINC-PLATED	504824-1	4
9	BRACKET, HYDRAULIC CYLINDER UPPER MOUNTING	504819-1	2
10	PIN, S-ZN 6,3X45 COTTER	F81045-2	4
11	ARM WELDMENT, TVS IDLE RIGHT SIDE BLADE WHEEL	504817-1	1
12	BOLT, M8X70 8.8 HEX HEAD ZINC	F81002-71	8
13	NUT, M8-8-B HEX NYLON ZINC LOCK	F81032-2	8
14	WASHER, 8.4 FLAT ZINC	F81054-1	16
	HYDRAULIC BLADE TENSIONER, LEFT SIDE	504815	1
1	CYLINDER, SJ2F-16-50/28/70 HYDRAULIC	504812	1
2	BREATHER, TYPE 2901-14-17	090794	1
3	FITTING, 3/8" BSP-9/16" JIC ELBOW	096335	1
4	BRACKET, HYDRAULIC CYLINDER LOWER MOUNTING	504822-1	1

3**Blade Wheels & Tensioner***Blade Tensioner Assembly*

5	WASHER, M12 FLAT ZINC	F81056-1	1	
6	NUT, M12-8 HEX NYLON ZINC LOCK	F81034-2	1	
7	PIN, 8X26 ROLL ZINC	F81046-4	1	
8	PIN, ZINC-PLATED	504824-1	4	
9	BRACKET, HYDRAULIC CYLINDER UPPER MOUNTING	504819-1	2	
10	PIN, S-ZN 6,3X45 CONNER	F81045-2	4	
11	USED IN 504826 ASSEMBLY			
12	BOLT, M8X70 8.8 HEX HEAD ZINC	F81002-71	8	
13	NUT, M8-8-B HEX NYLON ZINC LOCK	F81032-2	8	
14	WASHER, 8.4 FLAT ZINC	F81054-1	16	
15	ARM WELDMENT, TVS IDLE LEFT SIDE BLADE WHEEL	504816-1	1	

3.4 Blade Tensioner Pump Assembly

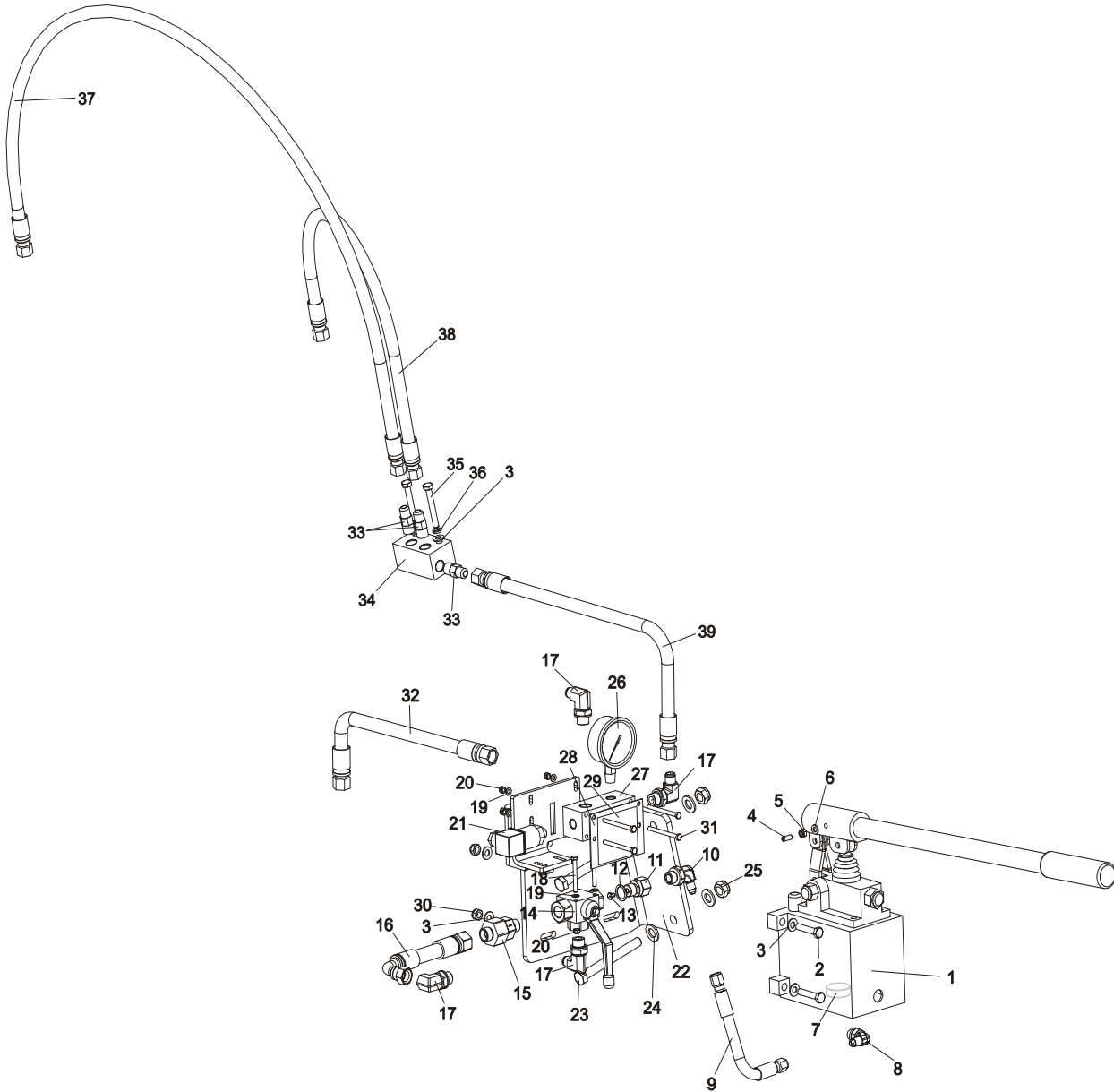

REF	DESCRIPTION (◆ Indicates Parts Available In Assemblies Only)	PART #	QTY.
	BLADE TENSIONER PUMP ASSEMBLY	504825	1
1	PUMP, PMS12/TNK1 W/1-LITRE TANK	092789	1
2	BOLT, M8x40-8.8 HEX HEAD FULL THREAD ZINC	F81002-15	4
3	WASHER, 8.4 FLAT ZINC	F81054-1	10
4	PLUNGER, GN615.3-M6-K BALL THREADED	096874	1
5	NUT, M6-8-B HEX NYLON ZINC LOCK	F81031-2	1
6	WASHER, 6.4 FLAT ZINC	F81053-1	1
7	MAGNET, MW.38x12/N38 NEODYMIUM	500022	1
8	ELBOW, CA-204410-3	094562	1
9	HOSE, 1/4"(0.19M) HYDRAULIC	505174	1

10	ELBOW, CA-204411-3	094563	1	
	FITTING W/NOZZLE, G 3/8	096849	1	
11	FITTING, G3/8 ZINC-PLATED SPECIAL	096850-1	1	
12	WASHER, 16 COPPER	F81058-3	1	
13	NOZZLE, D092-O 1MM DIA. PROPANE&BUTANE	091007	1	
14	VALVE, RSAP3 VOL2L G3/8" THREE-WAY	504803	1	
15	VALVE, RHV12LREDA3C CHECK	094559	1	
16	HOSE, 3/8" W/9/16 ;M18X1.5 END FITTING	504831	1	
17	FITTING, 3/8" BSP-9/16" JIC ELBOW	096335	4	
18	BOLT, M5X45 DIN933 A2-70 STAINLESS STEEL	F81000-22	2	
19	WASHER, 5.3 FLAT ZINC	F81052-1	6	
20	NUT, M5-8 DIN 985 ZINC-PLATED	F81030-2	6	
21	SWITCH, F4-T-I-M3-16 BAR PRESSURE	504830	1	
22	PLATE WELDMENT, PTD MOUNTING	504836-1	1	
23	BOLT, M12x110-8.8-B HEX HEAD ZINC	F81004-47	2	
24	WASHER, 13 FLAT ZINC	F81056-1	4	
25	NUT, M12-8 HEX NYLON ZINC LOCK	F81034-2	2	
26	GAUGE, 3000PSI OIL PRESSURE	505176	1	
27	BLOCK, ZINC-PLATED MOUNTING	504829-1	1	
28	PLATE, ZINC-PLATED	505310-1	1	
29	DECAL, TVS BLADE TENSIONER HANDLE POSITION	505346	1	
30	NUT, M8-8-B HEX NYLON ZINC LOCK	F81032-2	4	
31	BOLT, M5X60 8.8 HEX HEAD ZINC	F81000-36	4	
32	HOSE, 2T3/8X0.380 W9/16UNF-W9/16UNF HYDRAULIC	504706	1	
33	FITTING, G3/8-9/16-18JIC MANUAL PUMP	091842	3	
34	TEE FITTING, ZINC-PLATED	504828-1	1	
35	BOLT, M8X60-8.8 HEX HEAD ZINC	F81002-54	2	
36	WASHER, 8.2 SPLIT LOCK ZINC	F81054-4	2	
37	HOSE, 3/8" 1.2 M HYDRAULIC	504834	1	
38	HOSE, 3/8:"(0.7M) HYDRAULIC	504833	1	
39	HOSE, 2T3/8X0.540 W9/16UNF-W9/16UNF HYDRAULIC	505173	1	

SECTION 4 SAW HEAD

4.1 Middle Throat Screw

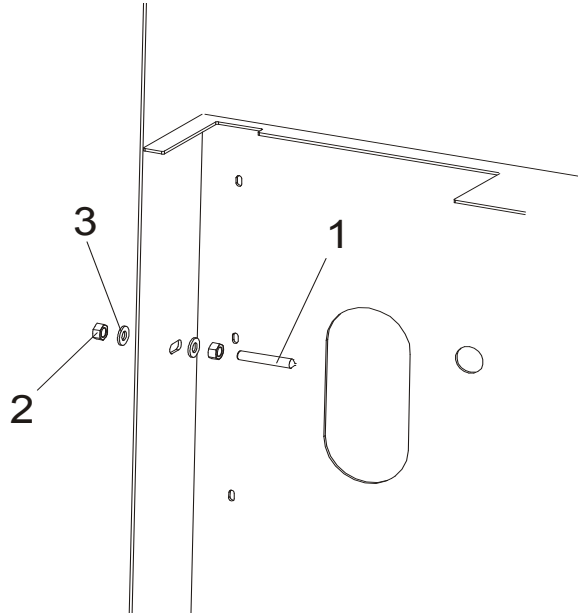

REF.	DESCRIPTION (◆ Indicates Parts Available In Assemblies Only)	PART #	QTY	
1	SCREW, M10X60-45H HEX SOCKET SET CONE POINT ZINC	F81003-87	1	
2	NUT, M10-8-B HEX ZINC	F81033-3	2	
3	WASHER, 10.5 FLAT ZINC	F81055-1	2	

4

Saw Head

Water Lube Assembly (LMS)

4.2 Water Lube Assembly (LMS)

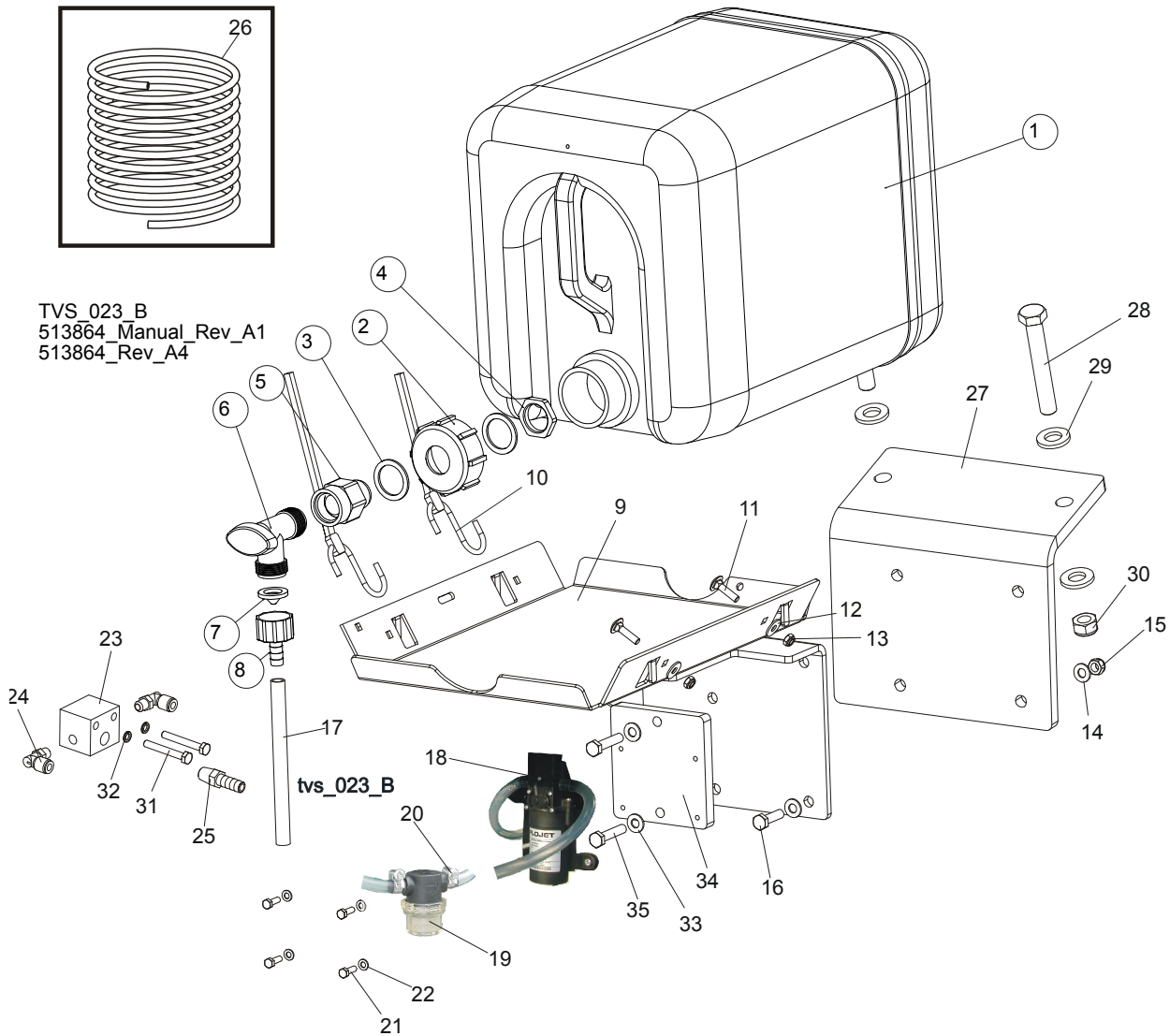

REF.	DESCRIPTION (◆ Indicates Parts Available In Assemblies Only)	PART #	QTY
	BOTTLE KIT, LT20 WATER LUBE	091036	1
	BOTTLE, WATER - COMPLETE	513864	1
	BOTTLE, WATER WITH NUT	513865	1
1	BOTTLE, WATER	513866	1
2	NUT, WATER BOTTLE	513867	1
3	SEAL, 35X26X2 RUBBER	513869	2
4	NUT, 3/4 NPT PACKING	513868	1
5	FITTING, 3/4FPTX3/4MPT	014636	1
6	VALVE, 3/4 NPT ELBOW 3/4 MALE OUTLET PVC	014100	1
7	FILTER, WATER LUBE	016086	1
8	REDUCER, 5/8NPT/3/8BARB WATER LUBE	014113	1
9	TRAY WELDMENT, LT20 WATER LUBE	091033-1	1
10	STRAP, 20 RUBBER W/HOOK	P11668	2
11	BOLT, M6X25-8.8 CARRIAGE HEAD ZINC	F81001-20	2

12	WASHER, 6.5 SPECIAL FLAT ZINC	F81053-11	2	
13	NUT, M6-8-B HEX NYLON ZINC LOCK	F81031-2	2	
14	WASHER, 8.4 FLAT ZINC	F81054-1	8	
15	NUT, M8-8-B HEX NYLON ZINC LOCK	F81032-2	4	
16	BOLT, M8X20-8.8-B HEX HEAD FULL THREAD ZINC	F81002-4	4	
17	TUBING, WATER LUBE	R01885	1	
18	PUMP ASSEMBLY, PRESSURE LUBE	510763	1	
19	FILTER, PRESSURE LUBE	033447	1	
	SCREEN KIT, MESH FILTER	033441	1	
20	CLAMP, PLASTIC HOSE DIA. 8-12MM	F81080-1	2	
21	BOLT, M5X16-5.8-HEX HEAD FULL THREAD ZINC	F81000-51	4	
22	WASHER, 5.3 FLAT ZINC	F81052-1	4	
23	FITTING, TEE TVS LMS	099213-1	1	
24	FITTING, 1/8MPTX1/4TUBE ELBOW SWIVEL	P09736	2	
25	FITTING, 1/4NPT-3/8 BARB	014685	1	
26	HOSE, 1/4" OD X 6 1/2'	033456	1	
27	BRACKET, WATER TANK MOUNTING	502906-1	1	
28	BOLT, M12X80-8.8 HEX HEAD ZINC	F81004-46	2	
29	WASHER, 13 FLAT ZINC	F81056-1	4	
30	NUT, M12-8-B HEX ZINC	F81034-1	2	
31	BOLT, M6X45-8.8 HEX HEAD ZINC	F81001-6	2	
32	WASHER, Z6.1 SPLIT LOCK ZINC	F81053-3	2	
33	WASHER, 8.4 FLAT ZINC	F81054-1	2	
34	RACKET, LMS PUMP ZINC	098762-1	1	
35	BOLT, M8x40-8.8 HEX HEAD FULL THREAD ZINC	F81002-15	2	

4.3 Saw Head Decals

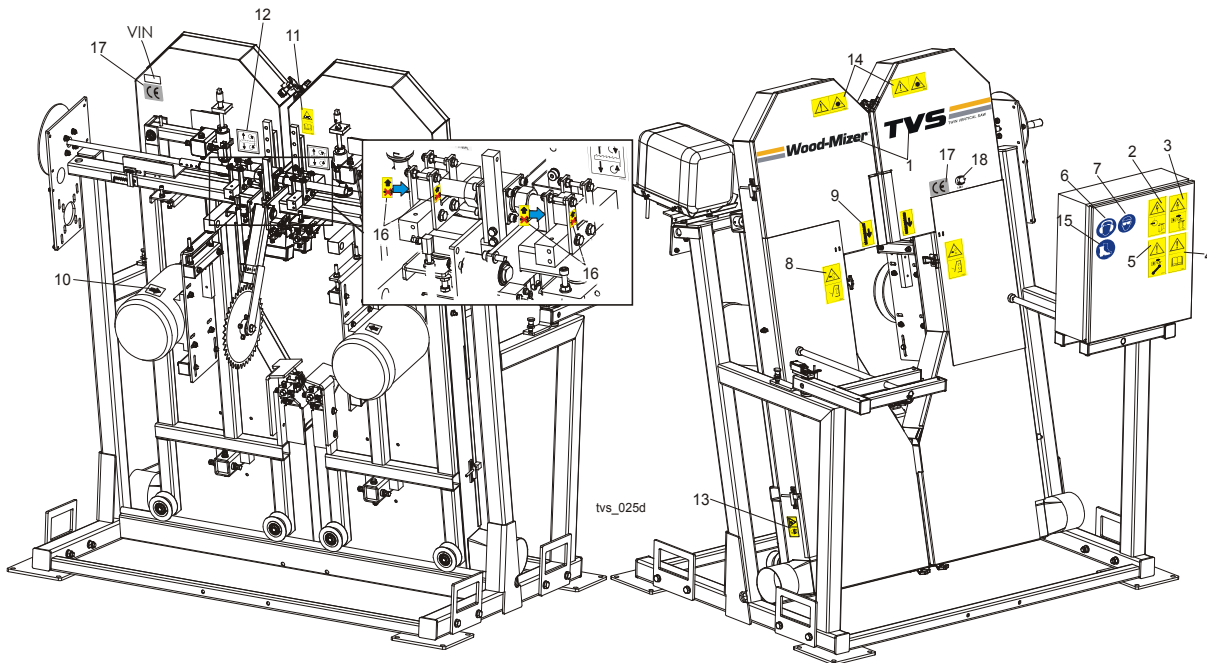

REF.	DESCRIPTION (◆ Indicates Parts Available In Assemblies Only)	PART #	QTY
	DECALS KIT, TVS COMPLETE (PICTOGRAMS)	099479	1
1	DECALS, TVS NAME	099422	1
2	DECAL, HIGH VOLTAGE IN ELECTRIC BOX	096316	1
3	DECAL, DISCONNECT POWER SUPPLY BEFORE OPENING THE BOX	096319	1
4	DECAL, READ THE MANUAL BEFORE OPERATING THE MACHINE	096317	1
5	DECAL, DISCONNECT POWER SUPPLY BEFORE SERVICING	098177	1
6	DECAL, EAR WARNING	S12005G	1
7	DECAL, EYE WARNING	S12004G	1
8	DECAL, CLOSE GUARDS PRIOR TO OPERATING THE MACHINE	099220	2
9	DECAL, BLADE MOVEMENT DIRECTION	096321	2
10	DECAL, MOTOR DIRECTION	S20097	2
11	DECAL, BLADE TENSION - INSTRUCTIONS (PICTOGRAM)	099223	1
12	DECAL, BLADE ALIGNMENT	P11789	2
13	DECAL, SAWDUST PROTECTION (PICTOGRAM)	099222	2
14	DECAL, CAUTION - LASER BEAM (OPTIONAL)	099504	2
15	DECAL, USE SAFETY BOOTS (PICTOGRAM)	501465	1
16	DECAL, DO NOT ADJUST NUTS (PICTOGRAM)	500031	4
	TABLE DECALS - See Section 5.7		
17	DECAL, CE CERTIFIED MACHINE (SMALL)	P85070	1
18	DECAL, GOST CERTIFIED MACHINE	099401	1

4.4 Blade Housing Cover

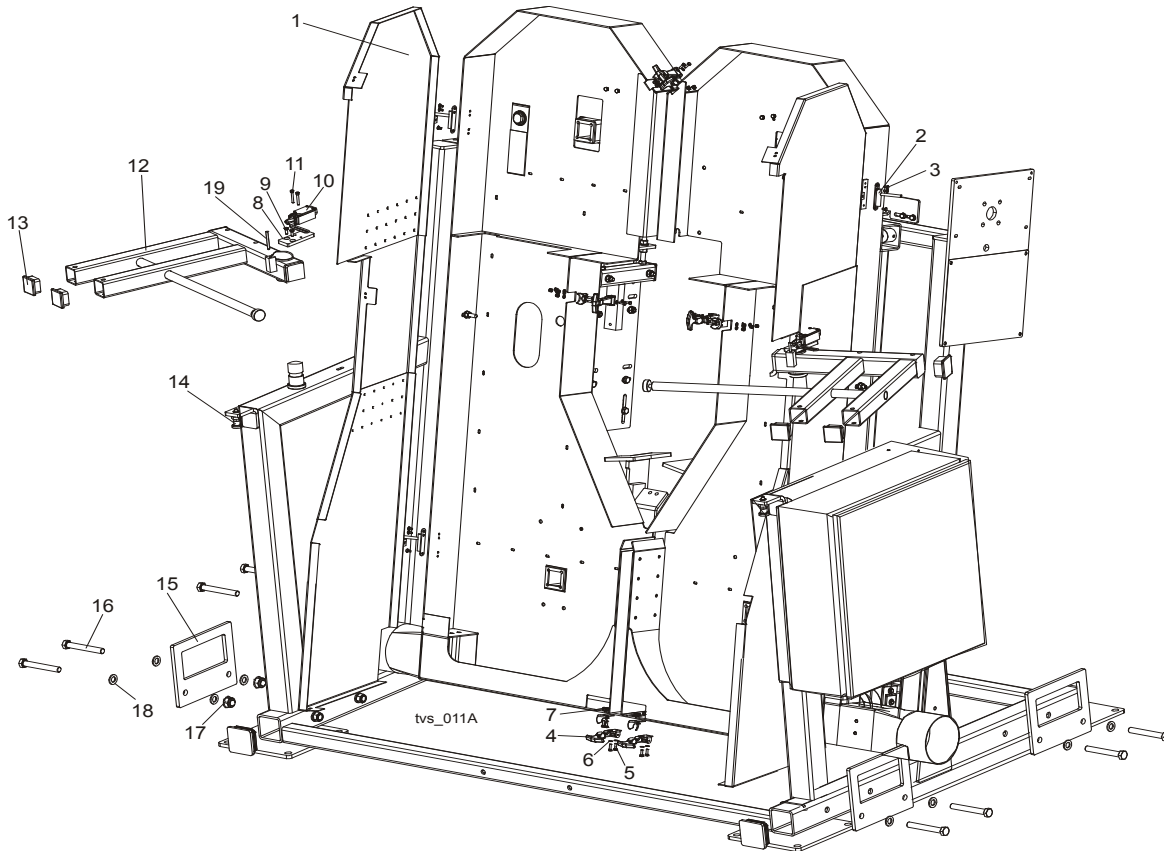

REF.	DESCRIPTION (◆ Indicates Parts Available In Assemblies Only)	PART #	QTY
1	COVER WELDMNT, TVS BLADE HOUSING - LEFT	098612-1	1
	COVER WELDMNT, TVS BLADE HOUSING - RIGHT	096117-1 (RIGHT)	1
2	HINGE, COVER	096146	4
3	SCREW, M5X12- 5.8-B SLOTTED COUNTERSUNK ZINC	F81000-15	8
4	LATCH, FLEXIBLE DRAW	014829	6
5	BOLT, M5X16-5.8-HEX HEAD FULL THREAD ZINC	F81000-51	12
6	WASHER, 5.3 FLAT ZINC	F81052-1	24
7	NUT, M5-8- DIN 985 ZINC	F81030-2	12
8	FLAT BAR, LIMIT SWITCH MOUNTING ZINC	098760-1	2
9	SCREW, M6X16 HEX SOCKET HEAD CAP	F81001-21	4
10	SWITCH, GSCA 01S1 LIMIT	088407	2
11	BOLT, M5X35 8.8 HEX SOCKET HEAD CAP ZINC	F81000-73	4
12	ARM WELDMNT, TVS CONTROL BOX MOUNTING - LEFT	098611-1	2
	ARM WELDMNT, TVS CONTROL BOX MOUNTING - RIGHT	096370-1	2
13	CAP, 50X50 (3-5MM THICK) #199274 SHR TUBE END	095371	4
14	PIN, DETENT	090197	2
15	PLATE, TVS MOUNTING	099145-1	4
16	BOLT, M16X120 -8.8- A2E ISO 24014	F81006-25	8
17	NUT, M16-8 HEX NYLON ZINC LOCK	F81036-2	8
18	WASHER, 17 FLAT ZINC	F81058-1	16

4**Saw Head***Blade Housing Cover*

19	PIN, 5M6X50 DIN 6325 HRC60	F81048-8	2	
----	----------------------------	----------	---	--

4.5 Cutting Width Manual Setting Assembly

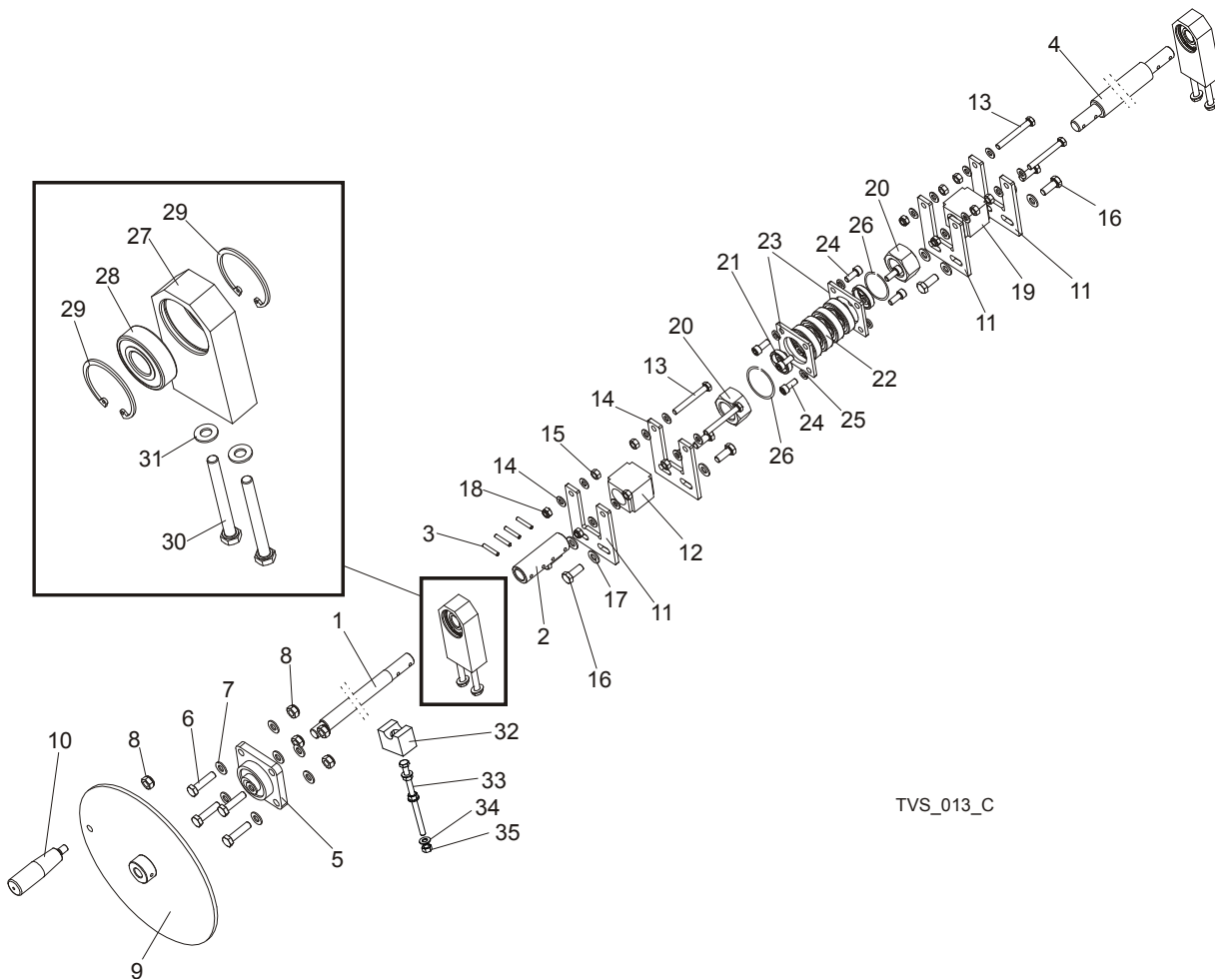

TVS_013_C

REF.	DESCRIPTION (◆ Indicates Parts Available In Assemblies Only)	PART #	QTY
	SCREW, TVS CUTTING WIDTH SETTING - COMPLETE	097664	1
1	ROD, SAW HEAD WIDTH ADJUSTMENT	096359-1	1
2	FASTENER, SAW HEAD WIDTH ADJUSTMENT SCREW	097665-1	1
3	PIN, 5X30 ROLL ZINC	F81044-21	4
4	SCREW, SAW HEAD WIDTH ADJUSTMENT TVS	096154-1	1
5	BEARING, UCF 204 W/HOUSING	097667	1
6	BOLT, M10X40-8.8 HEX HEAD FULL THREAD ZINC	F81003-16	4
7	WASHER, M10 FLAT ZINC	F81055-1	8
8	NUT, M10 NYLON HEX ZINC LOCK	F81033-1	5
9	DISK WELDMENT, CUTTING WIDTH SETTING SCREW	098617-1	1
10	KNOB, PLASTIC CRANK HANDLE	086338	1
11	BRACKET, TURNBUCKLE MOUNT ZINC-PLATED	096861-1	2
12	TURNBUCKLE, M30 TVS	101439	1
13	BOLT, M8X65 8.8 HEX HEAD FULL THREAD ZINC	F81002-9	2
14	WASHER, 8.4 FLAT ZINC	F81054-1	8
15	NUT, M8-8-B HEX ZINC	F81032-1	4
16	BOLT, M10x25-8.8 HEX HEAD FULL THREAD ZINC	F81003-11	4

4

Saw Head*Cutting Width Manual Setting Assembly*

17	WASHER, 10.5 FLAT ZINC	F81055-1	4	
18	NUT, M8-8-B HEX NYLON LOCK ZINC	F81032-2	2	
19	TURNBUCKLE - M30 LH TVS	101440	1	
20	NUT, M30 HEX ZINC	F81038-3	2	
21	BUSHING, FI 34 X 38 X 8 SPACER	096356-1	2	
22	BEARING, 6006 2RSR	096191	4	
23	BRACKET, BEARING MOUNT BLOCK TVS-ZINC	096157-1	2	
24	BOLT, M8X20 -8.8-HEX SOCKET HEAD CAP ZINC	F81002-30	8	
25	WASHER, 8.2 SPLIT LOCK ZINC	F81054-4	8	
26	WASHER, Z30.5 SPLIT LOCK	F81068-1	2	
	BLOCK, TVS CUTTING WIDTH SETTING SCREW - COMPLETE	500012	2	
27	BLOCK, TVS CUTTING WIDTH SETTING SCREW	500011-1	1	
28	BEARING, 6204 2RS-CX ROLLING	088447	1	
29	RING, W47 INSIDE RETAINING	089653	2	
30	BOLT, M8 X 75 8.8 HEX HEAD ZINC	F81002-91	2	
31	WASHER, 8.4 FLAT ZINC	F81054-1	2	
	BOLT ASSEMBLY, HANDLE BRAKING	516336	1	
32	BLOCK, HANDLE BRAKING BOLT ASSEMBLY	517532	1	
33	BOLT M8X130 8.8 HEX HEAD FULL THREAD ZINC	F81002-72	1	
34	WASHER, 8.4 FLAT,ZINC	F81054-1	3	
35	NUT, M8-8-B HEX ZINC	F81032-1	3	

4.6 Cutting Width Automatic Setting Assembly

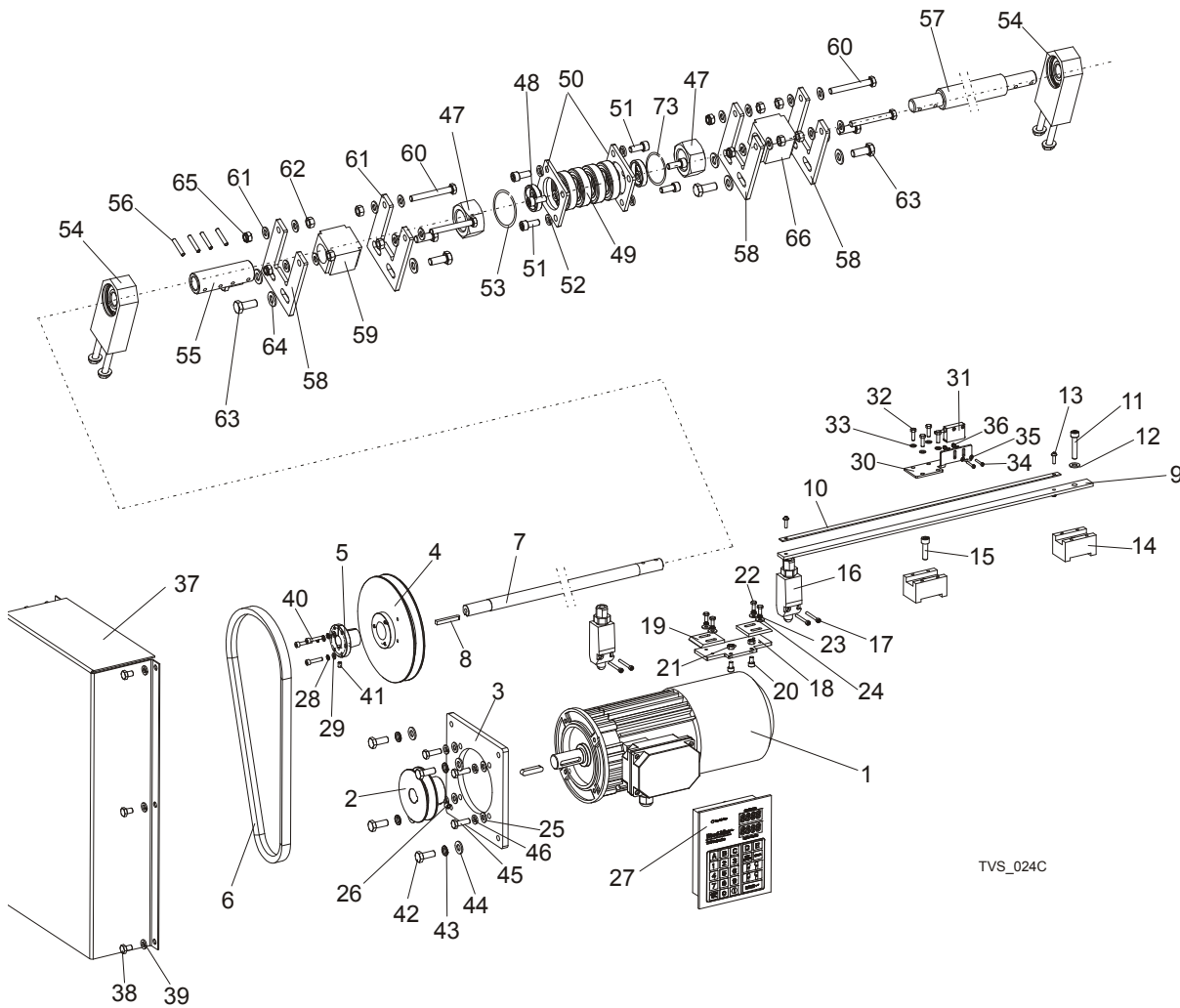

TVS_024C

REF.	DESCRIPTION (◆ Indicates Parts Available In Assemblies Only)	PART #	QTY	
	SCREW, CUTTING WIDTH SETTING - COMPLETE	099185	1	
	SCREW, CUTTING WIDTH SETTING - COMPLETE, TVS USA (UL)	099185-4C	1	
1	MOTOR, SKH90-8L1 HPS 0.55KW 750RPM 400V	098891	1	
1	MOTOR, SKh90-8L1 0.55kw 750RPM 400V (TVS-USA)	099515-UL	1	
2	SHEAVE, SAW HEAD WIDTH ADJUSTMENT, TVS	098116-1	1	
3	BRACKET, MOTOR	099181-1	1	
4	SHEAVE, TYPE B $\Phi 180 \times \Phi 30$	098117-1	1	
5	BUSHING, TAPER	099317	1	
6	BELT, TVS	099320	1	
7	ROD, CUTTING WIDTH SETTING	099180-1	1	
8	KEY, AB 6X6X45 PARALLEL	089229	1	
	GUARD, TVS W/MAGNETIC STRIP	502924	1	
9	GUARD, TVS MAGNETIC STRIP	502694	1	◆
10	STRIP, MB320 (1m) MAGNETIC	096014-1	1	
11	SCREW, M8X40-8.8 HEX SOCKED HEAD CAP ZINC	F81002-29	1	
12	WASHER, 8.4 FLAT ZINC	F81054-1	1	
13	WASHER, 4.3 FLAT ZINC	F81051-2	1	

4

Saw Head

Cutting Width Automatic Setting Assembly

14	MOUNTING BLOCK WITH MAGNETIC STRIP	502923	2	
15	SCREW, M8X30-8.8 HEX SOCKET HEAD CAP ZINC	F81002-31	1	
16	LIMIT SWITCH	089816	2	
17	BOLT, M3X20-5.8-A-PAN HEAD	F81000-8	4	
	LIMIT SWITCH ASSEMBLY	098992	1	
18	PLATE, LIMIT SWITCH MOUNT	098988-1	1	
19	BAR, LIMIT SWITCH FLAT	098989	2	
20	SCREW, M6X10 -8.8- HEX SOCKET HEAD CAP ZINC	F81001-12	2	
21	NUT, M6-8 HEX ZINC	F81031-1	2	
22	BOLT, M5 X 12-5.8-HEX HEAD FULL THREAD ZINC	F81000-5	4	
23	WASHER, 5.1 SPLIT LOCK ZINC	F81052-2	4	
24	WASHER, 5.5 SPECIAL FLAT ZINC	F81052-3	4	
25	WASHER, 8.4 FLAT ZINC	F81054-1	4	
26	SCREW, M8x8 45H GEOMET SET	F81014-1	1	
27	CONTROLLER, TBS01	503467	1	
28	WASHER, 5.1 SPLIT LOCK ZINC	F81052-2	3	
29	WASHER, 5.3 FLAT ZINC	F81052-1	3	
30	BRACKET, SENSOR	502922-1	1	
31	SENSOR ASSY, MSK-320	096014	1	
32	BOLT, M5X16-8.8 HEX HEAD FULL THREAD ZINC	F81000-20	4	
33	WASHER, 5.3 FLAT ZINC	F81052-1	4	
34	SCREW, M3X20-5.8-A-PAN HEAD	F81000-8	2	
35	WASHER, 3.2 FLAT ZINC	F81050-2	4	
36	NUT, M3-6- HEX NYLON ZINC LOCK	F81028-2	2	
37	COVER, TVS CUTTING WIDTH SETTING	098121-1	1	
38	BOLT, M8x12-8.8 HEX HEAD FULL THREAD ZINC	F81002-6	6	
39	WASHER, 8.2 SPLIT LOCK ZINC	F81054-4	6	
40	SCREW, M5X25-8.8 HEX SOCKET HEAD CAP ZINC	F81000-7	1	
41	SCREW, M6X8 PAN HEAD	F81013-1	1	
42	BOLT, M10x25-8.8 HEX HEAD FULL THREAD ZINC	F81003-11	4	
43	WASHER, 10.2 SPLIT LOCK ZINC	F81055-2	4	
44	WASHER, 10.5 FLAT ZINC	F81055-1	4	
45	BOLT, M8x25-8.8-B HEX HEAD FULL THREAD ZINC	F81002-5	4	
46	WASHER, 8.2 SPLIT LOCK ZINC	F81054-4	4	
47	NUT, M30 HEX ZINC	F81038-3	2	
48	BUSHING, FI 34 X 38 X 8 SPACER	096356-1	2	
49	BEARING, 6006 2RSR	096191	4	
50	BRACKET, BEARING MOUNT BLOCK TVS-ZINC	096157-1	2	
51	BOLT, M8X20-8.8 HEX SOCKET HEAD CAP ZINC	F81002-30	8	
52	WASHER, 8.2 SPLIT LOCK ZINC	F81054-4	8	
53	WASHER, Z30.5 SPLIT LOCK ZINC	F81068-1	2	
54	BLOCK, TVS CUTTING WIDTH SETTING SCREW - COMPLETE	500012	2	
55	FASTENER, CUTTING WIDTH SETTING SCREW	097665-1	1	
56	PIN, 5X30 ROLL ZINC	F81044-21	4	
57	SCREW, CUTTING WIDTH SETTING TVS	096154-1	1	
58	BRACKET, TURNBUCKLE MOUNT ZINC-PLATED	096861-1	2	
59	TURNBUCKLE, M30 TVS	101439	1	
60	BOLT, M8X65 8.8 HEX HEAD FULL THREAD ZINC	F81002-9	2	

61	WASHER, 8.4 FLAT ZINC	F81054-1	8	
62	NUT, M8-8-B HEX ZINC	F81032-1	4	
63	BOLT, M10x25-8.8 HEX HEAD FULL THREAD ZINC	F81003-11	4	
64	WASHER, 10.5 FLAT ZINC	F81055-1	4	
65	NUT, M8-8-B HEX NYLON LOCK ZINC	F81032-2	2	
66	TURNBUCKLE - M30 LH TVS	101440	1	

4.7 Saw Head Width Indicator

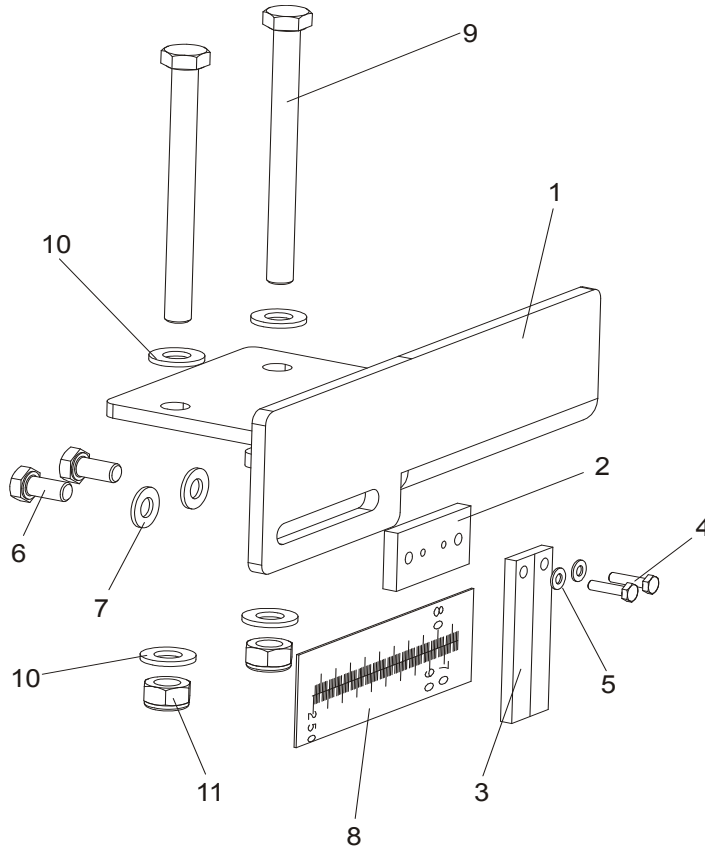

REF.	DESCRIPTION (◆ Indicates Parts Available In Assemblies Only)	PART #	QTY
	SCALE INDICATOR, TVS COMPLETE	098756	1
1	BRACKET, SCALE INDICATOR TVS	098622-1	1
2	BLOCK, BLADE WIDTH INDICATOR REDUCER	094438-1	1
3	INDICATOR, BLADE WIDTH SCALE	094821	1
4	BOLT, M4X16 5.8 HEX HEAD FULL THREAD ZINC	F81011-6	2
5	WASHER, 4.3 FLAT ZINC	F81051-2	2
6	BOLT, M8X16 -8.8-B-HEX HEAD FULL THREAD ZINC	F81002-20	2
7	WASHER, 8.4 FLAT ZINC	F81054-1	2
8	SCALE, TVS METRIC	098619	1
	SCALE, TVS INCH	502669	1
9	BOLT, M10X110 8.8 HEX HEAD ZINC	F81003-43	2
10	WASHER, 10.5 FLAT ZINC	F81055-1	4
11	NUT, M10-8-B NYLON HEX ZINC LOCK	F81033-1	2

4.8 Saw Head Slide Brackets

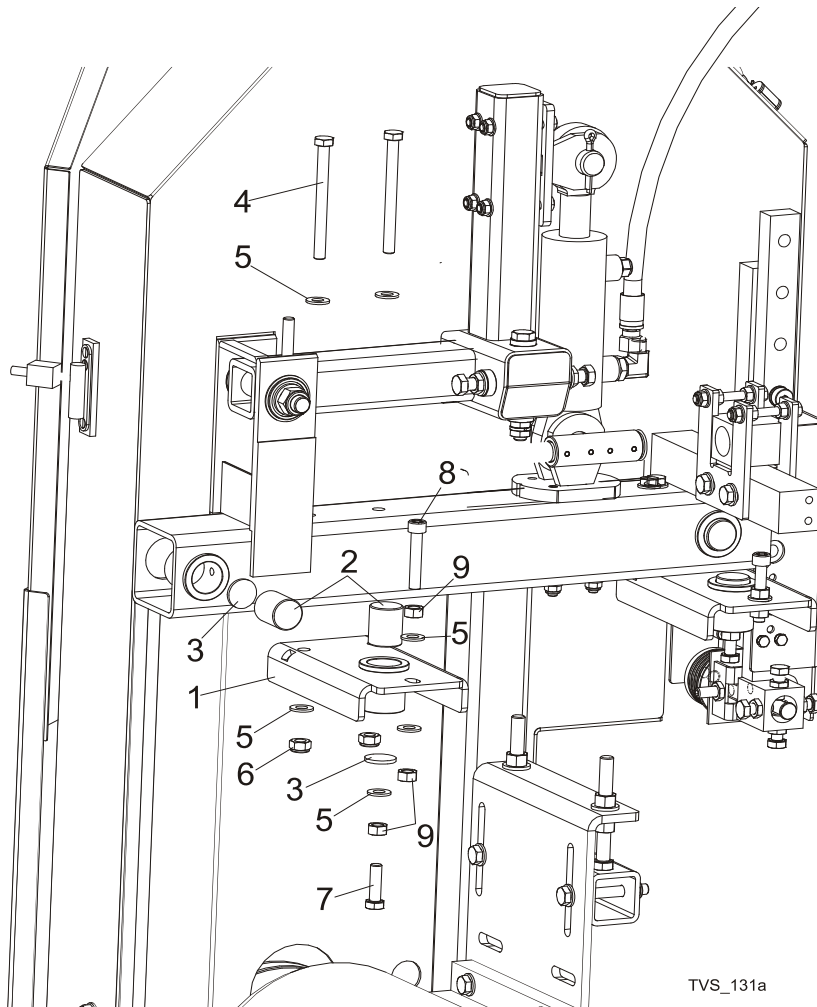

REF.	DESCRIPTION (◆ Indicates Parts Available In Assemblies Only)	PART #	QTY
1	BRACKET, SLIDE LOWER TVS	096838-1	2
2	ROD, SLIDE TVS	096128	4
3	WASHER, BUSHING SLIDE ZINC TVS	096129-1	4
4	BOLT, M10X110 8.8 HEX HEAD ZINC	F81003-43	4
5	WASHER, 10.5 FLAT ZINC	F81055-1	9
6	NUT, M10-8-B NYLON HEX ZINC LOCK	F81033-1	4
7	BOLT, M10X35-8.8 HEX HEAD FULL THREAD ZINC	F81003-17	2
8	SCREW, M10X55-8.8 HEX SOCKET HEAD CAP	F81003-55	2
9	NUT, M10-8-B HEX ZINC	F81033-3	6

4.9 Hold-Down Roller (V-tables)

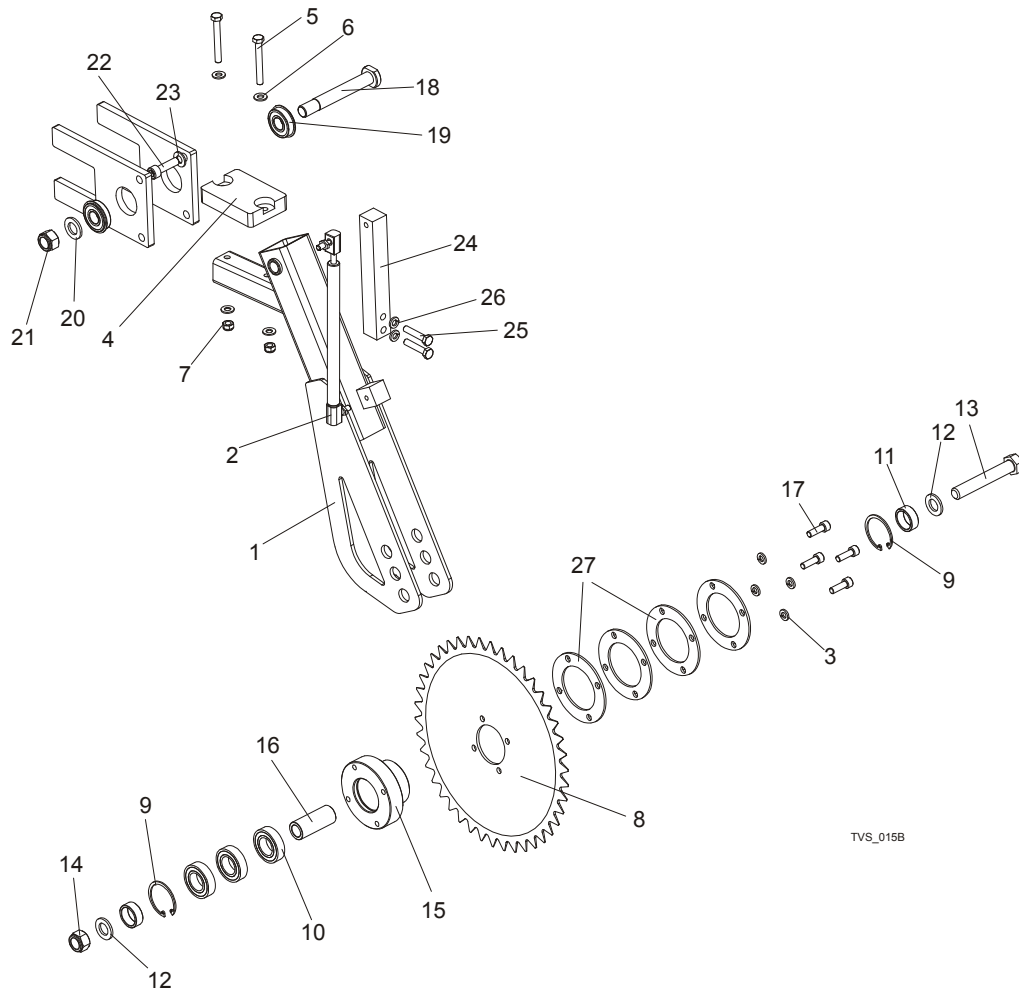

TVS_015B

REF.	DESCRIPTION (◆ Indicates Parts Available in Assemblies Only)	PART #	QTY
	ROLLER, HOLD-DOWN TVS	097954	1
1	ARM, HOLD-DOWN REAR	502765-1	1
2	SPRING, 340N GAS COMPLETE	089212	1
3	WASHER, 8.2 SPLIT LOCK ZINC	F81054-4	4
4	BUMPER, GRENE 70 3201 0010. SHR RUBBER	094969	1
5	BOLT, M8x65-5.8 HEX HEAD ZINC	F81002-3	2
6	WASHER, 8.4 FLAT ZINC	F81054-1	4
7	NUT, M8-8-B HEX NYLON LOCK ZINC	F81032-2	2
8	WHEEL, LOG HOLD-DOWN TVS	096352-1	1
9	RING, W47 INSIDE RETAINING	089653	2
10	BEARING, 6005 2RS CX	089652	3
11	BUSHING, FI 25.5 X 32X12 SPACER ZINC	097942-1	2
12	WASHER, 17 FLAT ZINC	F81058-1	2
13	BOLT, M16x100-8.8 HEX HEAD FULL THREAD ZINC	F81006-2	1
14	NUT, M16-8 HEX NYLON ZINC LOCK	F81036-2	1
15	SHAFT, LOG HOLD-DOWN WHEEL ZINC-PLATED	096351-1	1
16	BUSHING, FI 25X16.5X60 SPACER ZINC	098610-1	1

17	BOLT, M8X25 -8.8- HEX SOCKET HEAD CAP ZINC	F81002-21	4	
18	PIN, IDLER ARM MOUNT	086404	1	
19	BEARING W/SNAP RING 6203-2RS	086395	2	
20	WASHER, 17 FLAT ZINC	F81058-1	1	
21	NUT, M16-8 HEX NYLON ZINC LOCK	F81036-2	1	
22	SCREW, M10X35 HEX SOCKET HEAD CAP ZINC	F81003-56	1	
23	WASHER, 10.5 FLAT ZINC	F81055-1	1	
24	BRACKET, GAS SPRING ZINC	096160-1	1	
25	BOLT, M8x40-8.8 HEX HEAD FULL THREAD ZINC	F81002-15	2	
26	WASHER, 8.2 SPLIT LOCK ZINC	F81054-4	2	
27	SPACER	099530-1	4	

4.10 Saw Head Hold-Down Roller (Spiky Chain Table)

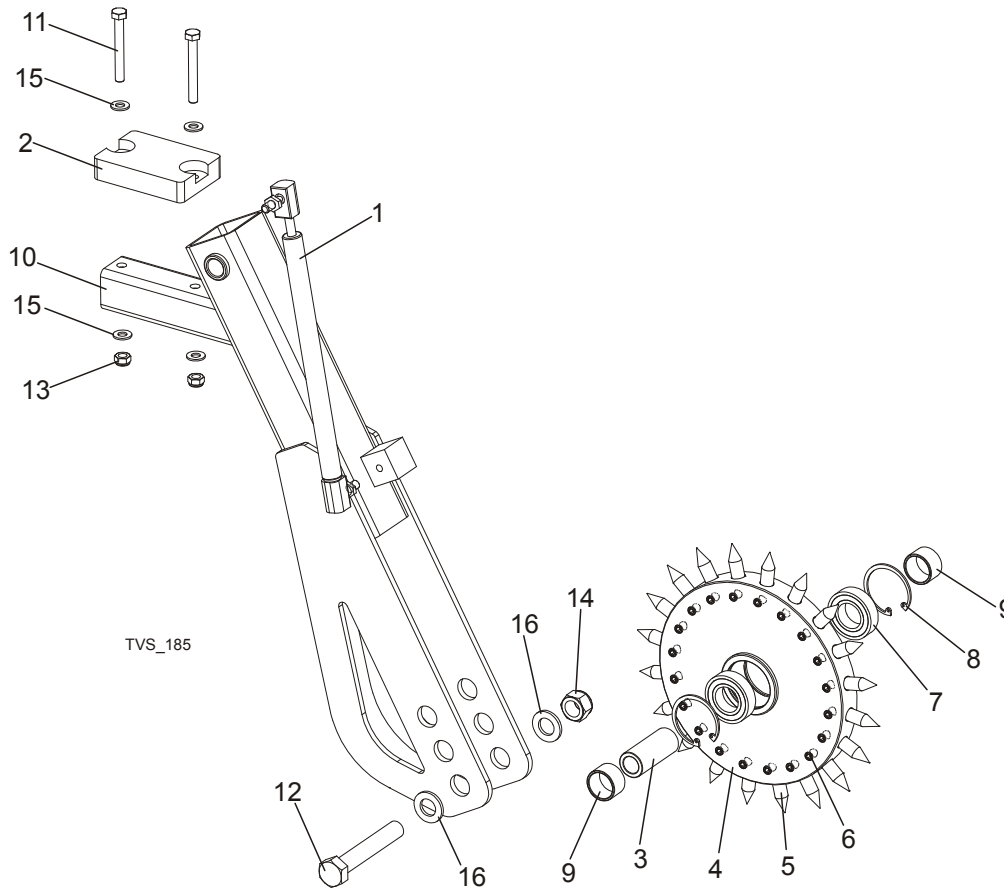

REF.	DESCRIPTION (◆ Indicates Parts Available In Assemblies Only)	PART #	QTY
	ROLLER, TVS-SC SAW HEAD HOLD-DOWN	502766	1
1	SPRING, 340N GAS COMPLETE	089212	1
2	BUMPER, GRENE 70 3201 0010. SHR RUBBER	094969	1
3	BUSHING, FI 25X16,5X60 SPACER ZINC	098610-1	1
	WHEEL, TVS-SC HOLD DOWN COMPLETE	502639	1
4	WHEEL, TVS-SC HOLD DOWN	502638-1	1
5	SPIKE, HOLD- DOWN WHEEL	502651-1	20
6	SCREW, M8x8-33H HEX SOCKET HEAD SET ZINC	F81014-1	20
7	BEARING, 6005 2RS CX	089652	2
8	RING, W47 INSIDE RETAINING	089653	2
9	BUSHING, $\phi 20.5 \times \phi 30 \times 18$ SPACER	502645-1	2
10	ARM, HOLD-DOWN ROLLER REAR	502765-1	1
11	BOLT, M8x65-5.8 HEX HEAD ZINC	F81002-3	2
12	BOLT, M16x100-8.8 HEX HEAD FULL THREAD ZINC	F81006-2	1
13	NUT, M8-8-B HEX NYLON LOCK ZINC	F81032-2	2
14	NUT, M16-8 HEX NYLON ZINC LOCK	F81036-2	1
15	WASHER, 8.4 FLAT ZINC	F81054-1	4
16	WASHER, 17 FLAT ZINC	F81058-1	2

4.11 Hold-Down Roller Assembly (Option)

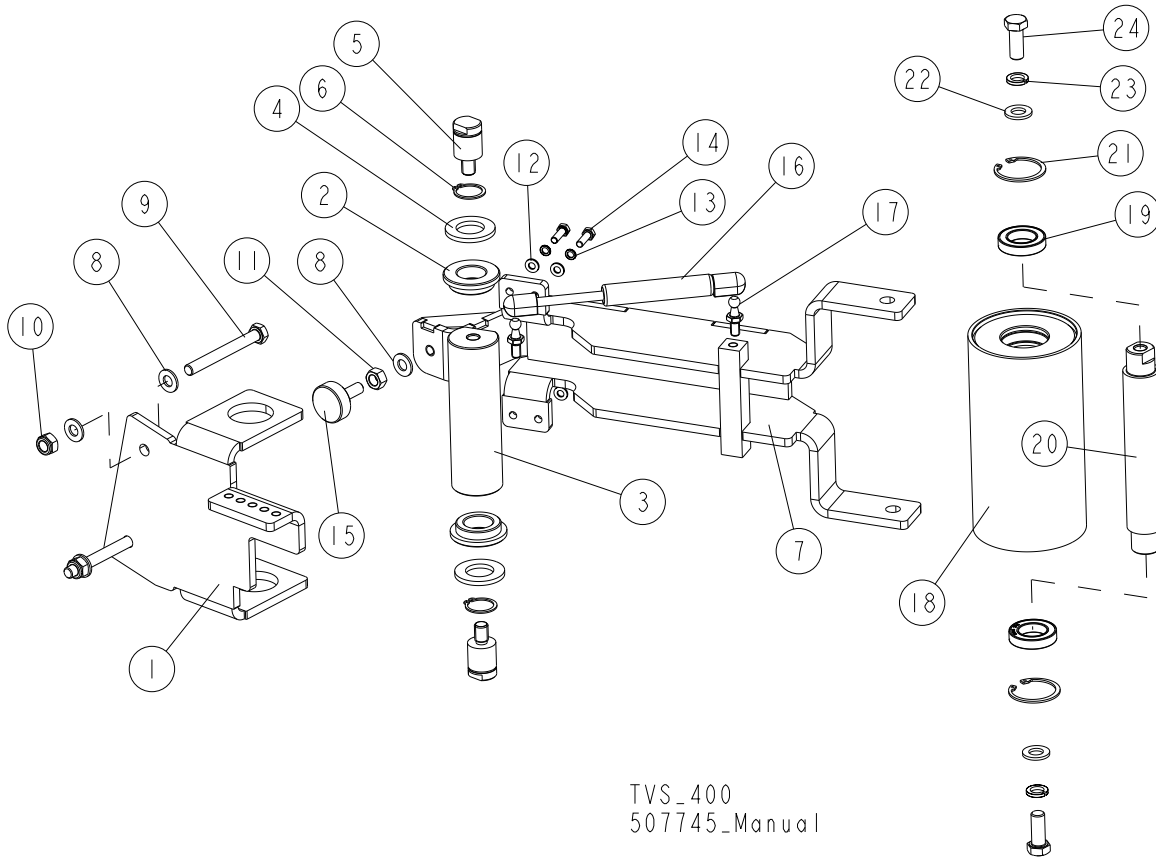

TVS_400
 507745_Manual

REF.	DESCRIPTION (* Indicates Parts Available In Assemblies Only)	PART #	QTY
	ROLLER ASSEMBLY, HOLD-DOWN	507745	1
	ROLLER, HOLD-DOWN LEFT	507730	1
	ROLLER, HOLD-DOWN RIGHT	507740	1
1	BRACKET, MOUNT LEFT	512046-1	1
	BRACKET, MOUNT RIGHT	512045-1	1
2	BUSHING, TVS SC MOUNTING	507738	2
3	PIVOT, GUIDE ROLLER ARM ZINC-PLATED	508182-1	1
4	WASHER, 25 FLAT ZINC	F81061-3	2
5	BOLT, TVS SC ZINC-PLATED MOUNTING	508183-1	2
6	RING, 25Z OUTSIDE RETAINING	F81090-22	2
7	BRACKET, ROLLER HOLD-DOWN COMPLETE	508230-1	1
8	WASHER, 10.5 FLAT ZINC	F81055-1	5
9	BOLT, M10X90-8.8-B HEX HEAD ZINC	F81003-66	2
10	NUT, M10-8-B HEX NYLON ZINC LOCK	F81033-1	2
11	NUT, M10-8-B-FE	F81033-3	1
12	WASHER, 6.4 FLAT ZINC	F81053-1	4
13	WASHER, Z 6.1 SPLIT LOCK ZINC	F81053-3	4
14	BOLT, M6x20-8.8 HEX HEAD FULL THREAD ZINC	F81001-2	4
15	FOOT, BASE ADJUST	092839	1
	GAS, CYLINDER F1=200N COMPLETE	508920	1
16	GAS, CYLINDER F1=200N	508919	1
17	BOLT, M8x17 SPECIAL ZINC	500463	2

4

Saw Head*Hold-Down Roller Assembly (Option)*

REF.	DESCRIPTION (* Indicates Parts Available In Assemblies Only)	PART #	QTY	
	ROLLER, TVS SC COMPLETE	510655	1	
18	GUIDE ROLLER WELDMENT	510653-1	1	
19	BEARING, 61905 2RS CX	099037	2	
20	PIVOT, TVS SC GUIDE ROLLER	510656-1	1	
21	RING, W042 INSIDE RETAINING	F81090-19	2	
22	WASHER, 13 FLAT ZINC	F81056-1	2	
23	WASHER, Z12.2 SPLIT LOCK ZINC	F81056-2	2	
24	BOLT, M12X30-8.8 HEX HEAD FULL THREAD ZINC	F81004-22	2	

4.12 Blade Drive Motor

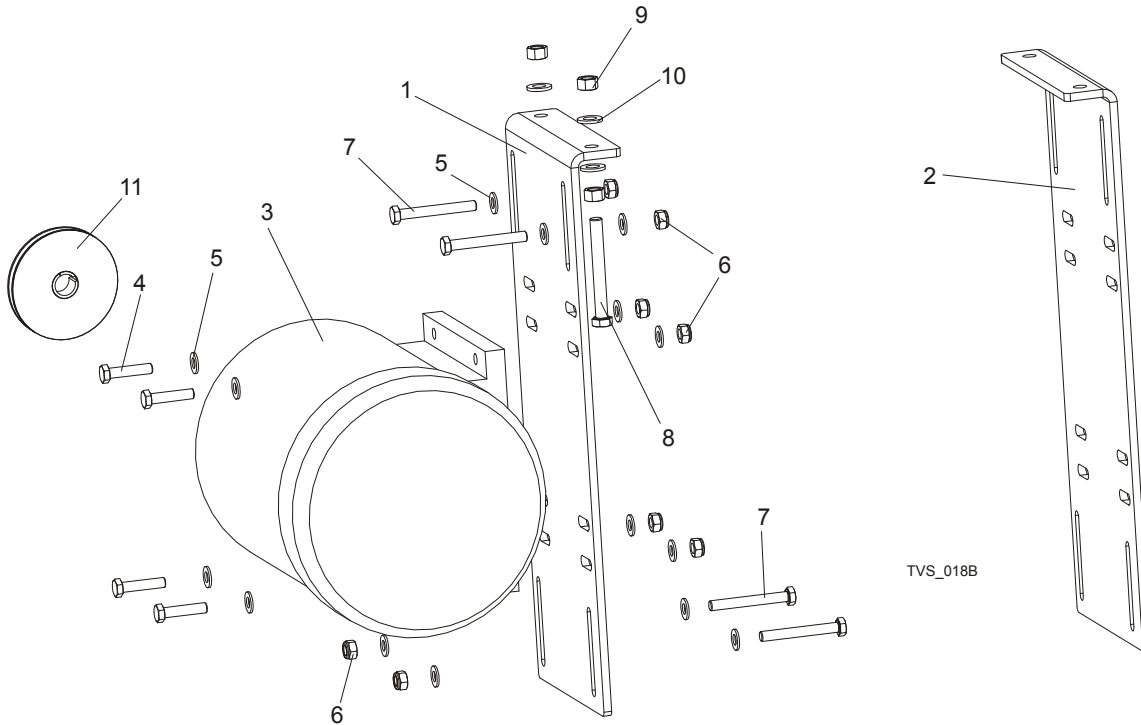

REF.	DESCRIPTION (◆ Indicates Parts Available In Assemblies Only)	PART #	QTY
1	PLATE, MOTOR MOUNT RIGHT - PTD	096123-1	1
	PLATE, MOTOR MOUNT RIGHT - PTD (TVS-USA)	099398-1	1
2	PLATE, MOTOR MOUNT LEFT - PTD	098436-1	1
	PLATE, MOTOR MOUNT LEFT - PTD (TVS-USA)	099397-1	1
3	MOTOR, 7,5KW SG132S-2B HM	090993	2
	MOTOR, 11KW PSg-132 S2 - HM	089049	2
	MOTOR, 12kW 1LE1002-1CA63-4AA4-Z (USA)	P85186-UL	2
	MOTOR, 15KW(20HP)380-420V ELECTRIC (TVS-USA)	086856-UL	2
4	BOLT, M10x45-8.8 HEX HEAD FULL THREAD ZINC	F81003-3	8
5	WASHER, 10.5 FLAT ZINC	F81055-1	32
6	NUT, M10-8-B NYLON HEX ZINC LOCK	F81033-1	16
7	BOLT, M10X80-8.8 HEX ZINC	F81003-50	8
8	BOLT, M12X100 8.8 HEX HEAD FULL THREAD ZINC	F81004-45	4
9	NUT, M12-8-B HEX ZINC	F81034-1	4
10	WASHER, 13 FLAT ZINC	F81056-1	8
	PULLEY, SPB Φ 140X1/ Φ 38 (F02325+T31079)	500571 ¹	2
	PULLEY, SPB Φ 170X1/ Φ 38 (F01794+T31079)	500575 ²	2
	PULLEY, SPB190/1 W/2012/38 TAPER SPLIT BUSHING	099601 ³	2
	PULLEY, SPB125X1/FI38 F02319+T31079 TAPER SPLIT BUSHING	501556 ⁴	2
	PULLEY, ϕ 150/ FI42 F02329+T31081 (TVS-USA)	099503	1

¹ Standard Equipment. Blade Linear Velocity $v=20.5$ m/s.

² Blade Linear Velocity $v=25$ m/s.

³ Blade Linear Velocity $v=28$ m/s.

⁴ Blade Linear Velocity $v=23$ m/s.

4.13 Saw Head Support Rollers

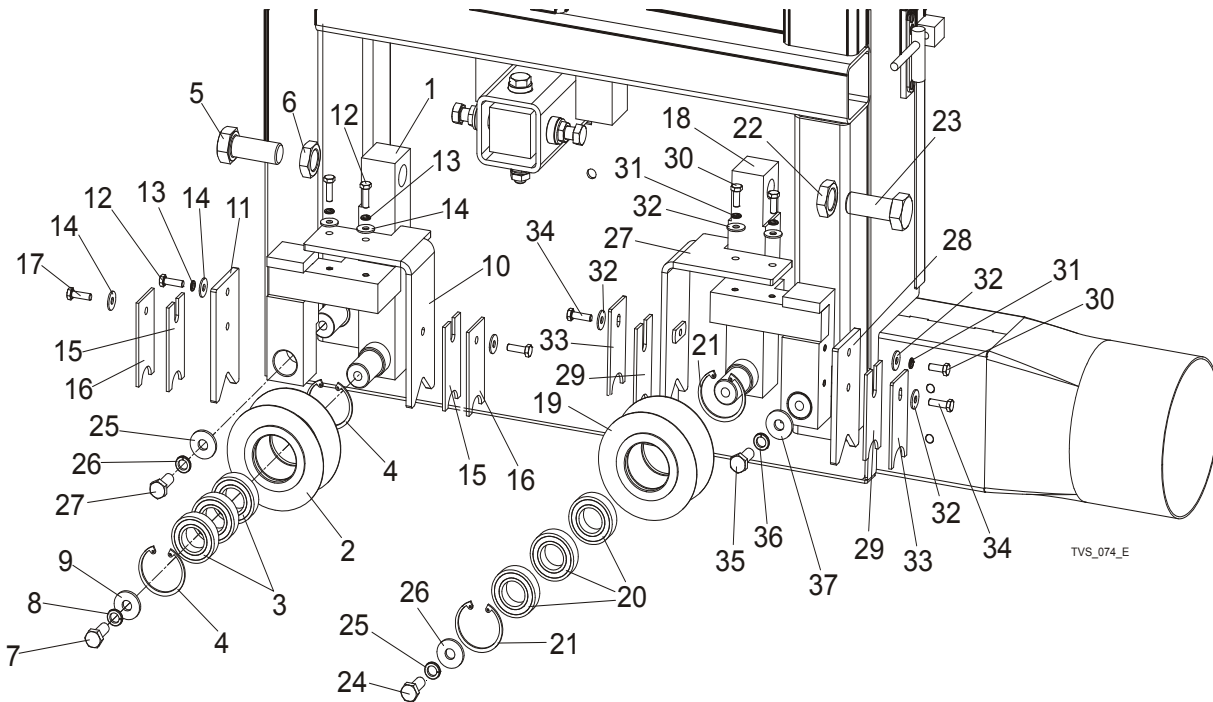

REF.	DESCRIPTION (◆ Indicates Parts Available In Assemblies Only)	PART #	QTY
	ROLLER, TVS SAW HEAD ADJUST SUPPORT, COMPLETE	100179	2
1	SUPPORT, TVS SAW HEAD ROLLER	100177-1	1
	ROLLER, TVS SAW HEAD SUPPORT, COMPLETE	096835	1
2	ROLLER, TVS SAW HEAD SUPPORT, PTD	096834-1	1
3	BEARING, 6005 2RS CX	089652	3
4	RING, W47 SPRING RETAINING	089653	2
5	BOLT, M10X1.5X50-8.8-B ZINC-PLATED	F81007-2	1
6	NUT, M20X1.5 ZINC-PLATED THIN	F81037-7	1
7	BOLT, M10X25-8.8-HEX HEAD FULL THREAD ZINC	F81003-11	1
8	WASHER, 10.2 SPLIT LOCK ZINC	F81055-2	1
9	WASHER, 10.5 ZINC FLAT SPECIAL	F81055-6	1
10	SUPPORT, WIPER RIGHT	101092-1	1
11	SUPPORT, WIPER LEFT	101093-1	1
12	BOLT, M6 X 16 8.8 HEX HEAD FULL THREAD ZINC	F81001-15	3
13	WASHER, Z6.1 SPLIT LOCK ZINC	F81053-3	3
14	WASHER, 6.5 FLAT ZINC	F81053-11	5
15	WIPER, TOP RAIL	101090	2
16	PLATE, TRACK WIPER PTD	088559-1	2
17	BOLT, M6X20-8.8 HEX HEAD FULL THREAD ZINC	F81001-2	2
	ROLLER, TVS SAW HEAD ADJUST SUPPORT LEFT, COMPLETE	509887	2
18	BRACKET, ROLLER WLDMT/PTD	509888-1	1
	ROLLER, TVS SAW HEAD SUPPORT, COMPLETE	096835	1
19	ROLLER, TVS SAW HEAD SUPPORT PTD	096834-1	1
20	BEARING, 6005 2RS CX	089652	3

21	Ring, W47 Spring Retaining	089653	2	
22	NUT, M20X1.5 ZINC-PLATED THIN	F81037-7	1	
23	BOLT, M10X1.5X50-8.8-B ZINC-PLATED	F81007-2	1	
24	BOLT, M10X25-8.8-HEX HEAD FULL THREAD ZINC	F81003-11	1	
25	WASHER, 10.2 SPLIT LOCK ZINC	F81055-2	1	
26	WASHER,10.5 ZINC FLAT SPECIAL	F81055-6	1	
27	SUPPORT, WIPER LEFT	509889-1	1	
28	SUPPORT, WIPER LEFT	101093-1	1	
29	WIPER, TOP RAIL	101090	2	
30	BOLT, M6 X 16 8.8 HEX HEAD FULL THREAD ZINC	F81001-15	3	
31	WASHER, Z6.1 SPLIT LOCK ZINC	F81053-3	3	
32	WASHER, 6.5 FLAT ZINC	F81053-11	5	
33	PLATE, TRACK WIPER PTD	088559-1	2	
34	BOLT, M6X20-8.8 HEX HEAD FULL THREAD ZINC	F81001-2	2	
35	BOLT, M10 X 25 8.8 HEX HEAD FULL THREAD ZINC	F81003-31	2	
36	WASHER, 10.2 SPLIT LOCK ZINC	F81055-2	2	
37	WASHER,10.5 ZINC FLAT SPECIAL	F81055-6	2	

4.14 Electric Box



REF.	DESCRIPTION (◆ Indicates Parts Available In Assemblies Only)	PART #	QTY
	ELECTRIC BOX TVS 400V CE	509150	1
	ELECTRIC BOX TVS 230V CE	509150-2	1
	ELECTRIC BOX TVS 400V	509150-3	1
	ELECTRIC BOX TVS 460V	509150-4	1
	ELECTRIC BOX TVS 230V	509150-5	1
1	SWITCH, ABB OT45E3	095473	1
	HANDWHEEL, OHB2AJ ABB	088265-1	1
	AXIS, OXS5X160 ABB	088265-2	1
2	LIGHT, WHITE CONTROL	090488	1

4.15 Control Box

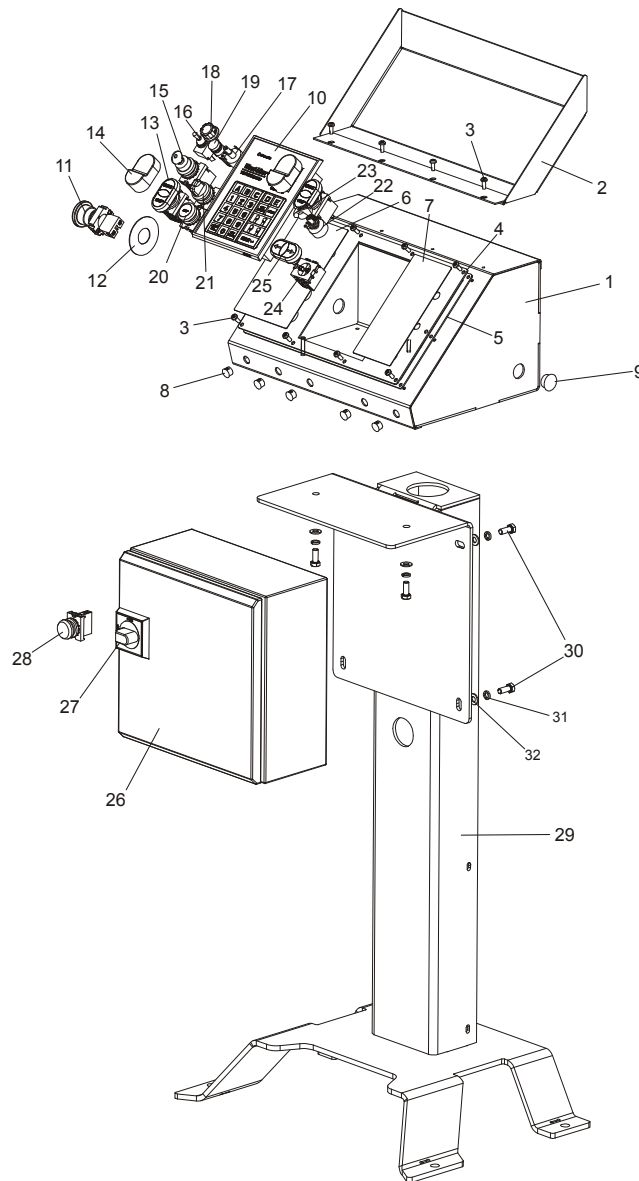

REF.	DESCRIPTION (◆ Indicates Parts Available In Assemblies Only)	PART #	QTY
	CONTROL BOX, TVS COMPLETE	509141	1
1	CONTROL BOX, TVS	510061-1	1
2	COVER, CONTROL BOX - COMPLETE	097135-1	1
3	BOLT, #10-24 X 1/2 PH PAN HD, TYPE 23	F05015-17	12
4	PANEL, TVS FRONT CONTROL	503535-1	1
5	GASKET, LT20 CONTROL BOX	097132	1
6	DECAL, TVS CONTROL BOX LEFT	503538A	1
7	DECAL, TVS CONTROL BOX RIGHT	503538B	1
8	CAP, DP 812 HEJMAN 12.7 DIA. HOLE	086773	5
9	CAP, 22.2 HOLE SR1086	093544	1
10	CONTROLLER, TBS01	503467 ¹	1

	CAP, TVS CONTROL BOX	504378	1	
	DECAL, TVS CONTROL BOX	504379	1	
	DIAPHRAGM, TVS CONTROLLER	083731	1	
11	SWITCH, XB2 BS542 EMERGENCY STOP	086556	1	
12	LEGEND PLATE	086561	1	
	SWITCH, 24V START/STOP	090452	2	
13	LIGHT, M22 WHITE-LED 24V CONTROL	090448	1	
14	MEMBRANE, M22-T-DD	090462	1	
15	SWITCH, M22 3-POSITION KEY	091361	1	
16	SWITCH, DPDT ON/OFF/ON 15A TOGGLE	024588	1	
17	POT, 500K 2W 10% CP PANEL MOUNT	024553	1	
18	KNOB, 1/4 ID FLUTED ROUND PLASTIC	033478	1	
19	CONTROL BULB XB6 AV 3BB	087348	1	
20	SWITCH, M22 STOP	090926	1	
21	SWITCH, M22 3-POSITION ILLUMINATED	091359	1	
22	POTENTIOMETER, 1K LTAGA	E20519	1	
23	KNOB, SPEED CONTROL	P06257	1	
24	ELEMENT, M22-K10 CONTACT	091362	1	
25	BUTTON, M22-DD-S-X7/X7	090917	1	
	BOX, POWER SUPPLY TVS	507258	1	
26	BOX, SAREL S83002 /300x300x150/	092627	1	
27	HANDLE, OHB S2A1 ABB SWITCH	502312-1	1	
28	LIGHT, 1SFA619402L5415 WHITE CONTROL	509129	1	
29	BOX WELDMENT, CONTROL	505555-1	1	
30	BOLT, M8x20-8.8-B HEX HEAD FULL THREAD ZINC	F81002-4	4	
31	WASHER 8.2 SPLIT LOCK ZINC	F81054-4	4	
32	WASHER, 8.4 FLAT ZINC	F81054-1	4	

¹ In machines with Automatic Cutting Width Setting Option only.

4.16 Laser Assembly (Optional)

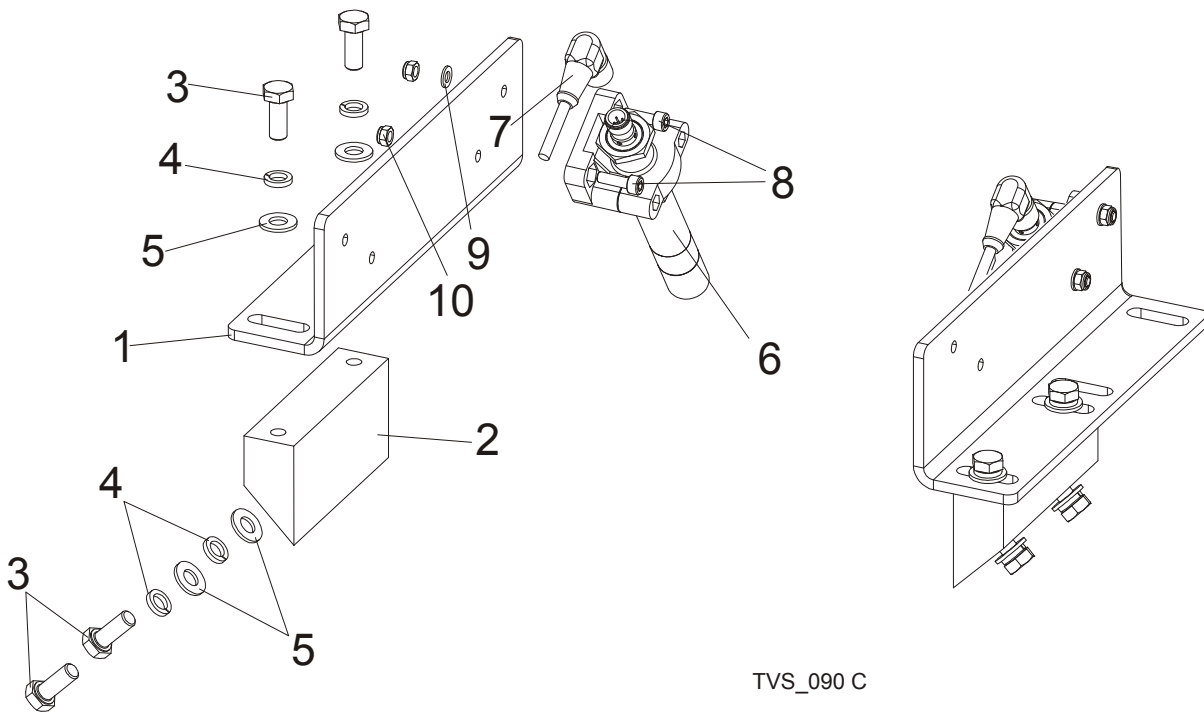

REF.	DESCRIPTION (◆ Indicates Parts Available In Assemblies Only)	PART #	QTY
	TVS LASER ASSEMBLY	100079	1
1	PLATE, TVS LASER MOUNTING	098304	2
2	BRACKET, TVS LASER	098303	2
3	BOLT, M8x20-5.8 HEX HEAD FULL THREAD ZINC	F81002-1	8
4	WASHER, 8.2 SPLIT LOCK ZINC	F81054-4	8
5	WASHER, 8.4 FLAT ZINC	F81054-1	8
6	LASER, Z5M18B-F-532-IG90 GREEN - LINEAR	501025	2
7	CABLE, 5M 4-WIRE SENSOR	087652	2
8	SCREW, M5X16-8.8 HEX SOCKET HEAD CAP ZINC	F81000-25	4
9	WASHER, 5.3 FLAT ZINC	F81052-1	4
10	NUT, M5-8- DIN985 ZINC	F81030-2	4

4

Saw Head

Handle Braking Bolt Assembly (Manual Cutting Width Setting)

4.17 Friction Assembly (Manual Cutting Width Setting)

TVS_408
516366_Oper_Manual

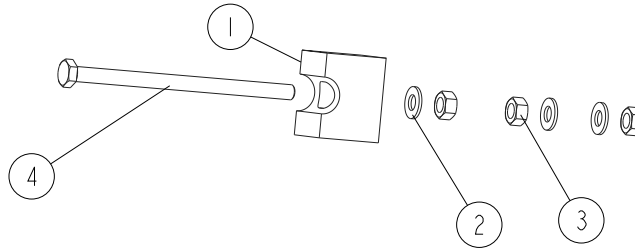

REF.	DESCRIPTION (◆ Indicates Parts Available In Assemblies Only)	PART #	QTY
	FRICTION ASSEMBLY	516336	1
1	BLOCK, FRICTION ASSEMBLY	517532	1
2	WASHER, 8.4 FLAT ZINC	F81054-1	3
3	NUT, M8-8-B HEX ZINC	F81032-1	3
4	BOLT, M8X130 8.8 HEX HEAD FULL THREAD ZINC	F81002-72	1

SECTION 5 INFEED & OUTFEED TABLES

5.1 TVS Infeed

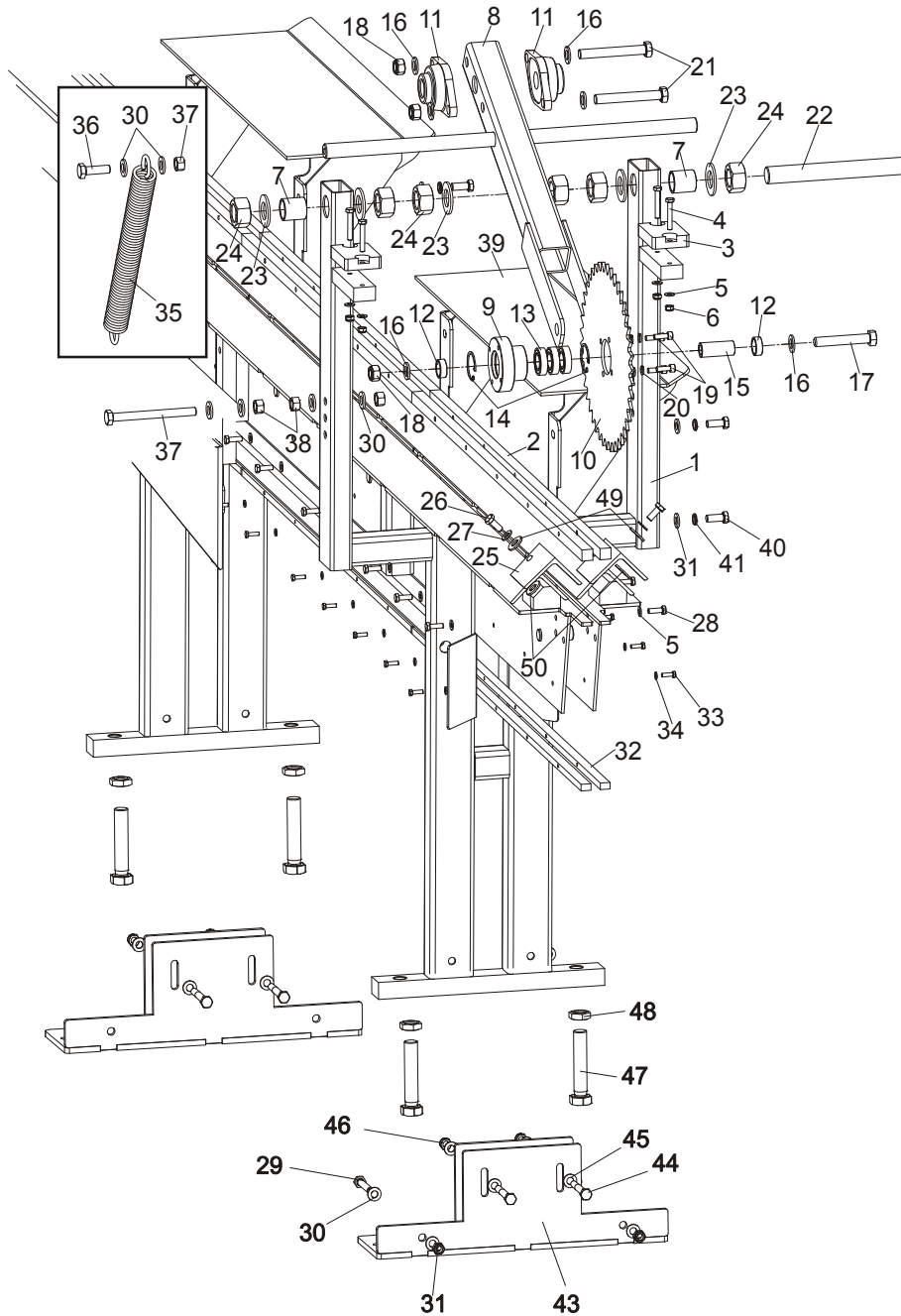

REF	DESCRIPTION (◆ Indicates Parts Available In Assemblies Only)	PART #	QTY.	
	INFEED, TVSIV2.4I	098946	1	
	INFEED, TVSIV2.4M	098947	1	
	TVS INFEED, SHORT COMPLETE	097641	1	
1	TVS INFEED, SHORT	097643-1	1	◆



Infeed & Outfeed Tables

TVS Infeed

2	BAR, CHAIN OUTER SLIDE	098652-1	2	
	BAR, CHAIN SLIDE ZINC	096199-1	4	
3	BUMPER, GRENE 70 3201 0010. SHR RUBBER	094969	2	
4	BOLT, M8X50-8.8-HEX HEAD FULL THREAD ZINC	F81002-19	4	
5	WASHER, M8 FLAT ZINC	F81054-1	42	
6	NUT, M8 HEX NYLON LOCK ZINC	F81032-2	4	
7	BUSHING, SPACER ZINC	096355-1	2	
	ARM, COMPLETE ROLLER HOLD-DOWN	096350	1	
8	ARM, ROLLER HOLD-DOWN WLDMT/PTD	096348-1	1	
9	SHAFT, LOG HOLD-DOWN WHEEL ZINC-PLATED	096351-1	1	
10	WHEEL, LOG HOLD-DOWN ZINC-PLATED	096352-1	1	
11	BEARING, UCFL 206 CX	090851	2	
12	BUSHING, FI 25,5 X 32X12- SPACER ZINC	097942-1	2	
13	BEARING, 6005 2RS CX	089652	3	
14	RING, W47 SPRING RETAINING	089653	2	
15	BUSHING, FI 25X16,5X60 -SPACER ZINC	098610-1	1	
16	WASHER, M16 FLAT ZINC	F81058-1	6	
17	BOLT, M16X100MM HEX HEAD FULL THRD ZINC	F81006-2	1	
18	NUT, M16 HEX NYLON ZINC LOCK	F81036-2	3	
19	BOLT, M8x25 -8.8- HEX SOCKET HEAD CAP	F81002-21	4	
20	WASHER, 8,2 SPLIT LOCK ZINC	F81054-4	4	
21	BOLT, M16x120 -8.8- A2E ISO 24014	F81006-25	2	
22	ROD, M30 (690) HOLD-DOWN ARM THREATED ZINC	096344-1	1	
23	WASHER, 31 FLAT ZINC	F81061-9	6	
24	NUT, M30 HEX ZINC	F81038-3	6	
25	ANGLE, TVS INFEED SHORT PTD	098325-1	2	
26	Bolt, M10-1.5x25mm HH Gr8.8	F81003-11	2	
27	WASHER, M10 FLAT ZINC	F81055-1	2	
28	BOLT, M8 x 25mm HEX HEAD GR 5.8 ZINC	F81002-5	38	
29	BOLT, M12x75-8.8- HEX HEAD FULL THREAD ZINC	F81004-10	2	
30	WASHER, M12 FLAT ZINC	F81056-1	32	
31	NUT, M12 HEX NYLON ZINC LOCK	F81034-2	2	
32	BAR, CHAIN SUPPORT	098942-1	6	
33	BOLT, M6X20MM, HH FULL THREAD ZINC	F81001-2	30	
34	WASHER, M6 FLAT ZINC	F81053-1	30	
35	SPRING, FI 4,5X FI 35X303	091863	2	
36	BOLT, M12x40 8.8 HEX HEAD FULL THR.ZINC	F81004-4	2	
37	BOLT, M12x130 8.8 HEX HEAD FULL THR.ZINC	F81004-55	2	
38	NUT, M12, HEXAGON, GRADE 5.8, ZINC	F81034-1	8	
43	LEG, TVS	099534-1	2	
44	BOLT, M12X90-8.8 HEX HEAD ZINC	F81004-2	2	
45	WASHER, M12 , FLAT, ZINC	F81056-1	4	
46	NUT, M12-8 , HEX, NYLON, ZINC, LOCK	F81034-2	2	
47	BOLT M24X120 8.8 FE/ZN5	F81009-6	2	
48	NUT M24-04-B	F81039-3	2	
49	WASHER, 10.5X19X0.5 FLAT	100623	2	
50	WASHER, 10.5X19X1 FLAT	100624	2	
	INFEED, TVSIV3.6I	098948	1	

	INFEED, TVSIV3.6M	098949	1	
	TVS INFEED, LONG COMPLETE	098747	1	
1	TVS INFEED, LONG	098742-1	1	◆
2	BAR, CHAIN OUTER SLIDE - ZINC	098652-1	2	
	BAR, CHAIN SLIDE - ZINC	096199-1	6	
3	BUMPER, -GRENE 70 3201 0010. SHR RUBBER	094969	2	
4	BOLT, M8X50-8.8-HEX HEAD FULL THREAD ZINC	F81002-19	4	
5	WASHER, M8 FLAT ZINC	F81054-1	42	
6	NUT, M8 HEX NYLON LOCK ZINC	F81032-2	4	
7	BUSHING, SPACER ZINC	096355-1	2	
	ARM, COMPLETE ROLLER HOLD-DOWN	096350	1	
8	ARM, ROLLER HOLD-DOWN WLDMT/PTD	096348-1	1	
9	SHAFT, LOG HOLD-DOWN WHEEL ZINC-PLATED	096351-1	1	
10	WHEEL, LOG HOLD-DOWN ZINC-PLATED	096352-1	1	
11	BEARING, UCFL 206 CX	090851	2	
12	BUSHING, FI 25,5 X 32X12-SPACER ZINC	097942-1	2	
13	BEARING, 6005 2RS CX	089652	3	
14	RING, W47 SPRING RETAINING	089653	2	
15	BUSHING, FI 25X16,5X60 -SPACER ZINC	098610-1	1	
16	WASHER, M16 FLAT ZINC	F81058-1	6	
17	BOLT, M16X100MM HEX HEAD FULL THRD ZINC	F81006-2	1	
18	NUT, M16 HEX NYLON ZINC LOCK	F81036-2	3	
19	BOLT, M8x25 -8.8- HEX SOCKET HEAD CAP	F81002-21	4	
20	WASHER, 8,2 SPLIT LOCK ZINC	F81054-4	4	
21	BOLT, M16x120 -8.8- A2E ISO 24014	F81006-25	2	
22	ROD, M30 (690) HOLD-DOWN ARM THREADED ZINC	096344-1	1	
23	WASHER, 31 FLAT ZINC	F81061-9	6	
24	NUT, M30 HEX ZINC	F81038-3	6	
25	ANGLE, TVS INFEED SHORT PTD	098325-1	2	
26	Bolt, M10-1.5x25mm HH Gr8.8	F81003-11	2	
27	WASHER, M10 FLAT ZINC	F81055-1	2	
28	BOLT, M8 x 25mm HEX HEAD GR 5.8 ZINC	F81002-5	38	
29	BOLT, M12x75-8.8-HEX HEAD FULL THREAD ZINC	F81004-10	2	
30	WASHER, M12 FLAT ZINC	F81056-1	32	
31	NUT, M12 HEX NYLON ZINC LOCK	F81034-2	2	
32	BAR, CHAIN SUPPORT	098942-1	8	
33	BOLT, M6X20MM HH FULL THREAD ZINC	F81001-2	38	
34	WASHER, M6 FLAT ZINC	F81053-1	38	
35	SPRING, FI 4,5X FI 35X303	091863	2	
36	BOLT, M12x40 8.8 HEX HEAD FULL THR.ZINC	F81004-4	2	
37	BOLT, M12x130 8.8 HEX HEAD FULL THR.ZINC	F81004-55	2	
38	NUT, M12, HEXAGON, GRADE 5.8, ZINC	F81034-1	8	
43	LEG, TVS	099534-1	2	
44	BOLT, M12X90-8.8 HEX HEAD ZINC	F81004-2	2	
45	WASHER, M12, FLAT, ZINC	F81056-1	4	
46	NUT, M12-8, HEX, NYLON, ZINC, LOCK	F81034-2	2	
47	BOLT M24X120 8.8 FE/ZN5	F81009-6	2	
48	NUT M24-04-B	F81039-3	2	

5 Infeed & Outfeed Tables

TVS Infeed

49	WASHER, 10.5X19X0.5 FLAT	100623	2	
50	WASHER, 10.5X19X1 FLAT	100624	2	
39	TABLE, TVS SIDE	098115-1 ¹	2/4	
40	BOLT, M12x30-8.8	F81004-22	16	
41	WASHER, M12 SPLIT LOCK ZINC	F81056-2	16	
42	TABLE, LOG RAMP COMPLETE	098340 ²	1	

¹ 2 pcs with I-version table (in line), 4pcs with M-version table (manual).

² Only with I-version table (in line).

5.2 Infeed table chain tension wheel

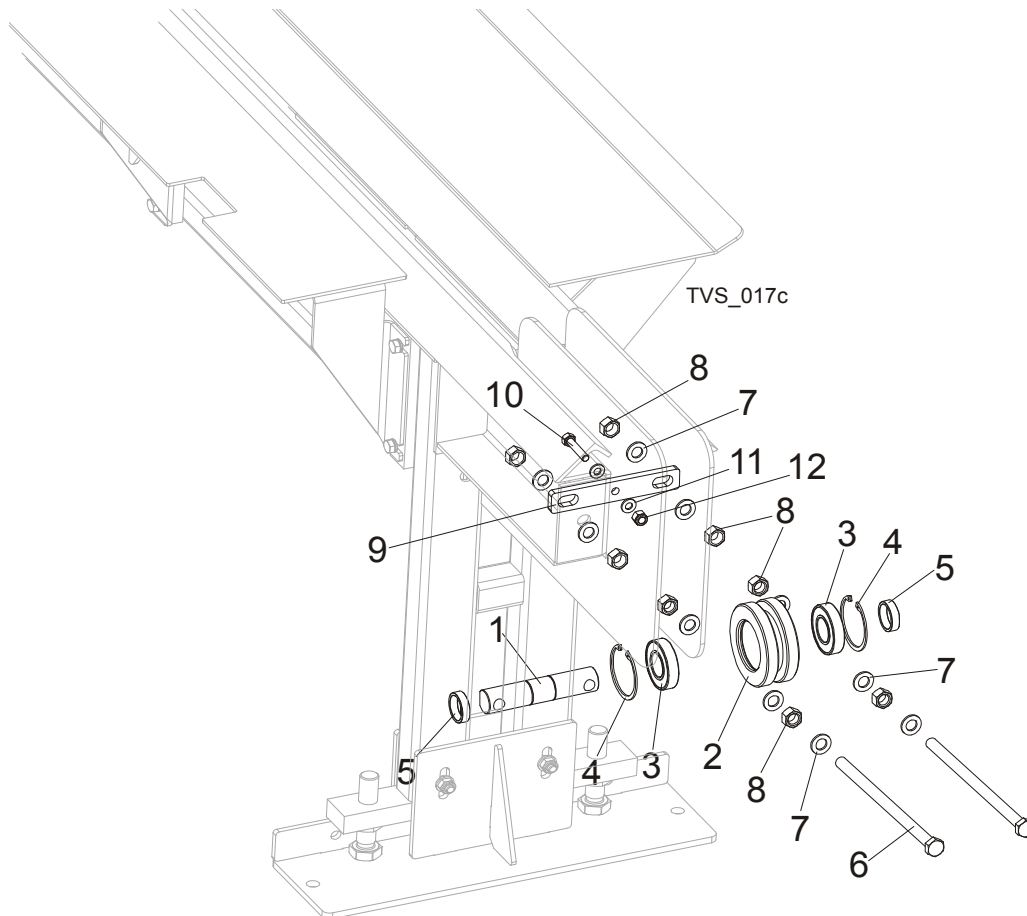

REF	DESCRIPTION (◆ Indicates Parts Available In Assemblies Only)	PART #	QTY.
	CHAIN TENSION WHEEL COMPLETE	097655	1
1	SHAFT, CHAIN TENSION WHEEL	096207-1	1
2	WHEEL, TVS CHAIN TENSION	096208-1	1
3	BEARING, 6207-2RS, C3, 35X72X17	014811	2
4	RING, W72 SPRING RETAINING	F81090-4	2
5	BUSHING, FI 36 X 44 X 12 -SPACER ZINC	096602-1	2
6	BOLT, M16X290-8.8 -A2 HEX HEAD FULL THREAD ZINC	F81006-27	2
7	WASHER, M16 FLAT ZINC	F81058-1	8
8	NUT, M16 HEX GRADE 5.8 PLAIN	F81036-1	8
	SCRAPER, TVS TENSIONING WHEEL, COMPLETE	100752	1
9	HOLDER, TENSIONING WHEEL SCRAPER	100751-1	1
10	BOLT, M10X40-8.8	F81003-16	1
11	WASHER, 10.5 FLAT ZINC	F81055-1	2
12	NUT, M10-8-B NYLON HEX ZINC LOCK	F81033-1	1

5.3 Chain Drive Assembly, TVS

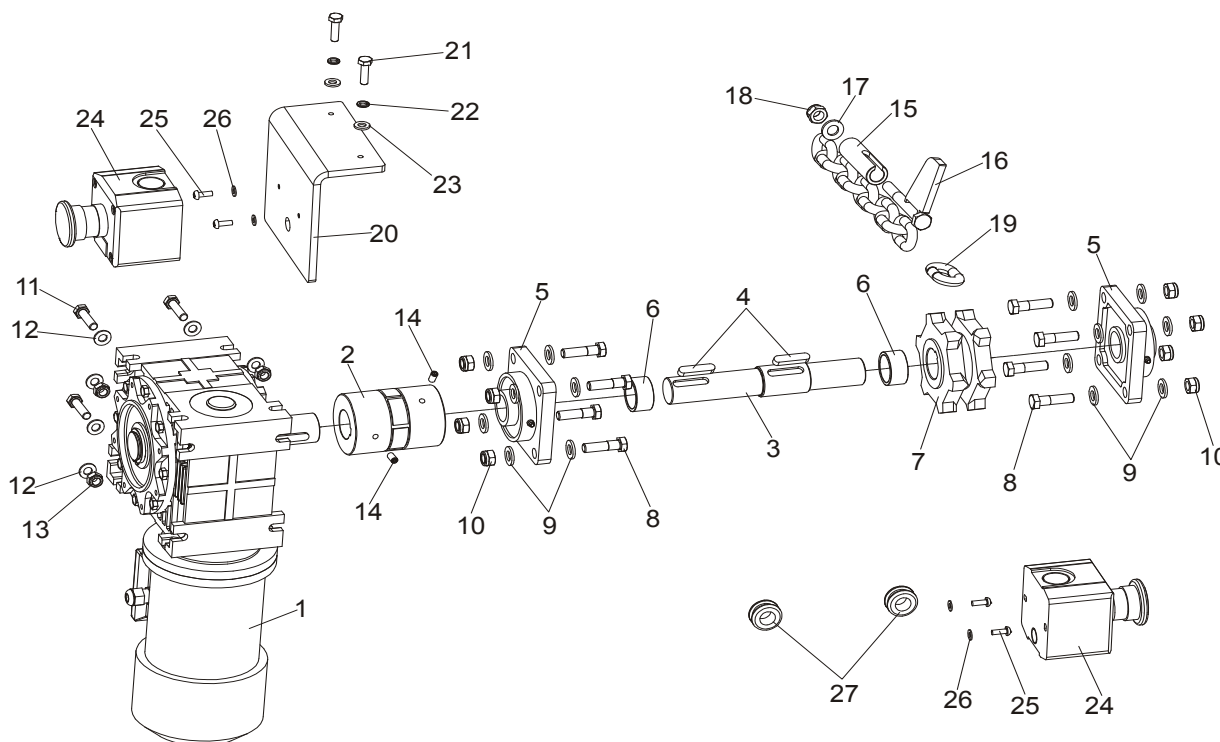

REF	DESCRIPTION (◆ Indicates Parts Available In Assemblies Only)	PART#	QTY.
	CHAIN DRIVE ASSY, TVS COMPLETE	098671	1
1	MOTOREDUCER, MR-80/64/1.1-1400/K3/V6	098663	1
2	COUPLING, "ROTEX-38 ST 92 1A 38X45, 1A 35X45	098664	1
	CONNECTING ELEMENT, 38-92 SHA 098664 COUPLER	505216-S	1
3	SHAFT, TVS CHAIN DRIVE ZINC-PLATED	096203-1	1
4	KEY, A10x8x45 PARALLEL	091312	2
5	BEARING, UCF 207 W/HOUSING	097668	2
6	BUSHING, $\phi 36 \times \phi 44 \times 22$ -SPACER ZINC	099959-1	2
7	SPROCKET, 16B 20Z	097657	1
8	BOLT, M12x45-8.8-HEX HEAD ZINC	F81004-32	8
9	WASHER, M12 FLAT ZINC	F81056-1	16
10	NUT, M12 HEX NYLON ZINC LOCK	F81034-2	8
11	BOLT, M10x40-8.8 HEX HEAD FULL THREAD ZINC	F81003-16	4
12	WASHER, M10 FLAT ZINC	F81055-1	8
13	NUT, M10, NYLON HEX ZINC LOCK	F81033-1	4
14	SCREW, M8x16-33H HEX SOCKED FLAT POINT SET	F81014-2	2

15	COMPLETE CHAIN W/DOGS L.12763	097650 ¹	1	
	Chain, TVS welded	097649-1	1	
	CHAIN, L.13321 W/DOGS	098809 ²	1	
	Chain, welded	098808-1	1	
	COMPLETEL.16359 CHAIN W/DOGS	098987 ³	1	
	Chain, welded	098986-1	1	
	CHAIN, L.18529 W/DOGS	098812 ⁴	1	
	Chain, welded	098811-1	1	
16	Dog	097647-1	6-9 ⁵	
17	WASHER, M12 FLAT ZINC	F81056-1	1	
18	NUT, M12 HEX NYLON ZINC LOCK	F81034-2	1	
19	LINK, CHAIN MASTER	098661	1	
20	BRACKET, EMERGENCY SWITCH TVS	098814-1	1	
21	BOLT, M6X20MM HH FULL THREAD ZINC	F81001-2	2	
22	WASHER, M6 SPLIT LOCK ZINC	F81053-3	2	
23	WASHER, M6 FLAT ZINC	F81053-1	2	
24	SWITCH, EMERGENCY XALJ174F	E22703-P	2	
25	SCREW, M4X12-5,8-B CROSS RECESSED PAN	F81011-43	4	
26	WASHER, 4,3 FLAT ZINC	F81051-2	4	
27	GROMMET, 20/13 RUBBER	086188	2	

¹ Occurs in combination: Short Infeed + Short Outfeed.

² Occurs in combination: Short Infeed + Medium Outfeed.

³ Occurs in combination: Short Infeed + Long Outfeed and Long Infeed + Medium Outfeed.

⁴ Occurs in combination: Long Infeed + Long Outfeed.

⁵ Dogs amount depend on chain type.

5.4 Chain Drive Assembly, "Heavy Duty" Option

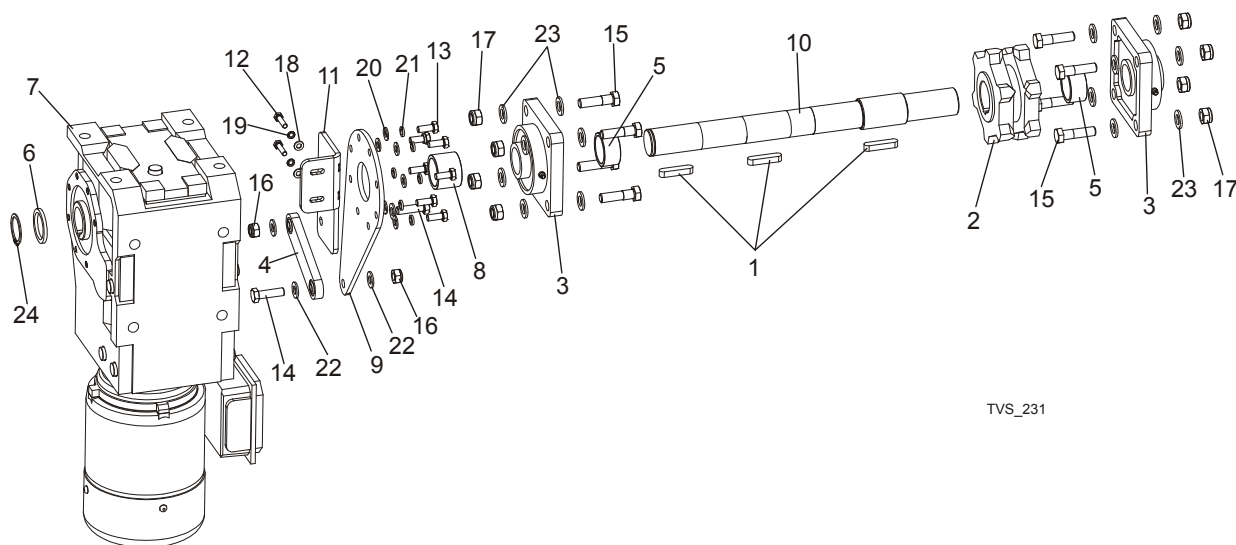

REF	DESCRIPTION (◆ Indicates Parts Available In Assemblies Only)	PART#	QTY.
	CHAIN DRIVE ASSY, "HEAVY DUTY" OPTION COMPLETE	504650	1
	CHAIN DRIVE ASSY, "HEAVY DUTY" OPTION COMPLETE	505020-S ¹	1
1	KEY, A10x8x45 PARALLEL	091312	3
2	SPROCKET, 16B 20Z	097657	1
3	BEARING, UCF 207 W/HOUSING	097668	2
4	LINK, SBPL 10104PIVOTAL	097700	1
5	BUSHING, $\phi 36 \times \phi 44 \times 22$ -SPACER ZINC	099959-1	2
6	SPACER, ZINC	504639-1	1
7	MOTOREDUCER SK9022.IAXZH-80L/4	504640	1
8	SPACER, $\phi 45 \times \phi 36 \times 32,5$ ZINC	504646-1	1
9	PLATE, REACTION	504647-1	1
10	SHAFT, TVS CHAIN DRIVE ZINC-PLATED	504648-1	1
11	BRACKET, REACTION PLATE	504649-1	1
12	BOLT, M6X25MM,HEX HEAD,GR 8.8,ZINC	F81001-3	2
13	BOLT, M8x20-8.8-B HEX HEAD FULL THREAD	F81002-4	7
14	BOLT, M10X35-8.8 HEX HEAD FULL THREAD ZINC	F81003-17	2
15	BOLT, M12X45-8.8	F81004-32	8
16	NUT, M10-8-B HEX NYLON ZINC LOCK	F81033-1	2
17	NUT, M12-8 HEX NYLON ZINC LOCK	F81034-2	8
18	WASHER, 6.4 FLAT ZINC	F81053-1	2
19	WASHER, Z6.1 SPLIT LOCK ZINC	F81053-3	2
20	WASHER, 8.4 FLAT ZINC	F81054-1	7
21	WASHER, 8.2 ZINC	F81054-4	7
22	WASHER, 10.5 FLAT ZINC	F81055-1	4
23	WASHER, 13 FLAT ZINC	F81056-1	16
24	RING, Z35 RETAINING	F81090-36	1

¹ Service Kit to replace standard 098671 chain drive assembly for more durable.

5.5 TVS Outfeed

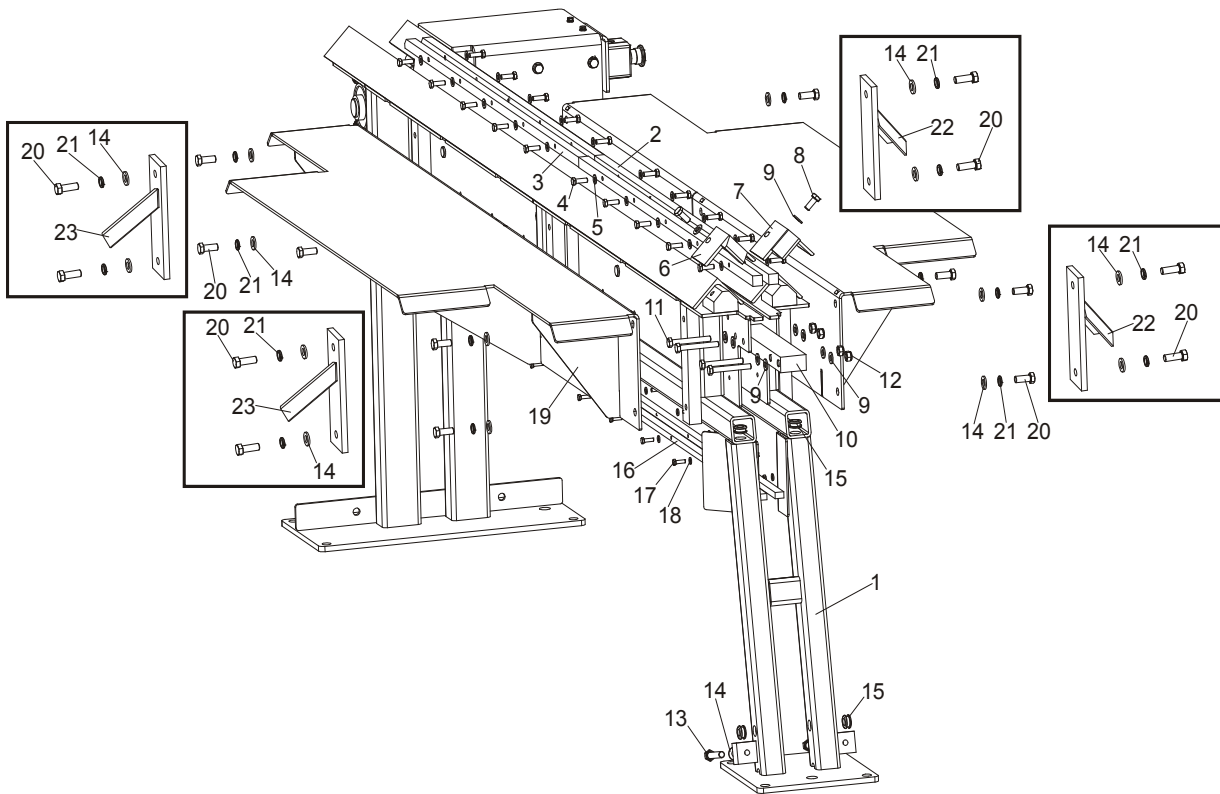

REF	DESCRIPTION (◆ Indicates Parts Available In Assemblies Only)	PART#	QTY.
	OUTFEED, TVSOV2.4I	098950	1
	OUTFEED, TVSOV2.4M	098951	1
	ADDITIONAL HOLD-DOWN ROLLER KIT, TVS 2.4 See Section 5.6	101457	1
	OUTFEED TABLE, TVS COMPLETE	097642	1
1	TABLE, TVS OUTFEED	097644-1	1
2	BAR, CHAIN SLIDE-ZINC	096199-1	2
3	BAR, CHAIN OUTER SLIDE -ZINC	098652-1	2
4	BOLT, M8 x 25mm HEX HEAD GR 5.8 ZINC	F81002-5	20
5	WASHER, M8 FLAT ZINC	F81054-1	20
6	BLOCK, GUIDE WLDMT/PTD - LEFT	098315-1	1
7	BLOCK, GUIDE WLDMT/PTD - RIGHT	098670-1	1
8	Bolt, M10-1.5x25mm HH Gr8.8	F81003-11	2
9	WASHER, M10 FLAT ZINC	F81055-1	10
10	CONNECTOR, TABLE ZINC-PLATED	098667-1	1
11	BOLT, M10x80 -8.8- HEX HEAD ZINC	F81003-50	4
12	NUT, M10 NYLON HEX ZINC LOCK	F81033-1	4
13	BOLT, M12x75-8.8-HEX HEAD ZINC	F81004-21	2
14	WASHER, M12 FLAT ZINC	F81056-1	14
15	GROMMET, 20/13 RUBBER	086188	4
16	BAR, CHAIN SUPPORT	098942-1	4
17	BOLT, M6X20MM HH FULL THREAD ZINC	F81001-2	20
18	WASHER, M6 FLAT ZINC	F81053-1	20

19	TABLE, SIDE PTD	097932-1	2	
20	BOLT, M12x30-8.8	F81004-22	8/12 ¹	
21	WASHER, M12 SPLIT LOCK ZINC	F81056-2	8/12 ¹	
22	ANGLE, BOARD REMOVAL LEFT	097885-1 ²	2	
23	ANGLE, BOARD REMOVAL RIGHT	097886-1 ²	2	
	OUTFEED, TVSOV3.6I	098952	1	
	OUTFEED, TVSOV3.6M	098953	1	
	ADDITIONAL HOLD-DOWN ROLLER KIT, TVS 3.6 See Section 5.6	101458	1	
	OUTFEED, MEDIUM COMPLETE	098755	1	
1	OUTFEED, TVS MEDIUM	098754-1	1	
2	BAR, CHAIN SLIDE - ZINC	096199-1	2	
3	BAR, CHAIN OUTER SLIDE - ZINC	098652-1	2	
	BAR, CHAIN SHORT SLIDE- ZINC	098753-1	2	
4	BOLT, M8 x 25mm HEX HEAD GR 5.8 ZINC	F81002-5	28	
5	WASHER, M8 FLAT ZINC	F81054-1	28	
6	BLOCK, GUIDE WLDMT/PTD - LEFT	098315-1	1	
7	BLOCK, GUIDE WLDMT/PTD - RIGHT	098670-1	1	
8	Bolt, M10-1.5x25mm HH Gr8.8	F81003-11	2	
9	WASHER, FLAT, M10, ZINC	F81055-1	10	
10	CONNECTOR, TABLE ZINC-PLATED	098667-1	1	
11	BOLT, M10x80 -8.8- HEX HEAD ZINC	F81003-50	4	
12	NUT, M10, NYLON HEX ZINC LOCK	F81033-1	4	
13	BOLT, M12x75-8.8-HEX HEAD ZINC	F81004-21	2	
14	WASHER, M12 FLAT ZINC	F81056-1	14	
15	GROMMET, 20/13 RUBBER	086188	4	
16	BAR, CHAIN SUPPORT	098942-1	4	
	BAR, CHAIN SHORT SUPPORT	098943-1	2	
17	BOLT, M6X20MM, HH, FULL THREAD, ZINC	F81001-2	28	
18	WASHER, M6 FLAT ZINC	F81053-1	28	
19	TABLE, SIDE	097932-1	2	
20	BOLT M12x30-8.8	F81004-22	8/12 ¹	
21	WASHER, M12 SPLIT LOCK ZINC	F81056-2	8/12 ¹	
22	ANGLE, BOARD REMOVAL LEFT	097885-1 ²	2	
23	ANGLE, BOARD REMOVAL RIGHT	097886-1 ²	2	
	OUTFEED, TVSOV4.8I	098954	1	
	OUTFEED, TVSOV4.8M	098955	1	
	ADDITIONAL HOLD-DOWN ROLLER KIT, TVS 4.8 See Section 5.6	101459	1	
	OUTFEED, TVS LONG COMPLETE	098796	1	
1	OUTFEED, TVS	098795-1	1	
2	BAR, CHAIN SLIDE -ZINC	096199-1	4	
3	BAR, CHAIN OUTER SLIDE -ZINC	098652-1	2	
	BAR, CHAIN SHORT SLIDE -ZINC	098753-1	2	
4	BOLT, M8 x 25mm HEX HEAD GR 5.8 ZINC	F81002-5	36	
5	WASHER, M8 FLAT ZINC	F81054-1	36	
6	BLOCK, GUIDE WLDMT/PTD - LEFT	098315-1	1	
7	BLOCK, GUIDE WLDMT/PTD - RIGHT	098670-1	1	

8	Bolt, M10-1.5x25mm HH Gr8.8	F81003-11	2	
9	WASHER, M10 FLAT ZINC	F81055-1	10	
10	CONNECTOR, TABLE ZINC-PLATED	098667-1	1	
11	BOLT, M10x80 -8.8-HEX HEAD ZINC	F81003-50	4	
12	NUT, M10 NYLON HEX ZINC LOCK	F81033-1	4	
13	BOLT, M12x75-8.8-HEX HEAD ZINC	F81004-21	2	
14	WASHER, M12 FLAT ZINC	F81056-1	14	
15	GROMMET, 20/13 RUBBER	086188	4	
16	BAR, CHAIN SUPPORT	098942-1	6	
	BAR, CHAIN SUPPORT SHORT	098943-1	2	
17	BOLT, M6X20MM HH FULL THREAD ZINC	F81001-2	38	
18	WASHER, M6 FLAT ZINC	F81053-1	38	
19	TABLE, SIDE PTD	097932-1	4	
20	BOLT M12x30-8.8	F81004-22	16/24 ¹	
21	WASHER, M12 SPLIT LOCK ZINC	F81056-2	16/24 ¹	
22	ANGLE, BOARD REMOVAL LEFT	097885-1 ²	4	
23	ANGLE, BOARD REMOVAL RIGHT	097886-1 ²	4	

¹ First number of the fasteners concerns I-version table (in line), second concerns M-version table (manual).

² Only in I-version table (in line).

5.6 Additional Hold-Down Roller Kit

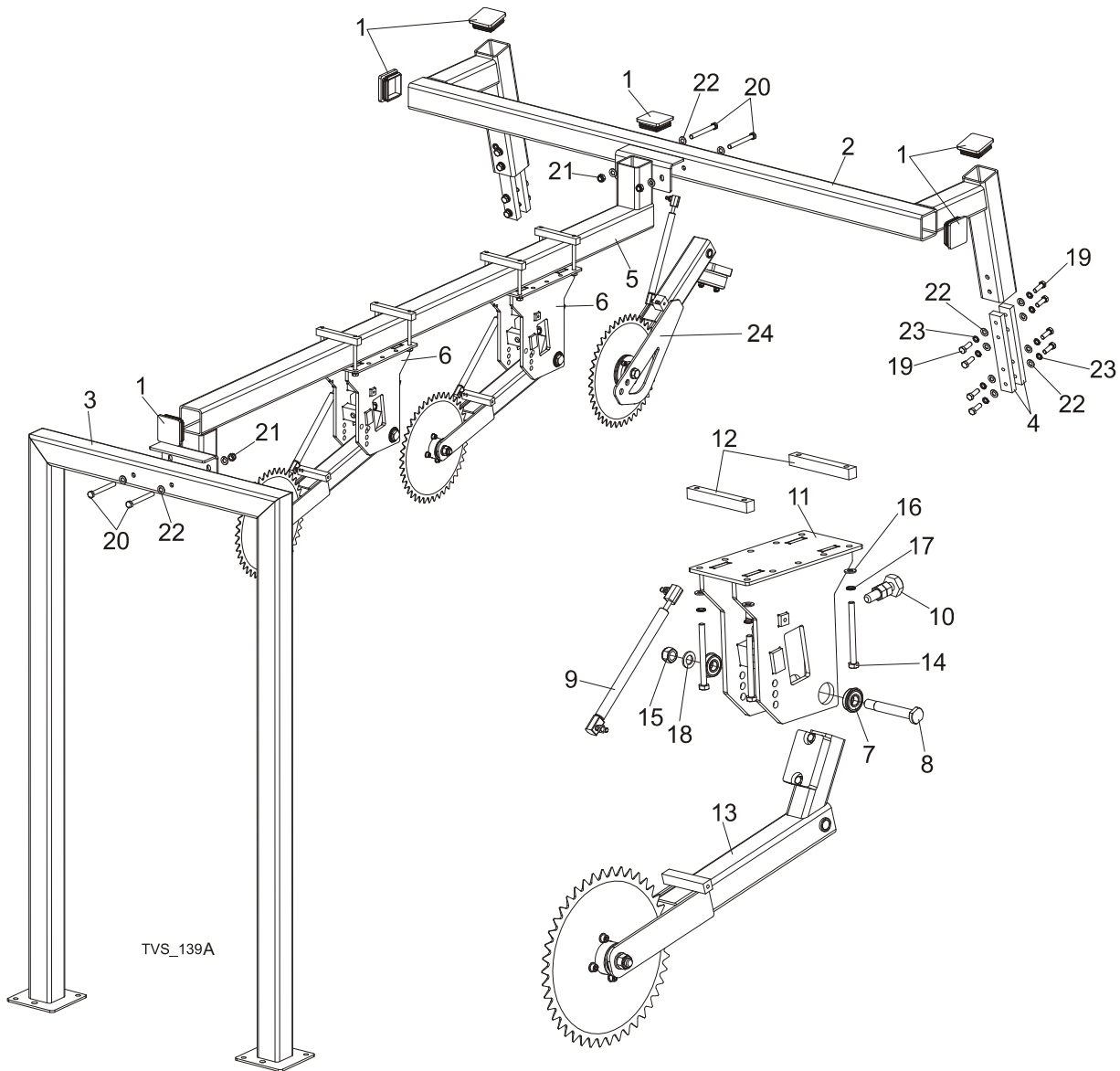

REF	DESCRIPTION (◆ Indicates Parts Available In Assemblies Only)	PART#	QTY.
	ADDITIONAL HOLD-DOWN ROLLER KIT, TVS 2.4	101457	1
	ADDITIONAL HOLD-DOWN ROLLER KIT, TVS 3.6	101458	1
	ADDITIONAL HOLD-DOWN ROLLER KIT, TVS 4.8	101459	1
1	Cap, Hold-Down Roller Frame	089644	6
2	Support Construction, Hold-Down Roller Rear	100731-1	1
3	Frame, Hold-Down Roller Construction Front	100738-1	1
4	Bar, Hold-Down Roller Support Mount	100756-1	4
5	Middle Tube, Hold-Down Roller Construction (Short Table)	101181-1	1
	Middle Tube, Hold-Down Roller Construction (Middle Table)	100945-1	1
	Middle Tube, Hold-Down Roller Construction (Long Table)	101184-1	1
6	Hold-Down Roller, TVS Additional Complete	101450	1/2/3

7	Bearing w/Snap Ring LT15 6203-2RS	086395	2	
8	Bolt, Arm Bearnig Mount	086404	1	
9	Spring, 340N Gas Complete	089212	1	
10	M16 Bolt & 2 Nuts	093710	1	
11	Support, Hold-Down Roller Upper	100746-1	1	
12	Bar, Hold-Down Roller Support Mount	100757-1	2	
13	Roller, TVS Hold-Down Additional	100973	1	
14	Bolt, M10 X 115-8.8 Zinc Lock	F81003-19	4	
15	Nut, M16 Hex Nylon Zinc Lock	F81036-2	1	
16	Washer, 10.5 Flat Zinc	F81055-1	4	
17	Washer, 10.2 Split Lock Zinc	F81055-2	4	
18	Washer, 17 Flat Zinc	F81058-1	1	
19	Bolt, M12x35-8.8 Zinc Hex Head Full	F81004-24	16	
20	Bolt, M12x110-8.8 Zinc Hex Head Full	F81004-47	4	
21	Nut, M12-8 Hex Nylon Zinc Lock	F81034-2	4	
22	Washer, 13 Flat Zinc	F81056-1	24	
23	Washer, Z12.2 Split Lock Zinc	F81056-2	16	
24	ROLLER, HOLD-DOWN TVS (See Section 4.9)	097954	1	

5.7 Tables Decals

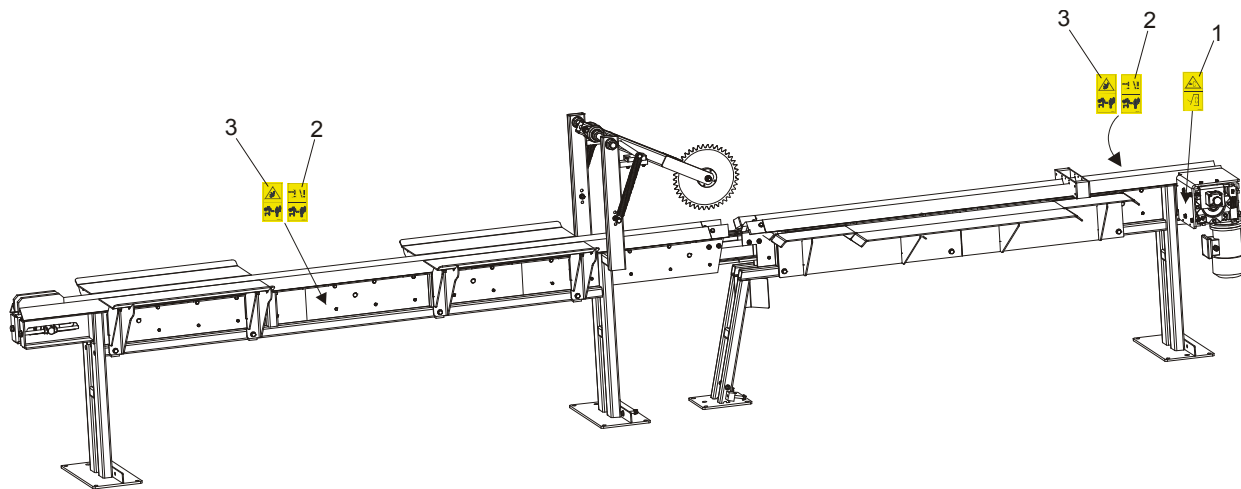

REF	DESCRIPTION (◆ Indicates Parts Available In Assemblies Only)	PART#	QTY.
	DECALS KIT, PICTOGRAMS, INFEED&OUTFEED TABLES	099580	1
1	Decal, Close guards prior to operating the machine	099220	1
2	Decal, keep all persons a safe distance	096314	2
3	Decal, keep a safe distance	099221	2

SECTION 6 INCLINE LOG DECK

6.1 Infeed Assembly

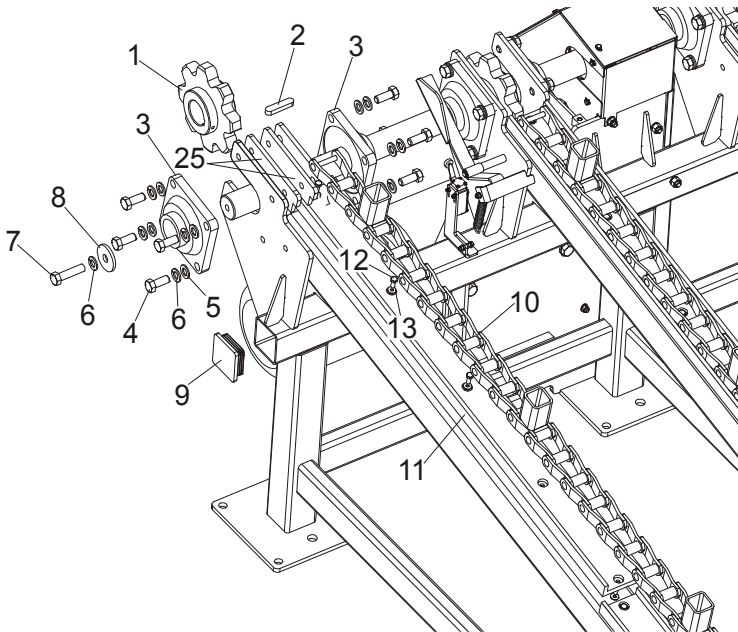

TVS_039_A

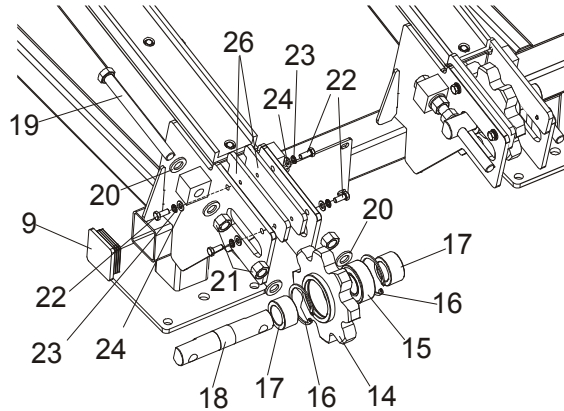

REF.	DESCRIPTION (◆ Indicates Parts Available In Assemblies Only)	PART #	QTY.
	TVS, SHS INCLINE LOG DECK	508705	1
	TVS INCLINE LOG DECK	LD3	1
1	SPROCKET, Z8 OXIDIZED	089888-1	4
2	KEY, A16X10X70 PARALLEL	098029	4
3	BEARING, UCF 211W/HOUSING (55 DIA. SHAFT)	089889	8
4	BOLT, M16x45-8.8 HEX HEAD FULL THREAD ZINC	F81006-46	32
5	WASHER, 17 FLAT ZINC	F81058-1	48
6	WASHER, 16.3 SPLIT LOCK ZINC	F81058-2	48
7	BOLT, M16x65-8.8-B HEX HEAD FULL THREAD ZINC	F81006-1	4
8	WASHER, TVS SPECIAL	098012-1	2
9	CAP, FRAME TUBE	089644	4

10	CHAIN, TVS INCLINE LOG DECK 5940mm 89-LINK	504582	4
11	CHANNEL, UHMW CONVEYOR	033722	8
12	BOLT, M8x20-5.8 HEX HEAD FULL THREAD ZINC	F81002-1	40
13	WASHER, 6.5 SPECIAL FLAT ZINC	F81053-11	40
14	SPROCKET, Z8 REAR OXIDIZED	089919-1	4
15	BEARING, 3208B.2RSR.TVH FAG	088449	4
16	RING, W80 INSIDE RETAINING	F81090-25	8
17	BUSHING, SPROCKET SPACER	089916-1	8
18	SHAFT, CHAIN TENSION SPROCKET	089915-1	4
19	BOLT, M20x240-8.8 HEX HEAD FULL THREAD ZINC	F81007-1	8
20	WASHER, 21 FLAT ZINC	F81059-2	24
21	NUT, M20-8 HEX ZINC	F81037-1	16
22	Bolt, M10x25-8.8 HEX HEAD FULL THREAD ZINC	F81003-11	16
23	WASHER, 10.2 SPLIT LOCK ZINC	F81055-2	16
24	WASHER, 10.5 FLAT ZINC	F81055-1	16
25	PLATE, DRIVE SIDE, SPACER	509026-1	8
26	PLATE, IDLE SIDE, SPACER	509027-1	8

6.2 Additional Grid, Option For TVS Incline Log Deck

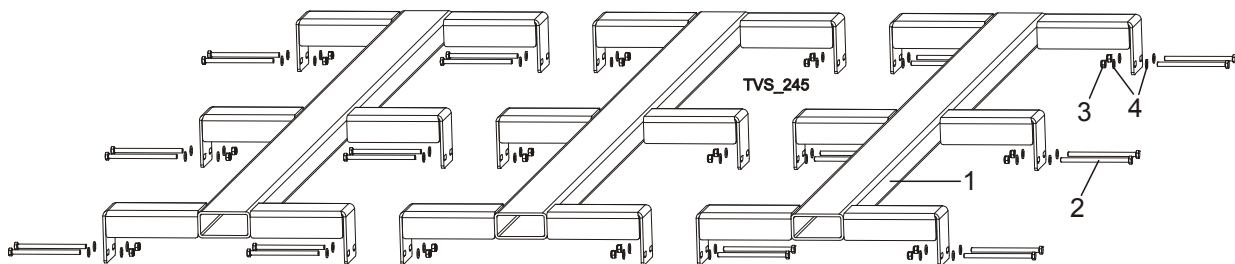

REF.	DESCRIPTION (◆ Indicates Parts Available In Assemblies Only)	PART #	QTY.
	GRID, ADDITIONAL TVS INCLINE LOG DECK - COMPLETE	505855	1
1	GRID, ADDITIONAL TVS INCLINE LOG DECK	505854-1	3
2	BOLT, M8x130-8.8 HEX HEAD ZINC	F81002-50	24
3	NUT, M8-8-B HEX NYLON LOCK ZINC	F81032-2	24
4	WASHER, 8.4 FLAT ZINC	F81054-1	48

6.3 Limit Switch Assembly

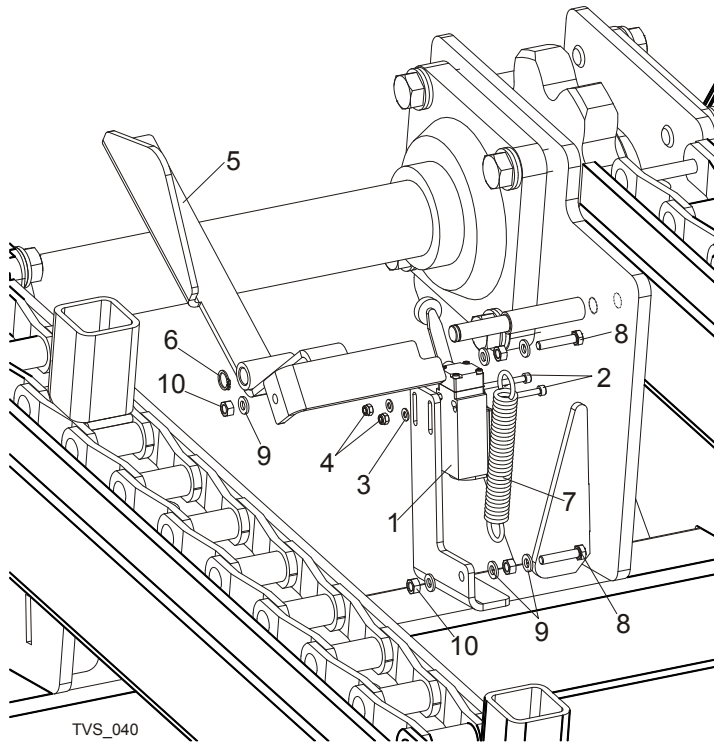

REF.	DESCRIPTION (◆ Indicates Parts Available In Assemblies Only)	PART #	QTY.
1	SWITCH, GLCB01A2B LIMIT	086469	1
2	SCREW, M4X35-8.8 HEX SOCKET HEAD CAP ZINC	F81011-34	2
3	WASHER, 4.3 FLAT ZINC	F81051-2	2
4	NUT, M4-B HEX NYLON LOCK ZINC	F81029-1	2
5	ARM, TVS LIMIT SWITCH ACTIVATOR - COMPLETE	098474-1	1
6	RING, Z12 OUTSIDE RETAINING	F81090-14	1
7	SPRING, FI 1.9 X FI 14.2 X 104	091865	1
8	BOLT, M6X30 5.8 HEX HEAD FULL THREAD	F81001-13	2
9	WASHER, 6.4 FLAT ZINC	F81053-1	6
10	NUT, M6-8 HEX ZINC	F81031-1	4

6.4 Drive Assembly

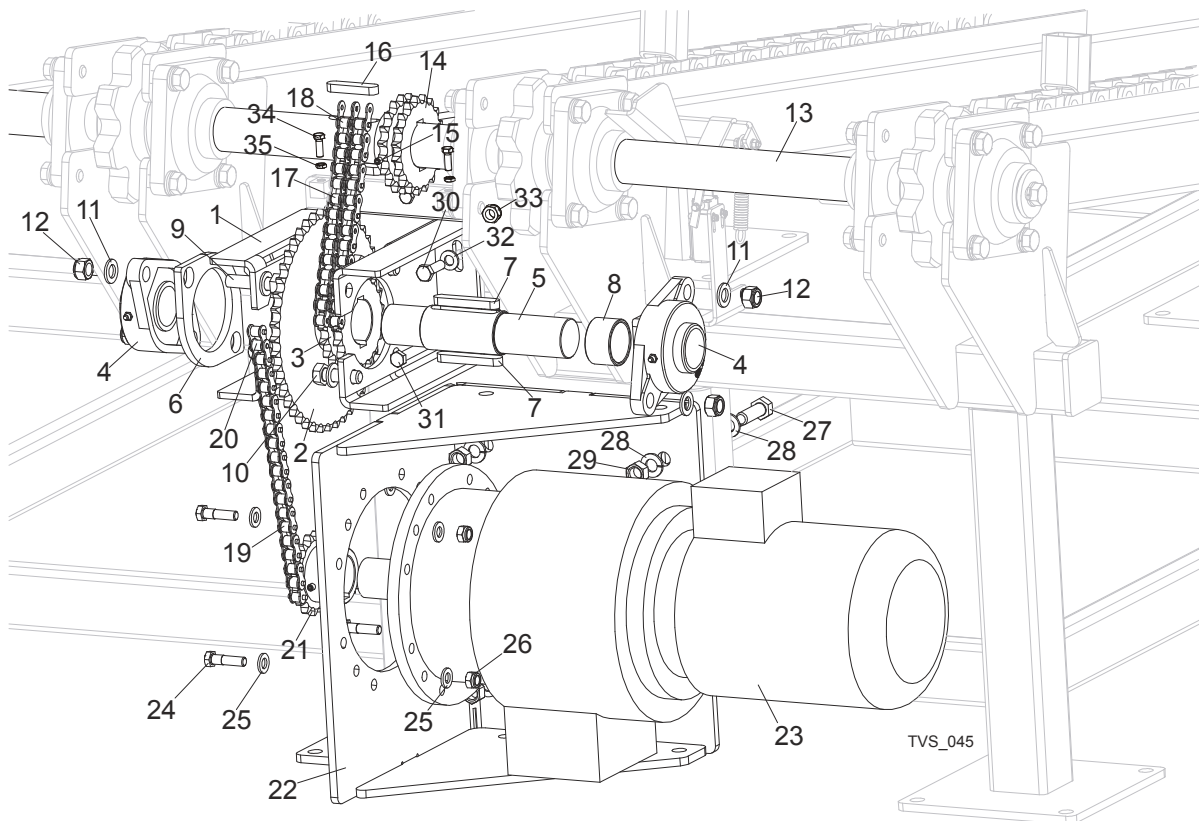

REF.	DESCRIPTION (◆ Indicates Parts Available In Assemblies Only)	PART #	QTY.
	GEAR ASSEMBLY, TVS INCLINE LOG DECK	098424	1
1	BRACKET WELDMENT, TVS SPROCKET MOUNTING	098422-1	1
2	SPROCKET, 12B Z45 OXIDIZED	089894-1	1
3	SPROCKET, 12B Z19	098013-1	1
4	BEARING, UCFL 210 CX W/HOUSING	098824	2
5	SHAFT, INTERMEDIATE SPROCKET ZINC-PLATED	098419-1	1
6	PLATE, FL 210 BEARING SPACER	099106-1	1
7	KEY, A16X10X90 PARALLEL	099131	2
8	SPACER, TVS SPROCKET	098011-1	1
9	BOLT, M16 THIN	099647	2
10	BOLT, M16x50-8.8 HEX HEAD FULL THREAD ZINC	F81006-7	2
11	WASHER, 17 FLAT ZINC	F81058-1	8
12	NUT, M16-8 HEX NYLON LOCK ZINC	F81036-2	4
13	SHAFT, TVS INCLINE LOG DECK MAIN	098010	1
14	SPROCKET, 12B Z19	098013-1	1
15	SCREW, M8X8-33H HEX SOCKET SET FLAT POINT ZINC	F81014-1	4
16	KEY, A16X10X70 PARALLEL	098029	2
17	CHAIN, 12B-2-41 (0.8 RM)	099250	1
18	LINK, 12B-1PZ CHAIN	099249	1

19	CHAIN, 12B-1-65 (1.25 RM)	099248	1	
20	LINK, 12B-1PZ CHAIN	090713	1	
21	SPROCKET, 12B Z16 OXIDIZED	090303-1	1	
22	BRACKET WELDMENT, DECK MOTOR MOUNT	089897-1	1	
23	MOTOREDUCER, SBCM 180/112M-4/32	089892	1	
24	BOLT, M12X45-8.8 HEX HEAD ZINC	F81004-32	4	
25	WASHER, 13 FLAT ZINC	F81056-1	8	
26	NUT, M12-8 HEX NYLON LOCK ZINC	F81034-2	4	
27	BOLT, M16X50-8.8 HEX HEAD FULL THREAD ZINC	F81006-7	4	
28	WASHER, 17 FLAT ZINC	F81058-1	8	
29	NUT, M16-5.8 HEX ZINC	F81036-1	4	
30	BOLT, M12X40-8.8 HEX HEAD FULL THREAD ZINC	F81004-4	2	
31	BOLT, M12X120 8.8 HEX HEAD ZINC	F81004-38	2	
32	WASHER, 13 FLAT ZINC	F81056-1	8	
33	NUT, M12-8-B HEX ZINC	F81034-1	4	
34	BOLT, M10X50-8.8 HEX HEAD FULL THREAD ZINC	F81003-4	2	
35	NUT, M10-8-B HEX ZINC	F81033-3		

6.5 Chain Guards

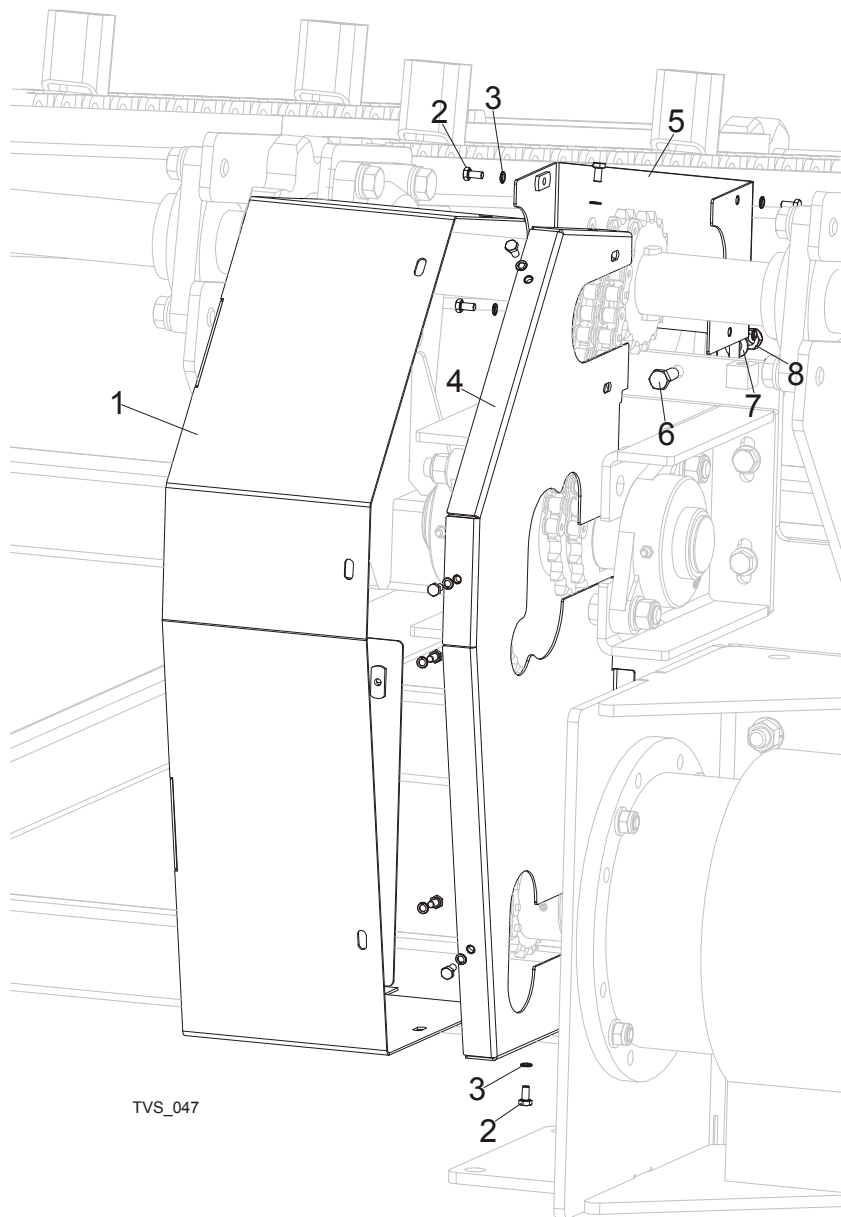

REF.	DESCRIPTION (◆ Indicates Parts Available In Assemblies Only)	PART #	QTY.
1	GUARD, TVS ILD GEAR - MAIN	098467-1	1
2	BOLT, M6X12-8.8 HEX HEAD FULL THREAD ZINC	F81001-7	11
3	WASHER, Z 6.1 SPLIT LOCK ZINC	F81053-3	11
4	GUARD, TVS ILD GEAR - SIDE	098470-1	1
5	GUARD, TVS REAR	098469-1	1
6	BOLT, M10X30-5.8 HEX HEAD FULL THREAD ZINC	F81003-2	1
7	WASHER, 10.5 FLAT ZINC	F81055-1	1
8	NUT, M10-8-B HEX NYLON LOCK ZINC	F81033-1	1

6.6 LD4 Leg Foot Plate

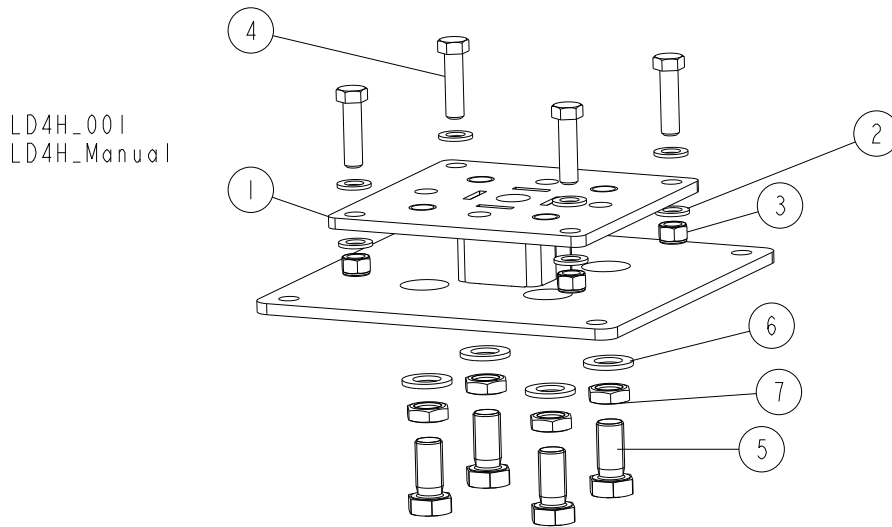

REF.	DESCRIPTION (◆ Indicates Parts Available In Assemblies Only)	PART #	QTY.
	PLATE, LD4 LEG FOOT - COMPLETE	509795	1
1	PLATE WELDMENT, LD4 LEG FOOT	509792-1	1
2	WASHER, 17 SPLIT LOCK ZINC	F81058-1	8
3	NUT, M16-8 HEX NYLON ZINC LOCK	F81036-2	4
4	BOLT, M16X60-8.8 HEX HEAD FULL THREAD ZINC	F81006-12	4
5	BOLT, M24X50 8.8 HEX HEAD FULL THREAD ZINC	F81009-13	4
6	WASHER, 25 FLAT ZINC	F81061-3	4
7	NUT, M24-04-B HEX THIN ZINC	F81039-3	4

6.7 LD4 Log Rest Table

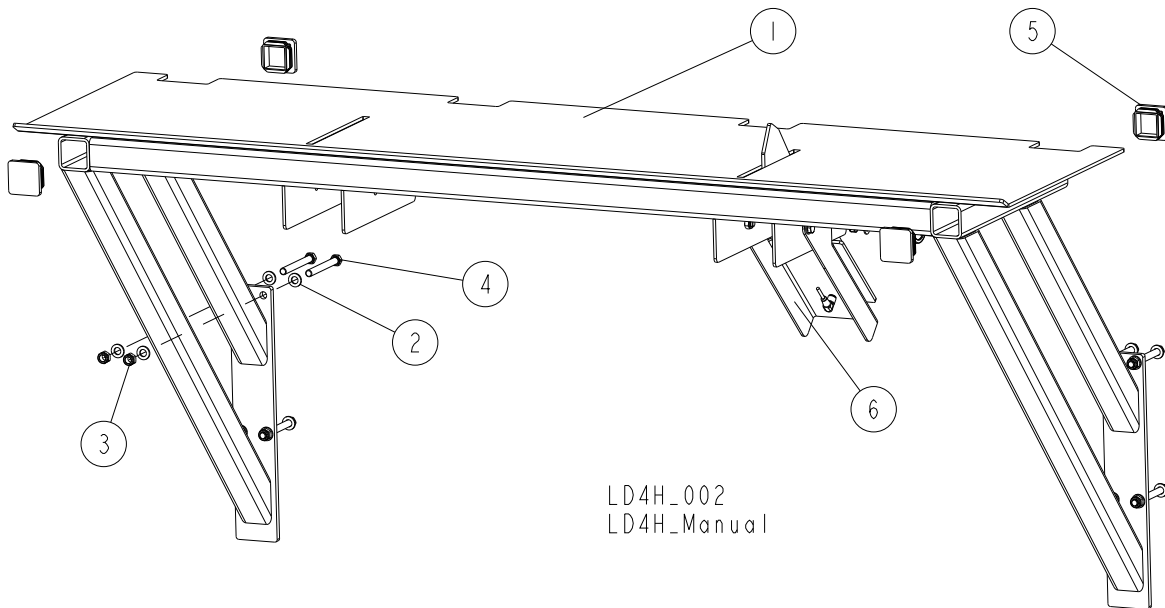

REF.	DESCRIPTION (◆ Indicates Parts Available In Assemblies Only)	PART #	QTY.
	TABLE, LOG REST - COMPLETE	508550	1
1	TABLE, LOG REST	508551-1	1
2	WASHER, 13 FLAT ZINC	F81056-1	16
3	NUT, M12-8 HEX NYLON ZINC LOCK	F81034-2	8
4	BOLT, M12X110-8.8-B HEX HEAD ZINC	F81004-47	8
5	CAP, 60X60 3-4 #199211 TUBE	089710	4
6	LEVER ASSEMBLY, LOG DECK SHUT-OFF See Section 6.8	508559	1

6.8 LD4 Shut-Off Lever Assembly

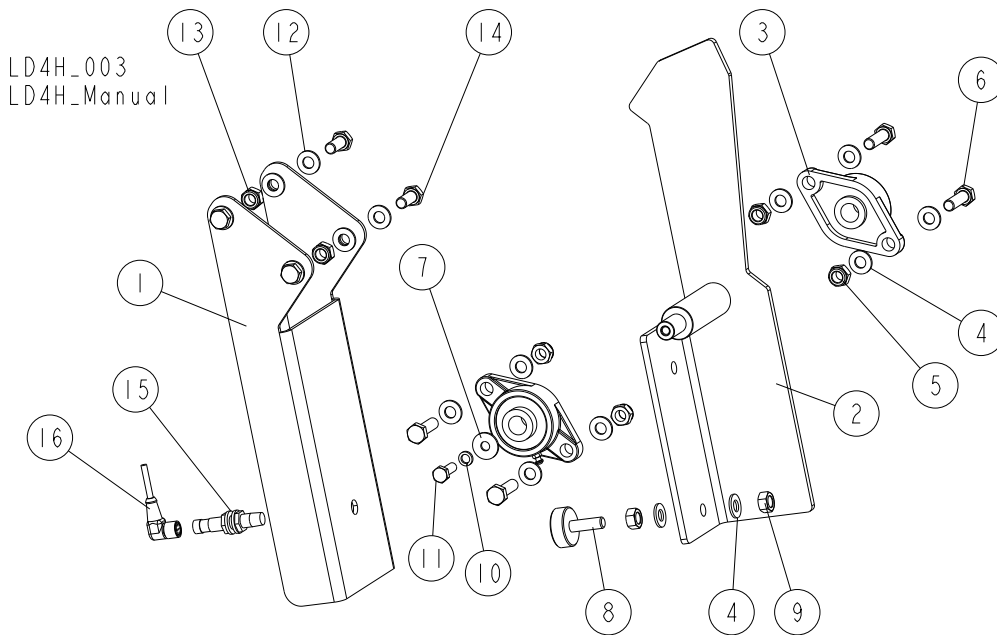

REF.	DESCRIPTION (◆ Indicates Parts Available In Assemblies Only)	PART #	QTY.
	LEVER ASSEMBLY, LOG DECK SHUT-OFF	508559	1
1	PLATE, SHUT-OFF LEVER STOP	508564-1	1
	LEVER, LOG DECK SHUT-OFF - COMPLETE	508646	1
2	LEVER, SHUT-OFF	508560-1	1
3	BEARING, UCFL 203 (CX) W/HOUSING	507347	2
4	WASHER, 10.5 FLAT ZINC	F81055-1	10
5	NUT, M10-8-B HEX NYLON ZINC LOCK	F81033-1	4
6	BOLT, M10X35 8.8 HEX HEAD FULL THREAD ZINC	F81003-17	4
7	WASHER, ISO 7093-1-8-200 HV-A2E	F81054-11	1
8	FOOT, M10 LEG	092839	1
9	NUT, M10 8 HEX ZINC	F81033-3	2
10	WASHER, 8.2 SPLIT LOCK ZINC	F81054-4	1
11	BOLT, M8X25-8.8-B HEX HEAD FULL THREAD ZINC	F81002-5	1
12	WASHER, 10.5 FLAT ZINC	F81055-1	8
13	NUT, M10-8-B HEX NYLON ZINC LOCK	F81033-1	4
14	BOLT, M10X25 8.8 HEX HEAD FULL THREAD ZINC	F81003-11	4
15	SENSOR, BES M12MG-PSC80F-S04G INDUCTIVE PROXIMITY	093168	1
16	CABLE, 10 M 4-WIRE SENSOR	094291	1

6.9 Decals

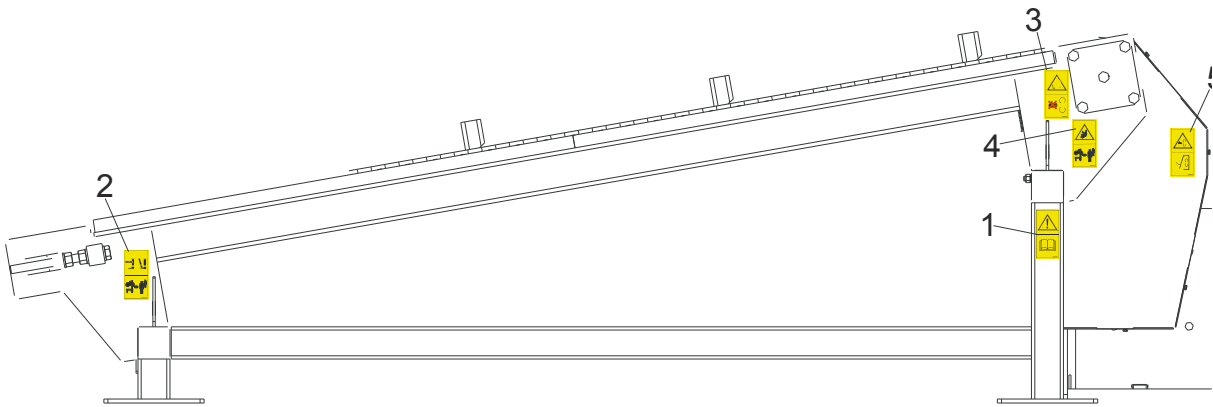

TVS_048

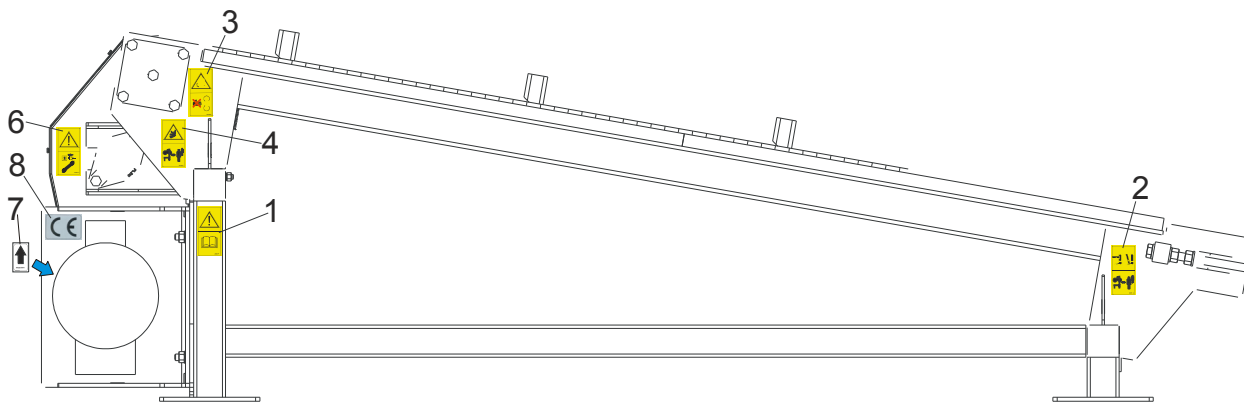

REF.	DESCRIPTION (◆ Indicates Parts Available In Assemblies Only)	PART #	QTY.
	PICTOGRAPHIC DECALS KIT, INCLINE LOG DECK	099579	1
1	Decal, read operator's manual (pictogram)	096317	2
2	Decal, keep away warning (pictogram)	096314	2
3	Decal, gear danger (pictogram)	099540	2
4	Decal, keep away warning (pictogram)	099221	2
5	Decal, close all guards and covers before starting the machine	099220	1
6	Decal, disconnect and lock out power supply before servicing (pictogram)	098177	1
7	Decal, 1400 RPM Motor Direction	S20097H	1
8	DECAL, CE-CERTIFIED SAWMILL	P85070	1

SECTION 7 CROSS TRANSFER DECK

7.1 Front Module & Chains

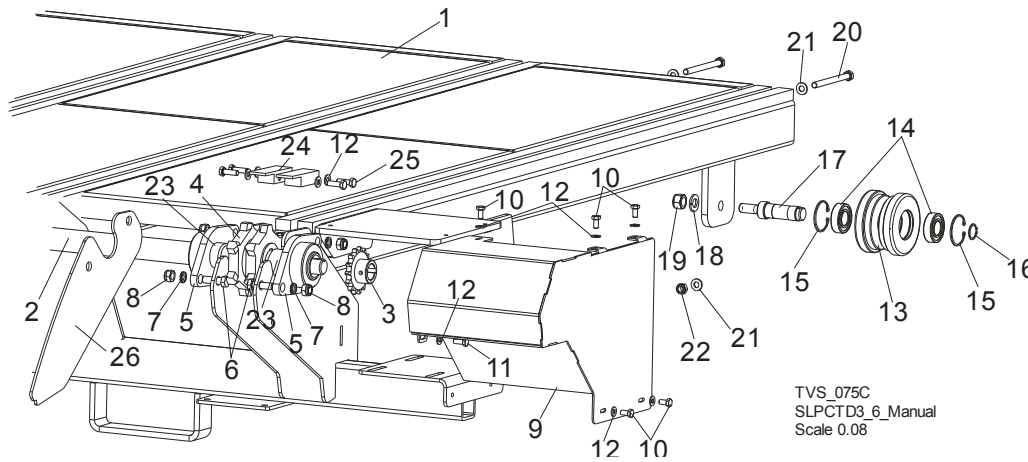

REF	DESCRIPTION (◆ Indicates Parts Available In Assemblies Only)	PART #	QTY
	COMPLETE FRONT MODULE	099556	1
1	FRAME WELDMENT, CTD FRONT	097899-1	1
2	SHAFT, CTD DRIVE	097893	1
3	SPROCKET, 10B Z 15 INCLINE CONVEYOR	095162	1
4	SPROCKET, 16B 20Z	097657	4
5	BEARING, FYTB 40 KG	097898	8
6	BOLT, SPROCKET MOUNTING	091744	16
7	WASHER, 17 FLAT ZINC	F81058-1	16
8	NUT, M16 HEX NYLON ZINC LOCK	F81036-2	16
9	COVER, CTD CHAIN	097903-1	1
10	BOLT, M8x16-8.8 HEX HEAD ZINC	F81002-20	5
11	BOLT, M8X20-8.8-B HEX HEAD FULL THREAD ZINC	F81002-4	1
12	WASHER, 8.4 FLAT, ZINC	F81054-1	22
	WHEEL, CTD COMPLETE	098492	4
13	TENSIONER, CTD CHAIN	098493	1
14	BEARING, SKF 6205-2RS ROLLER	087353	2
15	RING, W52 INSIDE RETAINING	F81090-6	2
16	RING, 25Z OUTSIDE RETAINING	F81090-22	1
17	SHAFT, CTD CHAIN TENSIONER	098494	1
18	WASHER, 16.3 SPLIT LOCK ZINC	F81058-2	4
19	NUT, M16-8 HEX NYLON ZINC LOCK	F81036-2	4
20	BOLT, M10x125-8.8 HEX HEAD ZINC	F81003-18	6
21	WASHER, 10.5 FLAT ZINC	F81055-1	12
22	NUT, M10-8-B HEX NYLON ZINC LOCK	F81033-1	6
23	BUSHING, FI 40 x FI 48x14 SPACER	099958-1	8
24	Bar, Flat	508973-1	8
25	BOLT, M8X25-8.8-B HEX HEAD FULL THRE	F81002-5	16
26	PLATE AXIS CTD	509282-1	1 ¹
	CHAIN, SLPCTD3.6 ZINC-PLATED	099310	4
	CHAIN, SLPCTD5.4	099571	4
	CHAIN, CTC7.2	099572	4

7 CROSS TRANSFER DECK

Central Module

¹ Option

7.2 Central Module

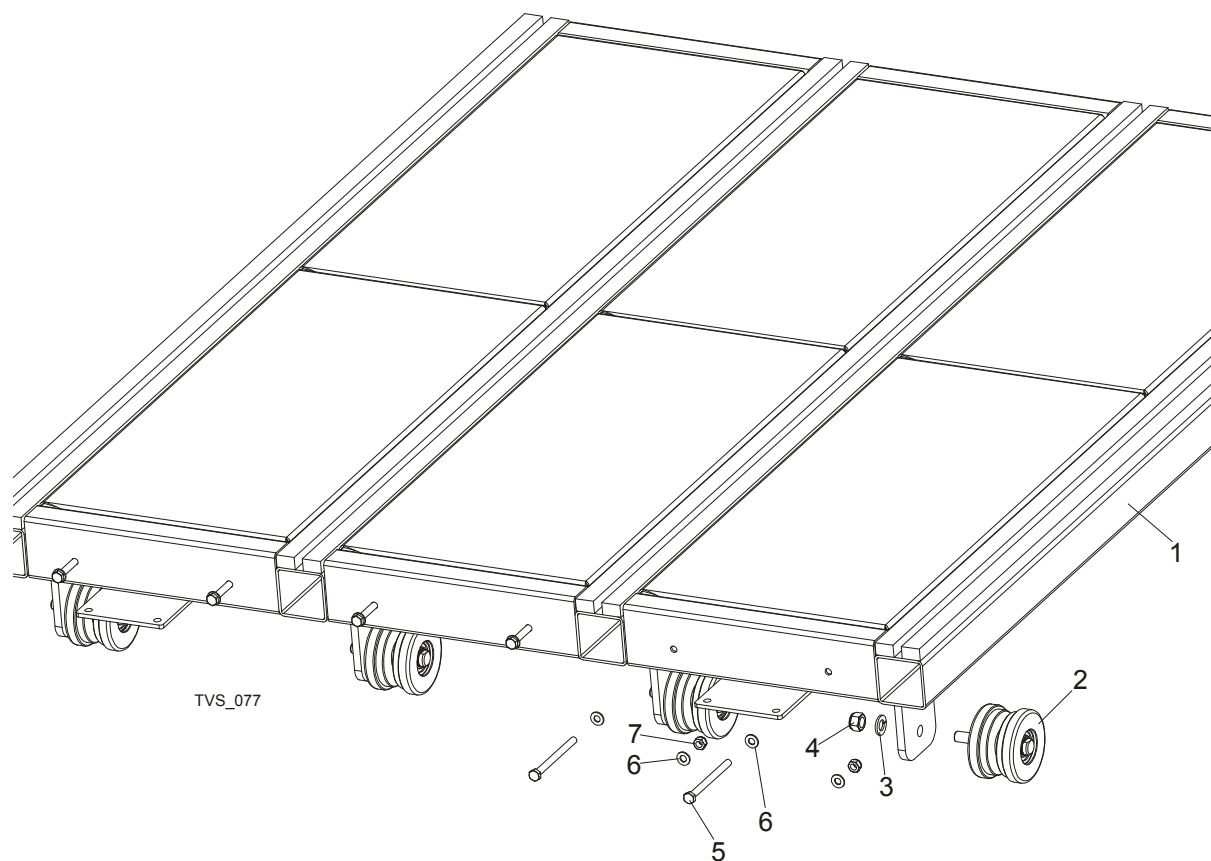

REF	DESCRIPTION (◆ Indicates Parts Available In Assemblies Only)	PART #	QTY.
	COMPLETE CENTRAL MODULE	099557	1/2 ¹
1	MODULE, CTD CENTRAL PAINTED	098125-1	1
2	WHEEL, CTD COMPLETE	098492	4
3	WASHER, 16.3 SPLIT LOCK ZINC	F81058-2	4
4	NUT, M16-8 HEX NYLON ZINC LOCK	F81036-2	4
5	BOLT, M10x125-8.8 HEX HEAD ZINC	F81003-18	6
6	WASHER, 10.5 FLAT ZINC	F81055-1	12
7	NUT, M10-8-B HEX NYLON ZINC LOCK	F81033-1	6

¹ Used on CTD5.4 - 1 piece and on CTD7.2 - 2 pieces.

7.3 Rear Module

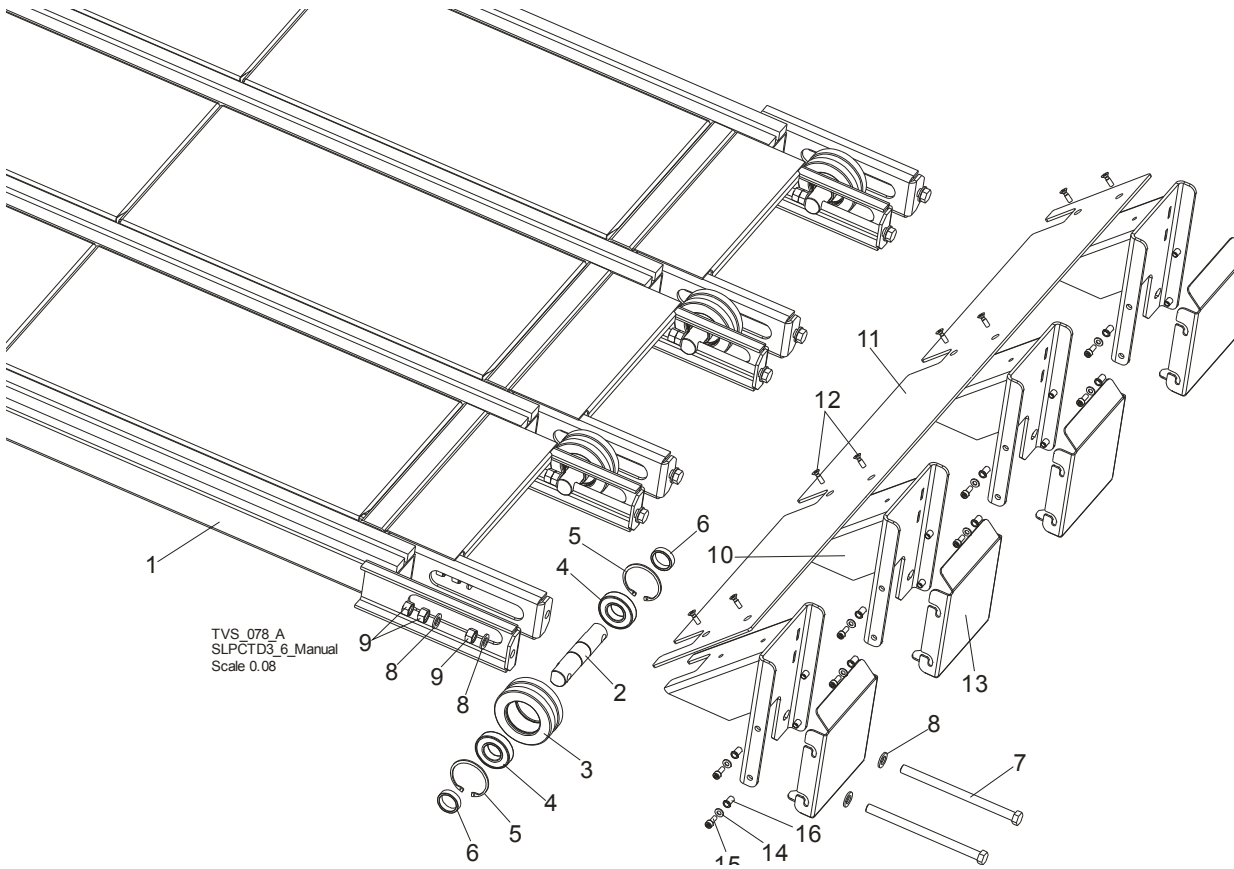

REF	DESCRIPTION (◆ Indicates Parts Available In Assemblies Only)	PART #	QTY.
	COMPLETE REAR MODULE	099558	1
1	FRAME WELDMENT, CTD REAR PTD	097900-1	1
	COMPLETE CHAIN TENSION WHEEL	097655	4
2	SHAFT, CHAIN TENSION WHEEL	096207-1	1
3	WHEEL, TVS CHAIN TENSION	096208-1	1
4	BEARING, 6207-2RS, C3, 35X72X17	014811	2
5	RING, W72 INSIDE RETAINING	F81090-4	2
6	BUSHING, FI 36x FI 44x22 SPACER ZINC	099959-1	8
7	BOLT, M16X240-8.8-A2 FULL THREAD	F81006-29	8
8	WASHER, 17 FLAT ZINC	F81058-1	24
9	NUT, M16-5.8 HEX ZINC	F81036-1	24
	BUMPER ASSEMBLY	099560-1	1
10	BRACKET, BUMPER MOUNTING	098223-1	4
11	PLATE, CTD BUMPER	098496-1	1
12	SCREW, M8X25 CROSS RECESSED COUNTERSUNK HEAD	F81002-51	8
13	PLATE BUMPER	512626-1	4
14	WASHER, 8.4 FLAT,ZINC	F81054-1	16
15	BOLT, M8 X 20-8.8 SOCKET HEAD	F81002-30	16
16	NUT, M8 1.0-2.5 FTR-Z FE/ZN5 RIVET	F81032-9	16

7.5 Leg Kits

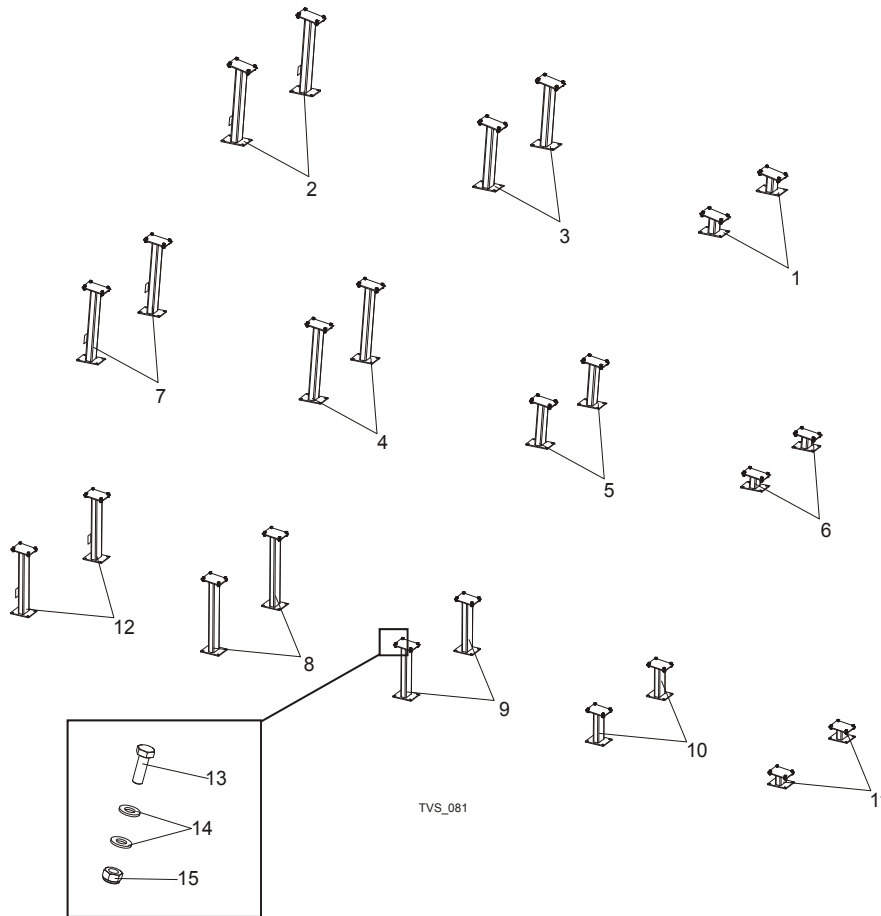

REF	DESCRIPTION (◆ Indicates Parts Available In Assemblies Only)	PART #	QTY.
	LEG KIT, CTD SHORT	099554	1
1	LEG, 7.6M REAR PTD	099279-1	2
2	LEG, FRONT PTD	099415-1	2
3	LEG, REAR PTD	099416-1	2
	LEG KIT, CTD MEDIUM	099568	1
4	LEG, CTD5.4 MIDDLE PTD (1)	099573-1	2
5	LEG, CTD5.4 MIDDLE PTD (2)	099574-1	2
6	LEG, CTD5.4 REAR PTD	099575-1	2
7	LEG, CTD5.4 FRONT PTD	099576-1	2
	LEG KIT, CTD LONG	099553	1
8	LEG, CTD7.2 MIDDLE PTD (1)	099277-1	2
9	LEG, CTD7.2 MIDDLE PTD (2)	099278-1	2
10	LEG, CTD7.2 MIDDLE PTD (3)	099562-1	2
11	LEG, CTD7.2 REAR PTD	099564-1	2
12	LEG, CTD7.2 FRONT PTD	099566-1	2
13	BOLT, M10x30-5.8 HEX HEAD FULL THREAD ZINC	F81003-2	24/32/40
14	WASHER, 10.5 FLAT ZINC	F81055-1	48/64/80
15	NUT, M10-8-B HEX NYLON ZINC LOCK	F81033-1	24/32/40

7.6 Slabs Table

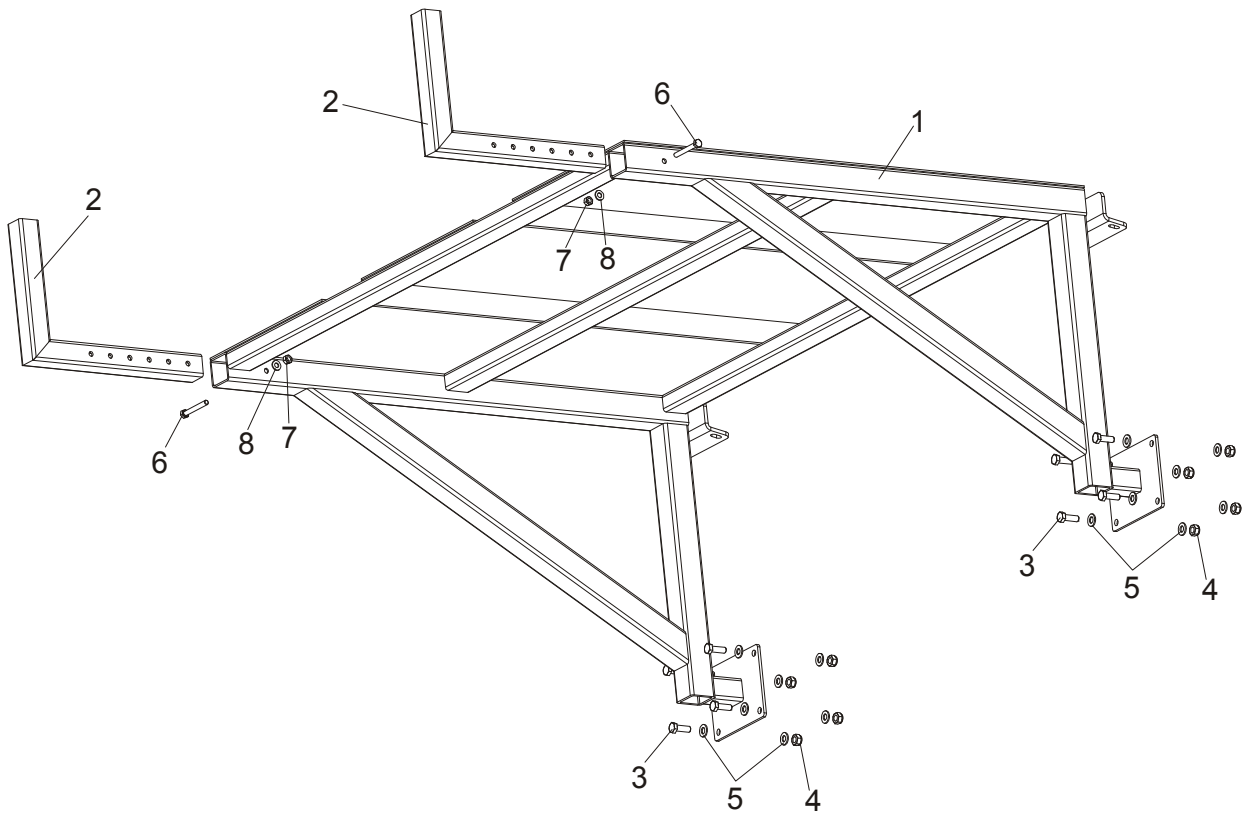

REF	DESCRIPTION (◆ Indicates Parts Available In Assemblies Only)	PART #	QTY.
1	TABLE, SLPCTD HIGH	100517-1	1
2	ARM, TABLE LOCK	100531-1	2
3	BOLT, M10X30-5.8 HEX HEAD FULL THREAD	F81003-2	8
4	NUT, M10-8-B NYLON HEX ZINC LOCK	F81033-1	16
5	WASHER, 10.5 FLAT ZINC	F81055-1	8
6	BOLT, M8X65 8.8 HEX HEAD ZINC	F81002-9	2
7	NUT, M8 HEXAGON, GRADE 5.8 FREE ZINC	F81032-1	2
8	WASHER, 8.4 FLAT ZINC	F81054-1	2

7.7 Decals

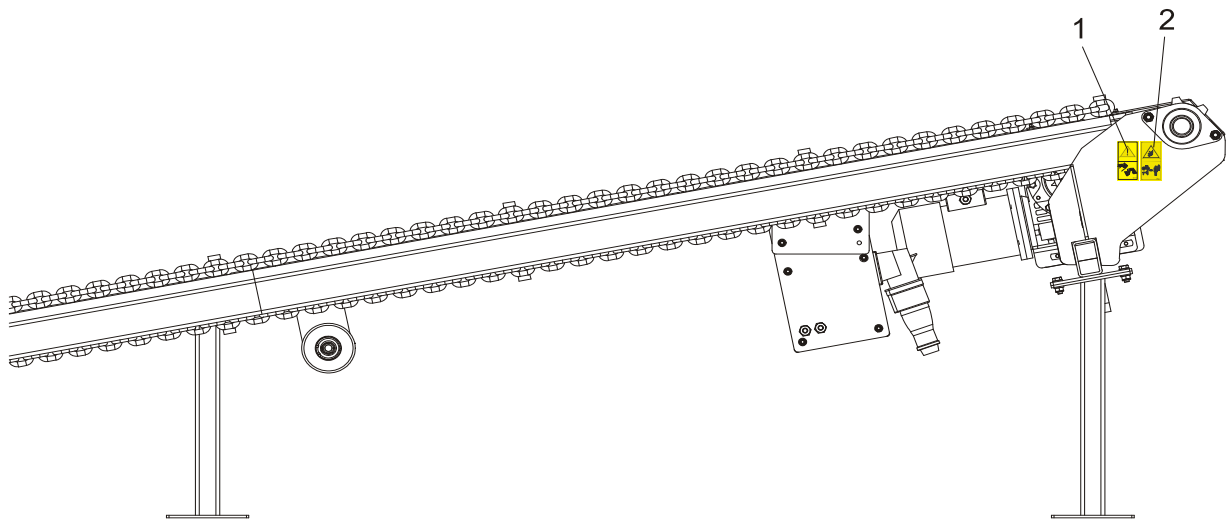
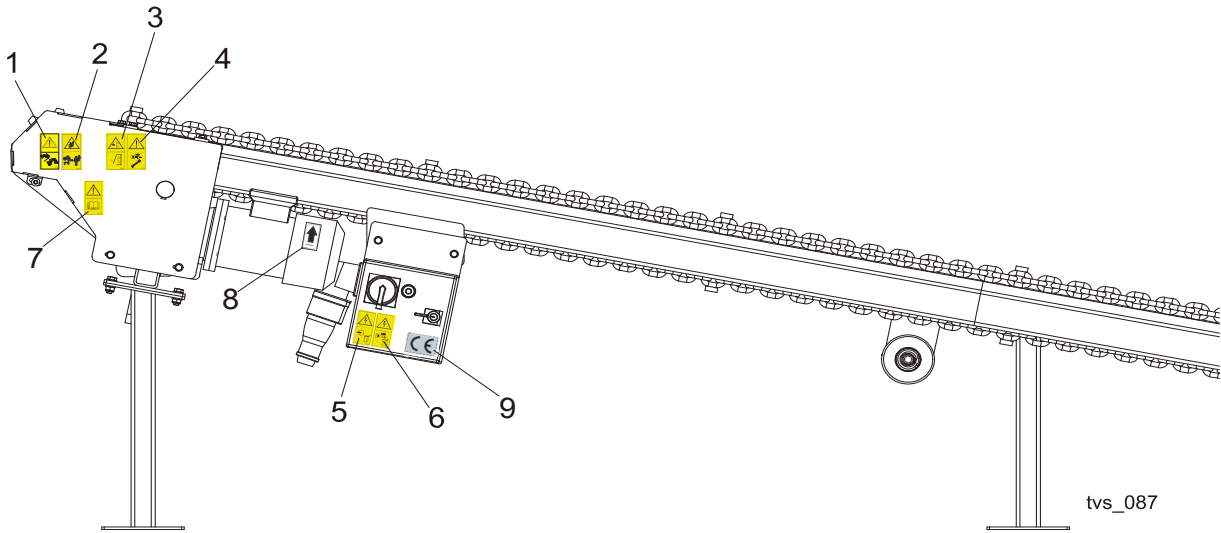

REF	DESCRIPTION (◆ Indicates Parts Available In Assemblies Only)	PART #	QTY.
	DECALS KIT, PICTOGRAMS, CROSS TRANSFER DECK	099835	1
1	Decal, Look out for the falling slabs (PICTOGRAM)	099780	2
2	Decal, Keep away warning (pictogram)	099221	2
3	Decal, Close all guards and covers before starting the machine	099220	1
4	Decal, Disconnect and lock out power supply before servicing (pictogram)	098177	1
5	Decal, High voltage inside the electric box (pictogram)	096316	1
6	Decal, Remove the plug before opening the box (pictogram)	096319	1
7	Decal, Read operator's manual (pictogram)	096317	1
8	Decal, 1400 RPM motor direction	S20097H	1
9	DECAL, CE - CERTIFIED SAWMILL	P85070	1