

**Wood-Mizer®**  
*from forest to final form*

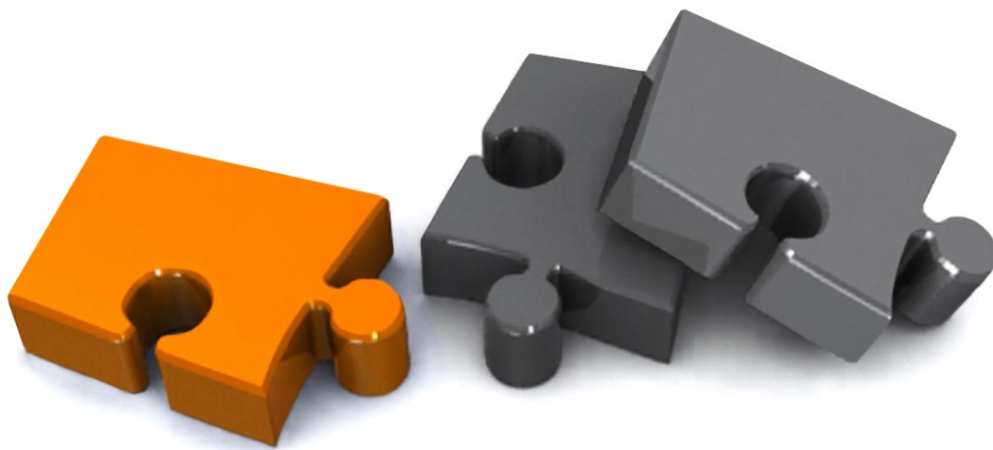

user **manual**

# Wood-Mizer<sup>®</sup> Sawmill

## Safety, Setup, Operation & Maintenance Manual

---

LT40L RAH

rev.B6.00

---



**Safety is our #1 concern!** Read and understand all safety information and instructions before operating, setting up or maintaining this machine.

*July 2001*

*Form #1002*

This manual is to replace or to be used with all previous information received on the Wood-Mizer®\* sawmill. All future mailings will be an addition to or a revision of individual sections of this manual as we obtain new information.

The information and instructions given in this manual do not amend or extend the limited warranties for the equipment given at the time of purchase.

### ***If You Need To Order Parts...***

From Europe call our European Headquarters and Manufacturing Facility in Kolo, Poland at **+48-63-2626000**. From the continental U.S., call our toll-free Parts hotline at **1-800-448-7881**. Please have the vehicle identification number and your customer number ready when you call. Wood-Mizer will accept these methods of payment:

- Visa, Mastercard, or Select Purchase
- COD
- Prepayment
- Net 15 (with approved credit)

Be aware that shipping and handling charges may apply. Handling charges are based on size and quantity of order. In most cases, items will ship on the day they are ordered. Second Day and Next Day shipping are available at additional cost.

### ***If You Need Service...***

From Europe call our European Headquarters and Manufacturing Facility in Kolo, Poland at **+48-63-2626000**. From the continental U.S., call us toll-free at **1-800-525-8100**. Ask to speak with a Customer Service Representative. Please have your vehicle identification number and your customer number ready when you call. The Service Representative can help you with questions about alignment of your mill, blade sharpening, or cutting a particular species of wood. He also can schedule you for a service call.

**Office Hours:** All times are Eastern Standard Time. Please remember that Indiana does not go on Daylight Savings Time in the summer.

<b>Country</b>	<b>Monday - Friday</b>	<b>Saturday</b>	<b>Sunday</b>
U.S., Indiana	8 a.m. to 5 p.m.	8 a.m. to 4 p.m.	Closed
Poland	8 a.m. to 4:30 p.m.	8 a.m. to 1 p.m.	Closed



**IMPORTANT!** Read the entire Operator's Manual before operating the sawmill. Take notice of all safety warnings throughout this manual and those posted on the machine. Keep this manual with this machine at all times, regardless of ownership.

\*Wood-Mizer® is a registered trademark of Wood-Mizer Products, Inc.

## Sawmill and Customer Identification

Each Wood-Mizer sawmill has a 17-digit Vehicle Identification Number (VIN). See the figure below for VIN locations. See the chart for VIN description.



**V.I.N. LOCATIONS.**

Company Identification Number 456=Wood-Mizer Indiana	Weight Class; A=Under 3,000 lbs B=3,001-4,000 lbs C=4,001-5000 lbs	Product No.; 1=LT15, 2=LT20, 4=LT40 Series, 7=LT70 Series	Length of the Trailer; 20=20 Ft., 24=24', 35=35'	Number of axles on the trailer	Check Digit Add all the number and divide by 11	Year of Manufacture; S=1995, T=1996, U=1997, V=1998, W=1999, X=2000	State of Manufacture N=Indiana, P=Poland	Month of Manufacture A=January, B=February, C=March, etc....	Revision Level	Sequence Number Ranging from 000-999	End of 17-Digit VIN	Revision Level (Repeated)	Two-Digit Minor Revision Level
<b>456</b>	<b>A</b>	<b>4</b>	<b>24</b>	<b>1</b>	<b>X</b>	<b>S</b>	<b>N</b>	<b>A</b>	<b>F9</b>	<b>017</b>		<b>F9</b>	<b>.01</b>

**V.I.N. DESCRIPTION**

Each sawmill is also identified with a model number which includes the base model and the engine/motor configuration. See the figure for a description of the model number.

**LT40**  
Basic Sawmill I.D.

**E25**  
Engine/Motor  
Configuration

**MODEL NUMBER DESCRIPTION.**

When you pick up your mill, you will receive a customer number. Both the VIN and your customer number expedite our service to you. Please write these numbers below so you have quick, easy access to them.

Customer No.	Model No.	V.I.N.	Revision

# Table of Contents

# Section-Page

## **SECTION 1 SAFETY & GENERAL INFORMATION 1-1**

1.1	Blade Handling.....	1-2
1.2	Sawmill Setup.....	1-3
1.3	Sawmill Operation.....	1-4
1.4	Maintenance .....	1-7
1.5	Belt Sizes .....	1-9
1.6	Blade Sizes .....	1-10
1.7	Cutting Capacity .....	1-11
1.8	Motor Specifications .....	1-12
1.9	Overall Dimensions .....	1-13
1.10	Chains .....	1-13
1.11	Hydraulic System .....	1-13
1.12	Components.....	1-14
1.13	LT40LR AH Hydraulic Schematic.....	1-15
1.14	LT40LR AH Hydraulic Components .....	1-15
1.15	LT40S/MR AH Hydraulic Hoses .....	1-17
1.16	Electrical Information.....	1-18

## **SECTION 2 SETUP & OPERATION 2-1**

2.1	Remote Operation.....	2-1
2.2	Preparing for Remote Operation .....	2-2
2.3	Remote Sawmill Operation .....	2-4
2.4	Stationary Sawmill Setup .....	2-5
2.5	Portable Sawmill Setup .....	2-7
2.6	Middle Track Cover .....	2-9
2.7	Replacing The Blade .....	2-10
2.8	Tensioning The Blade.....	2-11
2.9	Tracking The Blade .....	2-12
2.10	Starting The Motor .....	2-14
2.11	Hydraulic Control Operation.....	2-16
2.12	Loading, Turning, And Clamping Logs .....	2-19
2.13	Up/Down Operation .....	2-22
2.14	Blade Guide Arm Operation.....	2-24
2.15	Power Feed Operation.....	2-25
2.16	Instructions for PLC-AC Setworks Operation .....	2-27
2.17	Cutting The Log .....	2-32
2.18	Edging.....	2-34
2.19	Optional Cutting Procedure for Super Series Mills (Remote mills).....	2-35
2.20	Water Lube Operation .....	2-36
2.21	Preparing The Sawmill For Towing.....	2-38
2.22	Cold Weather Operation.....	2-43

# Table of Contents

# Section-Page

## SECTION 3 MAINTENANCE

3-1

3.1	Wear Life.....	3-1
3.2	Blade Guides .....	3-2
3.3	Sawdust Removal .....	3-2
3.4	Carriage Track, Wiper & Scrapers .....	3-3
3.5	Vertical Mast Rails .....	3-4
3.6	Drum Switches .....	3-4
3.7	Miscellaneous.....	3-5
3.8	Blade Tensioner.....	3-6
3.9	Blade Wheel Belts .....	3-8
3.10	Drive Belt Adjustment.....	3-9
3.11	Hydraulic System .....	3-10
3.12	Drive Bearing .....	3-11
3.13	Up/Down System.....	3-12
3.14	Power Feed .....	3-14
3.15	Clean The Cable Chain & Support Tray .....	3-16
3.16	Cable Chain Repair.....	3-16

## SECTION 4 TROUBLESHOOTING GUIDE

4-1

4.1	Sawing Problems.....	4-1
4.2	Electrical Problems.....	4-3
4.3	Power Feed Problems .....	4-5
4.4	Hydraulic Problems .....	4-7
4.5	Motor and Drive Pulleys Alignment .....	4-11
4.6	Power Feed Variable Speed Switch Test.....	4-12
4.7	Power Feed Preliminary Test .....	4-12
4.8	Power Feed Mechanical Test.....	4-12
4.9	Hydraulic Pressure Test.....	4-13

# Table of Contents

# Section-Page

## SECTION 5 SAWMILL ALIGNMENT

5-1

5.1	Pre-Alignment Procedures.....	5-1
5.2	Frame Setup.....	5-2
5.3	Blade Installation And Alignment.....	5-3
5.4	Saw Head Slide Pad Adjustment.....	5-6
5.5	Adjusting The Lower Track Rollers.....	5-8
5.6	Adjusting Bed Rails To The Blade.....	5-11
5.7	Blade Guide Arm Vertical Adjustment.....	5-14
5.8	Blade Guide Arm Horizontal Adjustment.....	5-16
5.9	Aligning the Blade Guides.....	5-18
5.10	Blade Deflection.....	5-19
5.11	Blade Guide Vertical Tilt Adjustment.....	5-20
5.12	Blade Guide Spacing.....	5-22
5.13	Horizontal Tilt Adjustment.....	5-23
5.14	Blade Guide Disc Adjustment.....	5-24
5.15	Horizontal Adjustment of Side Supports.....	5-26
5.16	Vertical Adjustment of Side Supports.....	5-27
5.17	Clamp Stop/Stop Bolt Adjustment.....	5-28
5.18	Saw Head Tilt.....	5-29
5.19	Blade Height Scale Adjustment.....	5-30
5.20	Board Return Bracket.....	5-31



## SECTION 1 SAFETY & GENERAL INFORMATION



This symbol calls your attention to instructions concerning your personal safety. Be sure to observe and follow these instructions. This symbol accompanies a signal word. The word **DANGER** indicates an imminently hazardous situation which, if not avoided, will result in death or serious injury. **WARNING** suggests a potentially hazardous situation which, if not avoided, could result in death or serious injury. **CAUTION** refers to potentially hazardous situations which, if not avoided, may result in minor or moderate injury to persons or equipment. Read all safety instructions before operating this equipment and observe all safety warnings!



Warning stripes are placed on areas where a single decal would be insufficient. To avoid serious injury, keep out of the path of any equipment marked with warning stripes.

Read and observe all safety instructions before operating this equipment! Also read any additional manufacturer's manuals and observe any applicable safety instructions including dangers, warnings, and cautions.

Always be sure that all safety decals are clean and readable. Replace all damaged safety decals to prevent personal injury or damage to the equipment. Contact your local distributor, or call your Customer Service Representative to order more decals.

**IMPORTANT!** It is always the owner's responsibility to comply with all applicable federal, state and local laws, rules and regulations regarding the ownership, operation and towing of your Wood-Mizer sawmill. All Wood-Mizer mill owners are encouraged to become thoroughly familiar with these applicable laws and comply with them fully while using or towing the mill.

Always properly dispose of all sawing by-products, including sawdust and other debris, coolant, oil, fuel, oil filters and fuel filters.

Safety instructions are listed in this section by the following operations:

- Blade Handling
- Sawmill Setup
- Sawmill Operation
- Sawmill Maintenance

## 1.1 Blade Handling



**DANGER!** Shut off the sawmill motor before changing the blade. Failure to do so will result in serious injury.



**WARNING!** Always wear gloves and eye protection when handling bandsaw blades. Changing blades is safest when done by one person! Keep all other persons away from area when coiling, carrying or changing a blade. Failure to do so may result in serious injury.



**WARNING!** Do not spin the blade wheels by hand. Spinning the blade wheels by hand may result in serious injury.

## 1.2 Sawmill Setup



**WARNING!** Chock the trailer wheels to prevent movement before unhitching it from the towing vehicle. Failure to do so may result in serious injury or death.

**WARNING!** Failure to put front outrigger down before moving cutting head from the rest position may result in serious injury.

**WARNING!** Securely fasten the feet of a stationary sawmill to the floor before operating the sawmill. Failure to do so may result in serious injury or death.

**WARNING!** Always make sure the trailer is supporting the sawmill frame when operating a sawmill with adjustable outriggers. Failure to do so may result in serious injury or death. The adjustable outriggers are intended to support the saw frame with assistance from the trailer.

**WARNING!** Do not set up the mill on ground with more than a 10 degree incline. If setup on an incline is necessary, put blocks under one side of the mill or dig out areas for outrigger legs to keep mill level. Setting up the mill on an incline could cause it to tip over, resulting in serious personal injury.



**CAUTION!** Changes in temperature could cause increased pressure in the blade tensioner and loss of fluid from the gauge. Release the blade tension when the mill is not in use to avoid damage to the tensioner.

### 1.3 Sawmill Operation



**DANGER!** Make sure all guards and covers are in place and secured before operating or towing the sawmill. Failure to do so may result in serious injury.

Be sure the blade housing and pulley covers are in place and secure. Use the safety retainer pin and cable to fasten blade housing covers.

**DANGER!** Always keep hands away from moving bandsaw blade. Failure to do so will result in serious injury.



**DANGER!** Stay clear of the area between the trailer axle and saw carriage. Failure to do so will result in serious injury.

**DANGER!** Keep all persons out of the path of moving equipment and logs when operating sawmill or loading and turning logs. Failure to do so will result in serious injury.

**DANGER!** Maintain a clean and clear path for all necessary movement around the mill and lumber stacking areas. Failure to do so will result in serious injury.

**DANGER!** Always be sure the blade is disengaged and all persons are out of the path of the blade before starting the engine or motor. Failure to do so will result in serious injury.

**DANGER!** Keep all persons out of the path of returning boards. Failure to do so will result in serious injury.



**WARNING!** Always wear eye, ear, respiration, and foot protection when operating the sawmill. Failure to do so may result in serious injury.

**WARNING!** Be sure the power feed switch is in the neutral position before turning the key switch to the (#1) or (#2) position. This prevents accidental carriage movement which may cause serious injury or death.



**WARNING!** Secure all loose clothing and jewelry before operating the sawmill. Failure to do so may result in serious injury or death.

**WARNING!** Always make sure log is clamped securely before sawing. Failure to do so may result in serious injury or death.

**WARNING!** Always leave loading arm halfway up while log is on sawmill bed. Failure to do so may result in serious injury or death.

**WARNING!** Use ONLY water with the water lube accessory. Never use flammable fuels or liquids. If these types of liquids are necessary to clean the blade, remove it and clean with a rag. Failure to do so may result in serious injury or death.



**CAUTION!** Be sure the pivot rails, turning arm, clamp, and toe boards are below bed level before loading a log onto the bed. Failure to do so may result in machine damage or cause misalignment.

**CAUTION!** Before loading a log, be sure the cutting head is moved far enough forward so the log does not hit it. Failure to do so may result in machine damage.



**CAUTION!** Be careful when manually lowering the log loader. Do not drop the loader onto the ground or perform any action which might break the velocity fuse valves on the loader cylinders. These valves control hydraulic flow and are necessary to prevent the loading arm from collapsing during use.

**CAUTION!** Do not try to force the saw head beyond its upper and lower travel limits. Damage to the up/down system may result.

**CAUTION!** Always make sure the up/down switch moves to the neutral or off position when released to ensure that the saw head stops moving. Failure to do so may result in machine damage.

**CAUTION!** If the weight of the sawmill exceeds 3,000 lbs (1361 Kg) for any reason, an auxiliary braking system (such as electric brakes) must be used. Failure to do so may result in severe machine damage.

**CAUTION!** Move the hydraulic clamp and turner to provide maximum ground clearance before towing. Failure to do so

may result in damage to the sawmill.

**CAUTION!** Be sure to stop the blade when returning the carriage. This will not only prevent the blade from being pulled off and ruined by a wood sliver, but also will increase the life of the blade.



**DANGER!** Any arbitrary repairs of the electric installation could result in serious injury or death.

**DANGER!** Any damaged electric parts, especially the wires supplying the power feed motors must be repaired by a qualified electrician.

**DANGER!** Any repairs done to the electric installation may be done by a qualified electrician with the power off.

**DANGER!** The electric connector must be equipped with a safety device to protect against shock.

**DANGER!** The electric connector must be installed by a qualified electrician.

**DANGER!** Do not operate the sawmill with an open electric box.

**DANGER!** In the event that water appears in the electric box further work on the sawmill may result in electric shock as well as damage to the power feed motor.

**DANGER!** The electric box door must always be closed, even when the sawmill is not in use.

**DANGER!** Always disconnect the power when the sawmill has been not in use for a long period.

**DANGER!** Any maintenance or repair must be done with the power off (the plug must be taken out of the outlet).

## 1.4 Maintenance



**WARNING!** Always secure the cutting head with a chain or a brace before adjusting the up/down chain. The cutting head may fall, causing severe injury or death.

**WARNING!** Always secure the cutting head with a chain or a brace before adjusting the mast pads. The cutting head may fall, causing severe injury or death.

**WARNING!** Always secure the cutting head with a chain or a brace before removing the up/down motor belt. The cutting head may fall, causing severe injury or death.

**WARNING!** Drum switch grease contains Petroleum Hydrocarbon Lubricant. Eye and skin irritant. If introduced into eyes, flush with water for at least 15 minutes. If film or irritation persists, seek medical attention. Wash skin with soap and water. If ingested, do not induce vomiting - contact a physician. KEEP OUT OF THE REACH OF CHILDREN.



**CAUTION!** Do not over-grease the blade guide bearings. Over-greasing will push the seals out of the bearings causing premature failure.

**CAUTION!** Reinstall the track wiper so that it lightly touches the track rail. If the wiper presses too firmly against the rail, it can cause the power feed to bind.

**CAUTION!** Never use grease on the mast rails as it will collect sawdust.

**CAUTION!** Do not use chain lube. It causes sawdust buildup in chain links.

**CAUTION!** Do not over-tension the up/down chain. Over-tensioning may lead to early failure of the gear reducer.

**CAUTION!** Do not overtighten the feed chain. Damage to the power feed motor may result.



**CAUTION!** Do not overtighten the contact set screws on the hydraulic valve assembly. Overtightening may cause the threads in the screw hole to strip.

**CAUTION!** Due to variations in the vertical mast, the pad spacing may vary throughout the travel of the saw head. Check the pad spacing at the top and bottom ends of the mast only. Pads adjusted too tight will cause premature up/down motor failure.

**CAUTION!** It is important that the lower stop bolts are properly adjusted to secure the carriage on the track rail. Failure to properly adjust the stop bolts can cause saw head damage, especially during mill transportation.

**CAUTION!** Pressure should not exceed 2000 psi. If it does, the amp draw will rise above the design maximum of 200 amps, and could cause battery and system problems. Pressure above 2000 p.s.i. may also damage the hydraulic hoses.

**CAUTION!** Failure to remove sawdust buildup from the battery box lid and/or track rail cover could result in damage to these parts when the saw head is lowered to its lowest position.



## 1.5 Belt Sizes

See Table 1-1. Belt sizes for the LT40 AH are shown.

Description	Belt Size	Wood-Mizer Part #
Blade Pulley Belts	B57 <sup>1</sup>	P04185
Power Feed Drive Belt	AX13X1000	086532
Up/Down Drive Belt	AX23	015257
Board Return Belt	3L190	015477
Motor Drive Belt EA20 & EA25 (50Hz)	3BX74	014249

**TABLE 1-1**

<sup>1</sup> To insure proper blade tracking, use Goodyear, Dayco Super II, or Browning belts only.

## 1.6 Blade Sizes

See Table 1-2. Wood-Mizer TRU•SHARP™ offers three types of blades to provide efficient sawing for all models of sawmills. The engine/motor size of your sawmill and the type of wood you saw should determine which blade you choose for optimum performance.

	Softwood	Medium Hardwood	Frozen Timber or Dense Hardwood
<b>5-15HP Gas</b>	.042 x 1 1/4" x 10°	.035 x 1 1/4" x 10°	.042 x 1 1/4" x 10°
<b>7.4-11kW (10-15HP) Electric 16-24HP Gas 30HP Diesel</b>	.045 x 1 1/2" x 10° or .045 x 1 1/4" x 10° <sup>1</sup>	.042 x 1 1/4" x 10°	.045 x 1 1/4" x 9° <sup>2</sup>
<b>15-18.5kW (20-25HP) Electric 40HP Diesel</b>	.045 x 1 1/2" x 10° or .045 x 1 1/4" x 10° <sup>1</sup>	.045 x 1 1/2" x 10° or .045 x 1 1/4" x 10° <sup>1</sup>	.045 x 1 1/4" x 9° <sup>2</sup>

TABLE 1-2

<sup>1</sup> Customer may choose preferred blade.

<sup>2</sup> TRU•SHARP™ 9° blades use a 9/29 profile (9° hook angle and 29° back angle) and are designed to cut frozen and/or extremely dense, hard-to-cut wood. Standard TRU•SHARP™ blades use a 10/30 profile.

See *The Blade Handbook* for blade hook angle, tooth height, and tooth set specifications.

## 1.7 Cutting Capacity

See Table 1-3. The log size capacities of the LT40 AH sawmills are listed below.

	Max. Diameter <sup>1</sup>	Max. Length <sup>1</sup>
LT40S AH	36" (91.5 cm)	16' 8" (5.1 m)
LT40M AH	36" (91.5 cm)	21' (6.4 m)
LT40S AH with Optional 6' Bed Extension <sup>2</sup>	36" (91.5 cm)	22' 8" (6.9 m)
LT40M AH with Optional 6' Bed Extension <sup>2</sup>	36" (91.5 cm)	27' (8.2 m)
LT40S AH with Optional 12' Bed Extension <sup>2</sup>	36" (91.5 cm)	28' 8" (8.7 m)
LT40M AH with Optional 12' Bed Extension <sup>2</sup>	36" (91.5 cm)	33' (10.1 m)
LT40S AH with Optional 24' Bed Extension <sup>2</sup>	36" (91.5 cm)	40' 8" (12.4 m)
LT40M AH with Optional 24' Bed Extension <sup>2</sup>	36" (91.5 cm)	45' (13.7 m)
LT40L AH	91,5 cm (36")	8,4m

**TABLE 1-3**

<sup>1</sup> Maximum log capacity for a basic mill is 4400 lbs. (1996 Kg).

<sup>2</sup> Logs over 4400 lbs. must be distributed so that neither the basic mill or extension is loaded beyond the 4400 lb. maximum weight rating. Loading logs heavier than 4400 lbs. (1996 Kg.) on a mill equipped with bed extension requires auxiliary log handling equipment.

See Table 1-4. The performance capacity of the LT40S/M/L AH sawmills is listed below. Peak cutting rates are measured in 12" (30 cm) wide red oak and represent the capability of the sawmill only. Rates based on using Tru-Sharp 1 1/2" x .045 blades.

Model	Blade speed	Cutting Rate
LT40S/M/L AH	30-35 m/s	18 m/min.

**TABLE 1-4**

## 1.8 Motor Specifications

See Table 1-5. The power options available for the LT40S/M AH sawmills are listed below.

Model	Manufacturer	Rated output	Current at 380V, 50Hz	Rated speed	Weight
<b>2Sg160M-2B HPS Motor, Tamel</b>	Tamel SA, Poland	15kW (20KM)	28,1 A	2930 RPM	117 Kg
<b>Sg 160L-2 HPS Motor, Indukta</b>	Indukta SA, Poland	18.5kW (25KM)	33,8 A	2930 RPM	135 Kg

TABLE 1-5

See Table 1-6. The other motors used in sawmills are listed below

Model	Manufacturer	Voltage	Rated output
<b>Power Feed Motor controlled by ALTIVAR (Super)</b>	Besel, Poland	3x380V	1,1 kW, 1380 RPM
<b>Up/Down Motor (2-Speed, Super only)</b>	Besel, Poland	3x380V	0,55/0,9 kW, 950/1400 RPM
<b>Hydraulic Pump Motor (Super only)</b>	Tamel, Poland	3x380V	4 kW
<b>Blade Guide Arm Motor</b>	Motor Products Owosso, USA	12V	17W, 60 RPM
<b>Up/Down-Remote controlled by PLC-Setworks and Altivar</b>	Besel, Poland	3x380V	0,75kW, 1380 RPM

TABLE 1-6

See Table 1-7. The noise level of the motors in Wood-Mizer sawmills.

	Idle	Engaged
<b>Sawmill with electric motor</b>	79 dB (A)	93 dB (A)

TABLE 1-7

# 1 Safety & General Information

## Overall Dimensions

### 1.9 Overall Dimensions

See Table 1-8. The overall dimensions of the Wood-Mizer LT40S/M AH sawmills are listed below.

Model	Length <sup>1</sup>	Width <sup>2</sup>	With (Operating Position with Loading Arms)	Height <sup>3</sup>	Weight	Weight w/Trailer
LT40S AH	21' 11" (6.7 m)	6' 6" (2 m)	8' 2" (2.5 m)	7' 8" (2.4 m)	3291 lbs. (1481 kg)	3716 lbs. (1672 kg)
LT40M AH	26' 2" (8 m)	6' 6" (2 m)	8' 2" (2.5 m)	7' 8" (2.4 m)	3491 lbs. (1571 kg)	3916 lbs. (1762 kg)
LT40MR AH	26' 2" (8 m)	6' 6" (2 m)	8' 2" (2.5 m)	7' 8" (2.4 m)	3491 lbs. (1571 kg)	3916 lbs. (1762 kg)
LT40L AH	10,8 m	2,3 m	2,5 m	2,3 m		2600 kg

TABLE 1-8

<sup>1</sup> Length from hitch to chain bracket.

<sup>2</sup> Width from fender to fender.

<sup>3</sup> Height from ground to mast. Placing head in maximum position will add to total height.

### 1.10 Chains

See Table 1-9. The load capacity of the chains is listed below.

	Load Capacity According to ISO Nr 08A-1
Power Feed Chain	1780N
Up/Down Chain	1780N

TABLE 1-9

### 1.11 Hydraulic System

See Table 1-10. The specifications of the hydraulic system are shown below.

Hydraulic Pump	HYDROIRMA
Pressure Rating	15MPa
Remote hyd. pump	HYDROIRMA

TABLE 1-10

1.12 Components

See Figure 1-1. The major components of the Wood-Mizer LT40LR AH are shown below.

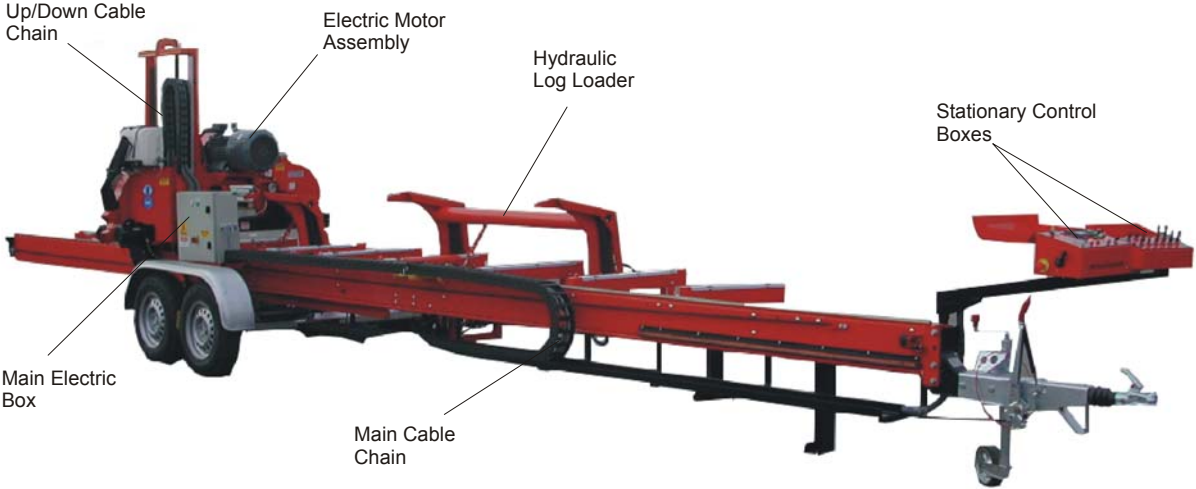

FIG. 1-1

# 1 Safety & General Information

## LT40LR AH Hydraulic Schematic

### 1.13 LT40LR AH Hydraulic Schematic

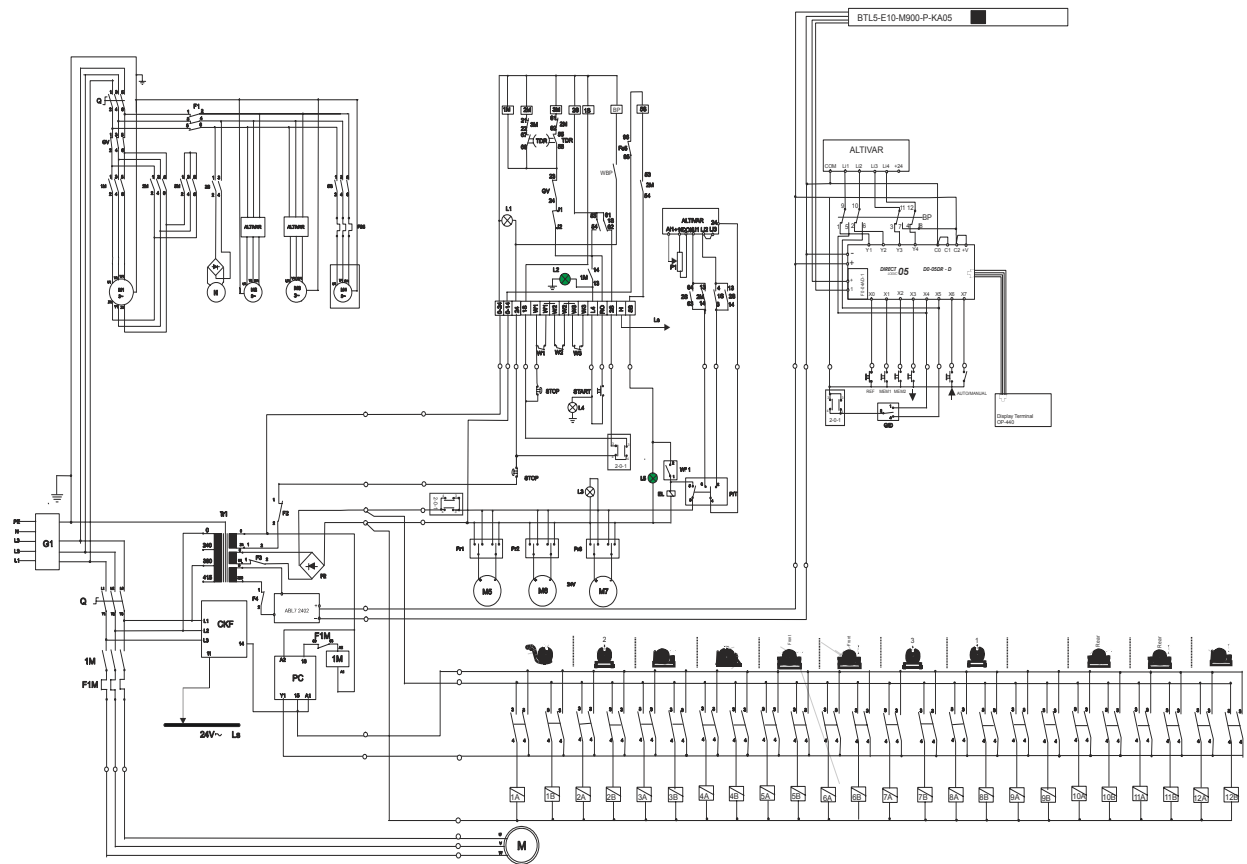

FIG. 1-2 HYDRAULIC SCHEMATIC.

### 1.14 LT40LR AH Hydraulic Components

ID	Mfg. Part No.	Manufacturer	Wood-Mizer Part #	Description
C1	015090	J-D Hydraulic	017275	Hyd. Cylinder, 3" Bore X 7 7/8" Stroke
C2	PMC-19410	Prince Mfg.	015053	Hyd. Cylinder, 1 1/2" Bore X 10" Stroke
C3	P12846	J-D Hydraulic	P12846	Hyd. Cylinder, 2 1/2" Bore X 8" Stroke
C4	P12845	J-D Hydraulic	P12845	Hyd. Cylinder, 2" Bore X 6" Stroke
C5, C6	014482	J-D Hydraulic	014482	Hyd. Cylinder, 1 1/2" Bore x 6" Stroke
C7, C8	P12847	J-D Hydraulic	P12847	Hyd. Cylinder, 3" Bore X 8" Stroke
M1, P1	---	Hydromar, Szamotuly	086789	Hydraulic Unit (Container + Hydraulic Pump + Motor), 14.5 l/min.

TABLE 1-11

<b>V1</b>	HDS11/6-6	Hydroirma.	015260	Valve, 6 section electrically activated
<b>V2, V3</b>	49004-700	Vonberg	015484	Sequence Valve
<b>V4, V5</b>	28000-502-2.5	Vonberg	015750	Valve, Hydraulic Velocity Fuse
<b>F1</b>	S28	Hyd. Filter Supply	P20301	Filter, Hydraulic Fluid Cartridge
<b>G1</b>	CF-1P-210A	Pressure Devices Inc.	P10052	Gauge, 3000 PSI Hydraulic

**TABLE 1-11**



# 1 Safety & General Information

## LT40S/MR AH Hydraulic Hoses

### 1.15 LT40S/MR AH Hydraulic Hoses

ID	Color Code	LENGTH "A"	Application	Wood-Mizer Part No.
H1	None	10"	3/8" Hydraulic Pump To Valve	087774
H2	Plain	27"	3/8" Log Turner Cylinder Base	014796
H3	Orange	21"	3/8" Log Turner Cylinder Top	087775
H4	Yellow	105"	1/4" Front Toe Board Top (LT40S)	087790
		127"	1/4" Front Toe Board Top (LT40M)	087776
H5	Gray	105"	1/4" Front Toe Board Base (LT40S)	087790
		127"	1/4" Front Toe Board Base (LT40M)	087776
H6	Pink	166"	3/8" Side Support Cylinder Base (LT40S)	087791
		188"	3/8" Side Support Cylinder Base (LT40M)	087777
H7	Plain	168"	3/8" Side Support Cylinder Top (LT40S)	087791
		188"	3/8" Side Support Cylinder Top (LT40M)	087777
H8	White	145"	3/8" Clamp Cylinder Top (LT40S)	087792
		157"	3/8" Clamp Cylinder Top (LT40M)	087778
H9	Dark Orange	129"	3/8" Clamp Cylinder Base (LT40S)	087793
		151"	3/8" Clamp Cylinder Base (LT40M)	087779
H10	Purple	204"	1/4" Rear Toe Board Top (LT40S)	087794
		226"	1/4" Rear Toe Board Top (LT40M)	087780
H11	Black	204"	1/4" Rear Toe Board Base (LT40S)	087794
		226"	1/4" Rear Toe Board Base (LT40M)	087780
H12	Green	62"	3/8" Loading Arm Branch Top	014797
H13	Yellow	63"	3/8" Loading Arm Branch Base	014798
H14	Blue	171"	3/8" Loading Arm Cylinder Top (LT40S)	087795
		193"	3/8" Loading Arm Cylinder Top (LT40M)	087781
H15	Red	171"	3/8" Loading Arm Cylinder Bottom (LT40S)	087795
		193"	3/8" Loading Arm Cylinder Bottom (LT40M)	087781
H16	Green	180"	1/4" Clamp Up (LT40S)	087796
		202"	1/4" Clamp Up (LT40M)	087789
H17	Yellow	180"	1/4" Clamp Down (LT40S)	087796
		202"	1/4" Clamp Down (LT40M)	087789

TABLE 1-12

1.16 Electrical Information

See Figure 1-3. The Hydraulic Pump Electrical Diagram is shown below.

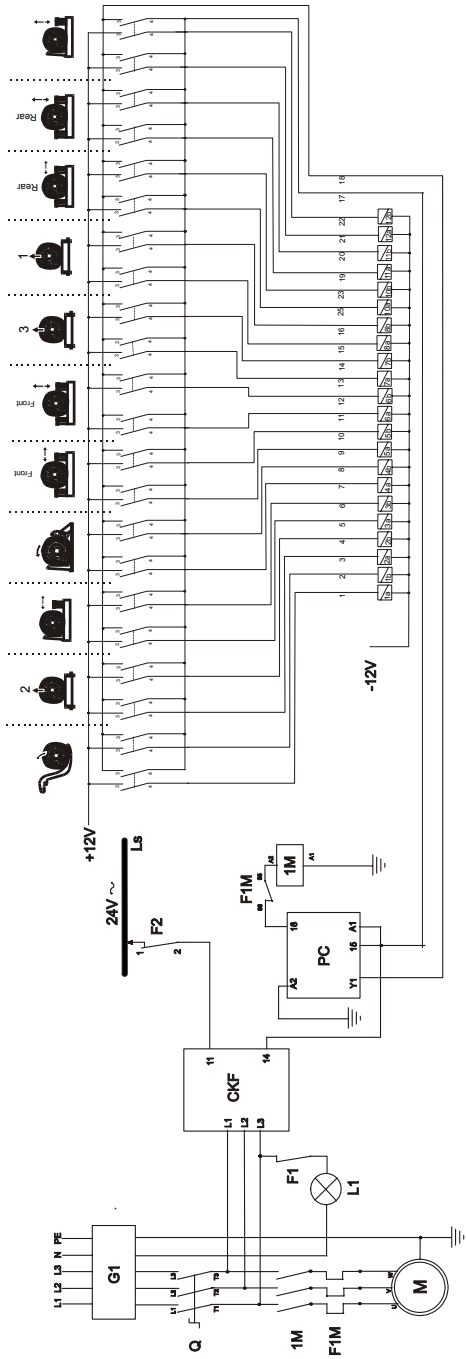

Ac01001

FIG. 1-3

# **1** Safety & General Information

## *Electrical Information*

---

### ***Description (See Figure above):***

- G1** - Socket 16A
- Q** - Main Switch
- 1M** - Pump Switch Contactor
- F1M** - Thermal Pump Motor Relay
- M** - Pump Motor
- L1** - Control Lamp (White - Power Turned On)
- F1** - Lamp Circuit Breaker
- CKF** - Phase Controller
- PC** - Time Relay
- W1** - Hydraulic Valve Microswitch
- F2** - Control Circuit Breaker
- Ls** - Power Supply Strip

---

## SECTION 2 SETUP & OPERATION

### 2.1 Remote Operation

The Remote Option provides remote operation for all sawmill functions from a single location at the front of the sawmill. The option includes all cables with traveling guide chain, a remote electrical power junction box, and a remote clutch mechanism with switch to engage the blade from the remote location.

The Remote Option also includes Wood-Mizer's Simple Networks system which allows automatic, incremental up/down movement of the cutting head.

## 2.2 Preparing for Remote Operation

Set up the sawmill as instructed in your sawmill operator's manual.

 **CAUTION!** Moving the saw carriage before removing the chain support may cause damage to the chain. Also, moving the saw carriage when the chain is frozen can damage the chain. [See Section 2.22](#) for recommended chain deicing procedure.

**See Figure 2-1.** Before moving the saw carriage, remove the cable chain support bracket.

1. Disengage the rubber strap holding the cable chain to the support bracket.
2. Loosen the handles and remove the support bracket from the sawmill track rail.
3. Place the support bracket on the storage bracket located on the sawmill frame between the first and second bed rails. Tighten the handles to secure the support bracket to the storage bracket and secure the rubber strap in the bracket hole.

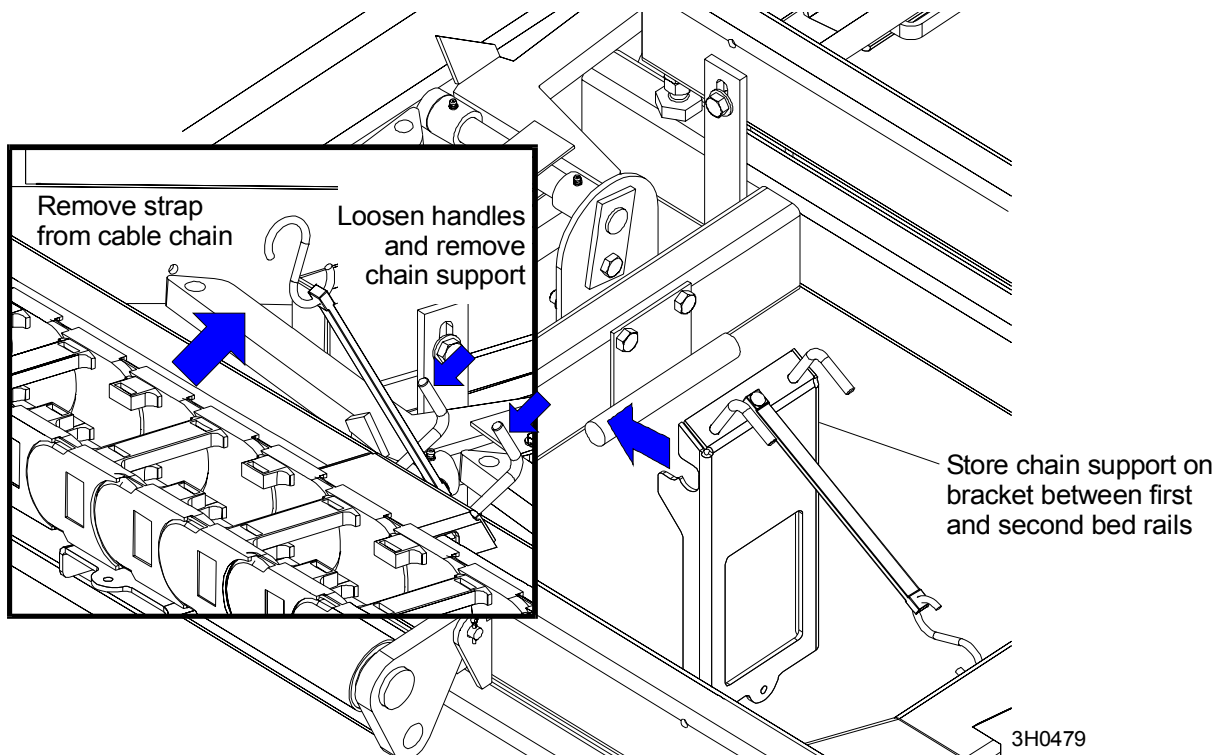

**FIG. 2-1**

Before operating the controls on the control box, you will need to pivot the control from its travel position to the operating position..

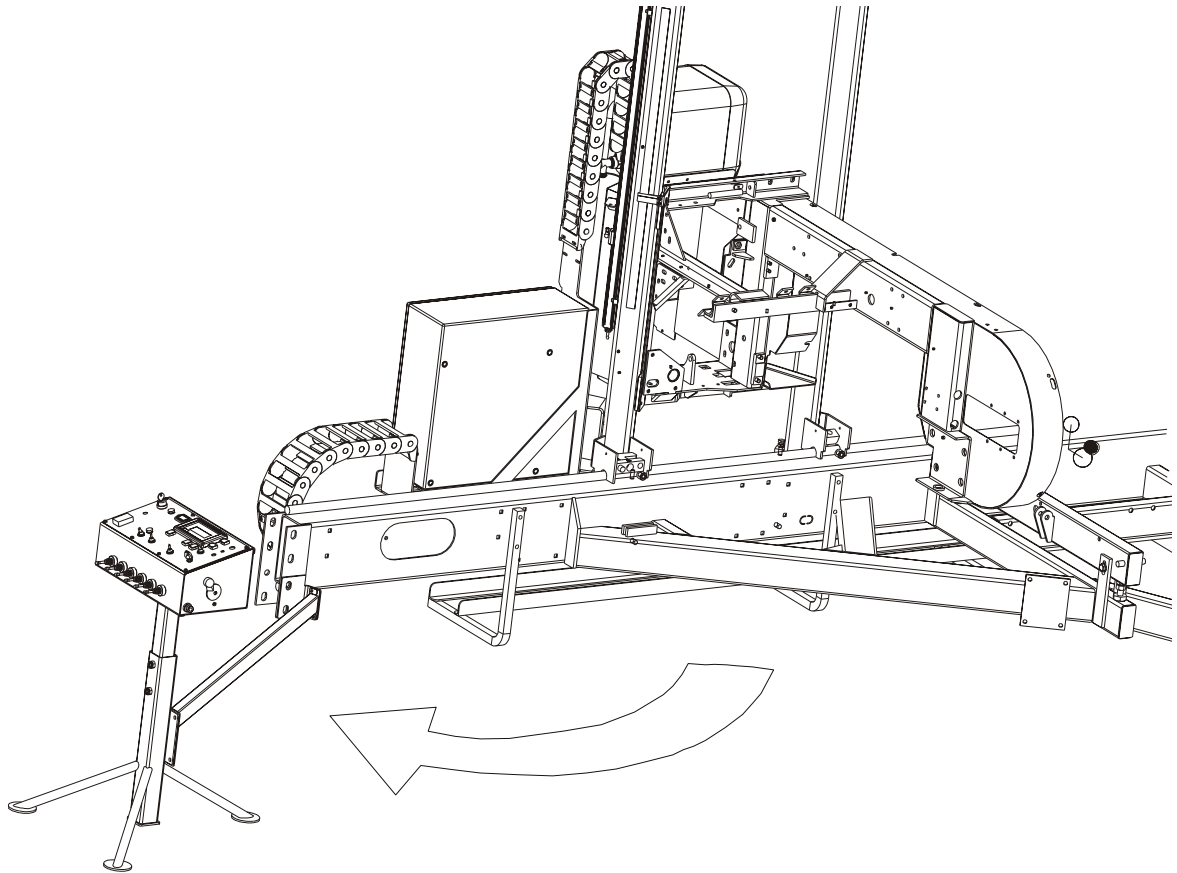

**FIG. 2-1**

Before start operating mount control panel in it's working position, using the special bracket.

## 2 Setup & Operation

### Remote Sawmill Operation

---

### 2.3 Remote Sawmill Operation



See Figure 2-2. All sawmill controls operate exactly as described in your sawmill operator's manual. Instead of pulling a handle to engage the blade, push the green button on the control panel.



**DANGER!** Keep all persons out of the path of moving equipment and logs when operating sawmill or loading and turning logs. Failure to do so will result in serious injury.

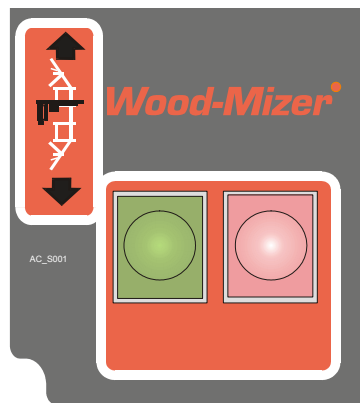

**FIG. 2-2**

To stop the blade and engage the electric motor, push the red button. It will stop the motor and the blade.

## 2.4 Stationary Sawmill Setup

See **Figure 2-3**. Set up the mill on firm footing and level by eye. Fasten the mill to the floor to prevent any creep after prolonged use. A concrete pad with 5/8" diameter anchor bolts is recommended. The concrete pad should be rated to support 6350 lbs./sq.ft. at each sawmill foot position.

**NOTE:** Make sure the unit is level before securing. It IS possible to twist the mill frame by jacking one foot higher than the others.

 **WARNING!** Securely fasten the feet of a stationary sawmill to the floor before operating the sawmill. Failure to do so may result in serious injury or death.

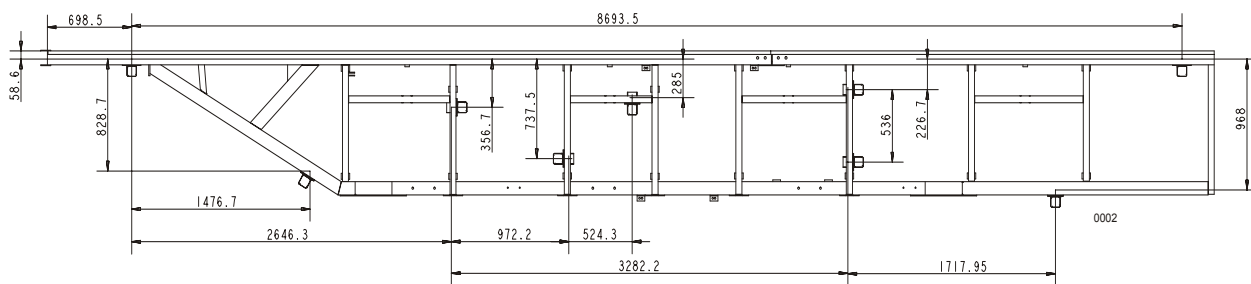



Stationary sawmill\*

\*all diameters in millimeters

**FIG. 2-3**

1. Unhook the carriage safety chain, located at the bottom of the vertical mast.

2.  Connect the power cord to the power cord connection box. Then turn power switch on (located on the front door of power cord box. Turn power switch on ( located on the main electric box ). Turn key switch located on the control panel to the position #2. Use the up/down switch on the control panel to raise the cutting head from the carriage rest pin. Remove the locking pin and swing the rest pin down below bed level.

3.  Use the carriage forward/reverse switch (left side of control box) to move the cutting head toward the front end of the mill. The hydraulic control levers become operational when the contacts at the bottom of the carriage touch the power strip on the frame tube. The hydraulic control levers will only work when the cutting head is close enough to the front end of the mill to touch the power strip.

4. Raise the two side supports that will prevent a log from falling off the side of the mill when



## 2 Setup & Operation

### Stationary Sawmill Setup

---

loaded.

5. Unbolt control panel from the frame and place on the left side of the frame.

 **CAUTION!** Make sure that electric boxes are closed before connecting the power cord to the power line connection box.

See Figure 2-4.

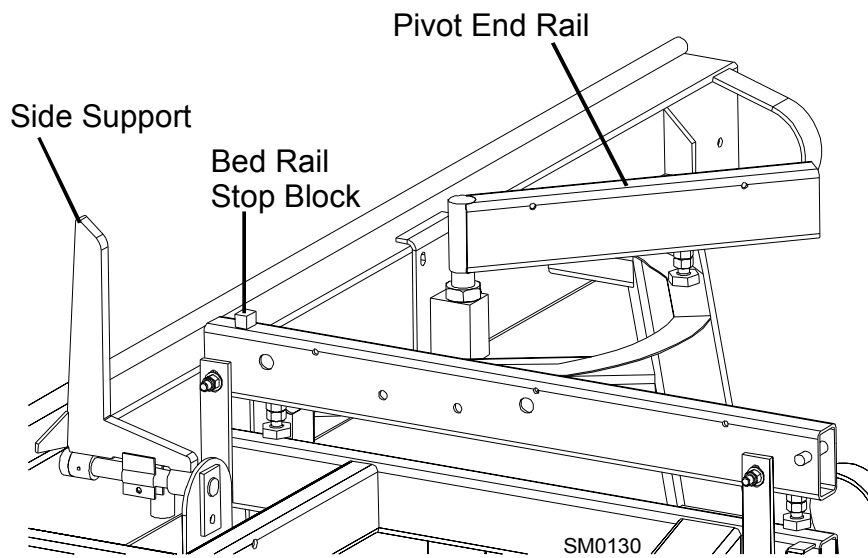

**FIG. 2-4**

## 2.5 Portable Sawmill Setup



**WARNING!** Do not set up the mill on ground with more than a 10 degree incline. If setup on an incline is necessary, put blocks under one side of the mill or dig out areas for outrigger legs to keep mill level. Setting up the mill on an incline could cause it to tip over, resulting in serious personal injury.

**WARNING!** Chock the trailer wheels to prevent movement before unhitching it from the towing vehicle. Failure to do so may result in serious injury or death.

**WARNING!** Always make sure the trailer is supporting the sawmill frame when operating a sawmill with adjustable outriggers. Failure to do so may result in serious injury or death. The adjustable outriggers are intended to support the saw frame with assistance from the trailer.

1. Unhitch the mill from the vehicle.
2. Lower and set the front three outriggers. Lift the weight from the locking pin using the jack handle. Pull the locking pin to release the outrigger and lower the outrigger as necessary. Secure with the locking pin.

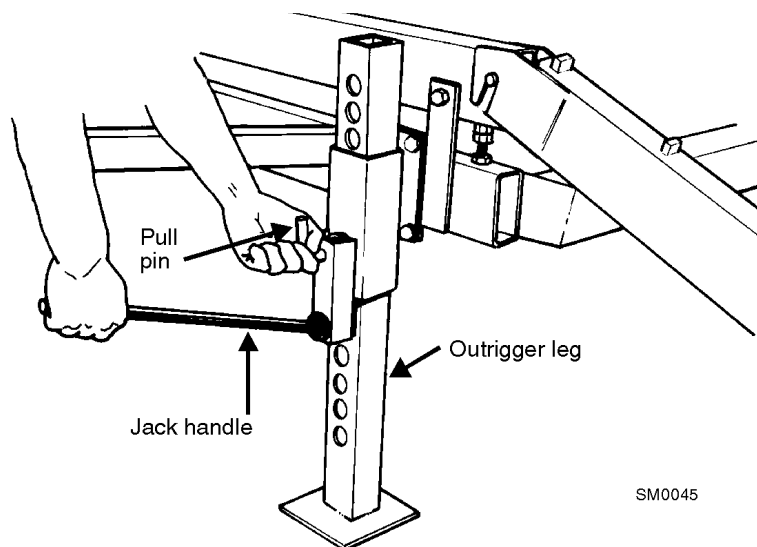

**FIG. 2-4. OUTRIGGER ADJUSTMENT.**

## 2 Setup & Operation

### Portable Sawmill Setup

3. Unhook the carriage safety chain, located at the bottom of the vertical mast.



4. Connect the power cord to the power cord connection box. Then turn power switch on (located on the front door of power cord box. Turn power switch on ( located on the main electric box ). Turn key switch located on the control panel to the position #2. Use the up/down switch on the control panel to raise the cutting head from the carriage rest pin. Remove the locking pin and swing the rest pin down below bed level.

5. Remove the fenders by lifting them out of the slots.



**CAUTION!** To prevent fender damage, remove fenders before operating sawmill or loading logs.



6. Move the cutting head toward the front end of the mill. Lower and set the remaining rear outriggers.

7. Level the sawmill by adjusting the outriggers to raise or lower each end of the sawmill. Adjust all outriggers evenly to avoid twisting the mill frame by jacking one outrigger higher than the others.

Raise the two side supports to prevent the log from falling off the side of the mill when loaded.

See Figure 2-5.

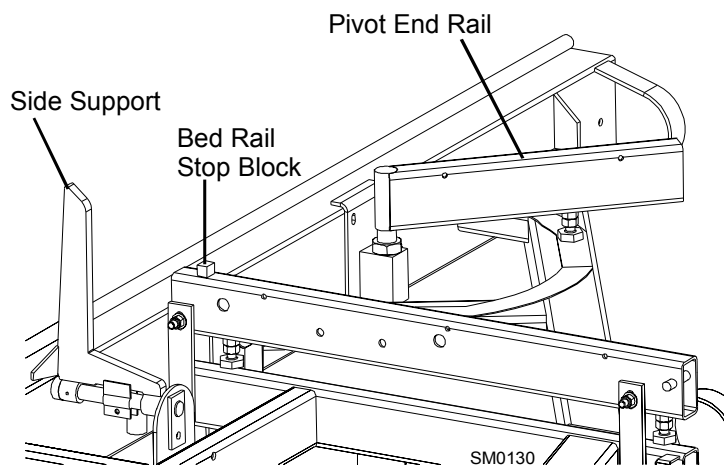

FIG. 2-5

## 2.6 Middle Track Cover

Before operating the sawmill do as follows:

1. Clean the upper and lower rails to remove any sawdust and rust preventives.
2. Unbolt and remove the middle track cover from its storage position.
3. Soak the felt wiper with Dexron III transmission fluid, 10W30 motor oil.
4. Install the middle track cover so it fits against the rail and secure with two thumb screws.

See Figure 2-6.

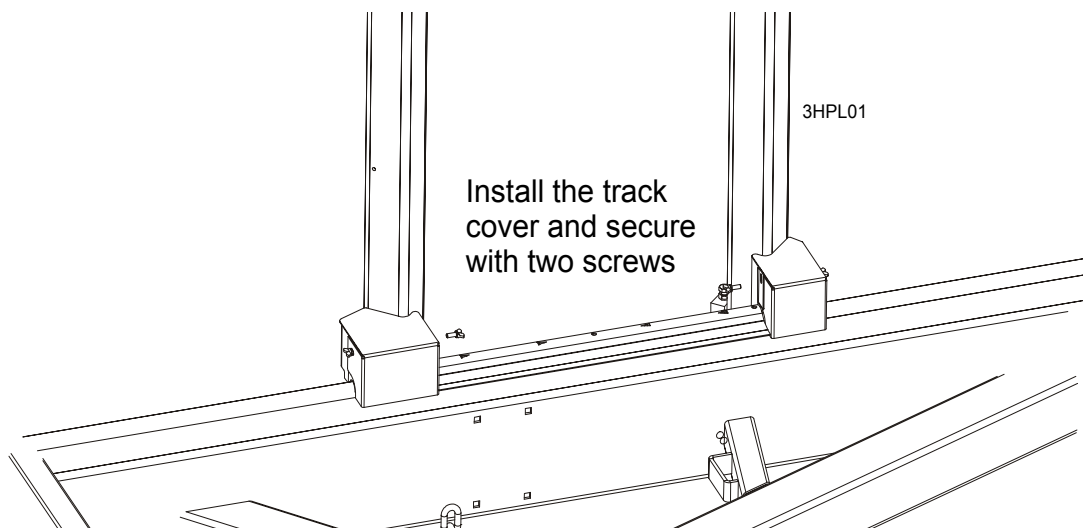

FIG. 2-6



**CAUTION!** Install the track cover so that it lightly touches the track rail. If the wiper presses too firmly against the rail, it can cause the power feed to bind.

## 2.7 Replacing The Blade



**DANGER!** Always disengage the blade and shut off the sawmill engine before changing the blade. Failure to do so will result in serious injury.



**WARNING!** Always wear gloves and eye protection when handling bandsaw blades. Changing blades is safest when done by one person! Keep all other persons away from area when coiling, carrying or changing a blade. Failure to do so may result in serious injury.

Remove the two main blade housing covers that cover the blade wheels. Lower the hinged middle blade housing cover. Turn the blade tension handle to release the blade tension until the wheel is pulled in and the blade is lying loose in the blade housing. Lift the blade out of the blade housing.

When installing a blade, make sure the teeth are pointing the correct direction. The teeth should be pointing toward the operator side of the mill when you are looking at the blade below the blade guides. Install the blade so it is lying around the wheels.

Position 1 1/4" wide blades on the wheels so the gullet is 1/8" (3.0 mm) out from the edge of the wheel. Position 1 1/2" wide blades on the wheels so the gullet is 3/16" (4.5 mm) out from the edge of the wheel.

Close the middle blade housing cover



**CAUTION!** When installing the left and right blade housing cover be careful not to damage the safety key switches (the key located on the cover must enter the safety switch slot).

Next, turn the tension handle until the blade is tensioned correctly.

### 2.8 Tensioning The Blade

See Figure 2-7. Tension the blade by turning the hydraulic tensioning handle clockwise until the tension gauge indicates the recommended tension.

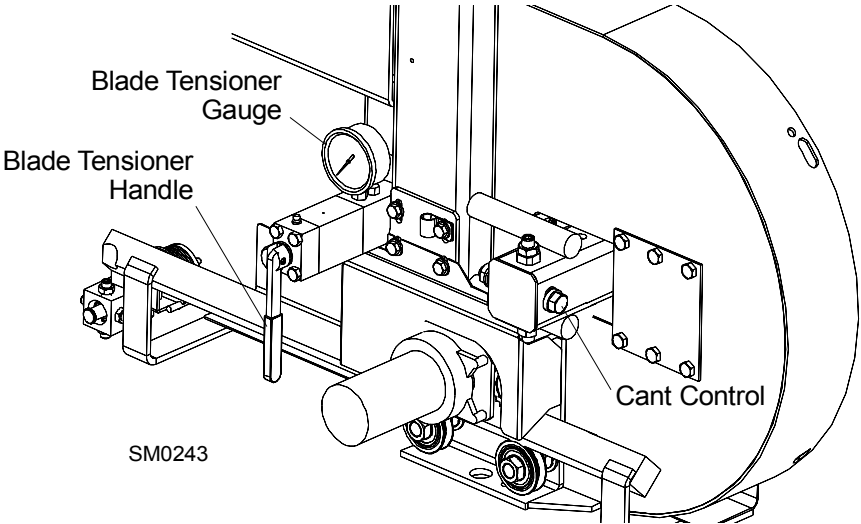

FIG. 2-7

See Table 2-1. The recommended tension for different blades is shown below.

Blade Type	Acceptable Range	Ideal Tension
.035" x 7/8" x 1 1/4"	1800 - 2100 psi	2000 psi
.042" x 7/8" x 1 1/4"	2100 - 2400 psi	2300 psi
.045" x 7/8" x 1 1/2"	2100 - 2400 psi	2300 psi

TABLE 2-1

The tension gauge should be checked occasionally when adjusting the cant control or while cutting. Ambient temperature changes will cause tension to change. Adjust the tension handle as necessary to maintain the recommended tension level.



**CAUTION!** Changes in temperature could cause increased pressure in the blade tensioner and loss of fluid from the gauge. Release the blade tension when the mill is not in use to avoid damage to the tensioner.

## 2.9 Tracking The Blade

1. Place the blade on blade guide wheels.
2. Tension the blade.
3. Turn the key switch to pos. #2.
4. Manually spin idle pulley

**See Figure 2-8.** Position 1 1/4" wide blades so the gullet is 1/8" (3.0 mm) out from the edge of the blade wheel ( $\pm 1/16$  [1.5 mm]). Position 1 1/2" blades so the gullet is 3/16" (4.5 mm) out from the edge of the blade wheel ( $\pm 1/16$  [1.5 mm]).

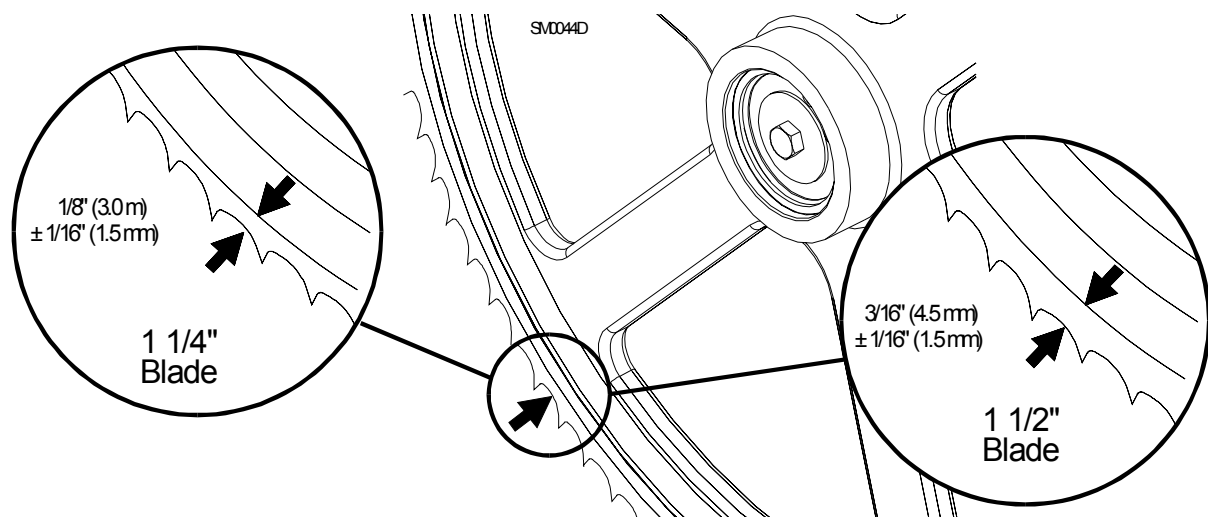

**FIG. 2-8**

5. To adjust where the blade travels on the blade wheels, use the cant control shown in **Figure 2-7**.

If the blade is too far out, back the blade onto the wheel by turning the cant control counterclockwise. If the blade is too far in, turn the cant control clockwise until the gullet of the blade is the correct distance from the front edge of the wheel.

6. Retension the blade to the recommended tension to compensate for any adjustments you have made in the cant control.
7. Install the blade housing covers.



**DANGER!** Make sure all guards and covers are in place and secured before operating or towing the sawmill. Failure to do so may result in serious injury. Be sure the blade housing and pulley covers are in place and secure. Use the safety retainer pin and cable to fasten blade housing covers.

**IMPORTANT!** After aligning the blade on the wheels, always double-check the blade guide spacing and location. (See Section 5 for more information.)



#### 2.10 Starting The Motor

See the appropriate manual supplied with your specific motor configuration for starting and operating instructions.



**DANGER!** Make sure all guards and covers are in place and secured before operating or towing the sawmill. Failure to do so may result in serious injury. Be sure the blade housing and pulley covers are in place and secure. Use the safety retainer pin and cable to fasten blade housing covers.

**DANGER!** Check the sawmill wiring every year. Make sure all electrical installation, service and/or maintenance work is performed by a qualified electrician.

**DANGER!** Do not operate or leave the sawmill with the electrical boxes open. Failure to do so may cause serious injury or death.



**WARNING!** Always wear eye, ear, respiration, and foot protection when operating the sawmill. Failure to do so may result in serious injury.

**WARNING!** Be sure the power feed switch is in the neutral position before turning the key switch to the (#1) or (#2) position. This prevents accidental carriage movement, which may cause serious injury or death.

**WARNING!** Hazardous voltage inside the electric box is dangerous. Turn the main switch to the OFF ("0") position and lock out power supply before opening the box door!

**WARNING!** The door of the electric box can be opened only when the main switch is in the "0" position. The door is closed when the switch is in the "1" position. Serious damage to the box may result while opening the door when the main switch is in the "1" position.

At least once a year the electric wires should be checked for isolation and hazardous voltage by a qualified person.

Keep the electrical starter box clean. Remove any dust or wood chips from the box from time to time. Make sure the electric box door is closed before operating the sawmill.

**WARNING!** Hazardous voltage inside the electric box and inside the motor can cause shock, burns, and death. Turn the main switch to the OFF ("0") position and lock out power supply before opening the box door!

The time-delay relay in the electrical starter box attached to the hydraulic box should be set between 4 and 5 seconds.

After installation, test the sawmill for proper motor rotation.

If rotation is incorrect, turn the motor off pushing the STOP button located on the control box. Turn the main switch on the starter box to the OFF ("0") position. Disconnect the power cord on the left side of the starter box.

Use the screwdriver to turn the phase converter switch to the left or to the right to change the motor rotation.

If the phase is improper hydraulic pump motor will not be working

## 2.11 Hydraulic Control Operation

The hydraulic control levers become operational when the main switch located on the main electric box is in the “on” position the contacts at the bottom of the carriage touch the power strip on the frame tube. The hydraulic control levers will only work when the cutting head is close enough to the front end of the mill to touch the power strip.

 **DANGER!** The main electric box must be powered with a connector equipped with a secure circuit (current change switch).

The hydraulic electric motor turns on automatically by raising or lowering of the control levers. After putting the control levers in neutral the hydraulic electric motor works still by 5 seconds. It prevents the hydraulic motor pumps from frequently starting and overheating.

After taking all of the above steps, if the hydraulic system still does not work properly you must make sure that voltage indicator is lit up. Next you must check to see whether the safety switch on the left side of the operator box is turned on. Motor rotation may also need to be checked (hydraulic pumps can only run in one direction). If blade moves in improper direction, it means that the hydraulic motor doesn't work. You can adjust the motor rotation direction by removing the plug from outlet located on the left side of the power cord connection box. Place the screwdriver in the outlet ( where the power pins are ), rotate the screw by 180 degrees and connect the power cord again.

**See Figure 2-9.** Hydraulic units have six control levers to load, clamp, turn and level logs

( located on the operated box ).

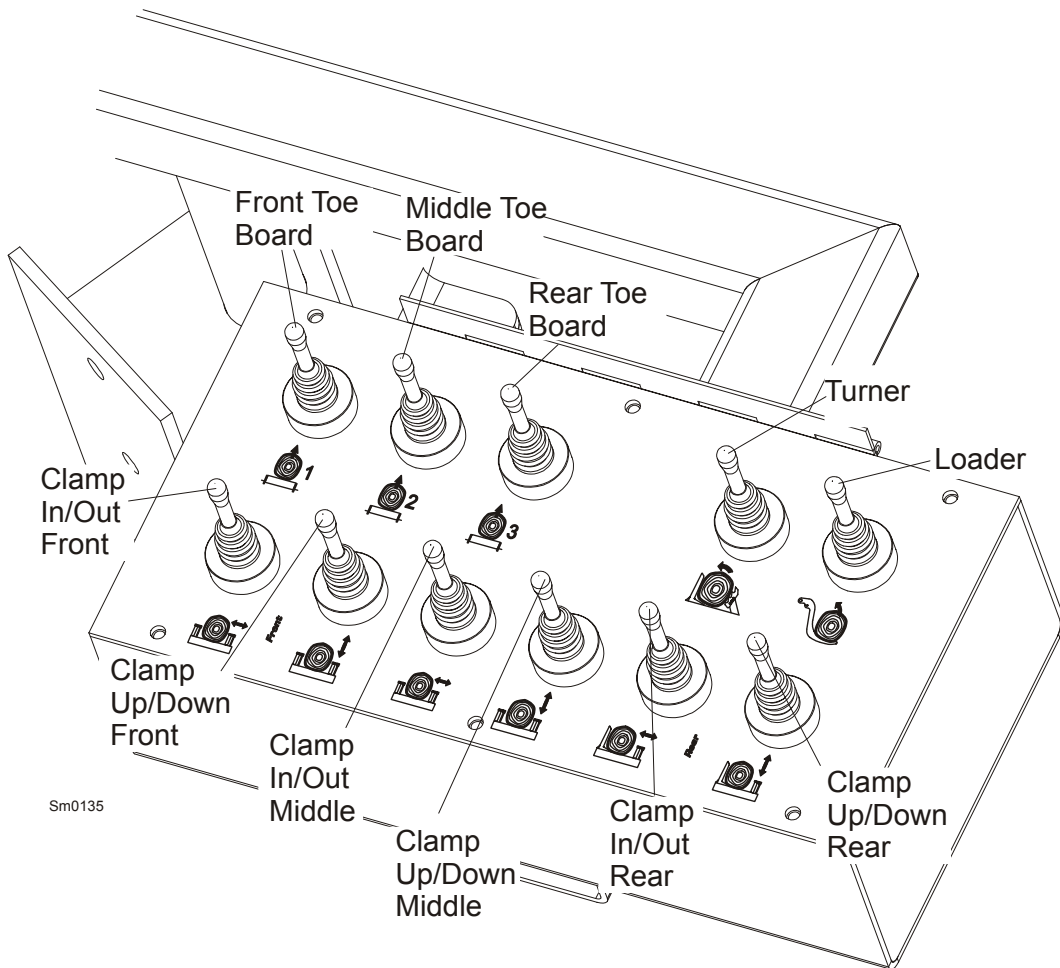

FIG. 2-9

**⚠ DANGER!** Keep all persons out of the path of moving equipment and logs when operating sawmill or loading and turning logs. Failure to do so will result in serious injury.

## 2 Setup & Operation

### Hydraulic Control Operation

---

1. Move the clamp out and down so it will not get in the way of logs being loaded onto the bed.



Lower the clamp in/out lever to move the clamp out toward the loading side of the sawmill.



Lower the clamp up/down lever to lower the clamp below bed level.

2. Raise the log loader lever to extend the legs of the log loader out as far as they will go.



3. The chain securing the log loading arm to the log turner arm will be tight. Raise the log turner lever to raise the turner arm until there is slack in the chain.



4. Unchain the loading arm from the turner arm.

5. Lower the turner lever to completely lower the turner arm. Notice that after the turner arm is all the way down, the side support braces will begin to lower. Release the turner lever after the turner arm is lowered, but before the side supports begin to lower. This stops the log being loaded from damaging the turner and/or falling off the side of the sawmill.



6. When raising the turner lever, the side supports rise first. After reaching a fully vertical position, the turner arm will engage and start to rise.

7. Manually lower the log loader so the legs rest on the ground.



**CAUTION!** Be careful when manually lowering the log loader. Do not drop the loader onto the ground or perform any action which might break the velocity fuse valves on the loader cylinders. These valves control hydraulic flow and are necessary to prevent the loading arm from collapsing during use.

8. Lower the loader lever to lower the loading arm as far as it will go. Logs must be rolled onto the loading arm one at a time for loading onto the bed of the mill.



9. The front and rear toe boards should be below bed level. Once a tapered log has been loaded, the front or rear end of the log may be lifted to parallel the heart of the log to the path of the blade.



The front toe board is raised by lifting the front toe board lever up. The rear toe board is raised by lifting the rear toe board lever up. Once a flat has been made and the log is ready to be turned, push the appropriate toe board lever down to lower either toe board until it falls below the level of the bed.

## 2.12 Loading, Turning, And Clamping Logs



**CAUTION!** Be sure the pivot rails, turning arm, clamp, and toe boards are below bed level before loading a log onto the bed. Failure to do so may result in machine damage or cause misalignment.

### To Load Logs

1. Move a log up to the loading arm. Use cant hooks or loading equipment to move the logs to the foot of the loading arms.
2. Roll the log onto the loader so that it is approximately centered with the sawmill bed. The log turner will operate much easier if the log is centered on the sawmill bed.
3. Raise the loader lever to raise the log onto the sawmill bed. Simply let the loader rise until the log rolls onto the mill bed.



4. Lower the loading arm. Leave the loading arm about halfway up while squaring the log. This will stop the log from rolling off the side of the mill.



**WARNING!** Always leave loading arm halfway up while log is on sawmill bed. Failure to do so may result in serious injury or death.

**NOTE:** Logs also may be loaded onto the mill with a tractor or other equipment specifically designed for that purpose.

5. Raise the clamp up to prevent the log from rolling of the bed.
6. Raise the clamp up/down lever.



**To Turn Logs**

1. Raise the turner lever to engage the log turner arm. Let the arm rise until it touches the log and starts to turn it.



2. Spin the log against the side supports until it is turned the way you want it for the first cut. If you want to turn the log more, do the following steps.

3. Engage the clamp by raising the clamp in/out lever. Clamp the log against the side supports.



4. Lower the turner lever to lower the turner arm below the log.



5. Raise the turner arm to get a new bite on the log.
6. Disengage the clamp.
7. The log can be turned now. Repeat steps 4 through 7 until the log is turned as desired.

**To Turn Logs (Optional Procedure For Hydraulic Mills Except Only)**

If you are turning a small cant on a Super Series mill, you may opt to use the clamp to turn the cant.

1. Lower the clamp up/down lever to lower the clamp below bed level.
2. Raise the clamp in/out lever to move the clamp in, beneath the edge of the cant.
3. Raise the clamp up/down lever to raise the clamp and flip the cant.

### To Clamp Logs

1. Raise the clamp in/out lever and clamp the log against the side supports.



2. Lower the turner lever until the turner arm falls below the bed.



3. When the turner arm is lowered all the way, the side supports will begin to lower. Back the clamp off slightly, and let the side supports come down until they are positioned below the level of your first few cuts.

### To Level A Tapered Log

Use the toe board lever(s) to raise either end of a tapered log, if desired.



Raise the appropriate lever to raise the front or rear toe board until the heart of the log measures the same distance from the bed rails at each end of the log.



### 2.13 Up/Down Operation

#### Setwork manual and bypass mode.

1. Install a blade, if needed, and check for correct blade tension. ([See Section 2.8](#)).
2. Set the cutting head to the desired height. (Which is shown on the PLC Network display, as well you can read it on the auxiliary blade height scale.)

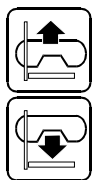

**See Figure 2-10.** The up/down switch is located on the far right side of the control panel. Push the switch up to raise the cutting head; push the switch down to lower the cutting head. Hold the switch in position until the cutting head reaches the desired height, then release.

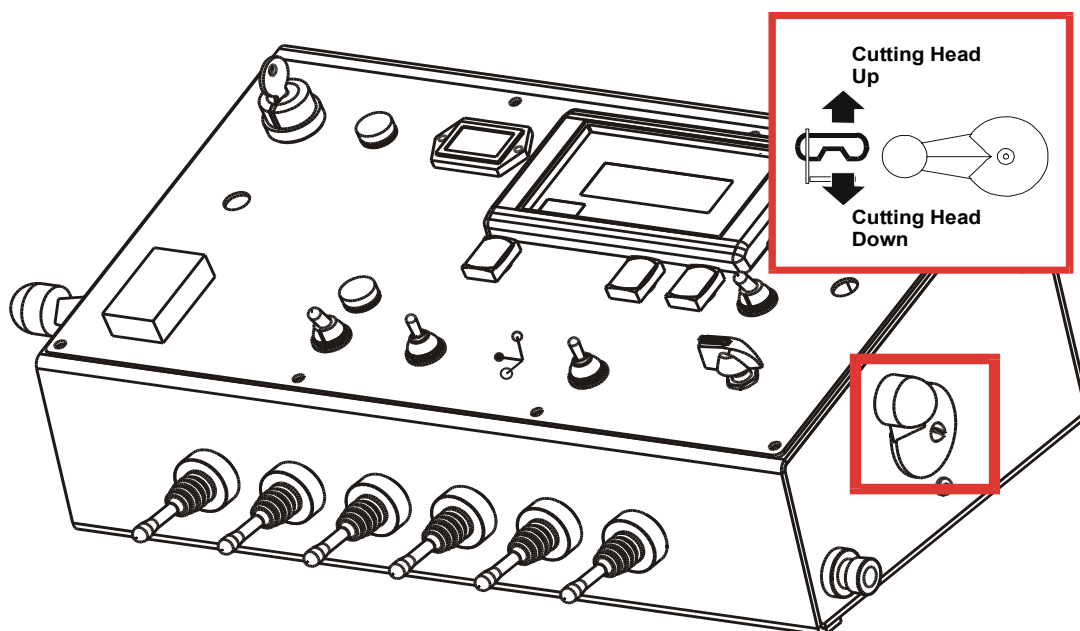

FIG. 2-10

The up/down switch is designed to return to the neutral or "off" position when released. If the switch remains engaged, manually move the switch to the neutral or "off" position. Repair the up/down drum switch ([See Section 4.2](#)).



**CAUTION!** Always make sure the up/down switch moves to the neutral or "off" position when released to ensure that the saw head stops moving. Failure to do so may result in machine damage.

**CAUTION!** DO NOT try to force the carriage above the 35" (88 cm) mark or below the 1" (2.54 cm) mark. Damage to the up/down system may result.

## 2.14 Blade Guide Arm Operation

1. Look down the length of the log to see its maximum width. The outer blade guide should be adjusted to clear the widest section of the log by less than 1" (25.4 mm).
2. Use the blade guide toggle switch on the control panel to adjust the outer blade guide as necessary. Push the switch to the left to move the arm in. Push the switch to the right to move the arm out.



See Figure 2-11.

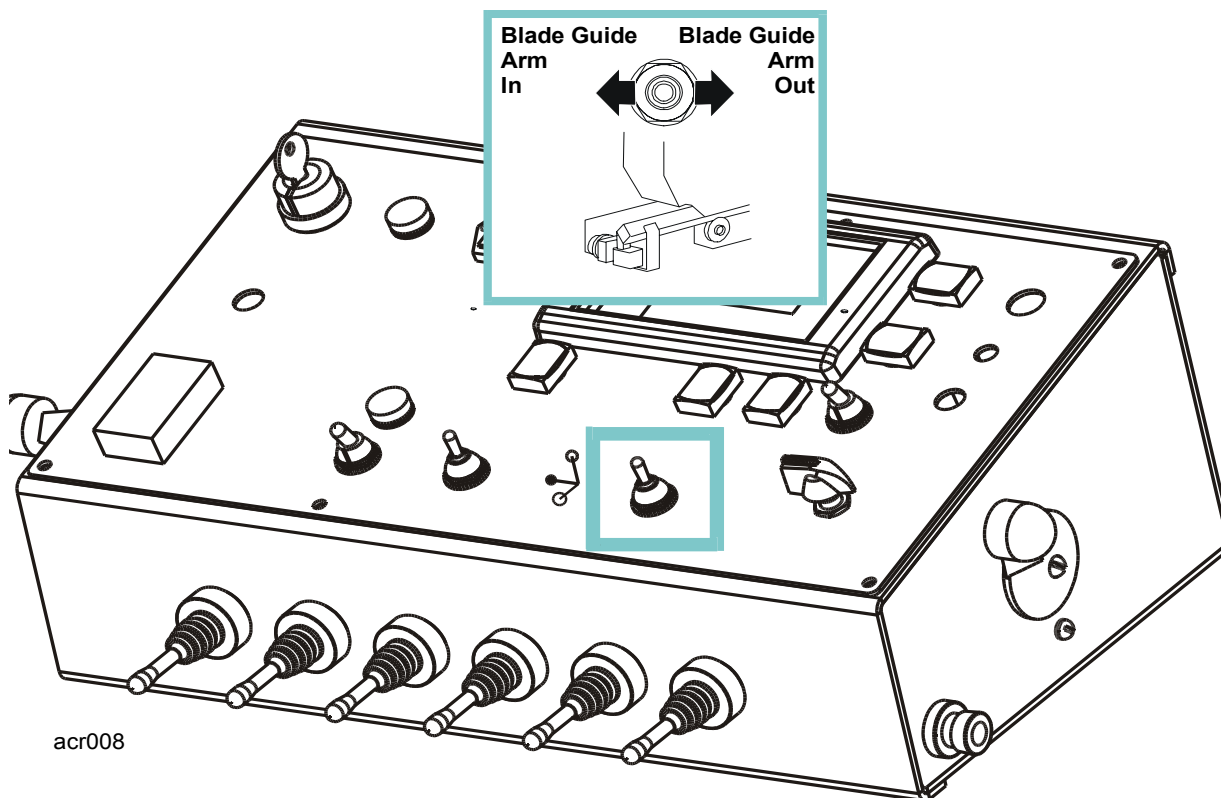

FIG. 2-11

3. Use the blade guide toggle switch to readjust the outer blade guide as you are cutting in order to keep the guide within 1" (2.5 cm) of the log. Be sure to adjust the arm back out before returning the carriage.

## 2.15 Power Feed Operation

See Figure 2-12. The power feed system moves the carriage forward and backward by using two switches on the control panel.

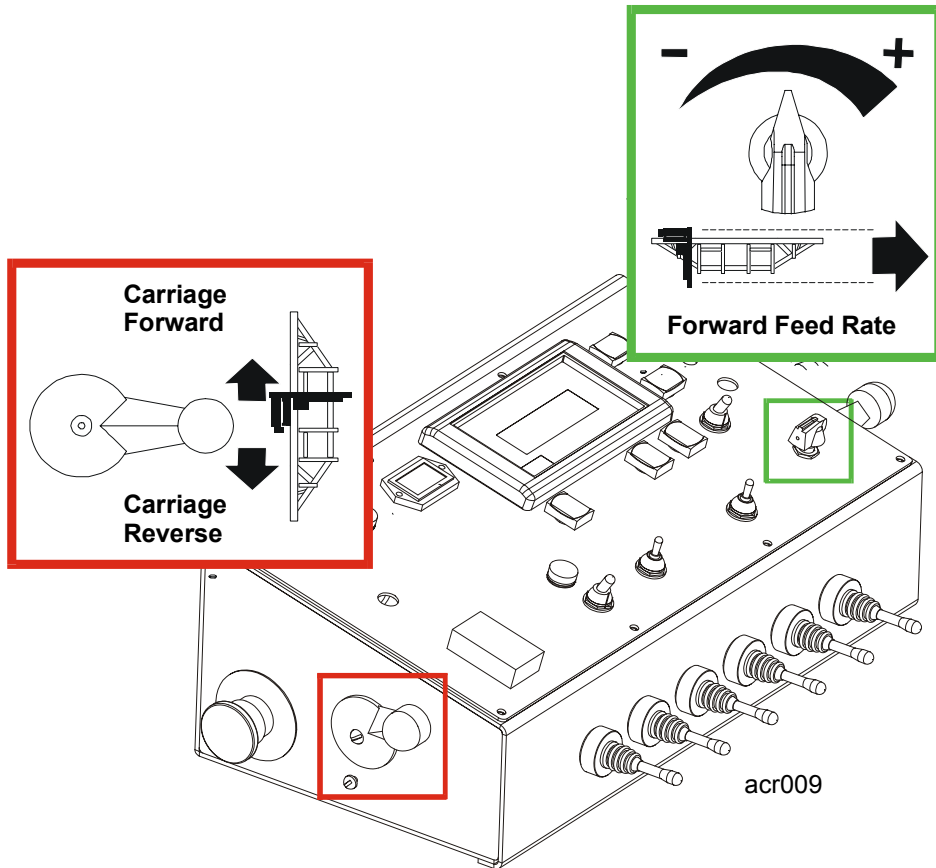

FIG. 2-12

### Carriage Feed Rate



The carriage feed rate switch controls the speed at which the carriage travels forward. Turn the switch clockwise to increase speed. Turn it counterclockwise to reduce speed.

### Carriage Forward and Reverse

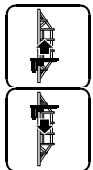

The carriage forward/reverse switch controls the direction in which the carriage travels. Turn the forward/reverse switch upward to move the carriage forward. Turn the switch down to move the carriage backward.

## 2 Setup & Operation

### Power Feed Operation

---

The middle position (as shown) is the neutral position. The power feed switch is designed to return to the neutral or "off" position when released from operating in the reverse position. If the switch remains engaged, manually move the switch to the neutral or "off" position. Repair the drum switch ([See Section 4.2](#)).

 **WARNING!** Be sure the power feed switch is in the neutral position before turning the key switch to the (#2) or (#1) position. This prevents accidental carriage movement, which may cause serious injury or death.

#### Using The Power Feed

**HINT:** To get a straight cut in the first part of the board, feed the blade into the log at a slow speed. This stops the blade from flexing and dipping up or down. Turn the carriage feed rate switch to a slow speed until the whole width of the blade has entered the cut.



Then use the carriage feed rate switch to increase the feed rate as desired. Maximum feed rate varies with width and hardness of the wood. Over-feeding results in engine and blade wear, and also produces a wavy cut.



Stop the carriage at the end of the cut by turning the carriage feed rate switch counter-clockwise until the carriage stops moving.

2. Push the STOP red button to stop the blade. Remove the board from the top of the log.



**CAUTION!** Be sure to stop the blade when returning the carriage. This will not only prevent the blade from being pulled off and ruined by a wood sliver, but also will increase the life of the blade. [See Section 2.19](#) for optional procedure for Super series mills.

3. Return the carriage to the front of the mill by turning the carriage forward/reverse switch down. The power feed motor will bypass the carriage feed rate switch and the carriage will automatically return at the fastest speed available. **Always disengage the blade before returning the carriage for the next cut.** [See Section 2.19](#) for optional procedure for Super series mills.



4. Make sure that the blade does not catch on the end of the log. Raise the carriage slightly to make sure the blade clears the log when returned. **HINT:** Try to stop the blade while the heel of the blade is still on the log. Then bring the carriage back without adjusting the blade up. This lets you keep the blade at the current height setting so you can make the next blade height adjustment more quickly.



**DANGER!** Stay clear of the area between the trailer axle and saw carriage. Failure to do so will result in serious injury.

## 2.16 Instructions for PLC-AC Networks Operation

PLC-AC Networks is a sawmill option which automatically lowers the saw head to a pre-set cutting height. The option of automatic head setting functions only for downward saw head movement. The saw head height measurement is made continuously and is independent of gear clearance, saw head chain wearing, etc. The data about saw head height are not lost even when the sawmill power is turned off and then on again. PLC-AC Networks is based on a programmable logic controller, PLC, a magnetostrictive measuring strip (which reads a given saw head height), a programmable control panel and a speed controller used in asynchronous motors.

### Networks usage principles

The following buttons are located on the Networks control panel:

1. REF – used to confirm entered or modified data (board thicknesses, blade kerf, etc.)
2. MEM 1 – first board thickness memory
3. MEM 2 – second board thickness memory, in the Manual Mode – in the display window it shows the height to which you should lower the saw head to get the whole number of the same dimension boards.
4. EXAMPLE: If the saw head height is 380 mm and you want to get boards 50 mm thick, the saw head height shown on the display will be 350 mm (which means that if you want the last board as well as the previous ones to be 50 mm thick, the saw head should be lowered to the position of 350 mm above the bed rails). Complete description of how and when to use this button you will find in further points of our instructions. **NOTE:** in the above example the kerf size was not taken into account.
5. AUTO/MANUAL – lets you switch between Manual Mode and Automatic Mode. MANUAL – Networks shows the current saw head height only, the up/down switch, located on the sawmill control panel, works in the same manner as in the sawmill without the Networks option. AUTO – automatic saw head lowering, the up/down switch is used only to initiate the saw head's downward movement or to raise the saw head after any cutting operation.
6. UP/DOWN ARROWS – used to change entered parameters such as thickness of the sawn log, blade kerf, etc.

### **Blade Kerf Setting**

For maintaining accuracy (proper thickness) of the sawn boards it is especially important to set the blade kerf. The kerf setting can be whole numbers only (not fractional ones, e.g. 1.2, 2.3). The typical Wood-Mizer blade's kerf is approximately 2 mm and that value should be entered into the Networks memory.

To change/set the blade kerf:

1. The Auto/Manual button in the Manual position.
2. Press the Ref Button.
3. The display reads "Blade kerf...mm".
4. Using the up/down arrows scroll to the desired value (typically 2 mm).
5. Press Ref again to store the setting.
6. The display should read "Stored". The kerf value has been entered into the Networks memory.

### **Simple lowering the saw head by a pre-set value:**

1. The Auto/Manual button in the Manual position.
2. Using the up/down switch move the saw head to the height from which you want to start cutting.
3. Press the Auto/Manual button to change to the Auto position.
4. Set the desired board thickness with the up/down arrows. If the blade kerf has already been set (e.g. 2 mm), the entered board thickness will be the real one i.e. after being sawn, the board will be exactly of the thickness shown on the display. Therefore you should not add the kerf value to your board thickness (e.g. you should not enter the value of 27 mm to get a 25-mm-thick board). Networks will automatically add the pre-set blade kerf to the board thickness that has been entered.
5. Press the Ref button (to confirm the board thickness setting).
6. Make a cut (when returning the saw head to the front of the mill you can raise it

- Networks remembers the last cutting height).

7. If you are ready for the next cutting, press and release the up/down drum switch handle to initiate the saw head's downward movement.
8. Wait until the display shows the message "Ready".
9. You can start cutting.

To cut next boards of the same thickness, repeat steps 7-9. If you want to change the board thickness dimension, set the new value (by using the up/down arrows or choosing one of the values stored in MEM1 and MEM2 memories) before lowering the saw head for the next cut. **Confirm the change pressing the Ref button** and then use the same procedure as described in points 7-9.

### Lowering the saw head to get a whole number of identically-thick boards

This Networks function allows you to figure the height on which the saw head should be set to get the whole number of the cut boards, i.e. each board down to the last one will be of the same thickness.

1. Position the saw head on the height from which you would start cutting.
2. Switch the Auto/Manual button to the Manual position.
3. Set the desired board thickness with the up/down arrows or choose MEM1/MEM2.
4. **Press the Ref button** to confirm the setting.
5. Press the Auto/Manual button to change to the Manual position.
6. Press MEM2.
7. The display shows the height to which the saw head should be lowered to get the whole number of the cut boards.
8. Move the up/down switch to the down position and release. The saw head will start to move down.
9. The saw head will lower to the height allowing you to get the whole number of the cut boards (each board down to the last one will be of identical thickness).
10. Switch the Auto/Manual button to the Auto position.



- 11. Press Ref to confirm.**
12. Press and release the up/down switch to move the saw head down.
13. Make a cut.
14. The remaining activities are the same as described in the chapter above.

### **Storing new board thicknesses in MEM1 and MEM2 memories**

1. The Auto/Manual in the Auto position.
2. Using the arrows set the board thickness dimension you want to program.
3. Press and hold for about 3 s the MEM1 button (or MEM2 if you want to store the new value in the second memory).
4. The stored value will appear on the display after the indication “Memory 1” (or Memory 2).
5. The stored values will remain in the Networks memory until you change the setting to another or restart (reset) the system (return to the factory values).

Press the up/down arrow again to exit the memory (MEM1 or MEM2) and return to the set board thickness display. If you want to use the setting stored in the Networks memory in the Auto Mode (the Auto/Manual button in the Auto position), press MEM1 (or MEM2) and then **confirm the chosen board thickness dimension with the Ref button.**

### **Return to the factory settings (initial)**

If Networks is not functioning properly, it may be necessary to return to the factory settings.

Networks restarting (resetting):

1. Turn the main power supply off with the main switch located on the side panel of the electric box (which is placed on the saw head).
2. Press Ref and MEM 1 and then, still holding both buttons, turn the power on.
3. Release the buttons after about 3 seconds from turning the power on.

4. The display reads “///RESET///”.
5. Networks has returned to the factory settings, the board thicknesses stored in MEM1 and MEM2 memories and the kerf setting will return to the initial values (MEM1-25 mm, MEM2-50 mm, blade kerf – 2 mm).
6. If Networks is still not working properly, contact the Wood-Mizer Customer Service.

### Restrictions/protectations:

1. The minimum thickness of the last board cannot be less than 25 mm, therefore Networks in the Automatic Mode makes it impossible to lower the saw head to the height below 25 mm. Sawing at a position lower than 25 mm may cause the top metal part of the log clamps to be cut. EXAMPLE: The current saw head height is 80 mm and we want to cut a board 60 mm thick (the kerf is set to 0). Because of the above restriction it is impossible, so the display will show the message “Insufficient height! Minimum saw head height: 25 mm”. In such a case you should lower the cutting thickness (in our example to 50 mm which will result in the saw head’s height of 30 mm).
2. The upper limit of the saw head travel is 890 mm. Networks will automatically stop the up/down motor after reaching this height. Only downward movement of the saw head will be possible then.
3. If the display shows the message “Sensor bad” or “Check sensor connections and power supply” it means that the sensor is not functioning properly. In this case the sensor’s further work is impossible. Locate cause of the failure. First inspect the connections between the sensor and the PLC unit. If they are good, check 24 V DC voltage on the 24 V DC Telemecanique power supply. Voltage should be about 24V. If the power supply is adequate and the sensor still does not work, you should restart (reset) the Networks. The description of the restart function can be found above. If the sensor and the Networks do not work after being restarted, you should contact WM service.
4. If you switch the up/down switch to the up position during the saw head’s automatic lowering (the saw head’s downward movement) in the Auto mode, the saw head’s downward movement will be stopped. Simultaneously, the data concerning the current lowering (the height to which the head should be lowered) will be lost. This function has been inserted for safety’s sake. A similar result can be obtained when the Auto/Manual button is switched to the Manual position during the saw head’s automatic downward movement.

#### 2.17 Cutting The Log

The following steps guide you through normal operation of the Wood-Mizer sawmill.

1. Once the log is placed where you want it and clamped firmly, turn the key switch to the accessory (#2) position.

2. Use the displayed ( manual mode ) blade height scale to determine where to make your first cut ([See Section 2.16](#)). Set the blade to the desired height with the up/down switch. Make sure that the blade will clear all side supports and the clamp. Adjust the outer blade guide to clear the widest section of the log by moving the blade guide toggle switch.



**NOTE:** An optional laser sight is available to help determine where the blade will travel through the log. See the laser sight manual for detailed operating instructions.

3. Make sure all covers and guards are in place. Push the green START button to start the blade spinning.

4. Start the water lube if necessary to prevent sap buildup on the blade. [See Section 2.20](#).

5. Feed the blade into the log slowly ([See Section 2.15](#)). Once the blade completely enters the log, increase the feed rate as desired. Always try to cut at the fastest speed you can while keeping an accurate cut. Cutting too slowly will waste blade life and lower production!



6. As you get to the end of the log, slow down the feed rate. When the teeth exit the end of the log, turn the feed rate all the way down.



7. Use the carriage forward/reverse switch to return the carriage to the front of the mill. Remove the slab that you have just cut from the log.



8. Repeat until the first side of the log is cut as desired. Set aside the usable flitches (boards with bark on one or both sides). You can edge them on the mill later.

9. Push the red STOP button to stop the motor.

10. Lower the toe boards, if they were used. Use the hydraulic levers to release the clamp and engage the log turner. Turn the log 90 or 180 degrees. Make sure the flat on the log is placed flat against side supports if turned 90 degrees. Make sure it is placed on bed rails if turned 180 degrees. If the log was turned 90 degrees and you are using toe boards to compensate for taper in the log, raise the front or rear toe board again on the second side of the log until the heart is parallel with the bed.



11. Repeat the steps used to cut the first side of the log until the log is square. Cut boards from the remaining cant by adjusting the blade height for the thickness of boards that you want.

**Example:** Remember that the blade cuts a 1/16 - 1/8" (1.6-3.2 mm) wide kerf. If you want 1" (25.4 mm) thick boards, lower the carriage 1 1/16 - 1 1/8" (27-28.6 mm) for each board.

## 2.18 Edging

The following steps guide you through edging boards on the Wood-Mizer sawmill.

1. Raise the side supports to 1/2 the height of the flitches, or the boards that need to be edged.
2. Stack the flitches on edge against the side supports.
3. Clamp the flitches against the side supports halfway up the flitch height. (Wider flitches should be placed to the clamp side. When they are edged, flip them over to edge the second side without disturbing the other flitches or without having to pull them from the middle of the stack).
4. Adjust the blade height to edge a few of the widest boards.
5. Loosen the clamp and turn the edged boards over to edge the other side.
6. Repeat steps 2-4.
7. Loosen the clamp and remove the boards that have good clean edges on both sides. Clamp the remaining flitches and repeat steps 2-5.

## 2.19 Optional Cutting Procedure for Super Series Mills (Remote mills)

In order to achieve maximum production rates with Super Series mills; it may be desirable to leave the blade engaged when returning the carriage. (Normal operation procedures recommend disengaging the blade before returning the carriage for maximum blade life and fuel economy.)



**DANGER!** If leaving the blade engaged for maximum production rates, make sure the off-bearer stays out of the path of the blade. Failure to do so will result in serious injury or death.



**CAUTION!** If you choose to leave the blade engaged; raise the blade to clear the log before returning the carriage. Failure to do so may cause damage to the blade and/or saw-mill.

## 2.20 Water Lube Operation

See **Figure 2-13**. The Water Lube System keeps the blade clean. Water flows from a 5-gallon (18.9 liter) bottle through a hose to the blade guide where the blade enters the log. A valve in the bottle cap controls the amount of water flow.

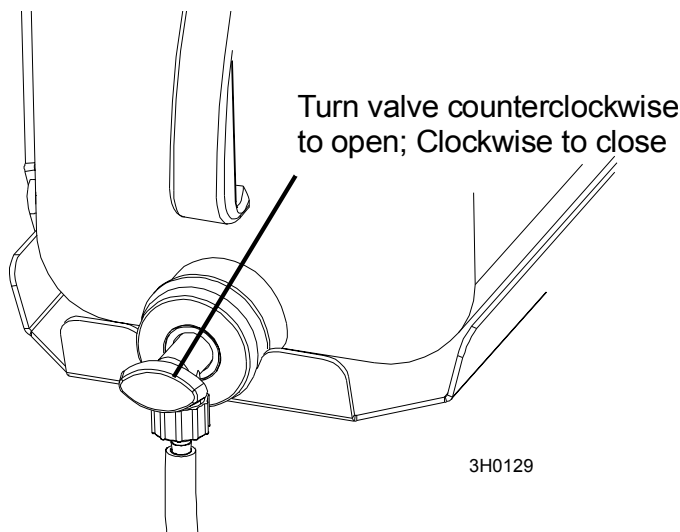

**FIG. 2-13**

Super models include a solenoid valve that will automatically start the water flow when the power feed is activated in the forward direction. The solenoid will stop the water flow when the feed switch is returned to the neutral position.

Not all types of wood require the use of the Water Lube System. When it is needed, use just enough water to keep the blade clean. This saves water, and lowers the risk of staining the boards with water. Usual flow will be 1-2 gallons (3.8-7.6 liters) per hour. A squirt of liquid dishwashing detergent in the water bottle will help clean the blade when cutting wood with a high sap content.

 **WARNING!** Use **ONLY** water with the water lube accessory. Never use flammable fuels or liquids. If these types of liquids are necessary to clean the blade, remove it and clean with a rag. Failure to do so may result in serious injury or death.

Before removing the blade, start the motor. Let the blade spin with water running on it for about 15 seconds. This will clean the blade of sap buildup. Wipe the blade dry with a rag before storing or sharpening.

If you are sawing in freezing temperatures, remove the water lube bottle from the sawmill when done sawing and store it in a warm place. Blow any remaining water from the water lube hose.

To remove water from the water valve on Super models, turn the key switch to accessory (#2), turn the feed rate knob down to '0' and place the feed switch in the forward position. Blow any remaining water from the water lube hose and valve. Return the forward/reverse switch to neutral and turn the key switch to off (#0).



## 2.21 Preparing The Sawmill For Towing

The Wood-Mizer trailer package makes transporting your sawmill easy and convenient. To get your sawmill ready for towing, follow these instructions.



**CAUTION!** If the weight of the sawmill exceeds 3,000 lbs (1361 Kg) for any reason, an auxiliary braking system must be used. Failure to do so may result in severe machine damage.

1. Move the saw carriage to the front end of the sawmill. Raise the rear outriggers.
2. Move the clamp all the way in toward the main bed frame tube.



**CAUTION!** Move the hydraulic clamp and turner to provide maximum ground clearance before towing. Failure to do so may result in damage to the sawmill.

3. Use the hydraulic controls to raise the log turner and loader as high as they will go. Manually lift the loader and hook the loader chain to the elbow of the turner. Use the hydraulic turner lever to lower the turner until the chain is tight. Push the loader lever down to bring the loader arm channels up to the loader.
4. Move the carriage forward to the travel position over the rear bed rail.
5. Position the hole in the saw head over the travel rest pin.
6. Lower the saw head until it is seated firmly on the rest pin.
7. Secure the rest pin in the vertical position with the locking pin.
8. Place the chain support bracket under the cable chain, located between the first and second bed rails.

See Figure 2-14.

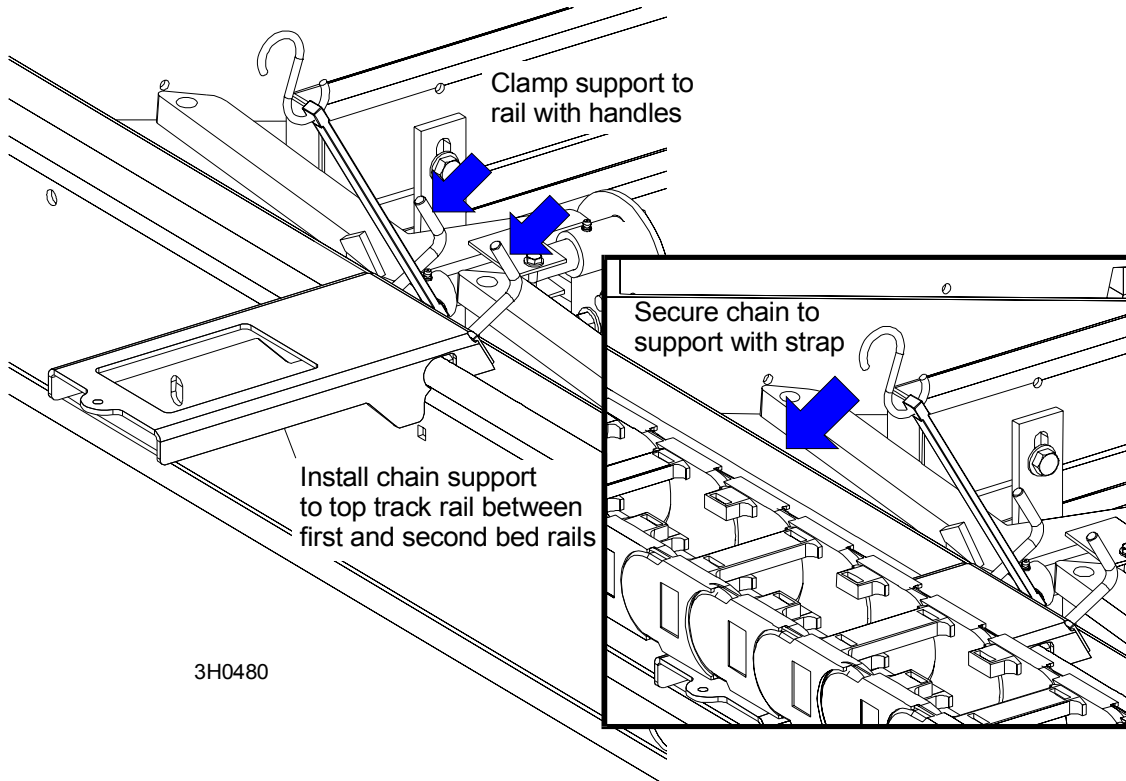

FIG. 2-14

9. Tighten the support handles and secure the chain to the support with the rubber strap.

## 2 Setup & Operation

### Preparing The Sawmill For Towing

See Figure 2-15.

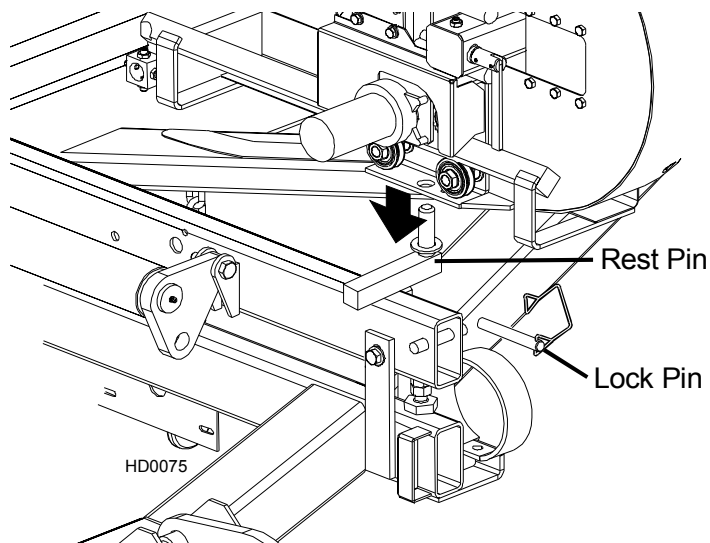

FIG. 2-15

10. Continue lowering the head 3/4" (19mm) until it contacts the stop blocks on the mast rails.



**CAUTION!** It is important that the lower stop bolts are properly adjusted to secure the carriage on the track rail. Failure to properly adjust the stop bolts can cause saw head damage, especially during mill transportation.

11. If necessary, adjust the two stops located at the bottom of the mast so the saw head contacts them after it is lowered 3/4" (19mm) past where it contacts the rest pin.

See Figure 2-16.

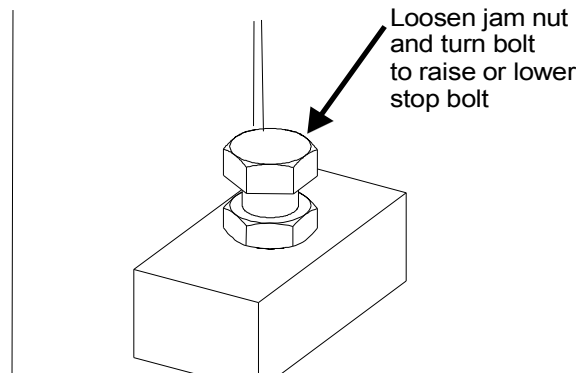

FIG. 2-16

12. Hook the carriage safety chain located at the bottom of the carriage to the bracket at the bottom of the mast.

See Figure 2-17.

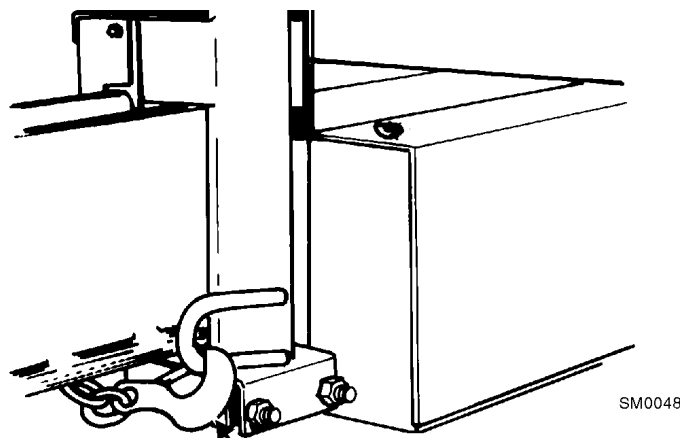

FIG. 2-17



**CAUTION!** Check to be sure the saw head safety chain is secured before towing the sawmill. Failure to properly secure the saw head can result in severe machine damage. Be sure the blade housing and pulley covers are in place and secure. Use the safety retainer pin and cable to fasten blade housing covers.

# 2

## Setup & Operation

### *Preparing The Sawmill For Towing*

---

13. Remove all loose objects from the bed of the mill. Store the outrigger jack handle in the bracket provided on the rear/loading-side outrigger guide. Reel in the winch cable. Remove the winch handle.
  
14. Place both fenders in the slots located behind the trailer tires and secure with retaining pins. Raise all but the very front outrigger.

See the trailer operator's manual for specific information regarding hitch operation and towing the sawmill.

## 2.22 Cold Weather Operation

If the sawmill is operated or stored in freezing conditions, the cable chain may freeze. Before moving the saw carriage, check to see if the chain is frozen:

1. Remove the chain support bracket ([See Section 2.2](#)).
2. Push and pull the chain by hand at a few locations to determine if chain moves freely. If you detect the chain is frozen, proceed to the recommended deicing procedure below.
3. If the chain seems to move freely by hand, use the power feed to slowly move the saw carriage toward the rear of the mill. Since the saw carriage returns only at full speed, moving the saw carriage forward will allow you to slowly engage the cable chain to be sure it is not frozen. If you detect the chain is frozen, proceed to the recommended deicing procedure below.

### ***Recommended Cable Chain deicing Procedure***

To de-ice the chain, apply a salt solution (preferably calcium chloride and water) to the entire length of the chain. Allow the solution to sit until the chain can move freely. The strength of the solution and time required to free the chain will depend on how cold the weather is and how much ice has accumulated in the chain.

Before storing the sawmill after using the salt solution, be sure to rinse the salt from any metal portions of the sawmill frame to prevent corrosion. Refer to the recommended cold-weather storage procedure below to prevent the chain from freezing.

### ***Recommended Cable Chain Ice Prevention Procedure***

Before storing the sawmill in freezing temperatures, apply a 50/50 solution of environmentally safe antifreeze (Sierra) and water to the cable chain. A garden sprayer can be used to apply the solution.

## SECTION 3 MAINTENANCE

This section lists the maintenance procedures that need to be performed.

The Short Interval Maintenance Schedule lists procedures that need to be performed every 4, 8 or 25 hours. The Maintenance Log lists procedures that need to be performed every 50, 100, 200, or 1000 hours. Keep track of machine maintenance by filling in the machine hours and the date you perform each procedure.

 **This symbol** identifies the interval (hours of operation) at which each maintenance procedure should be performed.

Be sure to refer to option and engine manuals for other maintenance procedures.

### 3.1 Wear Life

**See Table 3-1.** This chart lists estimated life expectancy of common replacement parts if proper maintenance and operation procedures are followed. Due to the many variables which exist during sawmill operation, actual part life may vary significantly. This information is provided so that you may plan ahead in ordering replacement parts.

Part Description	Estimated Life
B57 Blade Wheel Belts	500 hours
Up/Down Drum Switch	1000 hours
Blade Guide Rollers	1000 hours
Power Feed Drum Switch	1200 hours
Drive Belt	1250 hours
Power Feed Belt	2000 hours
Up/Down Belt	2000 hours

**TABLE 3-1**

## 3.2 Blade Guides

1. Check the rollers for performance and wear every blade change. Make sure the rollers are clean and spinning freely. If not, rebuild them. Replace any rollers which have worn smooth or have become cone shaped. See The LT40S/M/L DH Parts manual for blade guide rebuild kits and complete roller assemblies.

See Figure 3-1.

2. Make sure the blade screw in the top center of the C-frame is 1/16" (1.5 mm) below the bottom of the blade. If not, loosen the nut and adjust the screw as necessary. Check the screw every blade change. Failing to maintain this adjustment will lead to early blade breakage.

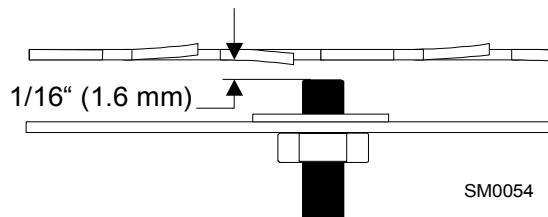

FIG. 3-1

## 3.3 Sawdust Removal

1. Remove the excess sawdust from the blade wheel housings and sawdust chute every blade change.
2. Remove all sawdust and debris from around the velocity fuse valves every 8 hours of operation. The valves are located at the bottom of the log loader cylinders.
3. Remove sawdust buildup as necessary from top rail cover.



**CAUTION!** Failure to remove sawdust buildup from track rail cover could result in damage to these parts when the saw head is lowered to its lowest position.

4. As required, remove sawdust buildup from the power feed belt housing. Turn the control panel key switch to OFF (0) and remove the key. Disassemble the power feed belt cover and remove sawdust buildup in and around the power feed belt and pulleys. Replace the power feed belt cover.



### 3.4 Carriage Track, Wiper & Scrapers

See Figure 3-2.

1. Clean the upper and lower track rails to remove any sawdust and sap buildup every eight hours of operation. Lubricate the lower track rail by wiping it with Dexron III ATF.
2. Remove sawdust from the upper cam housings. Loosen the thumb screws on the upper cam housing covers and open. Brush any sawdust buildup from the housings.
3. Check the track scrapers as needed. Make sure the scrapers fit firmly against the rail. If a track scraper needs to be adjusted, loosen the thumb screw, push the scraper downward until it fits firmly against the rail, and retighten the thumb screw.

Clean and lubricate the upper track wiper every twenty-five hours of operation. Unbolt the wiper, remove it from the sawmill, and remove any sawdust buildup. Soak the felt wiper with Dexron III transmission fluid, 10W30 motor oil.

**CAUTION!** Reinstall the track wiper so that it lightly touches the track rail. If the wiper presses too firmly against the rail, it can cause the power feed to bind.

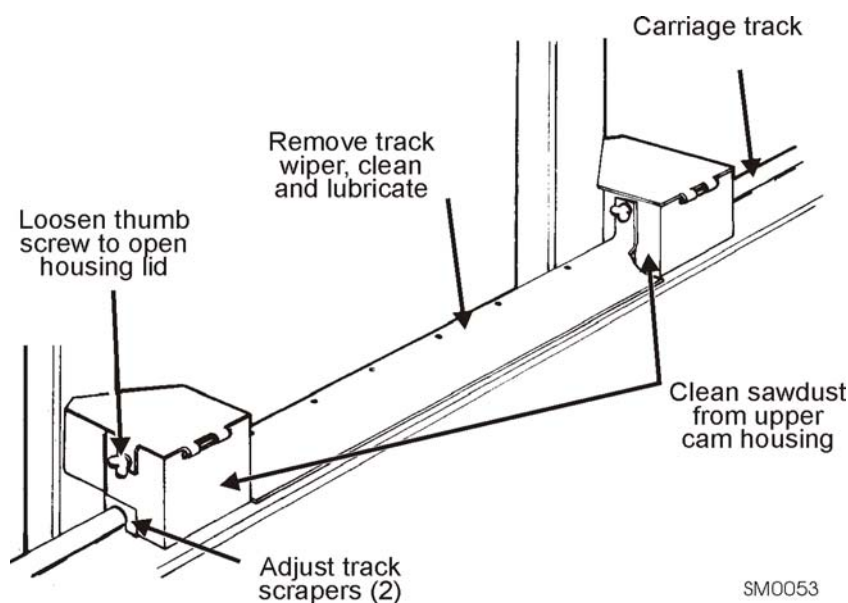

FIG. 3-2

### 3.5 Vertical Mast Rails

50 Clean and lubricate the vertical mast rails every 50 hours of operation. Clean with solvent and remove any rust with a light-grade sand paper or emery cloth. Lubricate the mast with motor oil or automatic transmission fluid (ATF).



**CAUTION!** Never use grease on the mast rails as it will collect sawdust.

### 3.6 Drum Switches

50 Lubricate the up/down and power feed drum switch contacts inside the control panel every fifty hours of operation. Use only contact grease supplied by Wood-Mizer. Remove the control panel cover. Use a cotton swab to apply grease to the switch contact ends.



**WARNING!** Drum switch grease contains Petroleum Hydrocarbon Lubricant. Eye and skin irritant. If introduced into eyes, flush with water for at least 15 minutes. If film or irritation persists, seek medical attention. Wash skin with soap and water. If ingested, do not induce vomiting - contact a physician. KEEP OUT OF THE REACH OF CHILDREN.

### 3.7 Miscellaneous

1. Apply a thin film of a NLGI No. 2 grade lithium grease to the blade guide arm every fifty hours of operation to help prevent it from rusting.
2. Grease the clamp mechanism, loading arm, and side supports with a NLGI No. 2 grade lithium grease every fifty hours of operation.
3. Oil all chains with Dexron III ATF every fifty hours of operation.



**CAUTION!** Do not use chain lube. It causes sawdust buildup in chain links.

4. Check the mill alignment every setup. See Section 5, Alignment.
5. Make sure all safety warning decals are readable. Remove sawdust and dirt. Replace any damaged or unreadable decals immediately. Order decals from your Customer Service Representative.

### 3.8 Blade Tensioner

1. Lubricate the chrome rods of the tensioner system with a heavy duty teflon spray lubricant, such as Gunk L508, every fifty hours of operation.
2. Lubricate the tensioner screw handle with a NLGI No. 2 grade lithium grease as needed.

50

See Figure 3-3.

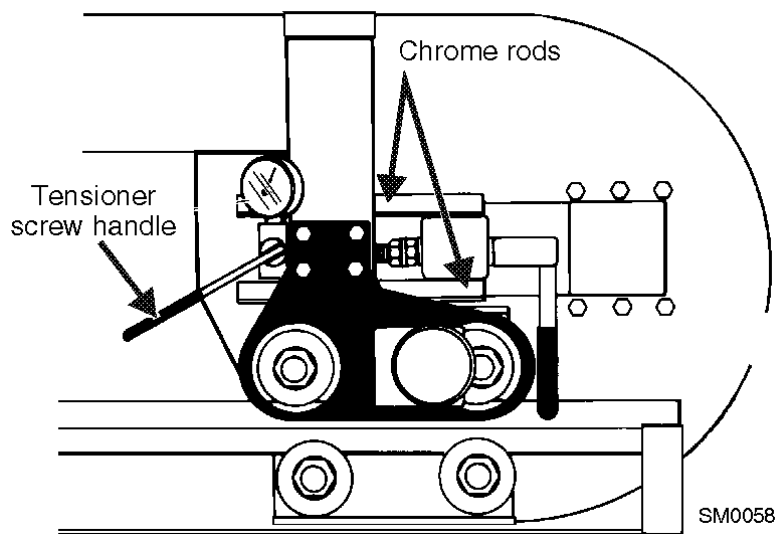

FIG. 3-3

3. Add an Automatic Transmission Fluid (ATF) such as Dexron III ATF to the hydraulic blade tensioner as needed.

See **Figure 3-4**. To add enough fluid to completely fill the tensioner block:

- Remove the tensioner handle and ball. Remove the sawmill blade housing covers, blade and idle-side blade wheel.
- Push the idle-side shaft housing all the way in to collapse the rear tensioner piston and fully extend the front piston. The front piston should reach the threaded area of the piston guide.

**NOTE:** If the hydraulic fluid level is extremely low, collapsing the rear piston may not fully extend the front piston. If it does not, finish the fill procedure in its entirety and repeat. The first pass should add enough fluid to allow the front piston to fully extend. The second pass should add enough fluid to completely fill the block.

- Locate the fill plug behind the tension gauge. Clean any dirt and debris from the plug area. Use a 7/16" wrench to remove the plug, making sure to keep the plug o-ring with the plug.
- Manually extend the rear piston (the front piston should remain extended).
- Use a small funnel or cup to completely fill the block with hydraulic fluid. When full, place the fill plug in the fill plug hole and thread 1-2 turns. Manually push the rear piston all the way in to allow excess oil and air to bleed from system through the plug. Tighten the plug all the way.
- Reinstall the idle-side blade wheel, blade and blade housing covers. Reinstall the tensioner ball and handle.

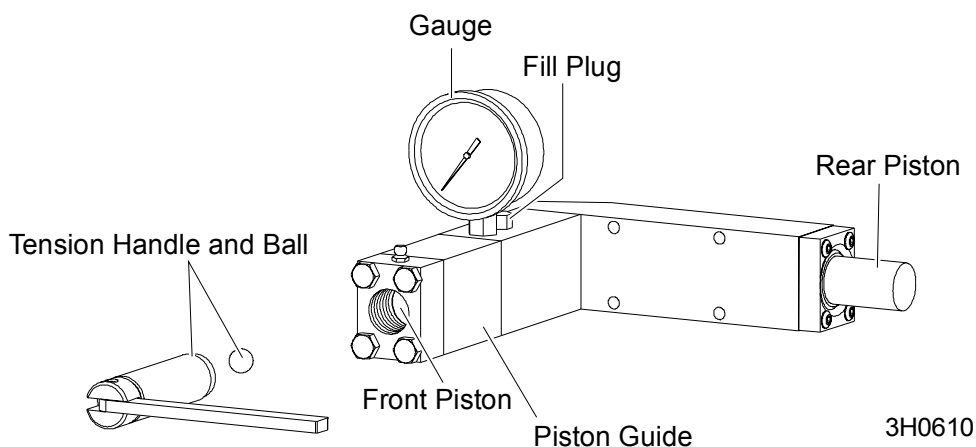

**FIG. 3-4**

### **3.9 Blade Wheel Belts**

1. Rotate the blade wheel belts and check them for wear. Rotating the belts every 50 hours will give you longer belt life. Replace belts as necessary. Use only B57 belts manufactured by Goodyear or Browning.
2. Periodically check all belts for wear. Replace any damaged or worn belts as needed.



### 3.10 Drive Belt Adjustment



**WARNING!** Do not for any reason adjust the engine drive belts or belt support bracket with the engine running. Doing so may result in serious injury.



**See Table 3-2.** Check the drive belt tension after the first 20 hours, and every 50 hours thereafter. See the table below for drive belt tension specifications for your model sawmill.

Engine/Motor	Belt Tension
E20	7/16" (11mm) deflection with 16 lbs. of deflection force
E25	7/16" (11mm) deflection with 16 lbs. of deflection force

**TABLE 3-2**

### 3.11 Hydraulic System

1. Check the hydraulic fluid level every fifty hours of operation. Add fluid as necessary. The level in the hydraulic pump should be 3/4" (19mm) from the top with all cylinders collapsed.

If humidity is a problem or the mill is used outside in humid weather, drain and replace two quarts (.95 liters) of fluid every six months. This will drain any accumulated water and help prevent pump failure due to water ingestion. It also will prevent excessive fluid wear and allow the fluid to maintain its hot end performance. If humidity is not a problem, drain and replace one gallon (3.8 liters) of fluid every year to prevent fluid wear.

**See Figure 3-5.** If you are operating in temperatures -20° to 100° F (-29° to 38° C), use an all-weather hydraulic fluid such as Exxon Unavis J26. For alternate fluids and/or other temperature ranges, refer to the chart below. Operating above the recommended temperature range of a fluid could result in excessive pump wear. Operating below the recommended temperature range could result in reduced hydraulic cylinder speed. To change fluid types, replace one gallon of the current fluid with one gallon of the alternate fluid.

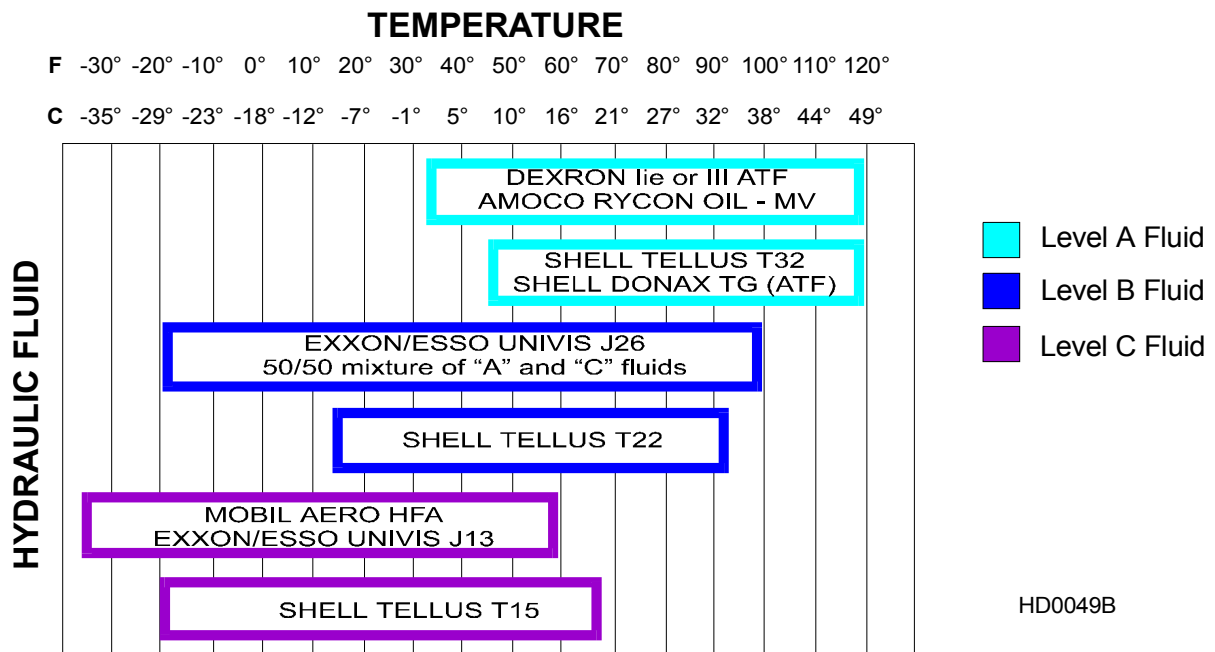

**FIG. 3-5**

2. Replace the hydraulic system cartridge filter every 500 hours of operation.
3. Periodically check all hydraulic lines and fitting as needed. Replace as necessary.



### 3.12 Drive Bearing

500 Refill the fluid in the drive-side cylinder bearing housing every 500 hours of operation. Remove the top and bottom oil plugs. Pour an Automatic Transmission Fluid (ATF) such as Dexron III ATF into the top hole until it begins to flow from the bottom hole. Reinstall the square oil plug to the bottom hole and the vented oil plug to the top hole.

See Figure 3-6.

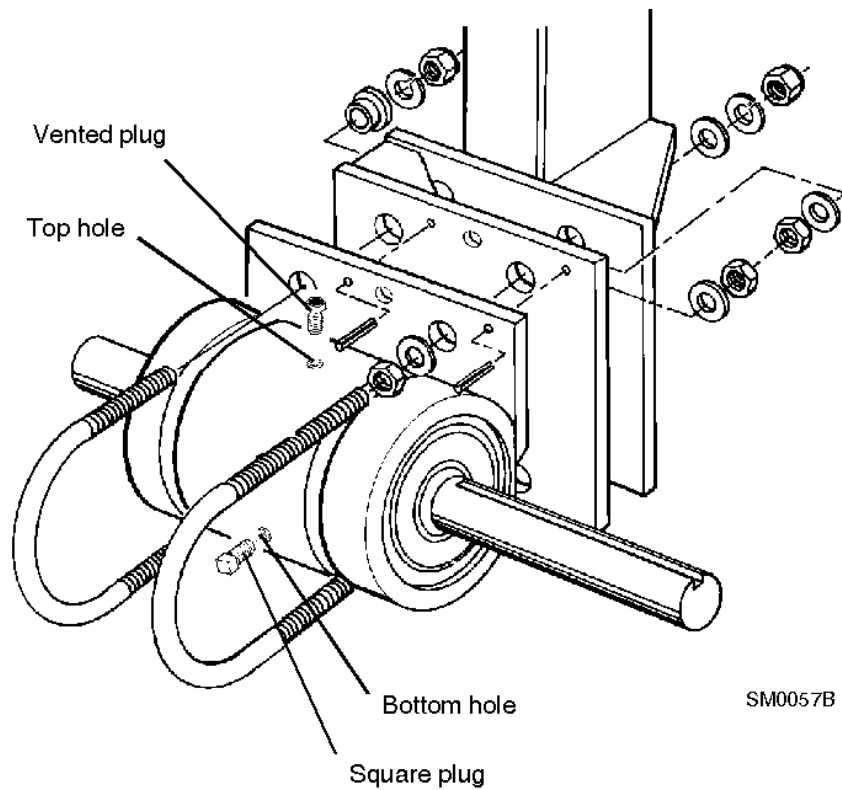

FIG. 3-6

### 3.13 Up/Down System

1. Grease the up/down gear reducer shaft bearing with a NLGI No. 2 grade lithium grease every 1000 hours of operation.

See Figure 3-7.

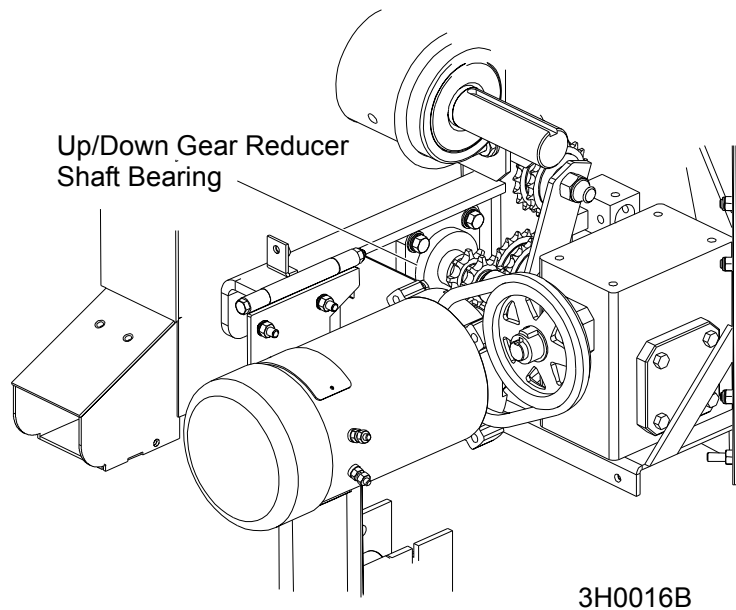

FIG. 3-7

2. Super model up/down systems feature a spring loaded belt design. Belt tension is automatically maintained and requires no adjustment. Replace the belt when adequate belt tension can no longer be obtained.



**WARNING!** Always secure the cutting head with a chain or a brace before removing the up/down motor belt. The cutting head may fall, causing severe injury or death.

- Adjust the up/down chain tension as needed. Measure chain tension with the head all the way to the top of the vertical mast. Secure the carriage with a chain at the top, or shim it underneath. Find the chain adjusting bolt at the bottom of the mast, behind the battery box. Adjust the bolt until the center of the chain can be deflected  $3/4"$  (1.9cm) forward *and*  $3/4"$  (1.9cm) backward with a 5 lb. (2.3 Kg) deflection force.



**WARNING!** Always secure the cutting head with a chain or a brace before adjusting the up/down chain. The cutting head may fall, causing severe injury or death.



**CAUTION!** Do not over-tension the chain. Over-tensioning the chain may lead to early failure of the gear reducer.

See Figure 3-8.

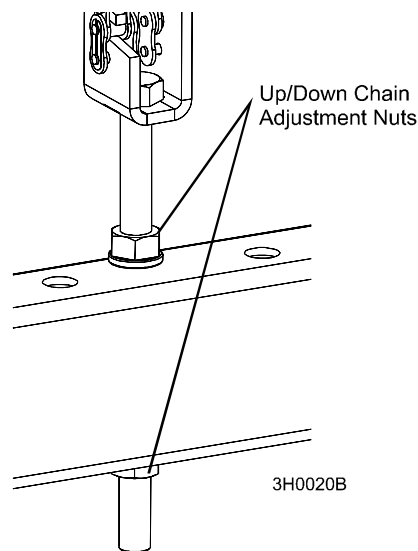

**FIG. 3-8**

- Check the up/down gearbox oil level. Add a synthetic gear oil such as Mobil SHC 634 as needed.

Wood-Mizer offers replacement gear oil in 8 ounce bottles (2 required for complete oil replacement).

### 3.14 Power Feed

1. Adjust the power feed belt as needed. When the power feed belt gets loose, it will begin slipping. This causes the carriage to not move forward when cutting. To retighten the belt:

**See Figure 3-9.** Remove the four cover bolts and belt cover and measure the belt tension. The belt should be tightened so there is 1/8" (3 mm) deflection with a 7 lb. (3.2 Kg) deflection force. To adjust the belt tension, loosen the four motor mount bolts. Place a wrench on the jam nut and turn the adjustment bolt clockwise to tighten the belt. Retighten the motor bolts and replace the feed motor cover.

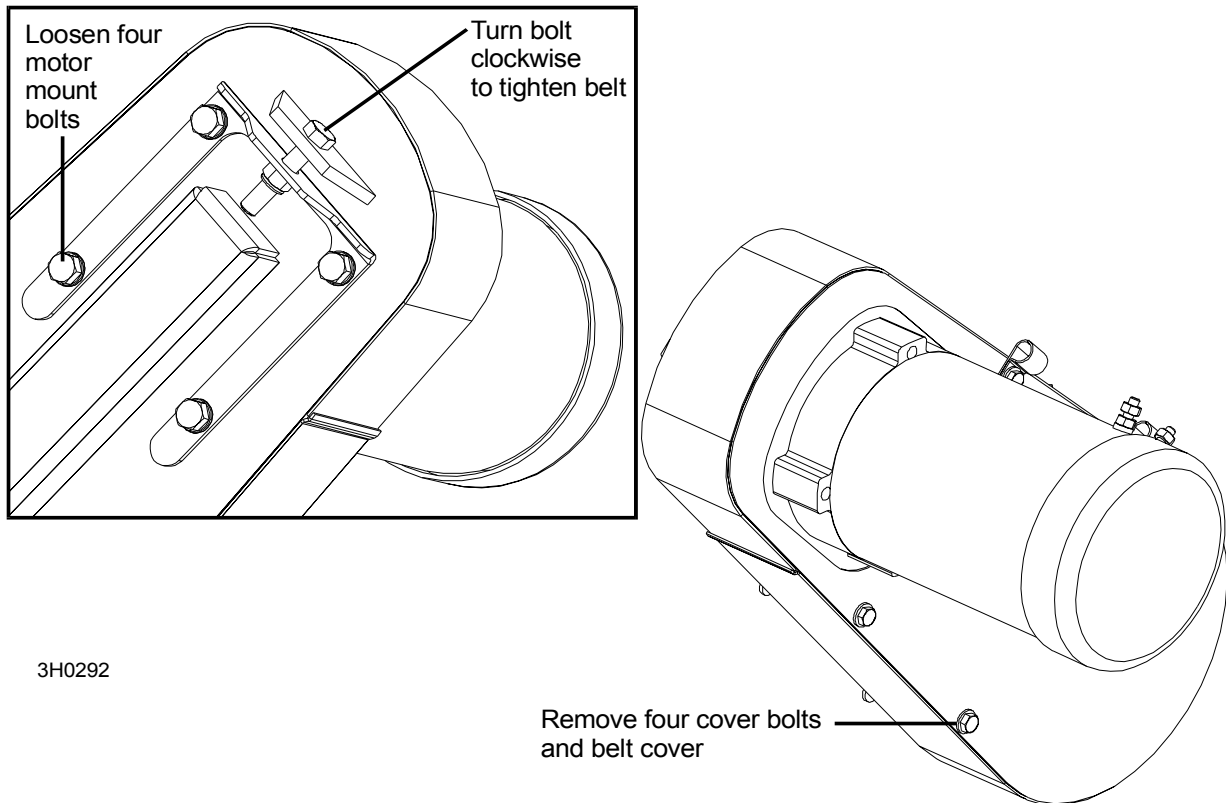

3H0292

FIG. 3-9

# 3

## Maintenance

### Power Feed

---

2. Adjust the power feed chain as needed. Measure the power feed chain tension with the saw head all the way toward the front of the mill. Use the two lock nuts at the rear of the mill to tighten or loosen the power feed chain. Adjust the chain until it measures 7 to 8 inches (17.8 to 20.3 cm) from the top of the top rail at its lowest point.



**CAUTION!** Do not overtighten the feed chain. Damage to the power feed motor may result.

See Figure 3-10.

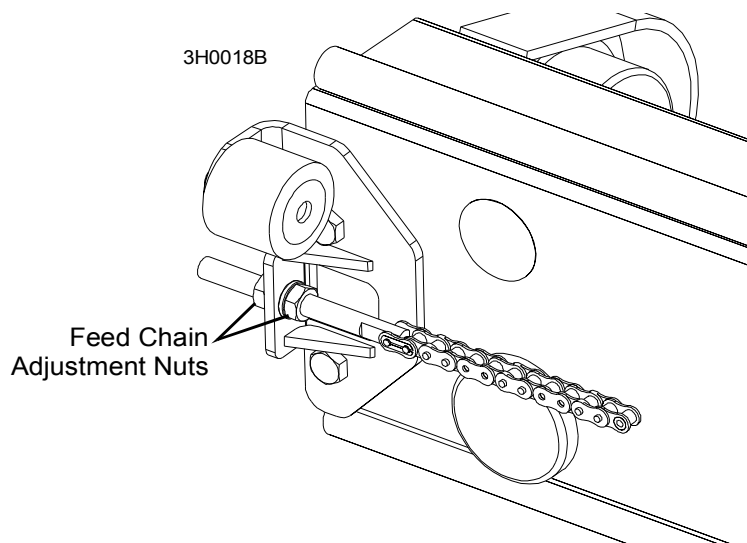

**FIG. 3-10**

### 3.15 Clean The Cable Chain & Support Tray

As you operate the sawmill, be aware of any pieces of debris that may fall on the cable chain and/or support tray. Stop the sawmill and immediately remove any pieces of wood, bark or anything else that may divert the path of the chain or cause it to jam.

Clean the cable chain and support track of sawdust buildup every eight hours of operation. Blow or brush the sawdust from the track and tray and remove any accumulated sawdust that is high enough to contact the chain/tray.

### 3.16 Cable Chain Repair

If a component of the cable chain breaks or is missing, replace the component.



**CAUTION!** Do not operate the remote sawmill if the cable chain is damaged or components of the chain are missing. The chain components are interlocking and continued operation will cause more damage to the chain.

**See Figure 3-11.** To disassemble the chain use a screwdriver to pry the connecting links apart. After removing the connecting links, the side plates can be disassembled by pulling them apart at an angle.

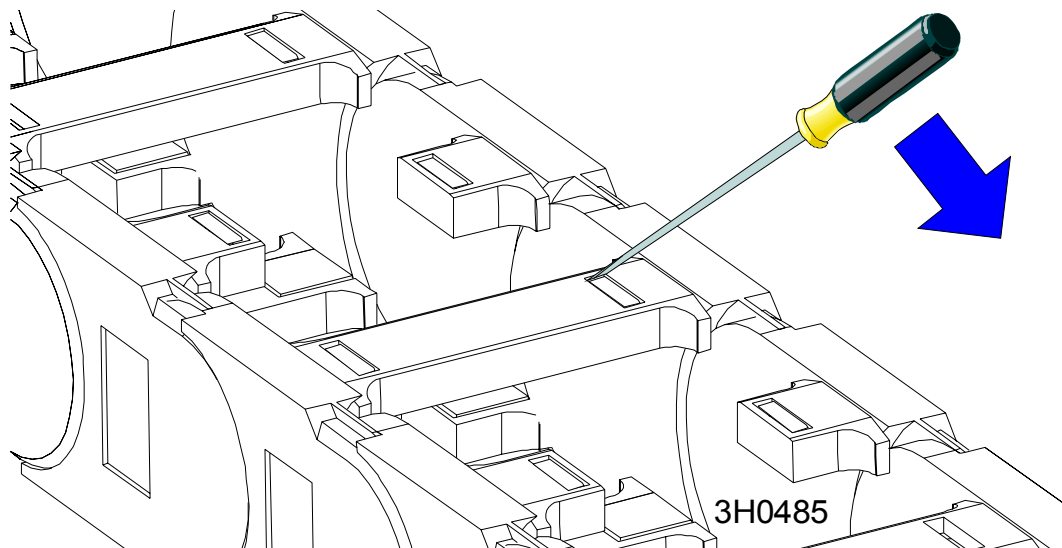

FIG. 3-11

## SECTION 4 TROUBLESHOOTING GUIDE

### 4.1 Sawing Problems

<b>PROBLEM</b>	<b>CAUSE</b>	<b>SOLUTION</b>
<b>Blades Dull Quickly</b>	Dirty logs	Clean or debark logs, especially on entry side of the cut
	When grinding teeth, heating too much and causing teeth to soften	Grind just enough metal to restore sharpness to the teeth. Use water/coolant while sharpening blade
	Poor sharpening techniques	Make sure the tip is being sharpened completely (See Sharpener Manual)
<b>Blades Break Prematurely</b>	Rubber belts on blade wheels worn to a point that blade contacts metal pulley - look for shiny spots on edge of wheels	Change blade wheel belts (B-57)
	Poor sharpening techniques	See Sharpener Manual
	Tension too tight	Tension blade to recommended specifications
<b>Blade Does Not Track Right on Drive Wheel</b>	Cant adjustment is incorrect	Readjust
	Flat/worn belts	Replace B-57 belts
<b>Blade Guides Do Not Spin While Cutting</b>	Frozen bearings	Replace bearings
	Stiff bearings	Grease bearings
<b>Drive Belts Wear Prematurely or Jump</b>	Engine/motor and drive pulleys out of alignment	Align pulleys <a href="#">See Section 4.5 Motor and Drive Pulleys Alignment.</a>

<b>PROBLEM</b>	<b>CAUSE</b>	<b>SOLUTION</b>
<b>Boards Thick Or Thin On Ends Or Middle Of Board.</b>	Stress in log which causes log to not lay flat on the bed.	After log has been squared, take equal cuts off opposing sides. Take a board off the top. Turn the log 180 degrees. Take a board off. Repeat, keeping the heart in the middle of the cant, and making it your last cut.
	Set in teeth.	Resharpener and reset blade.
	Bed rails misaligned.	Realign sawmill.
<b>Height Adjustment Jumps or Stutters When Moving Up or Down.</b>	Mast needs lubrication.	Lubricate mast track surface.
	Up/down chain improperly adjusted.	Adjust up/down chain.
	Vertical wear pads are too tight.	Adjust pads.
<b>Lumber Is Not Square</b>	Drive belt(s) loose.	Adjust belts.
	Vertical side supports not square to bed	Adjust side supports.
	Blade not parallel to bed rails	Adjust bed rails parallel to blade.
<b>Sawdust Builds Up On Track</b>	Sawdust or bark between cant and bed rails	Remove particles
	Tooth set problems	Resharpener and reset blade
	Excessive oiling	Do not oil track
<b>Wavy Cuts</b>	Track wipers worn	Adjust wipers to firmly contact track
	Track is sticky	Clean track with solvent and apply silicone spray
	Excessive feed	Slow feed rate
	Improperly sharpened blade (This will be the problem 99% of the time!)	Resharpener blade (See Sharpener Manual - read entire manual!)
	Blade guides improperly adjusted	Adjust blade guides.
	Sap buildup on blade	Use Water Lube.
	Tooth set problem	Resharpener and reset blade



## 4.2 Electrical Problems

<b>PROBLEM</b>	<b>CAUSE</b>	<b>SOLUTION</b>
<b>Up/down Excessively Slow.</b>	Vertical wear pads too tight.	Adjust pads.
	Up/down belt loose.	Adjust belt to be as loose as possible without slipping
<b>Up/down Or Power Feed Motors Do Not Work.</b>	Worn/dirty contacts in drum switch.	Replace switch or remove control panel cover and clean contacts.
	Bad key switch.	Replace key switch.
	Burned-out motor.	Replace motor.
	Up/down motor relay damaged.	Have a qualified electrician replace the relay.
	Up/down motor is damaged.	Have a qualified electrician replace the up/down motor.
	One phase lacks.	Check circuit breakers in the connectors.
	Motor thermal protector started to work.	Let the motor cool and then reset the thermal protector.
	Speed speed controller circuit overloaded.	Turn off the power and let the motor cool. Turn the power back on.
<b>Power Feed Motor Does Not Work.</b>	Speed controller is overheated.	Turn off the power abd let the motor cool. Turn the power back on.
	Short circuit in speed switch motor system.	Have a qualified electrician remove the short circuit.
	Sawdust buildup in the power feed pulleys.	Sawdust buildup puts mechanical bind on power feed which causes automatic motor protection circuit to activate. Remove sawdust from pulleys and operate normally. If motor does not operate after sawdust removal, reset 70 amp circuit breaker on the front of the control box.

<b>Up/Down Or Power Feed Switches Remain Engaged When Switch Is Released.</b>	Worn or dirty contacts in drum switch.	Manually move the power feed or up/down switch back to neutral or "off" position. Replace drum switch or remove control panel cover and clean and lubricate contacts NOTE: Use only contact grease supplied by Wood-Mizer.
	Drum switch spring broken.	Manually move the power feed or up/down switch back to neutral or "off" position. Replace drum switch spring.
<b>Up/Down Or Power Feed Motors Overheat And Loose Power.</b>	System overload or bind occurred.	Correct problem. <a href="#">See Section 4.3 Power Feed Problems.</a> Allow motor to cool before restarting.
	Normal operation factors exceeded (eg: up/down control jockeyed excessively).	Allow motor to cool before restarting.
<b>Everything Works And Then Cuts Out - Works Again.</b>	Bad fuse, or ground connection.	Check and tighten connections.
<b>Nothing Works Electrically.</b>	Blown fuse.	Replace.
<b>Intermittent Or Permanent Loss Of Accessory Motor Functions Occurs (Up/down, Fwd/rev, Blade Guide Functions Do Not Work).</b>	Bad connections at accessory solenoid or bad solenoid.	Check all connections at accessory solenoid. If connections are good, replace solenoid.

### 4.3 Power Feed Problems

<b>PROBLEM</b>	<b>CAUSE</b>	<b>SOLUTION</b>
<b>Power Feed Is Jerky At Low Speeds Or Does Not Move Until Speed Is Above Halfway Mark.</b>	Drum switch is dirty.	Clean drum switch and lubricate with contact grease supplied by Wood-Mizer.
	Drum switch contacts are bad	Check that contacts are in good condition and positively close circuit.
	Speed switch is worn.	Replace the speed switch.
<b>Power Feed Is Jerky, But Power Feed Motor Runs Properly At All Speeds.</b>	Speed switch is blocked.	Turn off the power for 20 seconds and turn it back on.
	Problem is mechanical.	Refer to the Mechanical Test.
<b>Power Feed Is Sluggish, Trips Circuit Breaker Or Current Limit.</b>	Sawdust buildup in power feed cover.	Remove power feed belt cover and remove sawdust.

<b>PROBLEM</b>	<b>CAUSE</b>	<b>SOLUTION</b>
<b>Power Feed Motor Overheats.</b>	Middle track oiler is dragging.	Clean middle track oiler and lubricate with 30-weight oil or ATF (Automatic Transmission Fluid) such as Dexron II. Allow motor to cool before restarting.
	Ground is not level.	Level mill with carpenter's level. Allow motor to cool before restarting.
	Track roller bearing drag is excessive.	Lubricate bearings; Replace tight bearings. Allow motor to cool before restarting.
	Lower track rollers are not aligned properly.	Check stop block clearance from lower bed rail. Allow motor to cool before restarting.
	Chain is dragging.	Make sure chain is centered on cam follower bearing; Clean and lubricate chain; Adjust chain tension. Allow motor to cool before restarting.
	Chain is improperly tensioned.	Adjust chain tension. Allow motor to cool before restarting.
	Seat load is excessive.	Check seat bearings for freedom of movement; Loosen clamping screw 1/4 turn. Allow motor to cool before restarting.
	Power feed is binding.	Adjust belt tension; Check condition of belt, pulleys, bearings, and sprocket; Check motor for ground fault. Allow motor to cool before restarting.
	Saw head load is excessive.	Avoid unnecessary modifications to saw heads that would give them extra weight. Allow motor to cool before restarting.
	Blade is dull or improperly set.	Use proper blade maintenance procedures (See Sharpener or Toothsetter manual). Allow motor to cool before restarting.

## 4.4 Hydraulic Problems

<b>PROBLEM</b>	<b>CAUSE</b>	<b>SOLUTION</b>
<b>You Can Actuate Any Hydraulic Handle, But Get No Response From The Pump.</b>	Carriage not positioned properly to provide power to the pump	Make sure carriage contact bracket is adjusted far enough forward for battery positive contact to touch 6ft. strip on main tube. Check contact and strip for tarnish or loose wires. Clean as necessary
	Hydraulic feeder does not work	Turn on the power switch on the front side of the electric box mounted on the front side of the hydraulic box. Check whether the power is on (in position "1")  Check whether the key switch is in ACC position
		Disconnect the plug on the left side of the electric box and change the phases using a screwdriver  Check whether the emergency switch is off
	One phase lacks power	Check fuses in the electric connenctor
	Pump motor relay damaged	Have a qualified electrician change it
	Hydraulic pump motor is overheated	Let the motor cool. When the motor is off, reset the thermal motor breaker located in the electric box monted in the hydraulic box
	The hydraulic feeder works despite the release of the hydraulic control lever	<b>Standard situation.</b> Hydraulic feeder assembly should keep working for 5-8 seconds after the hydraulic lever is released (in the neutral position)
	Poor ground connection	Check ground connection between pump and saw frame. Check contact and rail for tarnish or loose wires. Clean as necessary

	Blown fuse	Replace
	Defective pump motor	Remove motor from pump and inspect. Repair or replace as necessary
<b>You Can Get Response From the Pump By Actuating All But One or Two Handles</b>	Valve assembly switch contacts are not properly adjusted	Locate the valve switch at the bottom of the valve assembly. Use a 3MM allen wrench to loosen the set screw on each of the five switch contacts. Press each contact to the valve block and tighten the contact set screw to secure in place. <b>CAUTION!</b> Do not overtighten!  <b>NOTE:</b> Do not adjust the valve switch or switch spring; they have been preset at the factory.

## 4

## Troubleshooting Guide

### Hydraulic Problems

PROBLEM	CAUSE	SOLUTION
<b>Pump Motor Runs With Little Or No Response From The Cylinders</b>	Low fluid level	Check fluid level. Add an all-season hydraulic fluid such as Amoco Rycon Oil MV or Mobil Multipurpose ATF (automatic transmission fluid) until level is 4 - 4 1/2" from bottom of reservoir with all cylinders retracted
	Pressure relief valve moved from proper setting	Adjust pressure relief valve.
	Low air temperature causing fluid to thicken	Allow fluid to warm up. Synthetic fluids are available that allow for hydraulic operation in cold weather conditions (Mobil SHC 526)
<b>Fluid Leaks From Around Cylinder Piston Ram</b>	Worn seals	Replace seals in cylinder. Check piston ram for abrasive weld that may be causing premature seal failure
<b>Fluid Leak Around Pump Box</b>	Loose seal or fitting	Wipe pump off completely to locate cause of leak. You may have to unbolt the pump to wipe behind it. <b>NOTE:</b> Movement of the sawmill can cause fluid to slosh up into the foam filter in the reservoir cap, and subsequently spray out, giving the appearance that fluid is leaking from the pump

<b>PROBLEM</b>	<b>CAUSE</b>	<b>SOLUTION</b>
<b>Hydraulic Side Supports Go Down Before Or At Same Time As Log Turner</b>	Dirt in sequence valve	Remove sequence valves and clean thoroughly with kerosene. <b>NOTE:</b> Be sure to reassemble the valve and install it in its original position on the cylinder
	Retainer in sequence valve worn	Replace sequence valve
	Low air temperature causing fluid to thicken	Allow fluid to warm up. Synthetic fluids are available that allow for hydraulic operation in cold weather conditions (Mobil SHC 526)
<b>Hydraulic Turner Goes Up Before Or At Same Time As Side Supports</b>	Spring weakening in sequence valve	Locate sequence valve at top of turner cylinder. Turn heavy spring in about 1/4 turn
	Dirt in sequence valve	Remove sequence valves and clean thoroughly with kerosene. <b>NOTE:</b> Be sure to reassemble the valve and install it in its original position on the cylinder
	Retainer in sequence valve worn	Replace sequence valve
	Low air temperature causing fluid to thicken	Allow fluid to warm up. Synthetic fluids are available that allow for hydraulic operation in cold weather conditions. (Mobil SHC 526)
	Springs weakening in sequence valve.	Locate sequence valve at bottom of turner cylinder. Turn heavy spring in about 1/4 turn



## 4.5 Motor and Drive Pulleys Alignment

1. Install the drive belt.
2. Use a straight edge to align the engine/motor pulley to the drive pulley. Also check that the engine pulley is within 1/8" square with the drive pulley. Loosen the engine mounting bolts and rotate the engine if necessary.
3. Check front-to-back movement of the engine does not exceed 1/4". Tighten the motor mount U-bolts if necessary.
4. Engage the clutch handle and adjust the drive belt tension to 7/16" deflection with 10 lb. of force.
5. Recheck the pulley alignment and engine squareness with the clutch handle engaged. Adjust if necessary.
6. Adjust the drive belt support to 1/4" ( $\pm 1/32$ ) from the belt while engaged.

## 4.6 Power Feed Variable Speed Switch Test

With the feed rate dial switch all the way down, move the shaft of the dial back and forth to see if there is a jerky response. Turn the dial and move the shaft back and forth again. Repeat several times. If the jerkiness occurs at the same location on the dial several times, you need to replace the variable speed switch.

## 4.7 Power Feed Preliminary Test

This test will determine if the problem is a mechanical or electrical.

1. Remove the drive belt from the power feed drive pulley.
2. Turn the key switch to the (#2) position. Put the carriage forward/reverse switch into the forward position and turn the feed rate dial through all speeds. If the power feed motor runs properly at all speeds, the problem is a mechanical one instead of an electrical one.

## 4.8 Power Feed Mechanical Test

1. Remove the weight from the track rollers. They should turn smoothly and easily with very little play.
2. Make sure the middle track cover is not bent or touching the top rail.
3. Make sure the middle track oiler is free of sawdust buildup.
4. Make sure the power feed chain is not stiff from rust. Also make sure the chain is not too tight.
5. Check the power feed shaft. Visually inspect the bearings. The shaft should move neither in or out nor side to side.
6. Make sure the power feed chain cam bearing is not touching the main frame tube.
7. Make sure there is no sap or rust on the rails.
8. Make sure the block on the lower track roller assembly is not rubbing the lower rail. Also make sure the track rollers are not too tight.
9. Make sure the power feed belt is properly tightened.

## 4.9 Hydraulic Pressure Test

To check hydraulic pressure:

Operate the loading arm hydraulic lever and read the pressure on the gauge. Hydraulic pressure is factory-set at 2000 ±100 psi and should not need to be readjusted. The relief valve adjustment screw shown may be used to fine-tune the hydraulic pressure.



**CAUTION!** Pressure should not exceed 2000 psi. If it does, the amp draw will rise above the design maximum of 200 amps, and could cause battery and system problems. Pressure above 2000 p.s.i. may also damage the hydraulic hoses.



## SECTION 5 SAWMILL ALIGNMENT

### 5.1 Pre-Alignment Procedures

The Wood-Mizer sawmill is factory aligned. Two alignment procedures are available to realign the sawmill if necessary. The Routine Alignment instructions should be performed as necessary to solve sawing problems not related to blade performance. The Complete Alignment procedure should be performed approximately every 1500 hours of operation (sooner if you regularly transport the sawmill over rough terrain).

#### **Routine Alignment Procedure:**

1. Install and track the blade ([See Section 5.3](#)).
2. Check the angle of the blade in relation to the bed rails and adjust the lower track rollers if necessary ([See Section 5.18](#)).
3. Check and adjust the vertical alignment of the blade guide arm ([See Section 5.7](#)).
4. Check and adjust the horizontal alignment of the blade guide arm ([See Section 5.8](#)).
5. Check and adjust the vertical angle of the blade guides ([See Section 5.11](#)).
6. Check and adjust the horizontal angle of the blade guides ([See Section 5.13](#)).
7. Check and adjust the spacing between the blade guide flanges and the back of the blade ([See Section 5.12](#)).
8. Check and adjust the horizontal angle of the side supports ([See Section 5.15](#)).
9. Check and adjust the vertical angle of the side supports ([See Section 5.16](#)).
10. Check that the blade height scale accurately displays the actual distance from the bottom of the blade to the bed rails and adjust if necessary ([See Section 5.19](#)).

#### **Complete Alignment Procedure:**

Perform all steps in this section to completely realign the sawmill.

## 5.2 Frame Setup

Stationary sawmills should be setup on firm, level ground before proceeding with alignment. Shim the feet so the weight of the sawmill is evenly supported.

Portable sawmills should also be setup on firm, level ground:

**LT40S AH:** Adjust the two middle outriggers on the main frame tube down just enough to lift weight from the trailer tire.

**LT40M AH:** Adjust the two end outriggers on the main frame tube down just enough to lift weight from the trailer tire.

**All Portable Sawmills:** Adjust the two outer outriggers down just so they touch the ground but do not bear weight.

[See SECTION 2 Setup & Operation](#) for additional setup information.

### 5.3 Blade Installation And Alignment

See **Figure 5-1**. Install a blade and apply the appropriate tension ([See Section 2.4](#)). Blade tension is adjusted with the tension handle shown.

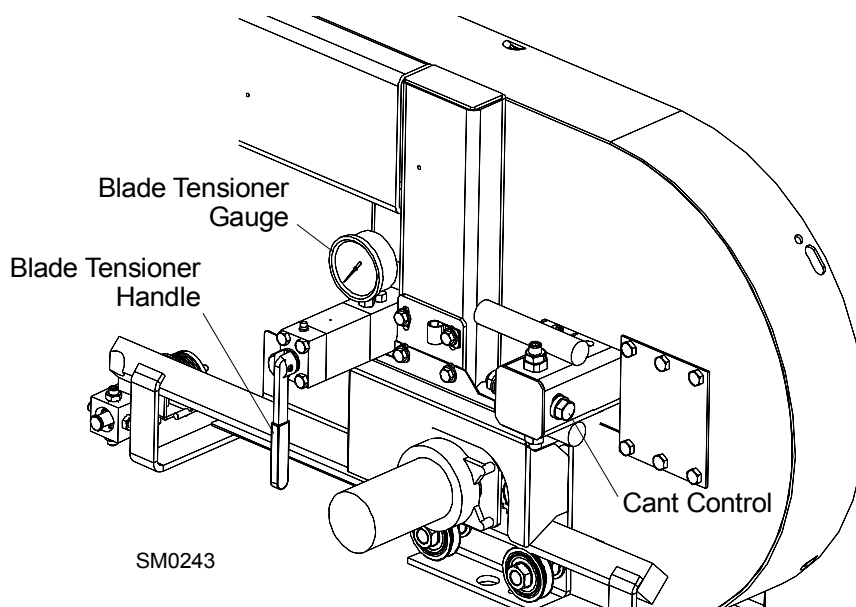

**FIG. 5-1**

1. Raise the middle blade housing cover and make sure all persons are clear of the open side of the saw head.
2. Turn the key switch to pos. #2.
3. Manually spin idle pulley
4. Remove the key and check the position of the blade on the blade wheels.

Check the vertical alignment of the idle-side blade wheel. The gullet of the blade should ride the same distance from the front edge of the wheel at the top and bottom of the wheel. If it does not, loosen and tighten the appropriate adjustment screws on the wheel shaft.

See **Figure 5-2**. The blade wheels should be adjusted so that the gullet of 1 1/4" blades ride 1/8" (3 mm) out from the front edge of the wheels ( $\pm 1/16$  [1.5 mm]). The gullet of 1 1/2" blades should ride 3/16" (4.5 mm) from the front edge of the wheels ( $\pm 1/16$

[1.5 mm]). Do not let the teeth ride on the wheels.

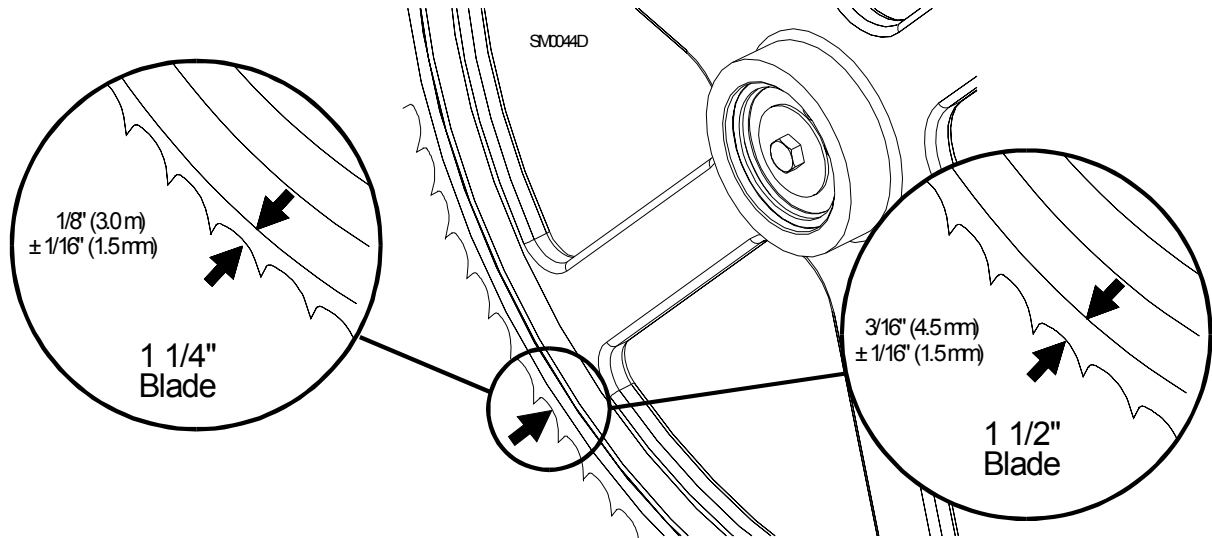

FIG. 5-2

To adjust where the blade travels on the idle-side blade wheel, use the cant control shown in **Figure 5-1**.

If the blade is too far forward on the wheels, turn the cant control counterclockwise. If it is too far back on the wheels, turn the cant control clockwise.

Some adjustment in blade tension may be needed to compensate for adjustments made with the cant control.

Adjustment with the cant control is usually all that is required to track the blade properly on both blade wheels. The drive-side blade wheel will usually not have to be adjusted. If necessary, the drive-side wheel can be adjusted as follows:



## 5 Sawmill Alignment

### Blade Installation And Alignment

**See Figure 5-3.** For horizontal adjustment, use the horizontal adjustment nuts. If the blade is running too far back on the drive-side blade wheel, locate the long U-bolt on the right which mounts the bearing housing to the mounting plates. Loosen the hex nuts on the U-bolt (on the back side of the back plate). Tighten the adjustment nuts to spread the plates apart and bring the blade forward.

If the blade is running too far to the front, loosen the jam nuts on the long U-bolt and back the adjustment bolts out. Tighten the hex nuts on the long U-bolt (on the back side of the back plate).

Be sure to tighten all nuts against the mounting plates when the adjustment is complete.

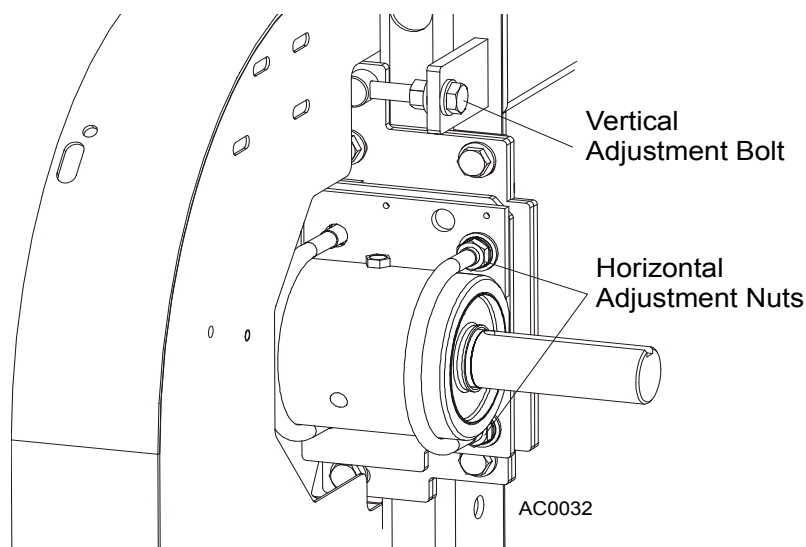

FIG. 5-3

The vertical angle of the drive side wheel is factory-set and should not need to be adjusted. If adjustment is needed, use the vertical adjustment bolt. To tilt the wheel upward, loosen the jam nut and turn the vertical adjustment bolt clockwise. To tilt the wheel downward, loosen the jam nut and turn the vertical adjustment bolt counterclockwise. Be sure to tighten the jam nut.

## 5.4 Saw Head Slide Pad Adjustment

There are eight nylon pads positioned between the saw head frame and vertical mast. The spacing of the pads is factory set and rarely needs adjusting. To check the pad spacing, perform the following steps.

**NOTE:** The pads on the engine side of the mast are referred to as the "inner" pads. The pads on the control side of the mast are referred to as the "outer" pads.

**NOTE:** Shims are often used around the clamping bolts, between the C-frame support bracket and the mast v-brace. The shims align the v-brace to the mast so that the entire face of each slide pad makes contact with the mast. Be sure to keep these shims in place when performing the following adjustment.

See Figure 5-4.

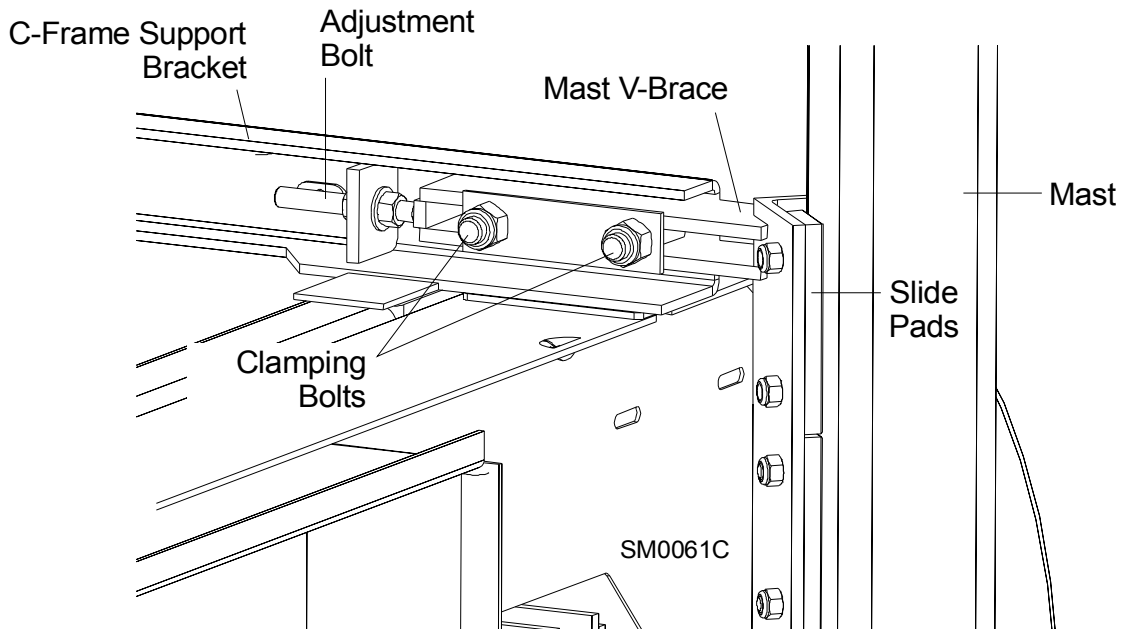

FIG. 5-4

1. Raise the saw head to the top of the vertical mast and secure the saw head with a chain at the top, or shim it underneath. Check the top set of four pads. The outer two pads should be touching the mast rails. There should be a small gap (just wide enough to slide a business card through) between one of the inner pads and the mast rail.



**WARNING!** Always secure the cutting head with a chain or a brace before adjusting the mast pads. The cutting head may fall, causing severe injury or death.

2. To adjust the spacing of the upper set of pads, lower the saw head until you can access the upper slide pad adjustment bolts.
3. Loosen the upper locking bolts and turn the adjusting bolt as necessary to provide the pad spacing described in Step 1.
4. Lower the saw head to the bottom of the vertical mast. Check the bottom set of four pads.

There should be a small gap between one of the outer pads and the mast rail. The gap should be just wide enough to slide a business card through. The inner two pads should be touching the mast rails. To adjust the spacing of the lower set of pads, raise the saw head until you can access the lower slide pad adjustment bolts.

5. Loosen the lower locking bolts and turn the adjusting bolt as necessary to provide the pad spacing described in Step 4.



**CAUTION!** Due to variations in the vertical mast, the pad spacing may vary throughout the travel of the saw head. Check the pad spacing at the top and bottom ends of the mast only. Pads adjusted too tight will cause premature up/down motor failure.

## 5.5 Adjusting The Lower Track Rollers

**See Figure 5-5.** Making these adjustments correctly will give you square cuts and accurate dimensions across the width of your boards.

1. Using the feed controls, move the saw carriage so that the blade is positioned over the front pivot end rail.
2. Check the lower roller on the bottom track rail. Make sure that the bottom rollers touch the bottom rail but remain loose enough that you can turn them with your finger. Use the vertical bolts to adjust the bottom track rollers.
3. Check the inside lower rollers. Both inside rollers should touch the rail so that you cannot spin them by hand. If the rollers are not adjusted evenly and you can spin either one, adjust the horizontal nuts until the roller cannot be spun by hand. Check the other roller and adjust if necessary. Adjust both inside rollers until each evenly supports the carriage and you cannot spin either by hand.
4. Move the carriage forward until the blade is positioned over the rear pivot end rail. Repeat steps 2 & 3 until all lower rollers are adjusted properly at the front and rear of the sawmill.

## 5 Sawmill Alignment

### *Adjusting The Lower Track Rollers*

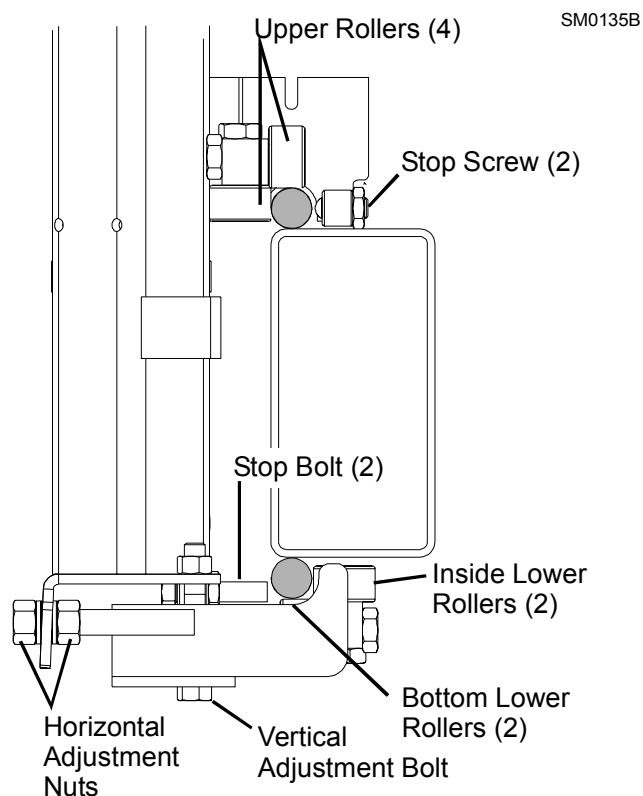

**FIG. 5-5**

5. Remove the blade guides, or adjust them so that they do not touch the blade.
6. Open the adjustable blade guide arm to within 1/2" (15 mm) of full open.
7. Move the carriage back to the front pivot end rail. Raise the cutting head until the bottom of the blade is 17" (400 mm) above the outside of the pivot rail support by actual measurement with a tape or ruler.

See Figure 5-6.

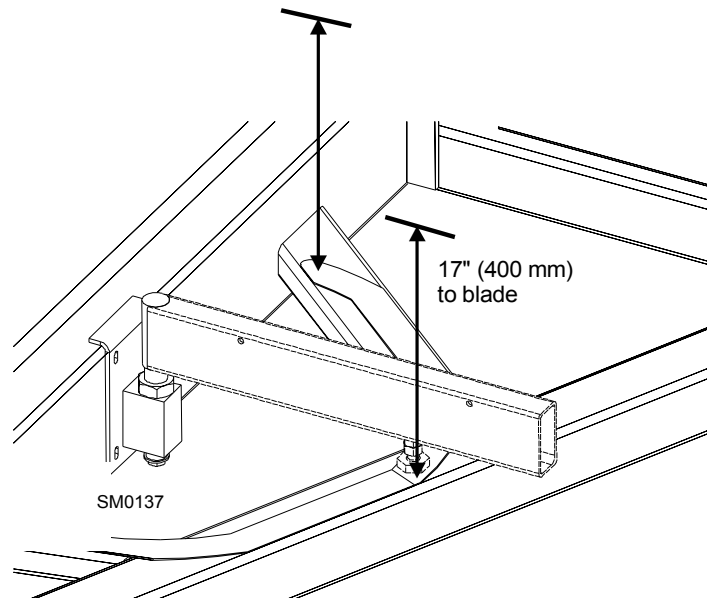

FIG. 5-6

8. Move the carriage forward to check the distance to the blade at the inside of the pivot rail support. All measurements should be equal within  $1/32"$  (0.8 mm).
9. Turn the horizontal adjustment nuts evenly to adjust the inner lower rollers to tilt the saw head until the blade is parallel ( $+1/32"$  [0.8 mm] -0) to the pivot rail support on the outside.

**NOTE:** Adjustments of the lower track rollers change the angle between the cutting head and sawmill bed rails. Only small adjustments of the lower track rollers should ever be needed.

10. After the lower track rollers are adjusted properly, adjust the upper and lower stop screws. Tighten each screw until it just touches the rail. Then, back the screw off  $1/2$  turn. The gap will be approximately  $1/32"$  (0.8mm).



**CAUTION!** It is important that the lower stop bolts are properly adjusted to secure the carriage on the track rail. Failure to properly adjust the stop bolts can cause saw head damage, especially during mill transportation.

## 5.6 Adjusting Bed Rails To The Blade

1. Move the vertical clamp to its lowest position. Before using the clamp tube as a reference to set the blade, make sure it is level.
2. Move the clamp all the way toward the clamp stop. Position the saw head so the blade is over the clamp tube. Measure from the outer end of the clamp tube to the bottom of the blade.
3. Move the saw head back to power the hydraulics and move the clamp all the way out. Position the blade over the clamp tube again and measure from the inner end of the clamp tube to the bottom of the blade.
4. If the clamp tube is level, the measurement to the blade at both ends will be the same within 1/16" (1.5 mm). If adjustment is needed, loosen the four mounting bolts at the outer end of the clamp tube and adjust the clamp tube up or down as necessary. Tighten the mounting bolts.

See Figure 5-7.

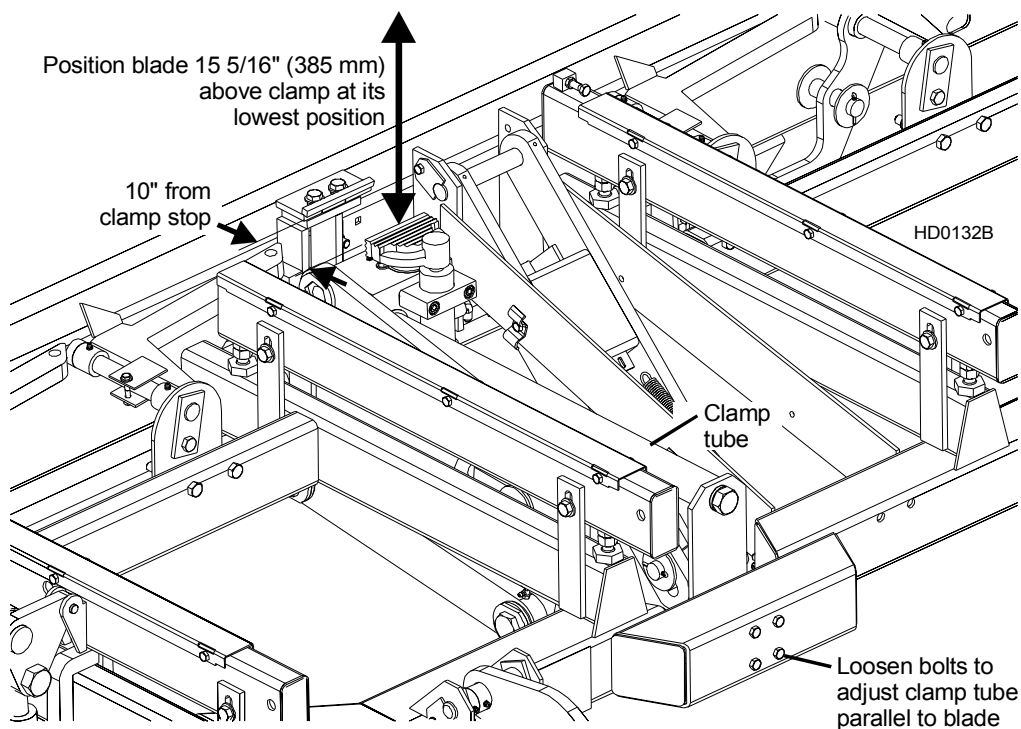

**FIG. 5-7**

5. Move the saw head back to power the hydraulics and move the clamp so it is 10" from the clamp stop. Move the saw head forward until it is positioned over the clamp. Raise the saw head until the blade measures 15 5/16" (385 mm) from the clamp at its lowest position.
6. Adjust the front pivot rail 90° to the main bed tube.
7. Move the saw head to center the blade over the front pivot bed rail.
8. Measure the distance from the top of the pivot rail to the bottom of the blade. Make this measurement at each end of the pivot rail.
9. The two measurements should be 15" (375 mm) (+1/32 [0.8 mm] -0).
10. Loosen the locking set screws and turn the inner height adjustment nut to adjust the height of the inner end of the pivot rail.

**See Figure 5-8.**

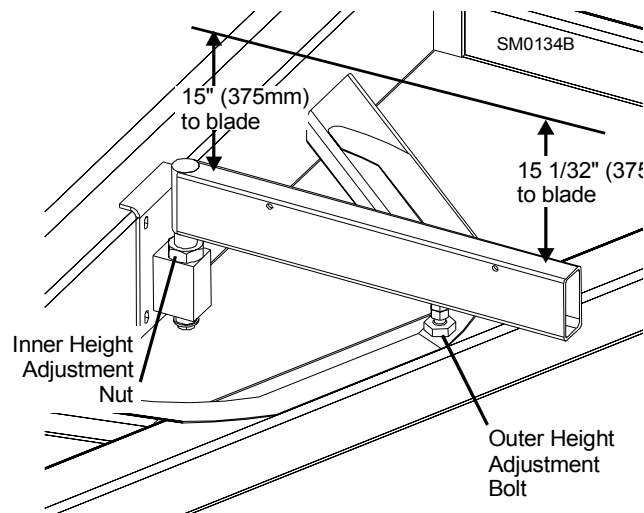

**FIG. 5-8**

11. Loosen the jam nut and turn the outer adjustment bolt to adjust the height of the outer end of the pivot rail.
12. Move the saw head so the blade is positioned over the center of the front main bed rail.
13. Measure the distance between the bottom of the blade and the bed rail at each end of the bed rail. The bed rail should measure 15" (375 mm) (+1/32 [0.8 mm] -0) from the blade at each end of the rail.



## 5 Sawmill Alignment

### Adjusting Bed Rails To The Blade

See Figure 5-9.

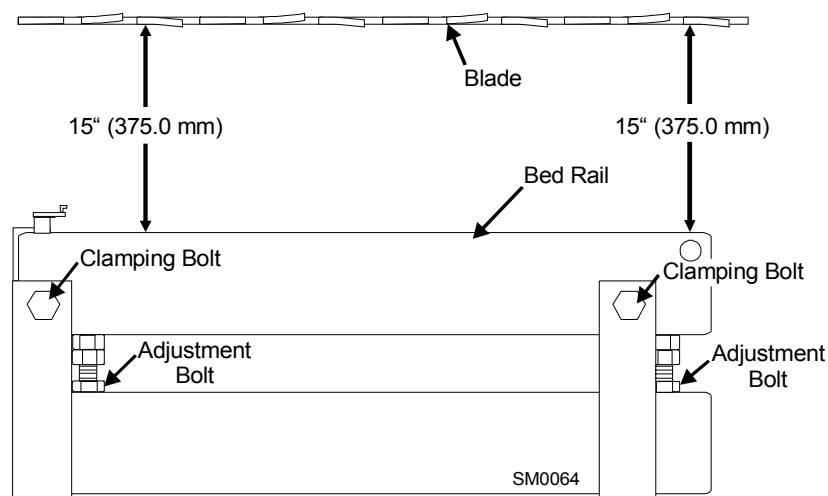

FIG. 5-9

14. Loosen the bed rail clamping bolts and turn the adjustment bolts to move the bed rails to the blade if necessary.
15. Retighten the clamping bolts and adjustment bolts.
16. Without adjusting the saw head height, check the three remaining main bed rails and the rear pivot rail. Adjust them so that all measure the same distance from the blade at both ends of the bed rail.

## 5.7 Blade Guide Arm Vertical Adjustment

1. Move the saw head so that the blade guide arm is directly over a bed rail.
2. Adjust the blade guide arm out to within 1/2" (15 mm) of full open.
3. Measure from the top of the bed rail to the arm.

See Figure 5-10.

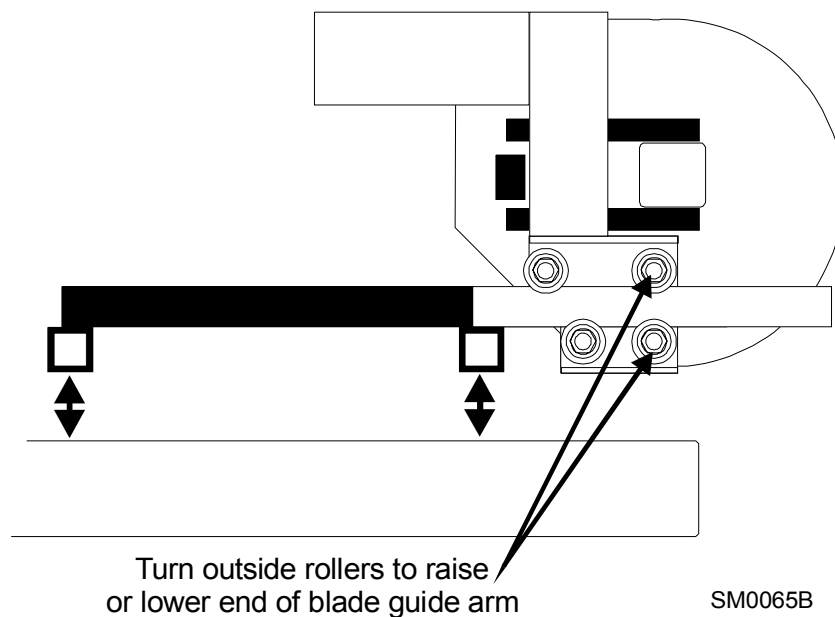

FIG. 5-10

4. Adjust the blade guide arm in to within 1/2" (15 mm) of full closed. Measure again from the top of the bed rail to the arm.
5. Adjust the arm so that the measurement from the top of the bed rail to the arm in the closed position is the same as the measurement from the top of the bed rail to the arm in the open position.

If the arm is too low in the closed position, loosen the lower outside roller and tighten the upper outside roller (See Step 6.)

If the arm is too high in the closed position, loosen the upper outside roller and tighten the lower outside roller (See Step 6.)

6. The rollers are mounted on cam bolts that raise or lower the arm when turned.

To adjust the rollers, locate the cam bolt head inside the housing and turn until the arm is lowered or raised as needed. Recheck the arm in both the open and closed positions. Repeat adjustments until the arm is the same distance from the bed rail in the open and closed position.

7. The blade guide arm should be snug, but not too tight, in the rollers. You should be able to move it in and out with firm hand pressure. There should be no side-to-side play.

## 5.8 Blade Guide Arm Horizontal Adjustment

1. Put the blade guide assembly back in the arm (if you took it out). Put the assembly back so that the flanged collar on the roller is about 1/8" (3.0 mm) from the back of the blade when the throat is 1/2" (15 mm) from full open.
2. Close the throat to within 1/2" (15 mm) from fully closed. Check to see that the flange is the same distance from the back of the blade.

See Figure 5-11.

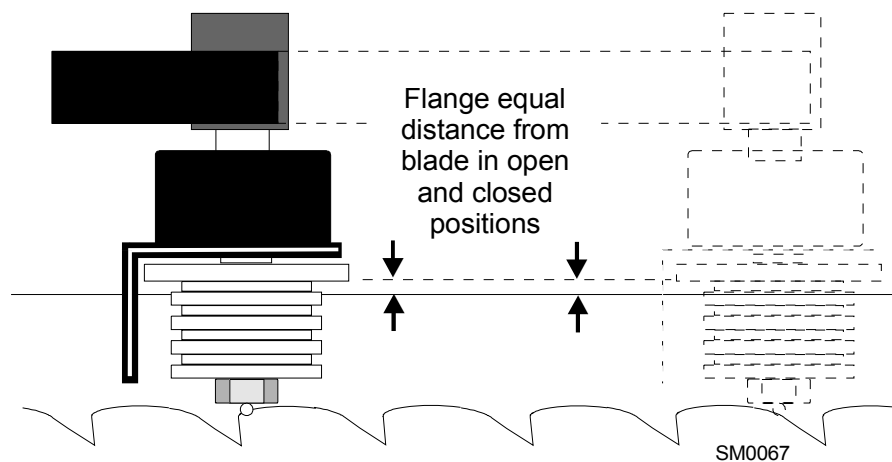

FIG. 5-11

## 5 Sawmill Alignment

### Blade Guide Arm Horizontal Adjustment

3. If adjustment is needed, the guide rollers can be adjusted in or out on the threaded mounts to open or close the gap.

See Figure 5-12.

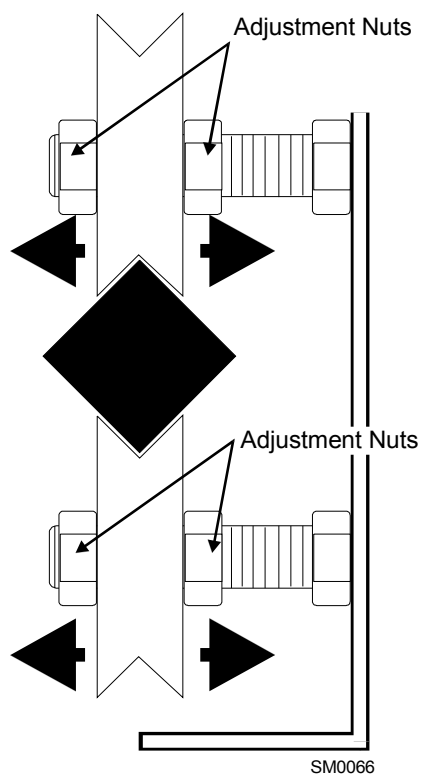

FIG. 5-12

4. Adjusting the outside two rollers (furthest from the arm motor) inward will cause the flange to move away from the blade.
5. Adjusting the two outside rollers outward will cause the flange to move toward the blade.
6. Adjust until the roller flange is the same distance from the back of the blade in the open and closed position.

## 5.9 Aligning the Blade Guides

Each Wood-Mizer sawmill has two blade guide assemblies that help the blade maintain a straight cut. The two blade guide assemblies are positioned on the saw head to guide the blade on each side of the material being cut.

One blade guide assembly is mounted in a stationary position on the drive side of the saw head. This assembly is referred to as the "inner" blade guide assembly.

The other blade guide assembly is mounted on the idle side of the saw head. It is referred to as the "outer" assembly and is adjustable for various widths of materials to be processed.

Blade guide alignment includes four steps:

- Blade Deflection
- Blade Guide Vertical Tilt
- Blade Guide Flange Spacing
- Blade Guide Horizontal Tilt

Perform the blade guide alignment after you have aligned the blade on the wheels and adjusted the blade and blade guide arm parallel to the bed rails. After blade guide alignment, check the scale indicator to make sure it is adjusted properly ([See Section 5.19](#)).

**NOTE:** During blade guide alignment, remove the blade guide adjusting screws and apply a lubricating oil such as 10W30 or Dexron III to each screw. This will prevent the screws and threaded holes from corroding and make screw adjustments easier.

## 5.10 Blade Deflection

Perform the following steps to achieve proper blade deflection with the blade guides.

1. Raise the carriage until the blade is 15" (375 mm) above a bed rail. Measure the actual distance with a tape from the top of the rail to the bottom of the blade.
2. Install the blade guides. Make sure the two set screws shown are threaded into the blade guide shaft until they touch each other.

See Figure 5-13.

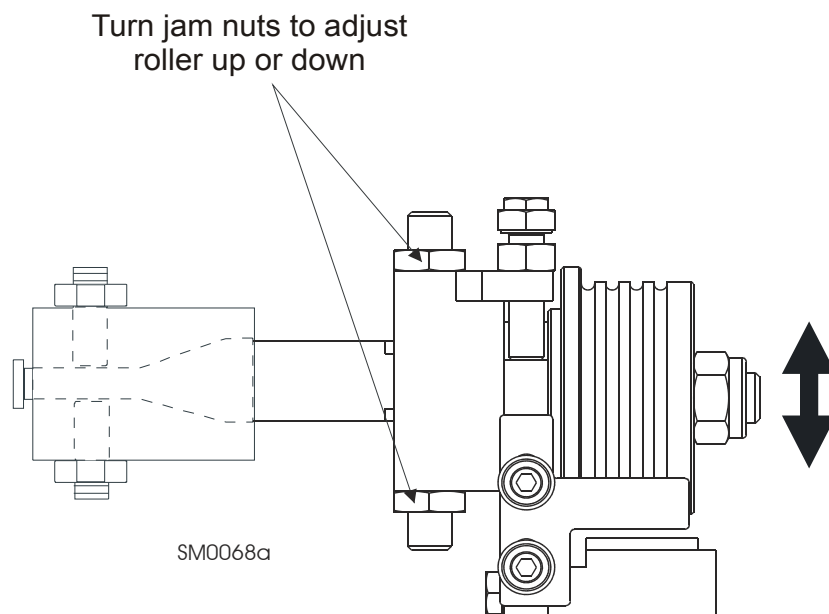

FIG. 5-13

3. Loosen the bottom jam nut and tighten the top jam nut until the blade guide deflects the blade down 1/4" (6.5 mm).
4. Repeat for the other blade guide.

**NOTE:** Be sure that the blade guide deflector rod clears the blade on both guide assemblies. The rod on the outer guide assembly should be checked with the arm all the way in and all the way out.

## 5.11 Blade Guide Vertical Tilt Adjustment

Check that the blade guide does not tilt the blade up or down. A Blade Guide Alignment Tool (BGAT) is provided to help you measure the vertical tilt of the blade.

1. Open the adjustable blade guide arm 1/2" (15 mm) from full open.
2. Clamp the alignment tool on the blade. Position the tool close to a blade guide roller. Be sure the tool does not rest on a tooth or burr, and is lying flat on the blade.

See Figure 5-14.

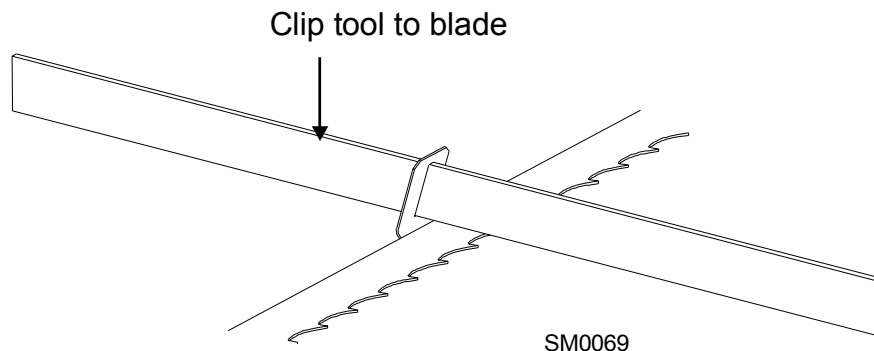

FIG. 5-14

3. Measure the distance from the bed rail to the bottom of the tool.

**NOTE:** If the sawmill is equipped with stainless steel bed rail covers, be sure to measure from the blade guide alignment tool to the top surface of the cover rather than the bed rail tube.

4. Move the carriage so that the front end of the tool is positioned above the bed rail.
5. Measure the distance from the bed rail to the bottom edge of the tool.
6. Loosen one set screw at the side of the blade guide assembly.
7. Use the set screws shown to tilt the blade guide until the measurement from the bed rail to the tool equals the first measurement taken at the center of the tool.



## 5 Sawmill Alignment

### Blade Guide Vertical Tilt Adjustment

See Figure 5-15.

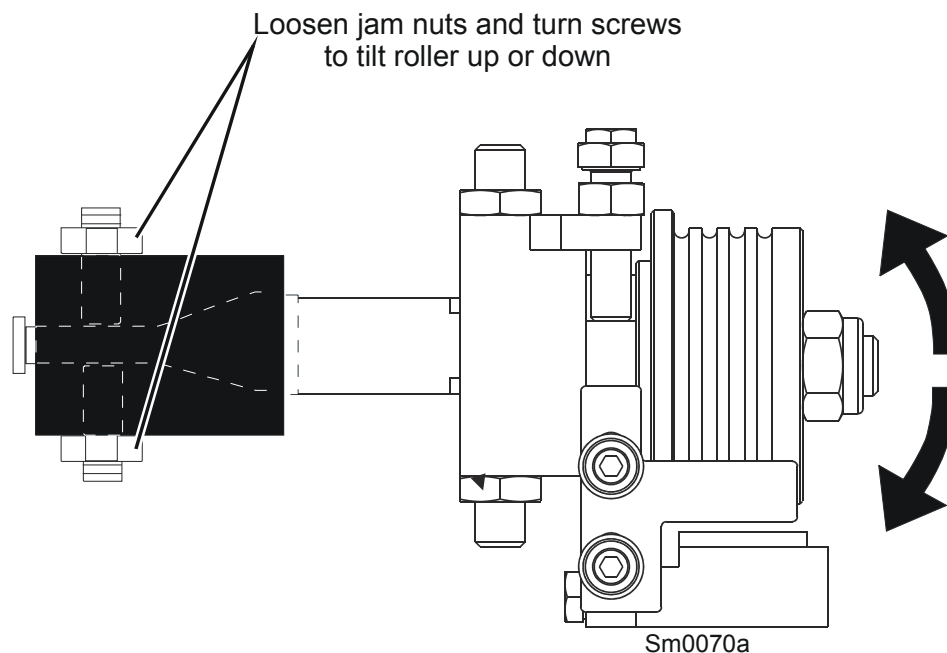

FIG. 5-15

8. Move the carriage forward so the back end of the tool is over the bed rail.
9. Use the set screws shown to adjust the blade guide tilt until the measurement from the bed rail to the tool equals the other two measurements taken.
10. Move the tool close to the other blade guide and repeat the previous steps.

**NOTE:** If major adjustments to blade guide tilt were made, measure the distance between the blade and the bed rails again to ensure the correct 1/4" (6.5 mm) blade guide deflection. Adjust if necessary.

## 5.12 Blade Guide Spacing

**HINT:** When adjusting blade guide spacing, loosen the top set screw and one side set screw only. This will ensure horizontal and vertical tilt adjustments are maintained when the set screws are retightened.

1. Adjust the inner blade guide so the blade guide flange is approximately 1/16"-1/8" (1.5-3.0 mm) from the back of the blade.
2. Loosen one side and one top set screw shown. Tap the blade guide forward or backward until properly positioned.

See Figure 5-16.

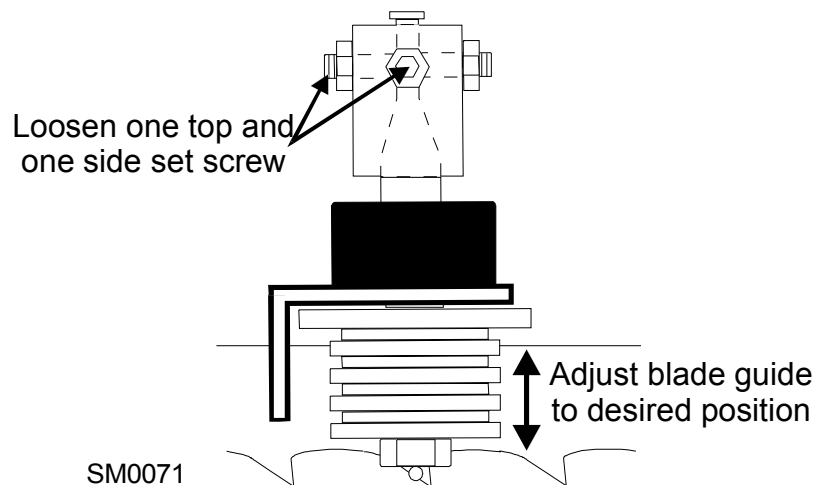

FIG. 5-16

3. Retighten the two set screws.
4. Adjust the outer blade guide in the same way so the blade guide flange is approximately 1/16"-1/8" (1.5-3.0 mm) from the back of the blade.

### 5.13 Horizontal Tilt Adjustment

1. Finally, both blade guides must be tilted horizontally. Adjust the blade guide arm halfway in.

See Figure 5-17.

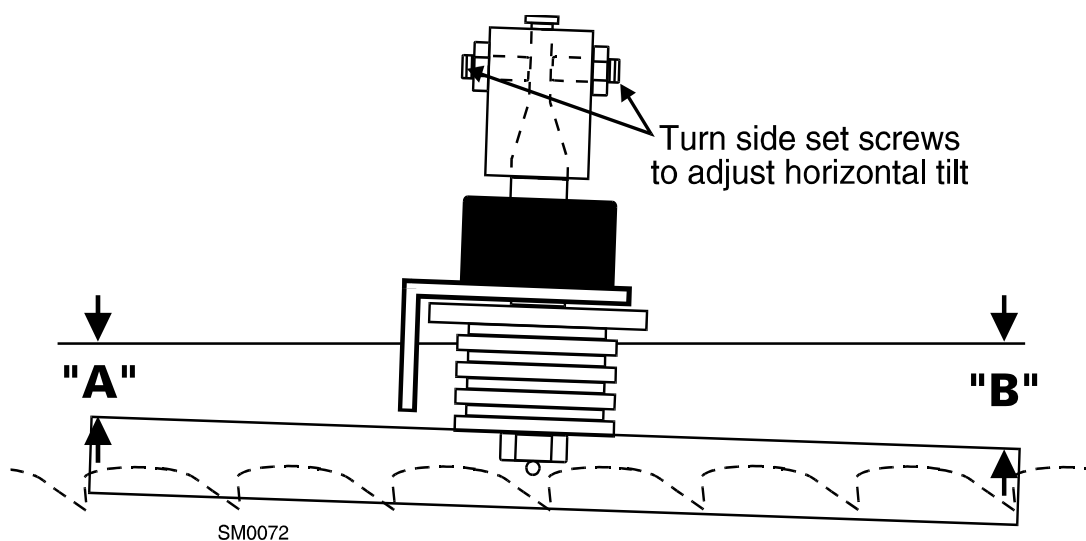

FIG. 5-17

2. Place the Blade Guide Alignment Tool against the face of the outer blade guide roller.
3. Center the tool on the roller and measure between the back edge of the blade and the ruler at the end closest to the inner blade guide ("B").
4. Measure between the back edge of the blade and the other end of the ruler ("A").
5. The roller should be parallel to the blade ( $A=B$ ) or tilted slightly to the left ( $A=B-1.4$ " [6 mm]).
6. Use the side set screws to adjust the horizontal tilt of the roller.
7. Repeat steps 3-7 for the inner blade guide roller.

**NOTE:** Once the blade guides have been adjusted, any cutting variances are most likely caused by the blade. **See the Blade Handbook, Form #600.**

## 5.14 Blade Guide Disc Adjustment

To ensure correct cutting, adjust the gap between the blade guide disc and the blade. Perform the adjustment with the blade installed and properly tensioned.

**See Figure 5-18.** Loosen both nuts and retaining bolts. Use the adjustment bolt to raise or lower the disc until its distance from the blade is .2 - .025 mm. Then retighten the retaining bolts so that the disc is parallel to the blade. Retighten the retaining bolt nuts.

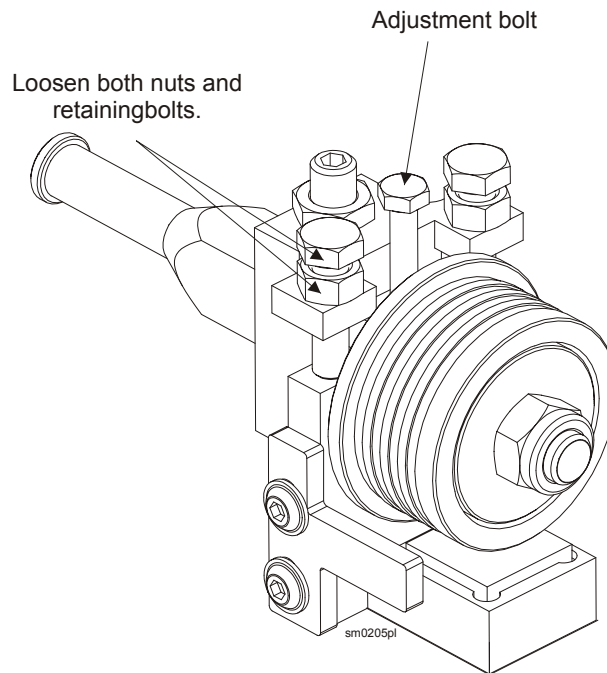

**FIG. 5-18**

# 5 Sawmill Alignment

## Blade Guide Disc Adjustment

---

See Figure 5-19. The gap between the disc and the blade should measure .2 - .25 mm.

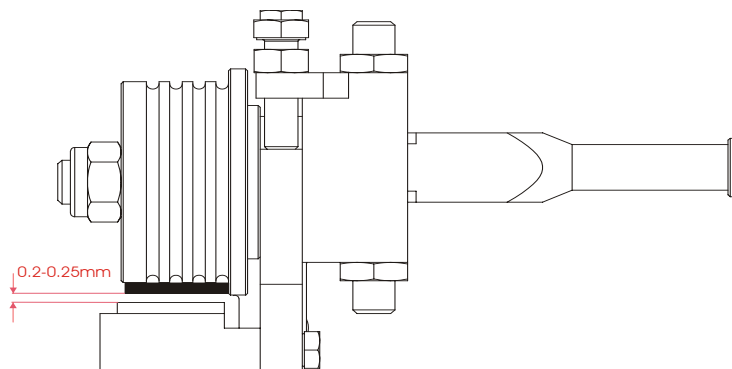

**FIG. 5-19**

## 5.15 Horizontal Adjustment of Side Supports

Logs and boards are clamped against the side supports when sawing. The side supports must be square to the bed to ensure square lumber.

1. Swing the side support down.
2. Measure between the face of the support and the main bed tube. Make measurements at both ends of the side support to make sure that it is parallel to the rail.

See Figure 5-20.

3. Use the two lower bolts to adjust the side support so  $B=A$  or  $+1/32"$  (0.8 mm).
4. Repeat for remaining side supports.

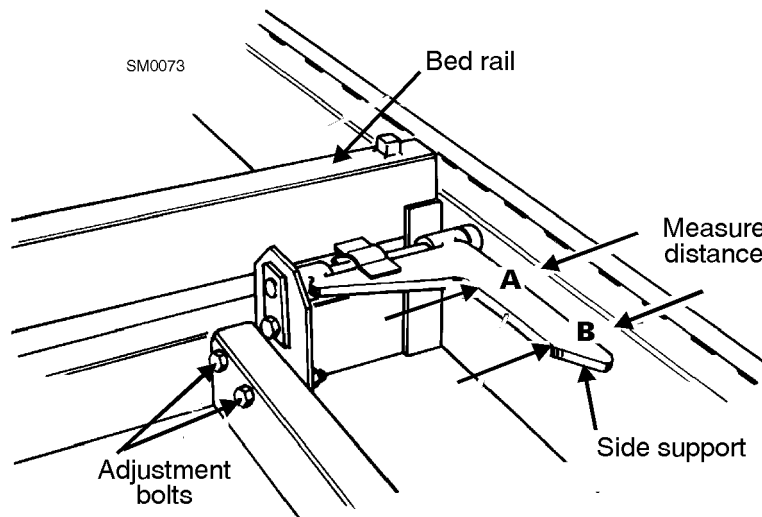

FIG. 5-20

## 5.16 Vertical Adjustment of Side Supports

1. Place a flat board across the bed rails.
2. Swing a side support up so that it is vertical.
3. Pull back at the top of the support to eliminate slack as if a log were being clamped against it.

See Figure 5-21.

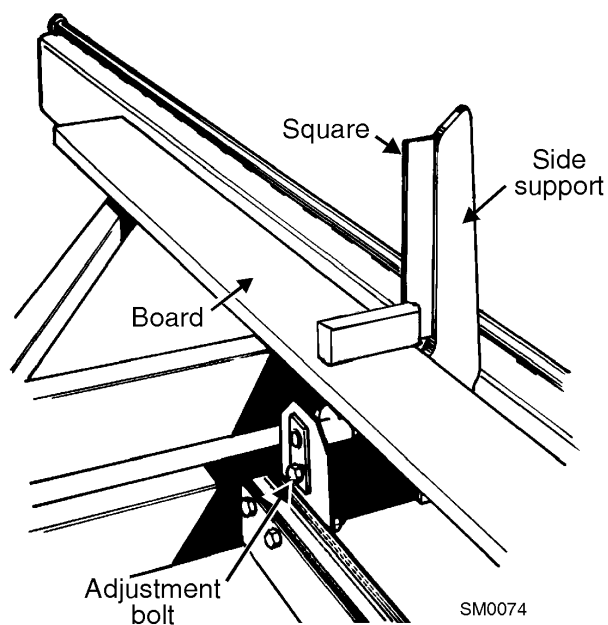

FIG. 5-21

4. Check the angle of each support with a square on the board.
5. The side support should be 90° to the bed rails or leaning forward 1/32" (0.8 mm). Loosen the top adjustment bolt, adjust the side support, and retighten the bolt.
6. Repeat for the remaining side supports.

## 5.17 Clamp Stop/Stop Bolt Adjustment

1. Once the side supports are aligned, pivot them down to their horizontal position.
2. Tie a string across the face of the side supports.

See Figure 5-22.

3. Loosen the clamp stop bolts and adjust the clamp stop until it touches the string. Loosen the jam nut and adjust the bolt on the middle-rear bed rail until it touches the string.

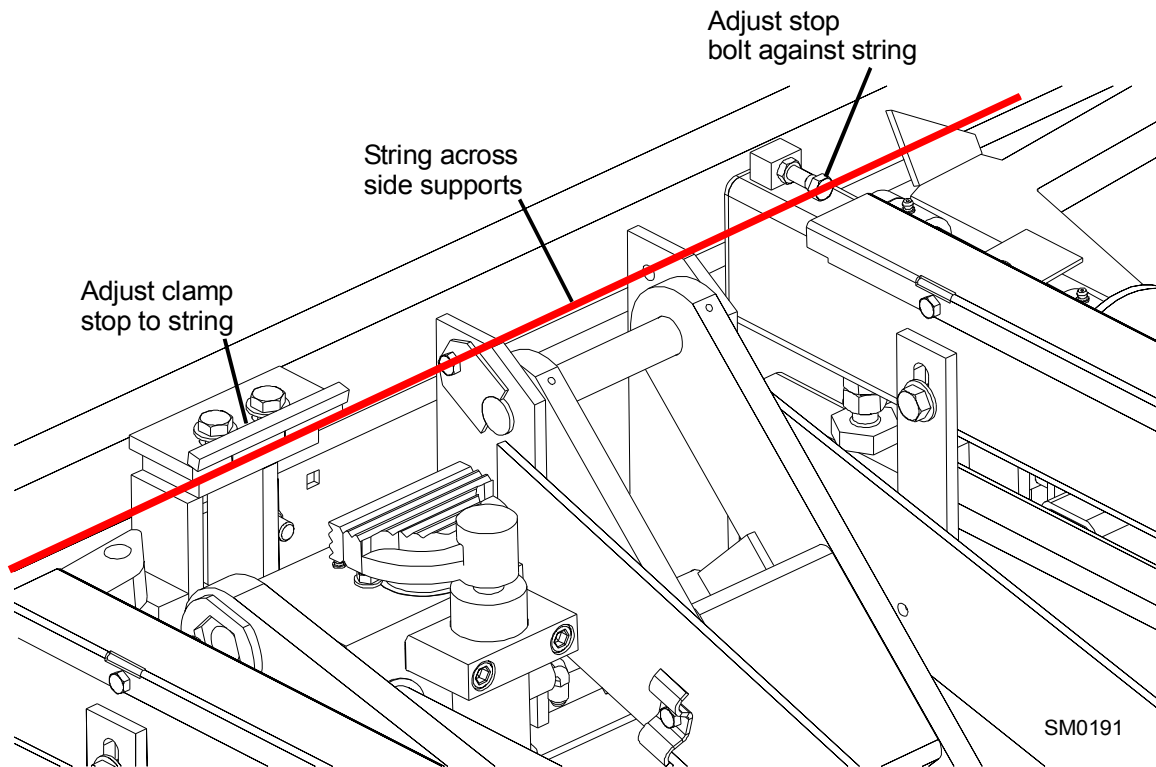

FIG. 5-22



### 5.18 Saw Head Tilt

As the blade enters a wide log or cant, the outside of the saw head will drop down slightly. To compensate for the drop, use the lower track roller horizontal bolts to raise the outside of the saw head 1/16" (1.5 mm).

1. Move the saw head so the blade is positioned 14 3/4" (375 mm) above a bed rail.
2. Adjust the lower track roller horizontal nuts until the blade measures 14 13/16" (376.5 mm) from the bed rail near the outer blade guide.

See Figure 5-23.

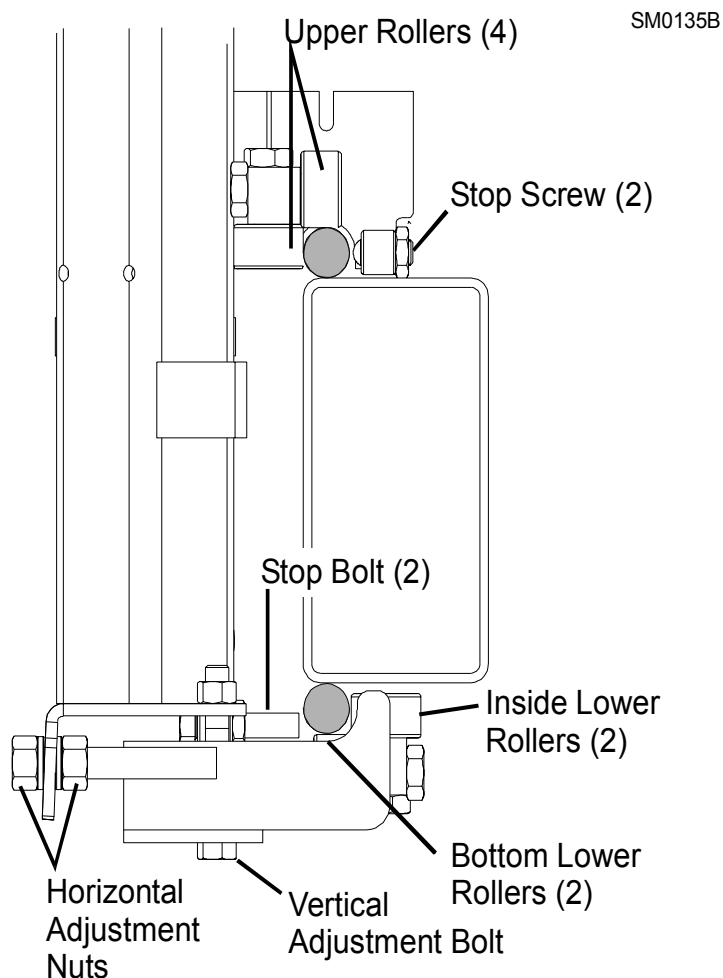

FIG. 5-23

## 5.19 Blade Height Scale Adjustment

After the entire sawmill has been aligned and all adjustments made, check that the blade height scale indicates the true distance from the blade to the bed rails.

1. Move the saw head so the blade is positioned directly above one of the bed rails. Measure from the bottom edge on a down-set tooth of the blade to the top of the bed rail (or stainless steel sleeve if applicable).

See Figure 5-24.

2. View the blade height scale with eyes level with the indicator.

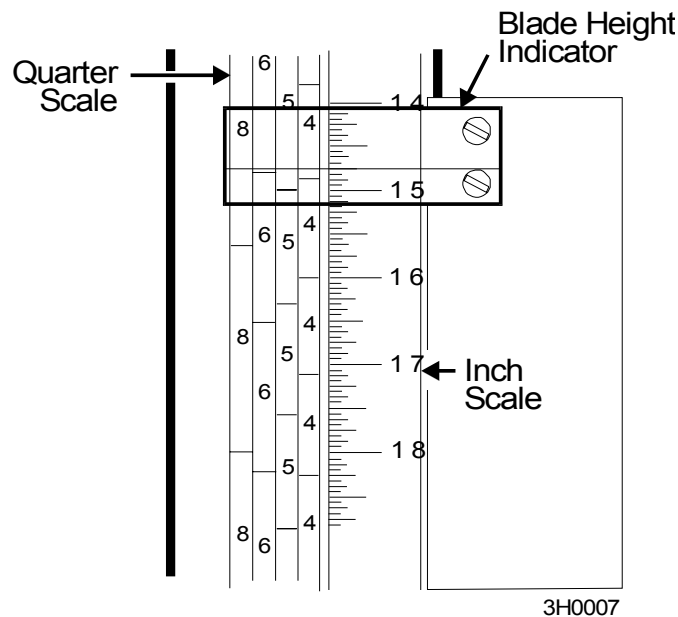

FIG. 5-24

3. Loosen the indicator bracket mounting bolts and adjust the bracket until the indicator is aligned with the correct mark on the scale (+0 -1/32 [0.8 mm]). Retighten the bracket mounting nut.

For example, if the measurement from blade to bed rail was 14 3/4" (375 mm), make sure the indicator reads 14 3/4" (375 mm) on the scale.

## 5.20 Board Return Bracket

Adjust the board return bracket so the bottom edge is positioned 1/4" below the bottom of the blade.

1. With a square cant on the bed rails, lower the blade until it touches the top of the cant. Then raise the saw head 1/4" as shown on the scale.
2. Lower the board return arm. The board return bracket should barely touch the top of the cant.
3. Loosen the three bracket mounting bolts to adjust the bracket up or down as necessary.

See Figure 5-25.

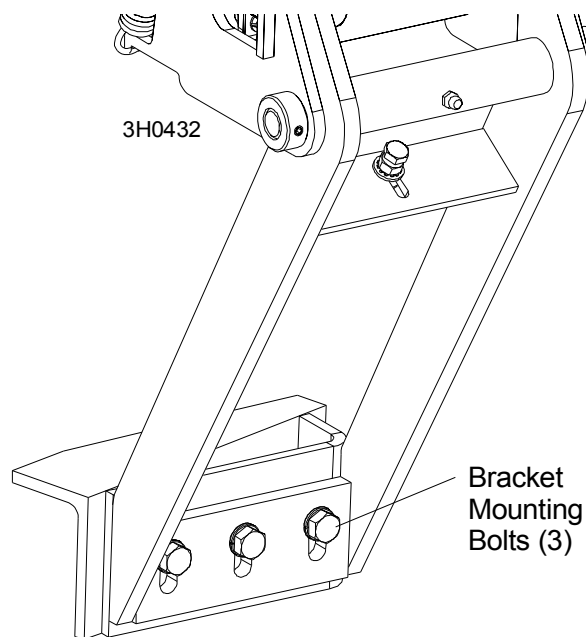

FIG. 5-25