

user manual

Instrukcja obsługi | Руководство пользователя
Manuel de l'Utilisateur | Betriebsanweisung
Bruksanvisning | Manual del Usuario
Betjeningsvejledning | Gebruikershandleiding
Käyttöohjeet | Manual de utilizare | Bruksanvisning
Manuale d'uso | Příručka uživatele

Zachować do przyszłego użytku
Сохраните для последующего использования
A conserver pour une utilisation future
Für zukünftige Benutzung aufbewahren
Behold for senere bruk
Säilytä nämä käyttöohjeet tulevaa tarvetta marten
Opbevar manualen til fremtidig brug
Bewaren voor gebruik in de toekomst
Conservare il presente manuale a l'uso futuro
Păstrați acest manual pentru utilizare viitoare
Conservar para futuras consultas
Uchovejte pro další použití

Twin Vertical Saw TVS

Safety, Operation, Maintenance & Parts Manual

**TVSE11S
TVSE15S**

**rev.A7.00
rev.A7.00**



Safety is our #1 concern! Read and understand all safety information and instructions before operating, setting up or maintaining this machine.

January 2007

Form #1001

**This is the original language
for the manual**

Table of Contents

Section-Page

SECTION 1	SAFETY	1-1
1.1	Safety Symbols.....	1-1
1.2	Safety Instructions.....	1-2
SECTION 2	OPERATION	2-1
2.1	General Information.....	2-1
2.2	Control Overview.....	2-3
2.3	TVS Setup.....	2-6
2.4	Replacing The Blades.....	2-8
2.5	Tensioning The Blades.....	2-9
2.6	Tracking The Blade.....	2-10
2.7	Machine Start.....	2-11
2.8	Cutting Width Setting.....	2-15
2.10	Operation Procedure.....	2-18
2.11	Loading Ramp Operation.....	2-20
2.12	Cross Transfer Deck Operation.....	2-21
SECTION 3	SETWORKS OPERATION (OPTIONAL EQUIPMENT)	3-1
3.1	TVS Controller Panel.....	3-1
3.2	Start-up Settings of the Controller.....	3-3
3.3	Operation, Memory Buttons (A, B, C, D, E).....	3-5
SECTION 4	TROUBLESHOOTING	4-1
4.1	Setworks Malfunction.....	4-1
SECTION 5	MAINTENANCE	5-1
5.1	Wear Life.....	5-1
5.2	Blade Guides.....	5-1
5.3	Sawdust Removal.....	5-1
5.4	Miscellaneous Lubrication.....	5-3
5.5	Belts.....	5-4
5.6	Drive Belt Adjustment.....	5-4
5.7	Feed Track Chain Tension.....	5-7
5.8	Log Deck and Transfer Deck Drive Chain Tension.....	5-10
5.9	Lube Mizer System.....	5-11
5.10	Safety Devices Inspection.....	5-12
SECTION 6	ALIGNMENT	6-1
6.1	Routine Alignment Procedure.....	6-1
6.2	Complete Alignment Procedure.....	6-12
SECTION 7	SPECIFICATIONS	7-1
7.1	Overall Dimensions.....	7-1
7.2	Cutting Capacity.....	7-4
7.3	Blade Motor Specifications.....	7-5

Table of Contents

Section-Page

7.4	Electrical Diagram, TVS EB15	7-6
7.5	Electrical Diagram, TVS EB15S	7-8
7.6	Electrical Component List, TVS EB15S	7-10
7.7	Electrical Diagram, TVS EC15	7-11
7.8	Electrical Component List, TVS EC15S	7-13
7.9	Electrical Diagram, TVS EH11	7-14
7.10	Electrical Diagram, TVS EH11S	7-16
7.11	Electrical Diagram, TVS EH15	7-18
7.12	Electrical Diagram, TVS EH15S	7-20
7.14	Dust Extractor Specifications	7-23
SECTION 8 DC ELECTROMAGNETIC BRAKE		8-1
8.1	Design and Principle of Operation	8-1
8.2	Service	8-2

SECTION 1 SAFETY

1.1 Safety Symbols

The following symbols and signal words call your attention to instructions concerning your personal safety. Be sure to observe and follow these instructions.



DANGER! indicates an imminently hazardous situation which, if not avoided, will result in death or serious injury.



WARNING! suggests a potentially hazardous situation which, if not avoided, could result in death or serious injury.



CAUTION! refers to potentially hazardous situations which, if not avoided, may result in minor or moderate injury or damage to equipment.



IMPORTANT! indicates vital information.

NOTE: gives helpful information.



Warning stripes are placed on areas where a single decal would be insufficient. To avoid serious injury, keep out of the path of any equipment marked with warning stripes.

1.2 Safety Instructions



IMPORTANT! The sawmill is intended for sawing wood only. [See Section 5.2](#) for log size capacities of the machine.

IMPORTANT! The operator of the sawmill should get adequate training in the operation and adjustment of the machine.

NOTE: ONLY safety instructions regarding personal injury are listed in this section. Caution statements regarding only equipment damage appear where applicable throughout the manual.

Observe Safety Instructions



IMPORTANT! Read the entire Operator's Manual before operating the machine. Take notice of all safety warnings throughout this manual and those posted on the machine. Keep this manual with this machine at all times, regardless of ownership.

Also read any additional manufacturer's manuals and observe any applicable safety instructions including dangers, warnings, and cautions.

Only persons who have read and understood the entire operator's manual should operate the machine. The machine is not intended for use by or around children.

IMPORTANT! It is always the owner's responsibility to comply with all applicable national and local laws, rules and regulations regarding the ownership and operation of your Wood-Mizer Twin Vertical Saw. All Wood-Mizer TVS/SVS owners are encouraged to become thoroughly familiar with these applicable laws and comply with them fully while using the machine.



Wear Safety Clothing



WARNING! Secure all loose clothing and jewelry before operating the machine. Failure to do so may result in serious injury or death.

WARNING! Always wear gloves and eye protection when handling bandsaw blades. Changing blades is safest when done by one person! Keep all other persons away from area when coiling, carrying or changing a blade. Failure to do so may result in serious injury.

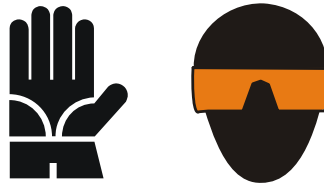

WARNING! Always wear eye, ear, respiration, and foot protection when operating or servicing the machine.



Keep the Machine And Area Around Clean



DANGER! Maintain a clean and clear path for all necessary movement around the machine and lumber stacking areas. Failure to do so will result in serious injury.

Dispose Of Sawing By-Products Properly



IMPORTANT! Always properly dispose of all sawing by-products, including sawdust and other debris.

CAUTION! The machine work-stand should be equipped with a 4 kg / 8.818 lb or bigger dry powder extinguisher.

Check the Machine Before Operation



DANGER! Make sure all guards and covers are in place and secured before operating the machine. Failure to do so may result in serious injury.



WARNING! Fasten the machine to the floor before operating.

IMPORTANT! The machine's operator should get training in operation and adjustment of the machine.



Keep Persons Away



DANGER! Keep all persons out of the path of moving equipment and lumber when operating the machine. Failure to do so will result in serious injury.

DANGER! Always be sure all persons are out of the path of the blade before starting the motor. Failure to do so will result in serious injury.



WARNING! Allow blade to come to a complete stop before opening the blade housing cover. Failure to do so will result in serious injury.

Keep Hands Away



DANGER! Always shut off the blade motor before changing the blade. Failure to do so will result in serious injury.

DANGER! Motor components can become very hot during operation. Avoid contact with any part of a hot motor. Contact with hot motor components can cause serious burns. Therefore, never touch or perform service functions on a hot motor. Allow the motor to cool sufficiently before beginning any service function.

DANGER! Always keep hands away from moving bandsaw blade. Failure to do so will result in serious injury.

DANGER! Always be aware of and take proper protective measures against rotating shafts, pulleys, fans, etc. Always stay a safe distance from rotating members and make sure that loose clothing or long hair does not engage rotating members resulting in possible injury.



WARNING! Use extreme caution when spinning the blade wheels by hand. Make sure hands are clear of blade and wheel spokes before spinning. Failure to do so may result in serious injury.

CAUTION! Before installation of the blade, inspect it for damage and cracks. Use only properly sharpened blades. Always handle the blade with extreme caution. Use suitable carrier equipment for transporting blades.

Use Proper Maintenance Procedures



DANGER! Make sure all electrical installation, service and/or maintenance work is performed by a qualified electrician and is in accordance with applicable electrical codes.

DANGER! Hazardous voltage inside the electric boxes and at the motor can cause shock, burns, or death. Disconnect and lock out power supply before servicing! Keep all electrical component covers closed and securely fastened during machine operation.



WARNING! Consider all electrical circuits energized and dangerous.

WARNING! Disconnect and lock out power supply before servicing! Failure to do so may result in serious injury.

WARNING! Never assume or take the word of another person that the power is off; check it out and lock it out.

WARNING! Do not wear rings, watches, or other jewelry while working around an open electrical circuit.

WARNING! Remove the blade before performing any service to the motor. Failure to do so may result in serious injury.



DANGER! The operator must not for any reason perform any laser maintenance or repair work.

DANGER! Never clean the blade or the blade wheels using a brush or a scraper whilst the blade is in motion.

CAUTION! Before installation of the blade, inspect it for damage and cracks. Use only properly sharpened blades. Always handle the blade with extreme caution. Use suitable carrier equipment for transporting the blades.



IMPORTANT! No exchange with a different type of laser is permitted, that no additional optical equipment shall be used.

Keep Safety Labels In Good Condition



IMPORTANT! Always be sure that all safety decals are clean and readable. Replace all damaged safety decals to prevent personal injury or damage to the equipment. Contact your local distributor, or call your Customer Service Representative to order more decals.

IMPORTANT! If replacing a component which has a safety decal affixed to it, make sure the new component also has the safety decal affixed.

Fire-Fighting

CAUTION! The machine’s work-stand should be equipped with a 4 kg / 8.818 lb or bigger dry powder extinguisher.

Safety Labels Description

See Table 1-1. Pictogram decals used to warn and inform the user about danger in the saw.

TABLE 1-1



Decals View	Decal No.	Description
	096317	Carefully read the operator’s manual before operating the machine. Observe all safety instructions and rules when operating.
	099220	Close all guards prior to operating the machine
	099219	Blade tension adjustment. Turn right to tighten; turn left to release.

TABLE 1-1

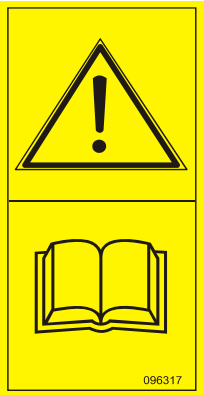

 <p>099221</p>	<p>099221</p>	<p>Keep all persons at a safe distance from work area when operating the machine.</p>
 <p>096314</p>	<p>096314</p>	<p>Keep all persons at a safe distance from work area when operating the machine.</p>
 <p>096316</p>	<p>096316</p>	<p>Opening of the electric box is possible only when the switch is in the "0" position.</p>

TABLE 1-1

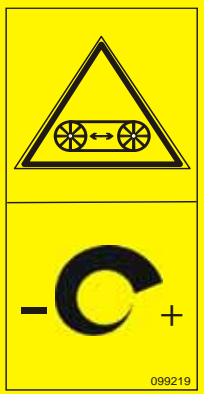





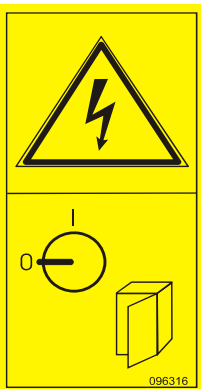

	<p>096319</p>	<p>Always disconnect the power cord before opening the electric box.</p>
	<p>098177</p>	<p>Always disconnect the power cord before performing any service.</p>
	<p>099540</p>	<p>CAUTION! Gear train - Keep a safe distance!</p>
	<p>096321</p>	<p>Blade movement direction</p>

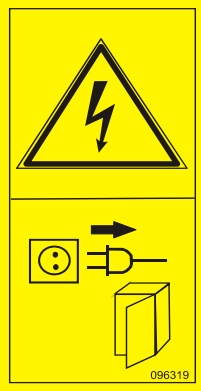
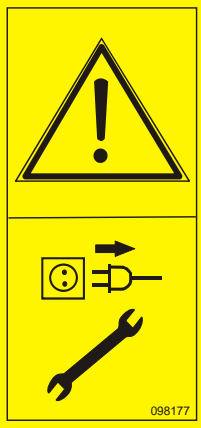
TABLE 1-1

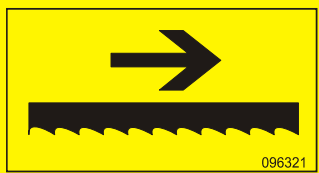
	<p>500031</p>	<p>CAUTION! Do not adjust the turnbuckles!</p>
	<p>S12004G</p>	<p>Always wear eye protection equipment when operating this machine.</p>
	<p>S12005G</p>	<p>Always wear ear protection equipment when operating this machine.</p>
	<p>501465</p>	<p>CAUTION! Always wear safety boots when operating this machine.</p>
	<p>501467</p>	<p>Lubrication point</p>

1 SAFETY

Safety Labels Description

TABLE 1-1







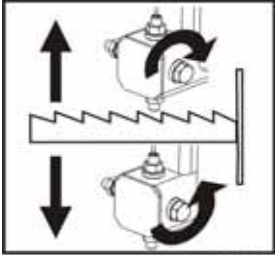
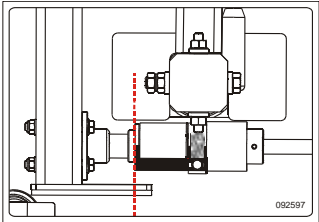

 <p>P11789b</p>	<p>P11789</p>	<p>Blade alignment. Turn right to move the blade out on the wheel; turn left to move the blade in on the wheel.</p>
 <p>092597</p>	<p>092597</p>	<p>Blade tension adjustment (See Section 2.5)</p>
	<p>P85070</p>	<p>CE certified machine</p>
 <p>S20097</p>	<p>S20097</p>	<p>Motor rotation direction</p>
 <p>099504</p>	<p>099504</p>	<p>Visible and/or invisible laser radiation. Avoid eye or skin exposure to direct or scattered radiation.</p>
 <p>TVS 505346</p>	<p>505346</p>	<p>Tensioner Valve Handle Placement, TVS</p>

TABLE 1-1

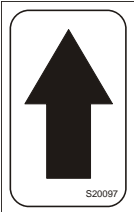
 <p>SVS 505347</p>	505347	Tensioner Valve Handle Placement, SVS																													
<table border="1"> <thead> <tr> <th rowspan="2">Type</th> <th colspan="2"></th> <th colspan="2">505348</th> </tr> <tr> <th>F[mm]</th> <th>E[mm]</th> <th>psi</th> <th>bar</th> </tr> </thead> <tbody> <tr> <td>275</td> <td>1,07</td> <td>32</td> <td>830-850</td> <td>57-59</td> </tr> <tr> <td>375 376</td> <td>1,14</td> <td>32 38</td> <td>745-765</td> <td>51-53</td> </tr> <tr> <td>2735</td> <td>1,07</td> <td>35</td> <td>805-825</td> <td>55-57</td> </tr> <tr> <td>576 476</td> <td>1,27 1,40</td> <td>38</td> <td>715-735</td> <td>49-51</td> </tr> </tbody> </table>	Type			505348		F[mm]	E[mm]	psi	bar	275	1,07	32	830-850	57-59	375 376	1,14	32 38	745-765	51-53	2735	1,07	35	805-825	55-57	576 476	1,27 1,40	38	715-735	49-51	505348	Blade Tension Values
Type				505348																											
	F[mm]	E[mm]	psi	bar																											
275	1,07	32	830-850	57-59																											
375 376	1,14	32 38	745-765	51-53																											
2735	1,07	35	805-825	55-57																											
576 476	1,27 1,40	38	715-735	49-51																											

SECTION 2 OPERATION

2.1 General Information

Thank you for choosing Wood-Mizer wood processing equipment!

Wood-Mizer is committed to providing you with the latest technology, best quality and strongest customer service available on the market today. We continually evaluate our customers' needs to ensure we're meeting current wood-processing demands. Your comments and suggestions are welcome.

The present documentation contains information that should be used when preparing the machine for operation, working with it and when servicing or repairing it, as well.

TVS saw is intended for sawing wood only. The machine must not be used for any other purposes such as cutting ice, metal or other materials.

Using the machine correctly, you will obtain a material of the highest quality and high degree of accuracy.

The TVS saw should be operated only by an adult who has read and understood the entire operator's manual.

The machine is built to be durable and easy to operate and maintain.

See Figure 2-1. The TVS main components are shown below.

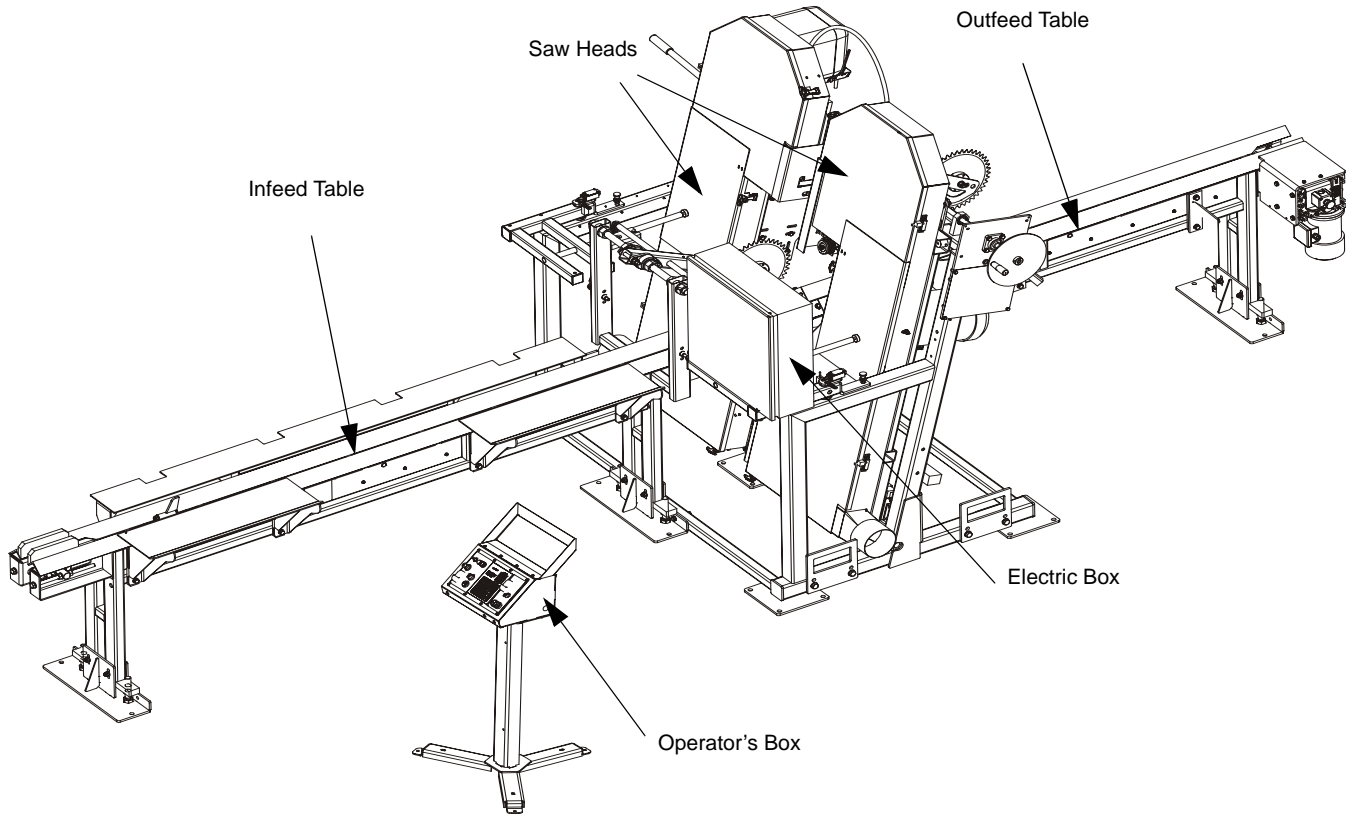

FIG. 2-1 TVS MAIN COMPONENTS

If You Need To Order Parts

From Europe call your local distributor or our European Headquarters and Manufacturing Facility in Kolo, Nagórna 114 St, Poland at +48-63-2626000. Please have the machine identification number and your customer number ready when you call. Wood-Mizer will accept these methods of payment:

- Visa, Mastercard, or Discover
- COD
- Prepayment
- Net 15 (with approved credit)

Be aware that shipping and handling charges may apply. Handling charges are based on size and quantity of order. In most cases, items will ship on the day they are ordered. Second Day and Next Day shipping are available at additional cost.

If You Need Service

2 OPERATION

Control Overview

From Europe call your local distributor or our European Headquarters and Manufacturing Facility in Kolo, Nagórna 114 St, Poland at +48-63-2626000. Ask to speak with a Customer Service Representative. Please have your machine identification number and your customer number ready when you call. The Service Representative can help you with questions about the operation and maintenance of your machine. He also can schedule you for a service call.

Office Hours:

Country	Monday - Friday	Saturday	Sunday
Poland	7 a.m.- 3 p.m.	Closed	Closed

2.2 Control Overview

1. Control Panel

See Figure 2-2. The control panel includes switches to start and stop the feed track and the saw heads.

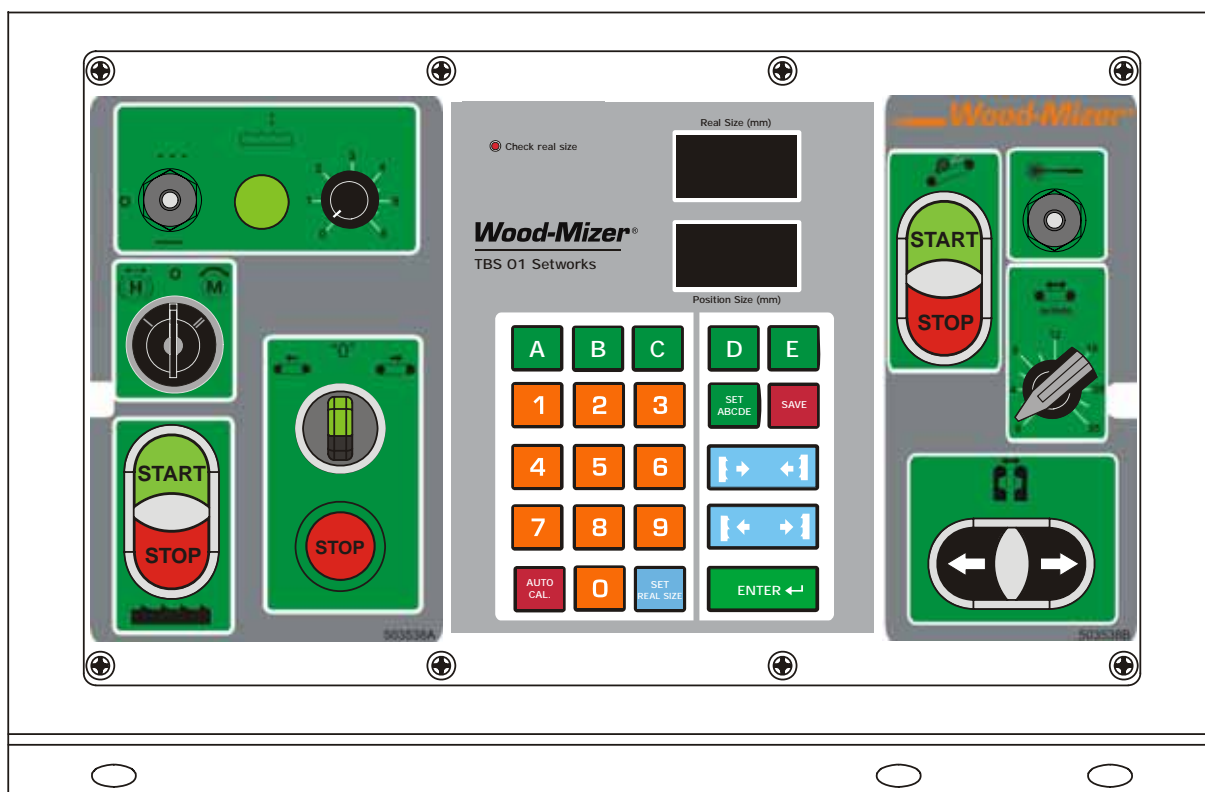

FIG. 2-2 CONTROL PANEL COMPONENTS

2. Blade Drive



To start the blade motor, turn the key switch to the  position. Then press the START button. To stop the blade motor, press the STOP button.

3. Feed Track



To start spinning the feed track forward, turn the switch right. To start spinning the feed backward turn the switch left. To stop the feed track press the stop button.



4. Feed Track Speed Adjustment



The feed track speed switch controls the speed at which the feed track moves. Turn the switch right to increase the speed, turn left to reduce the speed.

5. Key Switch

The key switch has three positions:

- “0” position - all electrical circuits are off,
-  position - all electrical circuits are on,
-  position - releases the motors disk brake, it is possible to run the track feed motor but it is not possible to run the blade feed motor.

6. Adjusting the distance between saw heads (optional)



Buttons enable adjusting the distance between the saw heads.

7. Loading ramp On/Off

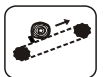

8. Lasers (optional)



Lasers show the cutting positions.

9. Lube Mizer



Lube Mizer control switch



Lube Dial

10. Emergency Stop

Push the emergency stop button to stop the blade and the track feed motors. Turn the emergency stop clockwise to release the stop. The machine will not restart until the emergency stop is released.

11. **TBS01 Networks - optional equipment** ([Section SECTION 3 NETWORKS OPERATION \(Optional Equipment\)](#))

2.3 TVS Setup



IMPORTANT! Before starting to use the machine you have to meet the following conditions:

- Set up the machine on firm and level ground.
- The machine can be operated with the sawdust collection system only.
- The machine can be operated under roof only.
- The machine can be operated in temperature range from -15° C to 40° C (5°F to 104°F) only.
- The illumination at the operator's position should be at least 300lx¹.
- The machine operator's position is shown below.

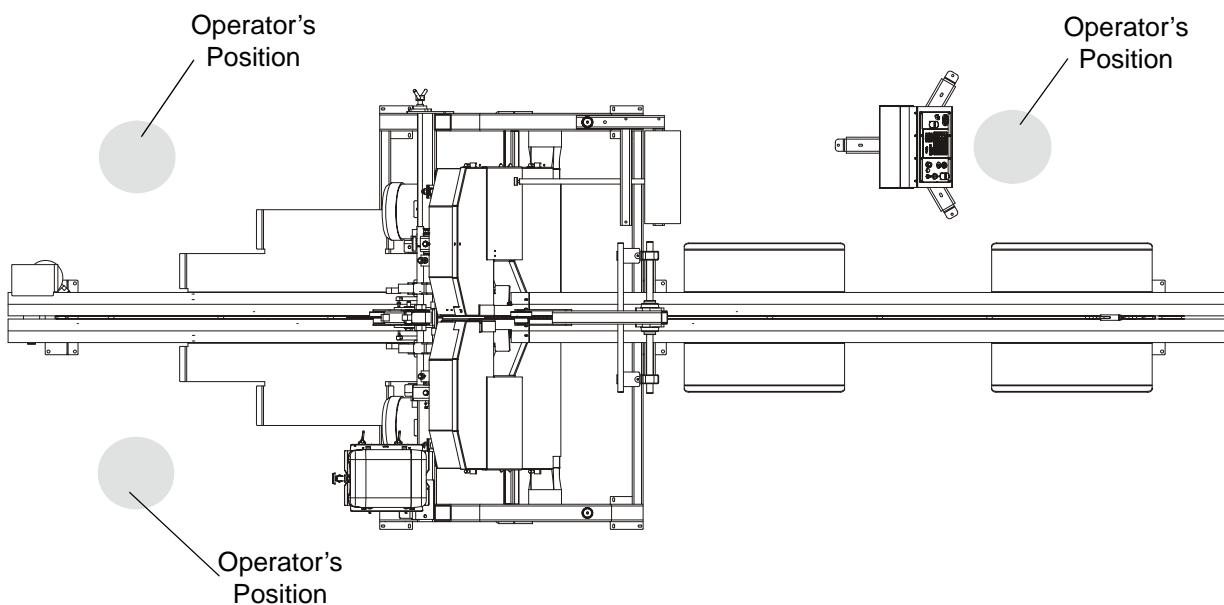

- Have a qualified electrician install the power supply (according to EN 60204 Standard). The power supply must meet the specifications given in the table below.

3-Phase Volts	Fuse Disconnect	Suggested Wire Size
400 VAC	40 Amp	11 AWG / 4 mm ² , up to 15 m/ 49 ft long

TABLE 2-1

1. The light source can not cause stroboscopic effect.



IMPORTANT! When starting the machine for the first time, check that blade rotation direction is as indicated by the arrow located on the blades covers. If the rotation direction is incorrect, invert the phases in the phase inverter located in the power socket (electric box). Setting the phases in the phase inverter correctly will ensure correct rotation directions of all machine motors (machines not equipped with phase failure relay). If your machine is equipped with phase failure relay, motors will not start until the phase are not set properly.



IMPORTANT! When starting the machine for the first time, let it run without any load for 1-2 hours. It will let the infeed and outfeed tables drive components to grind in.



DANGER! It is recommended that a 30mA Ground Fault Interrupter (GFI) be used.

- The resaw can be lifted using the forklift only. Forklift must be rated for at least 2000kg (4409 lb). Resaw is equipped with forklift pockets. Insert the forks into the pockets shown on the picture below.

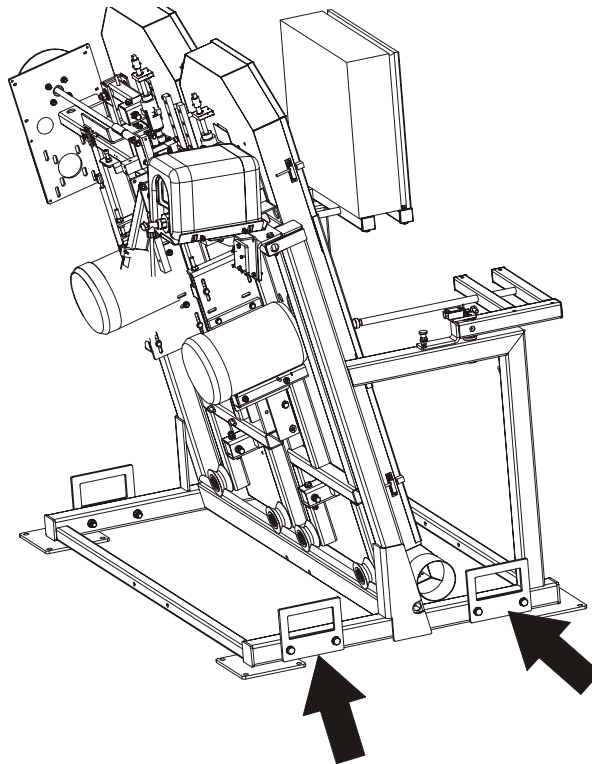



FIG. 2-2

2.4 Replacing The Blades

 **DANGER!** Always shut off the machine motors before changing the blades. Failure to do so may result in serious injury.

 **WARNING!** Always wear gloves and eye protection whenever handling bandsaw blades. Changing blades is safest when done by one person! Keep all other persons away from work area when changing blades. Failure to do so may result in serious injury.

Move the control box arm and next open the blade housing cover. Turn the blade tension valve handle to “0” position to release the blade tension until the wheel is pulled in and the blade is lying loose in the blade housing. Lift the blade out of the blade housing.

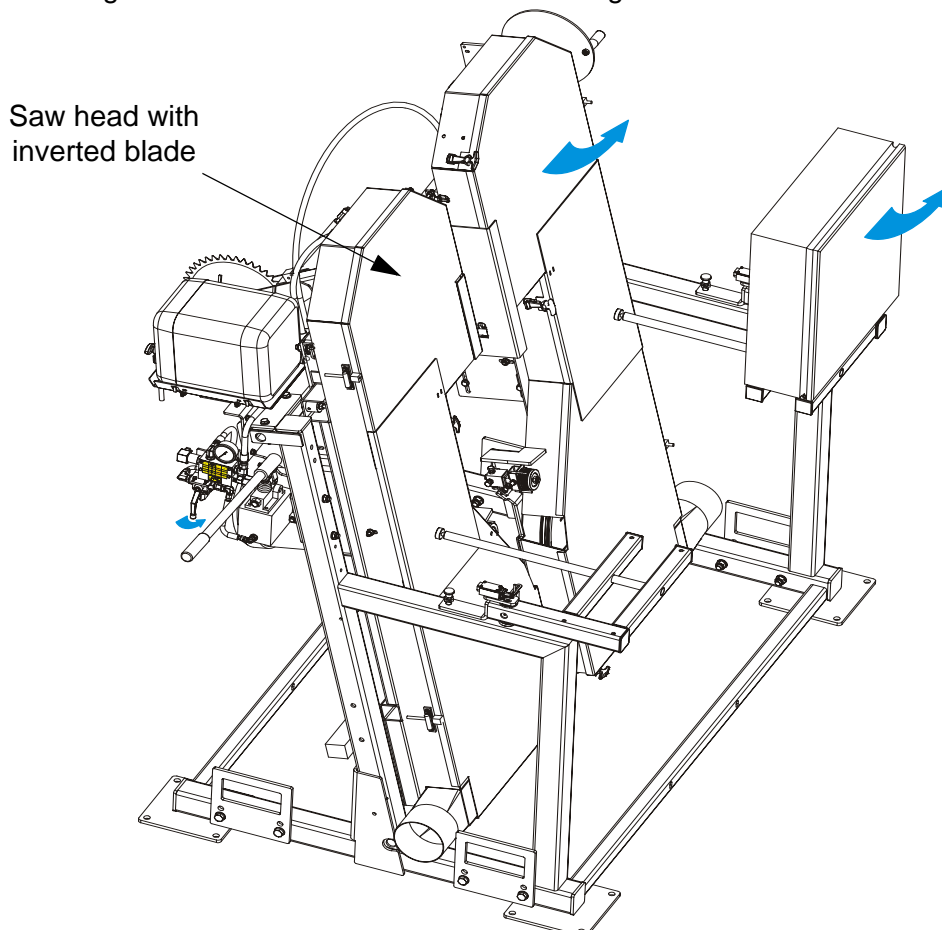

Install a new blade around the two blade wheels so that the teeth located between the blade guide assemblies point to the infeed table. Make sure the teeth are pointing the correct direction.

Position 1 1/4" (31.75 mm) wide blades on the wheels so the gullet is 3.0 mm (0.12") (± 1.0 mm / (0.04")) out from the front edge of the wheel.

Close the blade housing cover.

2 OPERATION

Tensioning The Blades

Next, tension the blade as described in the following instructions.

NOTE: Before installing the blade on the left (when facing the operator box) saw head, invert the blade ([See Section 4.3 Inverting The Blade in "Blade Handbook"](#)).

2.5 Tensioning The Blades

See **Figure 2-3**. Place the provided handle in the blade tensioner socket and secure with a screw. Set the tensioner valve to position "1". Move the tensioner handle up and down to tension the blade. Depends on the installed blade type, tension the blade to the value shown on the decal located below blade tension valve. Values "F" and "E" are: blade thickness and blade width. Check the blade tension occasionally when adjusting the cant control or while cutting and adjust if necessary. As the blade and belts heat up and stretch, the blade tension will change. Also, ambient temperature changes can cause tension to change. To release the blade tension set the tensioner valve to "0"

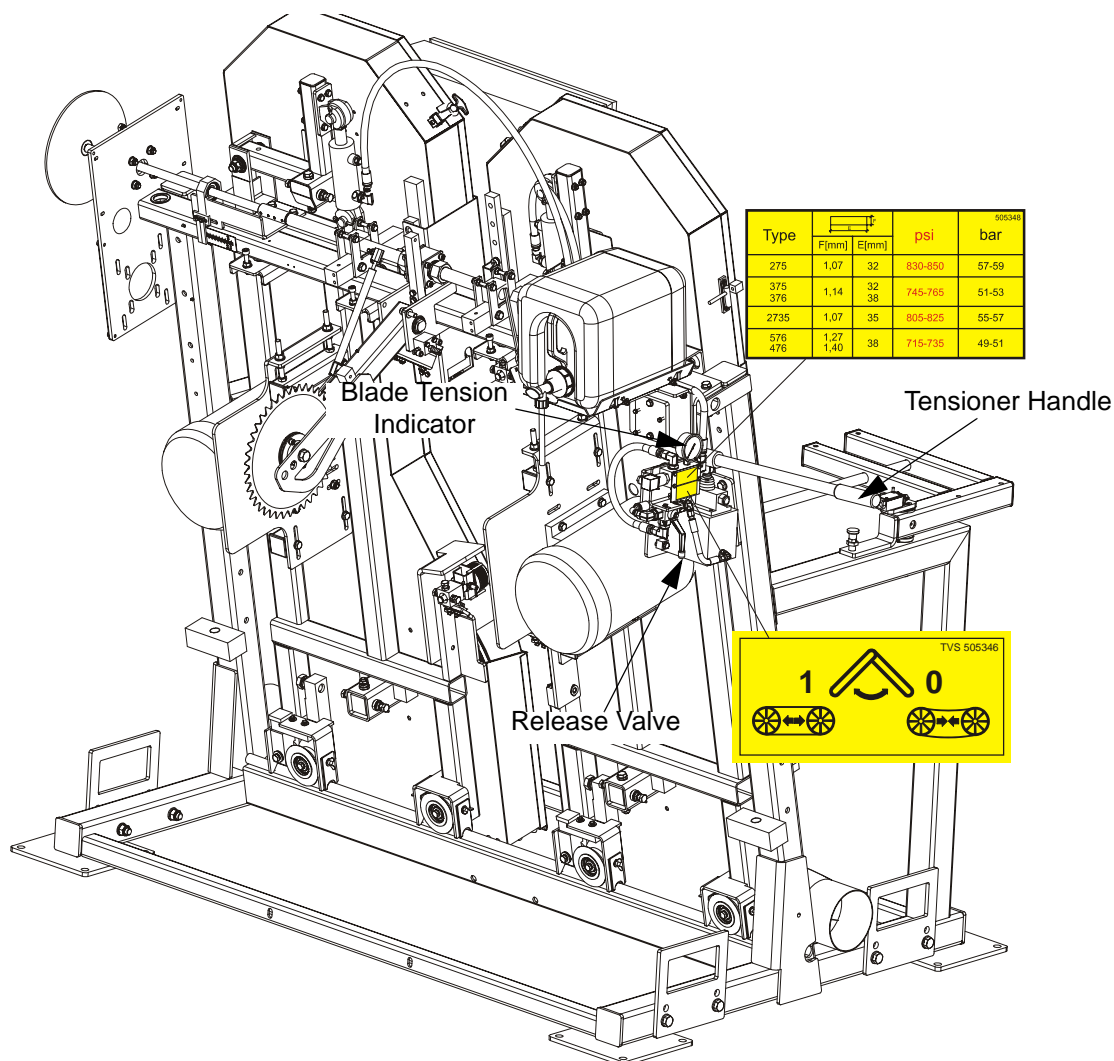

FIG. 2-3

position.



CAUTION! Always release the blade tension when the machine is not in use.

2.6 Tracking The Blade

1. Open the blade housing cover of each saw head.
2. Turn the key switch to the "H" position.



3. Manually spin one of the blade wheels until the blade positions itself on the blade wheels.
4. Check that the blade is properly positioned on the blade wheels.

See Figure 2-4. 1 1/4" wide blades should be placed on the blade wheels so that the gullet is 3.0 mm (0.12") \pm 1.0 mm (0.04") out from the front edge of the wheel.

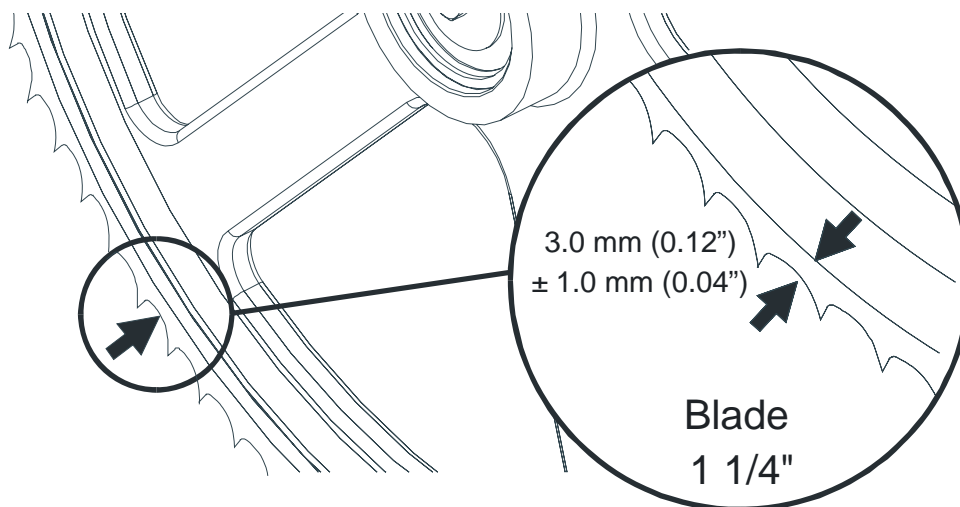

FIG. 2-4

5. Use the cant adjustment bolt, shown in **Figure 2-3**, to adjust where the blade travels on the blade wheels.

To move the blade out on the blade wheel, turn the cant adjustment bolt clockwise.

To move

the blade in on the blade wheel, turn the bolt counterclockwise.

6. Adjust the blade tension if necessary to compensate for any changes that may have occurred while adjusting the cant control.

7. Close the blade housing cover.



CAUTION! Make sure all guards and covers are in place and secured before operating or towing the machine. Failure to do so may result in serious injury. Be sure the blade housing cover is in place and secured.

NOTE: After aligning the blade on the wheels, always check the blade guide spacing and location.

2.7 Machine Start



DANGER! Before starting the machine, perform these steps to avoid injury and/or damage to the equipment:

- Close the blade housing covers and replace any guards removed for service.
- Check the feed track and remove all loose objects such as tools, wood, etc.
- Check that the blades are properly tensioned.
- Make sure all persons are a safe distance from the machine.
- Check that the emergency stops are released.

NOTE: The machine will not start if either of the emergency stops is on.

Before starting the saw heads, check that the main power switch servicing the machine is on.

See Figure 2-5. Start the blade motors. To do this, turn the key switch to the  position and then push the Blade START button on the control panel (see the figure below). The motors should start and the blades should start spinning.

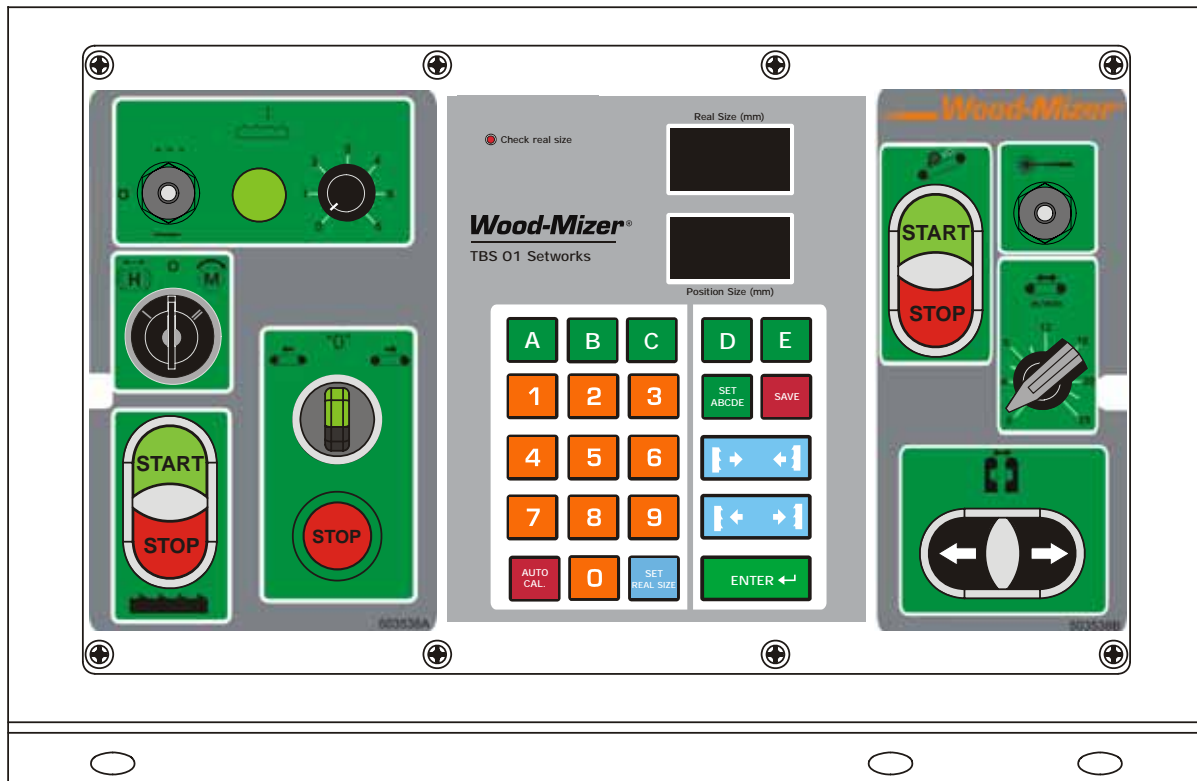

FIG. 2-5

To stop the blade motors, push the Blade Stop button shown in the figure above. The blade motors also may be stopped by pushing either of the emergency stop buttons.

If either of the emergency switches has been used to stop the blade motors, turn the switch clockwise before restarting the saw heads. The saw heads cannot be restarted until the emergency stop button is released.

2 OPERATION

Machine Start

See Figure 2-6. After the saw heads have been successfully started, the feed track can be started.

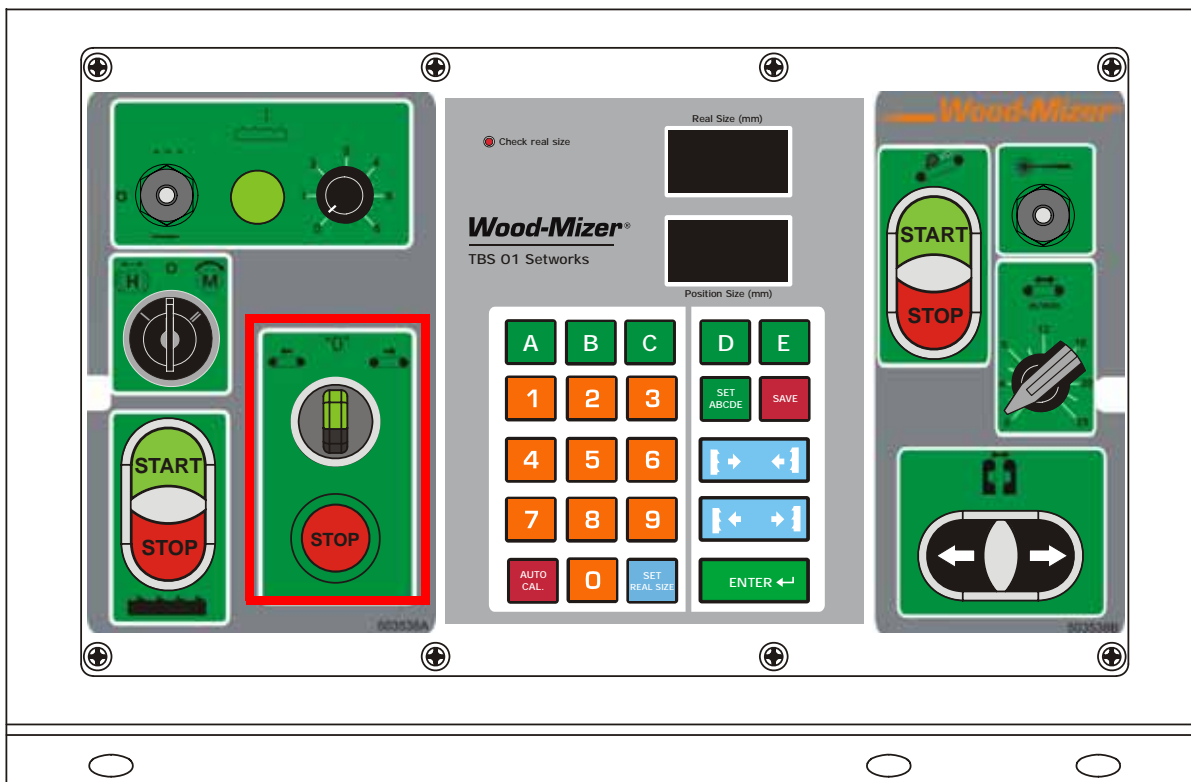

FIG. 2-6

To start the track chain motor, turn the Track Start switch (shown in Figure 2-6) right to start the track forward, turn the switch left to start the track backward. To stop the track press the STOP button placed under Track Start switch.

The feed track can be stopped by pressing one of the emergency stop buttons. The emergency stop will also stop the blade motor.

NOTE: The feed track cannot be started if the blade motor is not started.

See Figure 2-7. The speed at which the feed track moves is adjustable. The feed track speed switch,

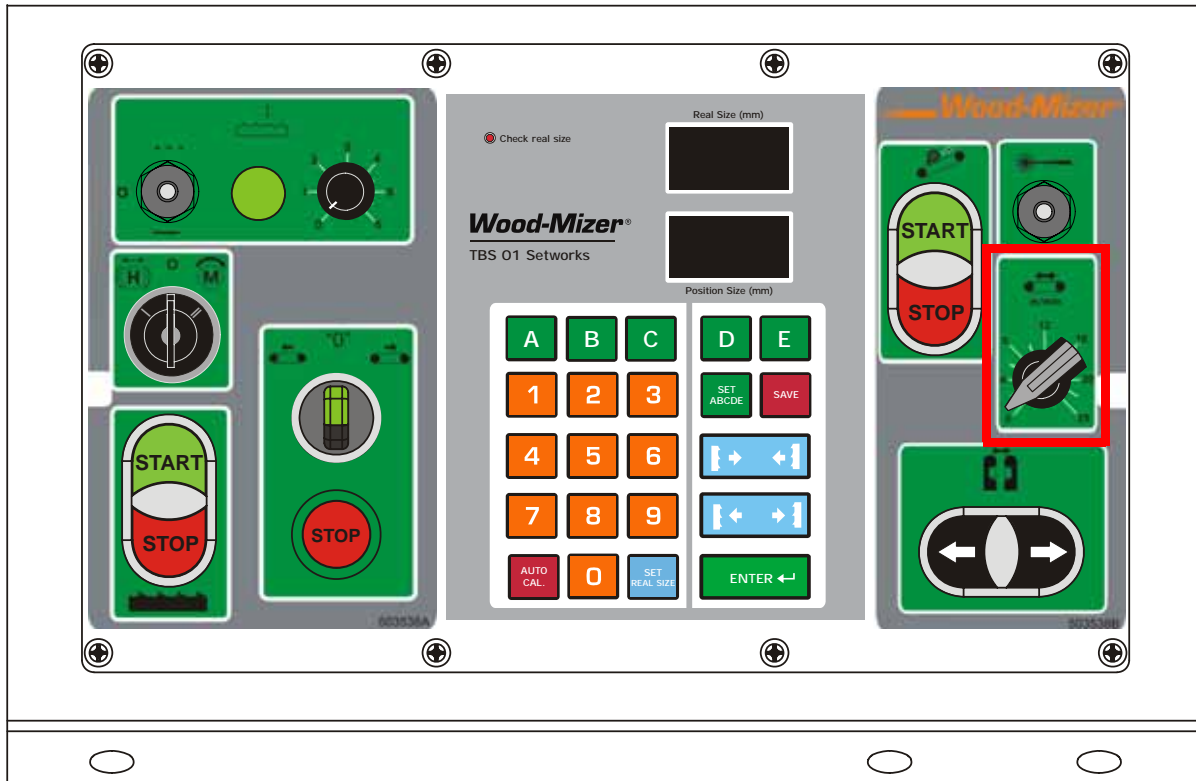

FIG. 2-7

located on the control panel, allows the operator to adjust the feed rate from 0 to ca. 25 m (82 ft) per minute.

Turn the switch clockwise to increase the feed rate, counterclockwise to slow the feed rate down.

Factors that will determine what feed rate you can use include:

- Log diameter.
- Hardness of material to be cut. Some woods that are seasoned or naturally very hard will require slower feed rates.
- Sharpness of blades. Dull or improperly sharpened blades will require slower feed rates than sharp and properly maintained blades.
- Off-bearing capability. Your ability to feed will also determine what feed rate you can use.

2.8 Cutting Width Setting

1. Install a blade if needed and check for correct blade tension. ([Section 2.5 Tensioning The Blades.](#))
2. Set the saw heads at the desired width using the handle and width scale shown in the figure below.

See Figure 2-8. To move the saw heads in, turn the handle left. To move saw heads out, turn the handle right.

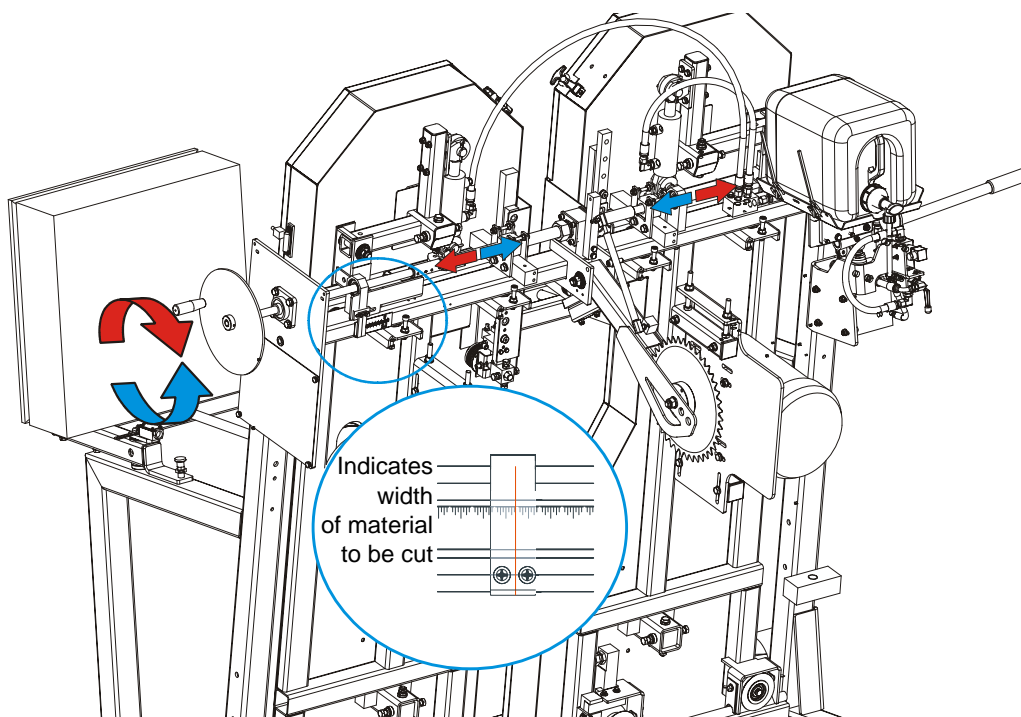

FIG. 2-8

2.9 The LubeMizer System

Lube Mizer system is used to lubricate the blade during sawing. The LubeMizer applies lubricant on both sides of the blade as you are sawing to reduce resin buildup on the blade. The LubeMizer controls allow you to adjust the volume of lubricant for various wood types. The LubeMizer option uses less volume than the standard Water Lube, helping to reduce lubricant/sawdust mess and waste, and to prevent stained boards.

Usual flow will be between 2.6 - 9.5 liters (0,687 - 2,5 gallon) per hour.

1. To start the self-priming system,
 - Open the water lube bottle valve all the way.

- Turn the lube control switch to PULSE¹ and set the lube dial to the desired flow rate. Use the lowest setting that successfully eliminates pitch buildup.

NOTE: Softwood applications will usually require more lubricant than hardwood applications.

2. Cut the log.

3. To shut of the lube,

- Turn the lube control switch to OFF.
- Close the lube bottle valve all the way.

4. If you are sawing or storing the machine in freezing temperatures, use windshield washer fluid to help prevent the water from freezing.



CAUTION! Add windshield washer fluid to the water tank and prime as recommended when sawing or storing the machine in below-freezing temperatures. Use windshield washer fluid with a freezing point of at least -20°F (-29°C). Failure to do so will cause damage to the LubeMizer system may result.

Lube Additives

For further benefits, add one 12oz. (0.35 L) bottle of Wood-Mizer Lube Additive to a 5 gallon (18.9 L) jug of water. Wood-Mizer Lube Additive enables some previously impossible timbers to be cut by significantly reducing resin buildup on the blade. It helps to reduce heat buildup, wavy cuts, and blade noise. This biodegradable and environmentally friendly pre-mix includes a water softener additive, so it works with hard water.



WARNING! Use ONLY water, Wood-Mizer Lube Additive or windshield washer fluid with the water lube accessory. Never use flammable fuels or liquids such as diesel fuel. If these types of liquids are necessary to clean the blade, remove it and clean with a rag. Failure to do so can damage the equipment and may result in serious injury or death.

¹Pulse is suitable for most cutting applications. CONTINUOUS delivers a steady stream of lubricant and should be used only for heavy pitch buildup or occasional blade cleaning.

See Table 2-1. Use windshield washer fluid as an antifreeze to prevent the water from freezing and damaging the LubeMizer system. See the chart below for recommended mixture levels depending on the temperature where you are sawing or storing the machine.

Run the LubeMizer system on the “Continuous” setting for 30 seconds after adding the windshield washer fluid to the system. This will insure the water throughout the system will not freeze and damage the check valves.



CAUTION! Add windshield washer fluid to the water tank and prime as recommended when sawing or storing the machine in below-freezing temperatures. Use windshield washer fluid with a freezing point of at least -20°F (-29°C). Failure to do so may cause damage to the LubeMizer system.

Ratio WWF ¹ :Water to fill 5 Gal. tank	Freezing Point Of Solution	
	(°F)	(°C)
5:0	-22	-30
4:1	-3	-19
3:2	7	-14
2.5:2.5	13	-10
1:4	24	-4
0:5	32	0

TABLE 2-1

¹ WWF = Windshield Washer Fluid with -20°F (-29°C) freezing point.

2.10 Operation Procedure

1. Install a blade if necessary.



WARNING! Always wear gloves and eye protection when handling bandsaw blades. Changing blades is safest when done by one person! Keep all other persons away from area when coiling, carrying or changing a blade. Failure to do so may result in serious injury.

2. Close the blade housing cover.
3. Tension the blade as described in [Section 2.5 Tensioning The Blades](#).
4. Slowly spin the blade wheel by hand.



WARNING! Use extreme caution when spinning the blade wheel by hand. Make sure hands are clear of blade and wheel spokes before spinning. Failure to do so may result in serious injury.

5. Check alignment of the blade on the blade wheels and blade guides. Adjust as necessary.
6. Set the cutting width as desired.



DANGER! Make sure all guards and covers are in place and secured before operating the machine. Failure to do so may result in serious injury.

7. Perform pre-start check. [Section 2.3 TVS Setup](#).
8. Start the blade motors.
9. Turn on the Lube Mizer system.
10. Using the feed track speed switch, set the feed rate as desired.



DANGER! Always be sure all persons are out of the path of the blade before starting the motor. Failure to do so will result in serious injury.



WARNING! Always wear eye, ear, respiration and foot protection when operating or servicing your machine.

11. Place the test material on the feed track and start the feed track.



DANGER! Always be aware of and take proper protective measures against rotating shafts, pulleys, fans, etc. Always stay a safe distance from rotating members and make sure that loose clothing or long hair

does not engage rotating members resulting in possible injury.

12. Shut off the blades and feed track. Measure the finished material and adjust the saw heads in or out as necessary. Repeat with the test material until the desired finished dimension is obtained.
13. Restart the blade and feed track.
14. Place material on the infeed table.
15. Monitor blade tension as operation continues. Adjust blade tension if required.
16. If material jam occurs, stop the blade motor and feed track.



WARNING! Allow blade to come to a complete stop before servicing. Failure to do so will result in serious injury.

17. After operation is complete, shut off the blade motor and feed track.
18. Release blade tension if done sawing for the day.



CAUTION! Remove tension from the blade when the machine is not in use.

2.11 Loading Ramp Operation

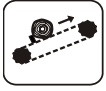

Use the switch located on the operator panel to turn on/off the log ramp.



CAUTION! Minimum log length which can be handle by the loading ramp is 700mm (27,56"). Log must be placed so, that the limit switch would be activated when the log will reach the end of the ramp.

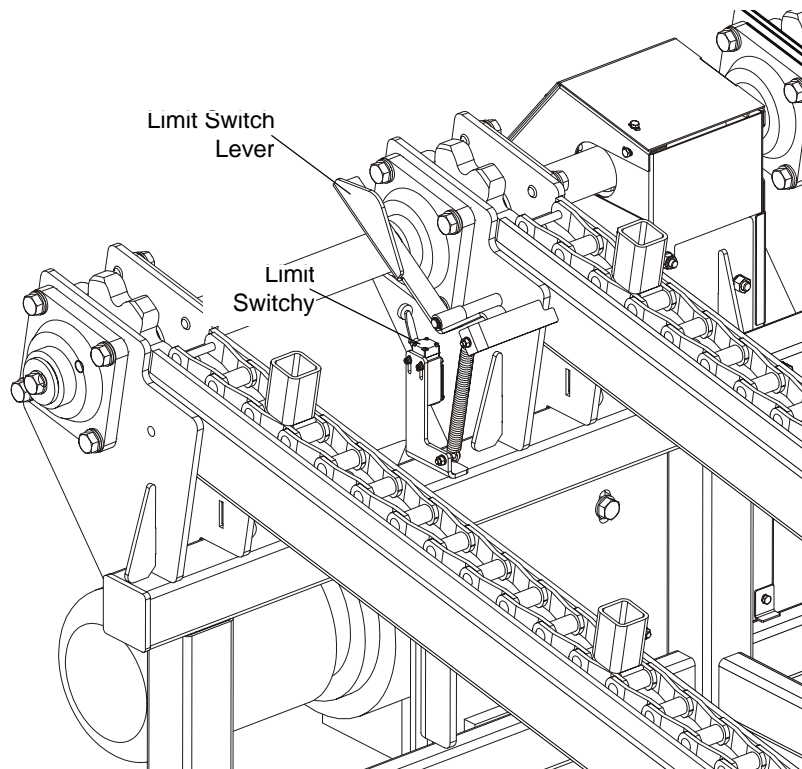

FIG. 2-8



DANGER! If there are many logs on the ramp, be extremely carefull when taking out the logs. First take the upper logs and be carefull not to release the limit switch which will start the feed and may cause the operator crush.



WARNING! Securely fasten the feet of a log deck to the floor before operating the machine. Failure to do so may result in serious injury or death.



CAUTION! Never drop logs onto the log deck from a height more than 20 cm (7,874") when loading. Failure to do so may result in damage to the log deck.

2.12 Cross Transfer Deck Operation

Use the START/STOP button located on the electric box to turn on/off the transfer deck. If there is any danger to persons or equipment, press the emergency button. It will stop the transfer deck and TVS resaw. Turn the emergency stop clockwise to release the stop. The machine will not restart until the emergency stop is released.



FIG. 2-8

 **DANGER!** Be extremely carefull when picking up slabs from the ground. Operator may be hit by falling slabs from the deck.

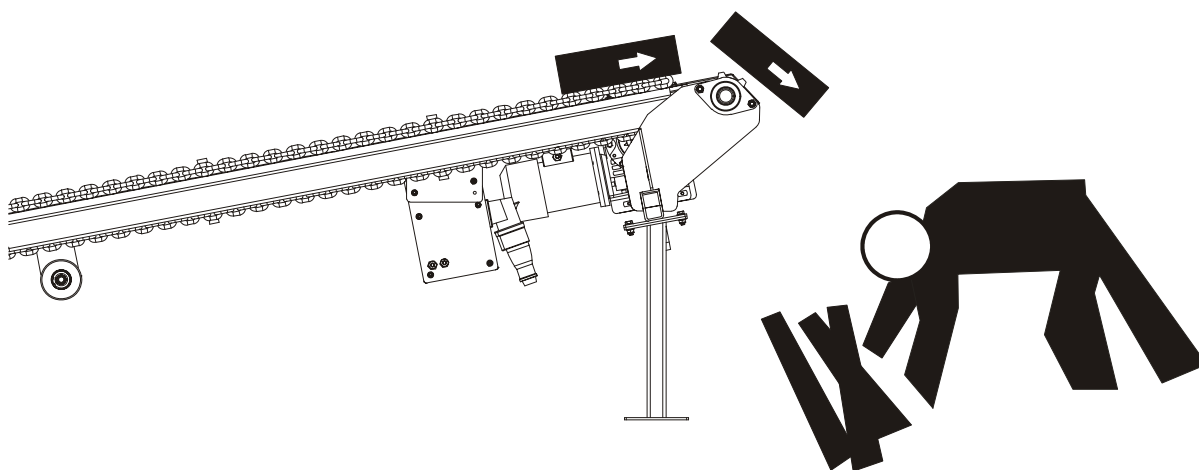
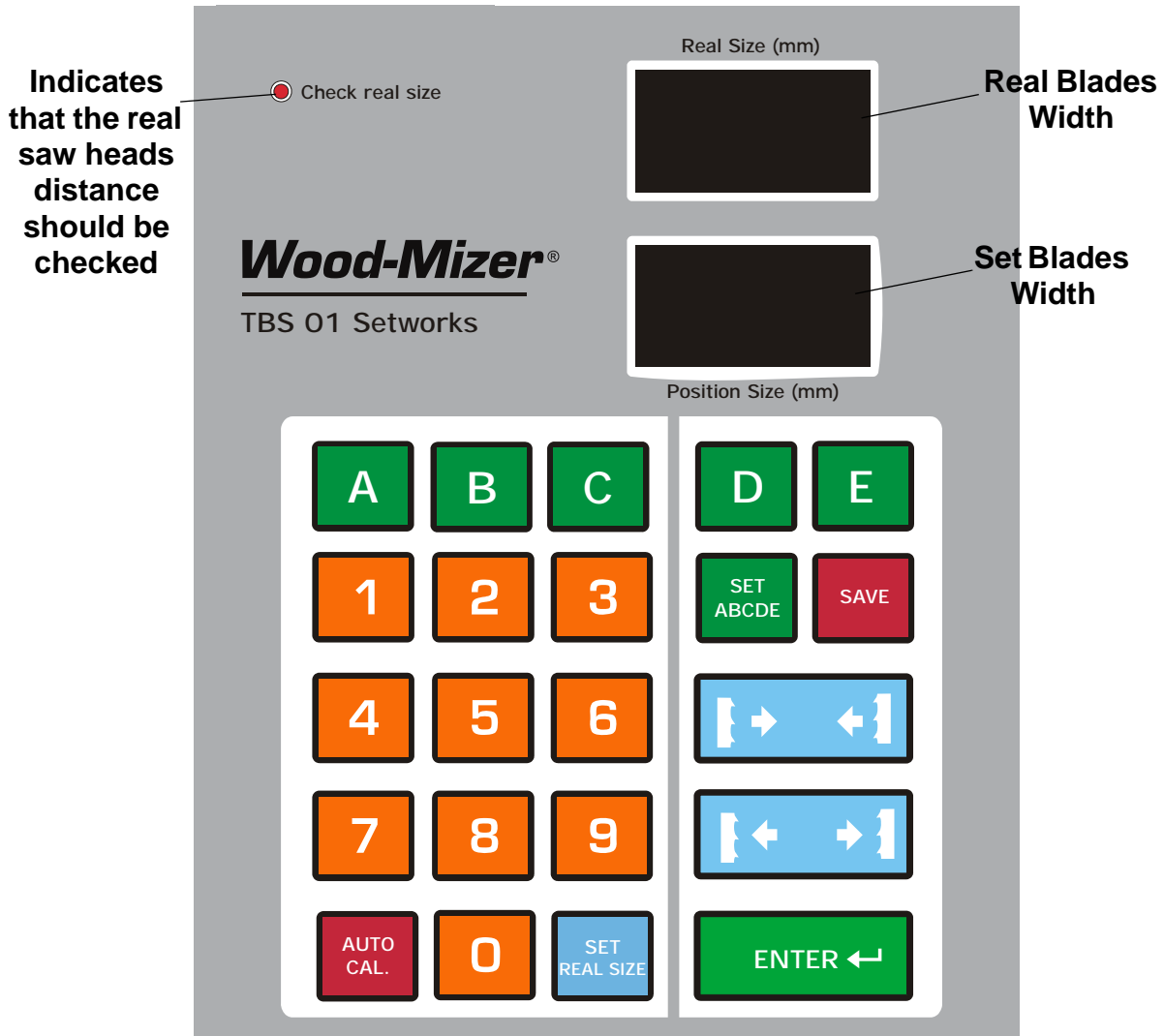

FIG. 2-8

SECTION 3 NETWORKS OPERATION (OPTIONAL EQUIPMENT)

3.1 TVS Controller Panel

See Pic. 3-1.



PIC. 3-1

Descriptions of the control panel buttons:

A, B, C, D, E - Heads width memory buttons.



SET ABCDE - Sets the blades width value to each memory button.



Save - Saves parameters determined by the operator.



Blades width manual setting buttons (in/out).

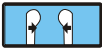

ENTER ← – enters values to the memory.





Auto Mode – Adjustment of the SW-08 automatic calibration parameters. Used for initial calibration and recalibration if a dimensional error occur.



Set Real Size - Sets the real distance between the saw heads. Should be set when the “Check real size” indicator lamp is blinking.

3.2 Start-up Settings of the Controller

1. Setting the input divider (entered only once, at the first start-up)

- Turn the main switch to the ON position.
- Turn the key switch to  position.
- When "TBS-01" appears on the display, press and hold  until the divider value appears on the lower right display.
- Enter the correct value of the divider (for TVS the divider value should be 5).

See Pic. 3-2.

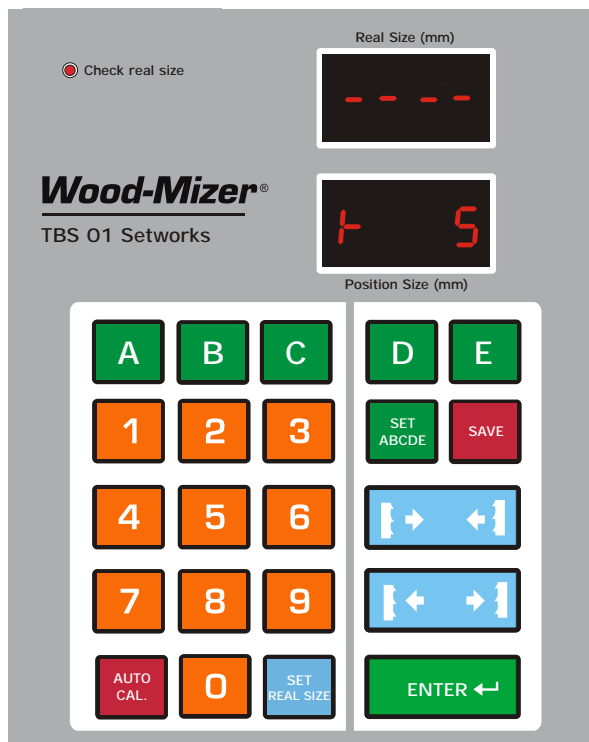





PIC. 3-2

- Press  to save the entered divider value.

2. Auto-calibration

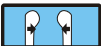

This function should also be used in case of: replacement of the screw of blades width setting system, the motor or after lubrication of the screws and other moving elements of the heads or when significant cutting variances are observed;

- Turn the main switch to the ON position.
- Turn the key switch to  position and wait until "TBS-01" disappears.
- Set the head width to 80 mm using  buttons.

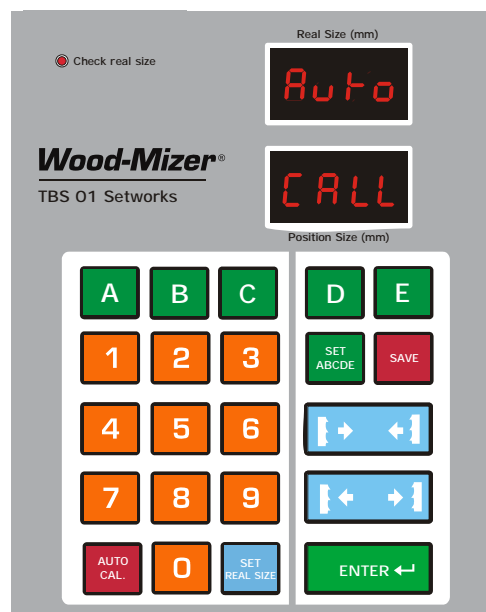
- Press and hold down . After a while - "Auto CALL" will appear on the displays. The controller is now ready for auto-calibration.

See Pic. 3-3.





PIC. 3-3

- Press  again, the controller successively performs several movements of the heads. After performing the last movement, measure and enter the real head width using the keypad. Confirm by pressing .
- The end of the function is signalled, "End CALL" appears and the normal mode of operation is restored.



NOTE: If, during the movement, the limit switch is activated, set different head width and repeat the auto-correction function.

3.3 Operation, Memory Buttons (A, B, C, D, E)

After switching-on, the "TBS-01" inscription appears on the display and the Networks is ready for operation within a few seconds or after  is pressed.

- To set the saw heads to any width, enter the heads width value and press . The saw heads will automatically move to the entered width value.

You can store up to 5 heads width values using the memory buttons.

- To store the width value using the memory button, press and hold . On the upper display the "ABC" will appear. Press the memory button (A, B, C, D or E), enter the width value and confirm by pressing . Perform the same procedure for other memory buttons. Press  to exit this function.

3

NETWORKS OPERATION (Optional Equipment)

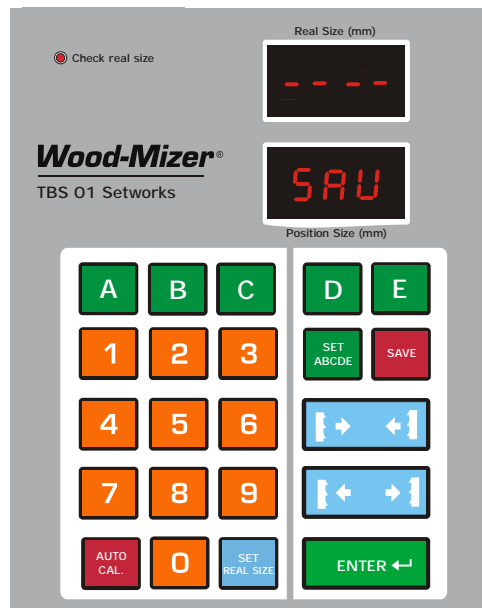

Operation, Memory Buttons (A, B, C, D, E)

See Pic. 3-4.



PIC. 3-4

- To use the stored value, press the required memory button and confirm by pressing . The saw heads will move to the stored width.

NOTE: If, during normal operation, the “Check real size” lamp starts blinking, press and hold the  button. Measure and enter the distance between the saw heads with an accuracy of 0,1 mm (0,0039”). For example: if you want to enter 102mm - press **1-0-2-0** without any pauses and confirm by pressing .

SECTION 4 TROUBLESHOOTING

4.1 Networks Malfunction

PROBLEM	CAUSE	SOLUTION
Networks does not work.	Magnet sensor improperly adjusted	Adjust the magnet sensor as shown on Photo 4-1 and Fig. 4-2 . Calibrate the controller. See Section Auto-calibration .
The controller calculates dimensions of boards incorrectly.	Improper input parameters	<ul style="list-style-type: none"> - Check the input divider (See Section Setting the input divider (entered only once, at the first start-up)). - Perform the auto-calibration procedure. See Section Auto-calibration.
During the auto-calibration procedure, the controller stops the saw heads and „Err Call” appears on the display.	During the auto-calibration procedure the limit switch is activated.	Set the head width to 110mm / (4.33”) before activating the auto-calibration procedure.
The saw heads do not stop when the required dimension is reached, but move inward or outward until the limit switches are activated.	Networks not calibrated	Check the input divider. Calibrate the Networks controller.
The Networks stops the saw heads and „Err P” is displayed.	Incorrect signal of the blades distance sensor	<ul style="list-style-type: none"> - Check the connections between the blades distance sensor and the Networks. See Photo 4-3. - Make sure the magnetic strip is not loose. - Check the connections to the contactors of the blades distance setting system.
During manual blades distance adjustment, the display shows a negative blades distance value.	Networks not calibrated	Calibrate the Networks controller.
”Pur” is shown on the display.	<p>If continuously - a loss of power.</p> <p>If blinks - the ribbon cable connecting the controller boards is broken.</p>	<p>Check the Networks supply voltage on the PWR terminals (it should be 12.5VDC). See Photo 4-4.</p> <p>Check the connection between the controller boards. Make sure the connector pins are not dirty. See Photo 4-5.</p>



PHOTO 4-1

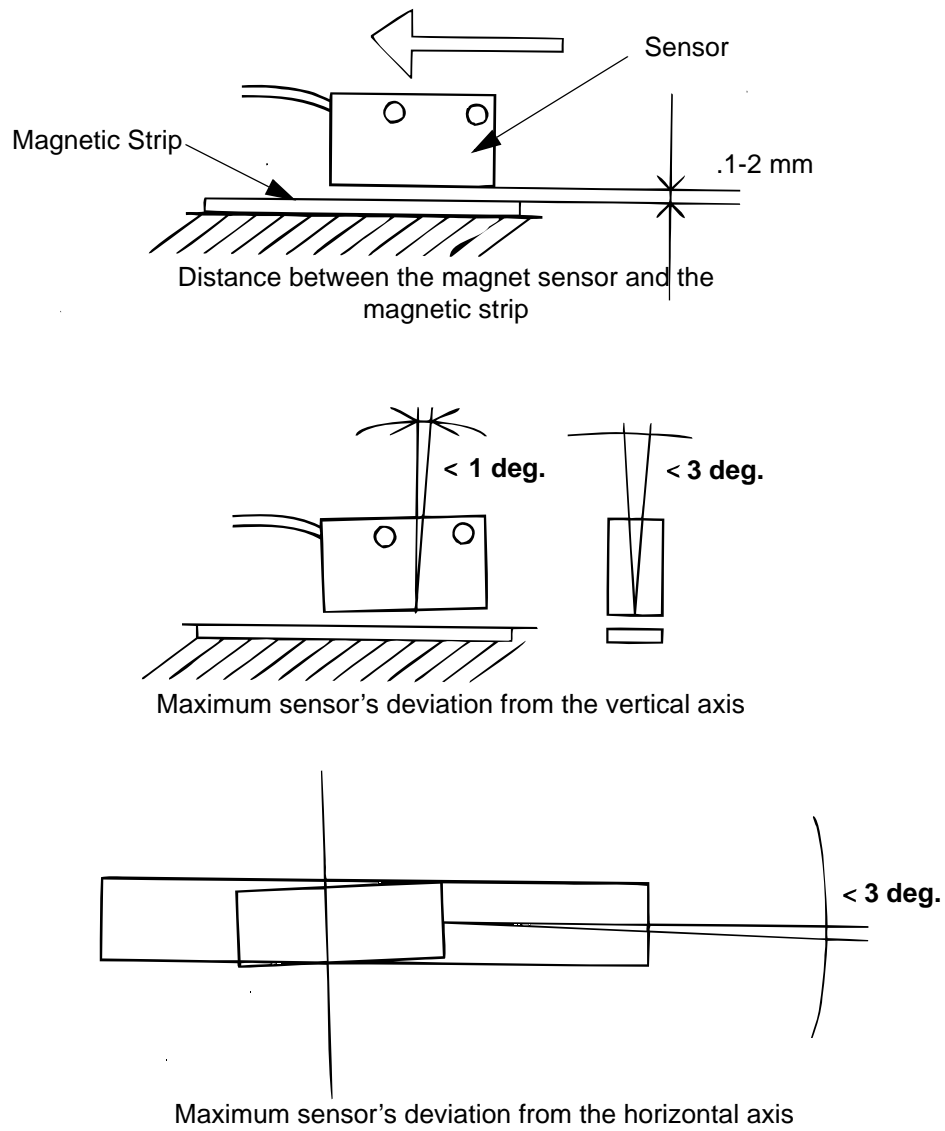

FIG. 4-2

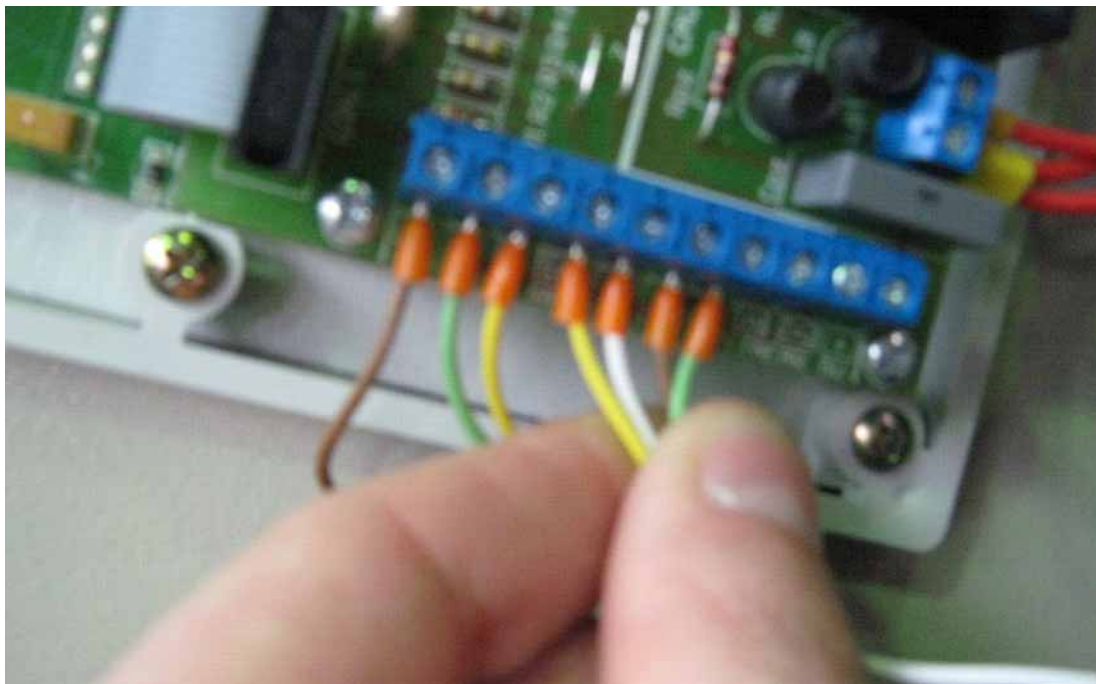

PHOTO 4-3



PHOTO 4-4

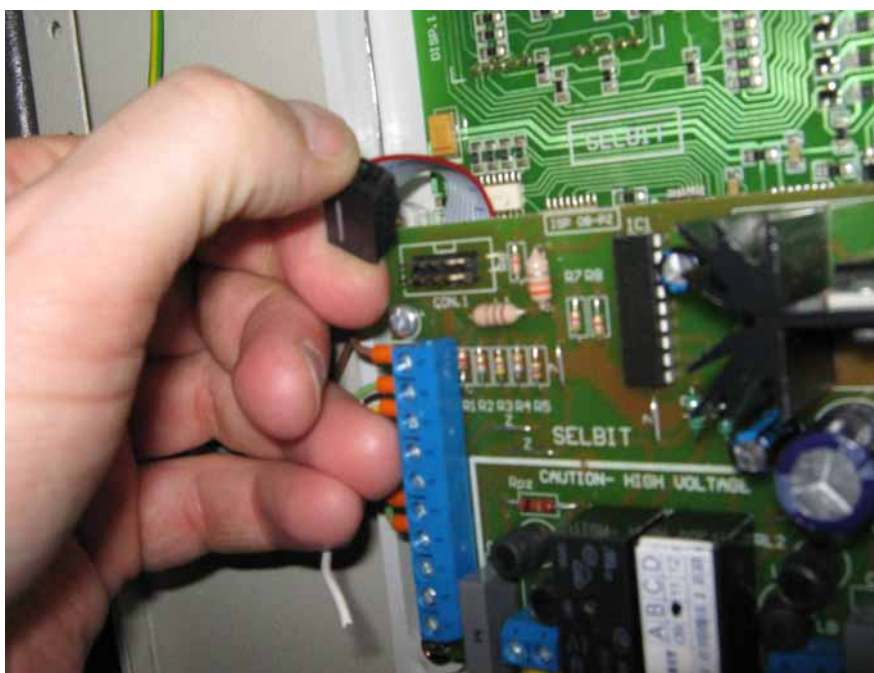

PHOTO 4-5

SECTION 5 MAINTENANCE

This section lists the maintenance procedures that need to be performed.



This symbol identifies the interval (hours of operation) at which each maintenance procedure should be performed.

Be sure to refer to the motor manual for maintenance procedures concerning the blade motor.

5.1 Wear Life

See Table 5-1. This chart lists estimated life expectancy of common replacement parts if proper maintenance and operation procedures are followed. Due to many variables which exist during resaw operation, actual part life may vary significantly. This information is provided so that you may plan ahead in ordering replacement parts.

Part Description	Estimated Life
B57 Blade Wheel Belts	500 hours
Blade Guide Rollers	1000 hours
Drive Belt	1250 hours

TABLE 5-1

5.2 Blade Guides

1. Check the rollers for performance and wear every blade change. Make sure the rollers are clean and spinning freely. If not, rebuild them. Replace any rollers which have worn smooth or have become cone shaped. See the Parts manual for blade guide rebuild kits and complete roller assemblies.

5.3 Sawdust Removal

1. Remove the excess sawdust from the blade wheel housing sawdust chute every blade change and saw heads lower rollers.

See Figure 5-1.

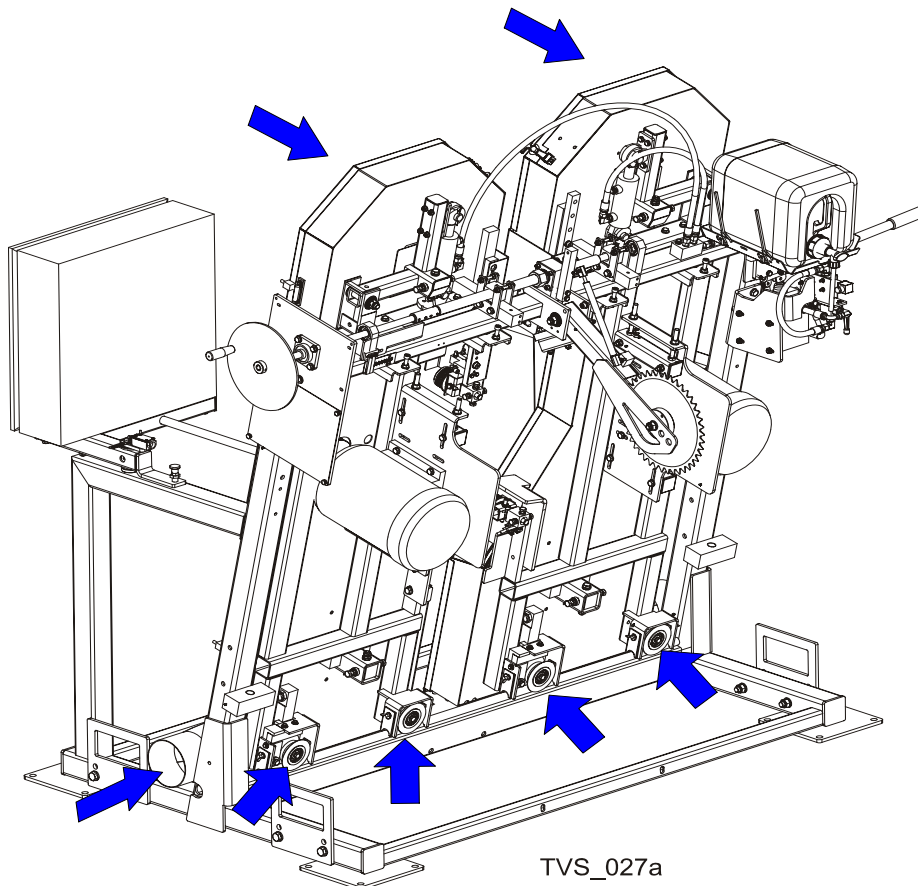

FIG. 5-1



CAUTION! Never use grease on the saw heads lower rollers as it will collect sawdust.

2. Remove the excess sawdust and slabs from the infeed and outfeed table, log deck and cross transfer deck.

5.4 Miscellaneous Lubrication

1. Apply a thin film of a lithium grease to the saw heads width adjustment screw to help prevent it from rusting.
2. Using the grease nipples, lubricate the chain drive shaft bearings, hold down roller bearing of the infeed table, saw heads width adjustment screw bearing with a lithium grease.



CAUTION! Never apply grease to the feed track chain. It causes sawdust buildup in chain links.

It

See Figure 5-2.

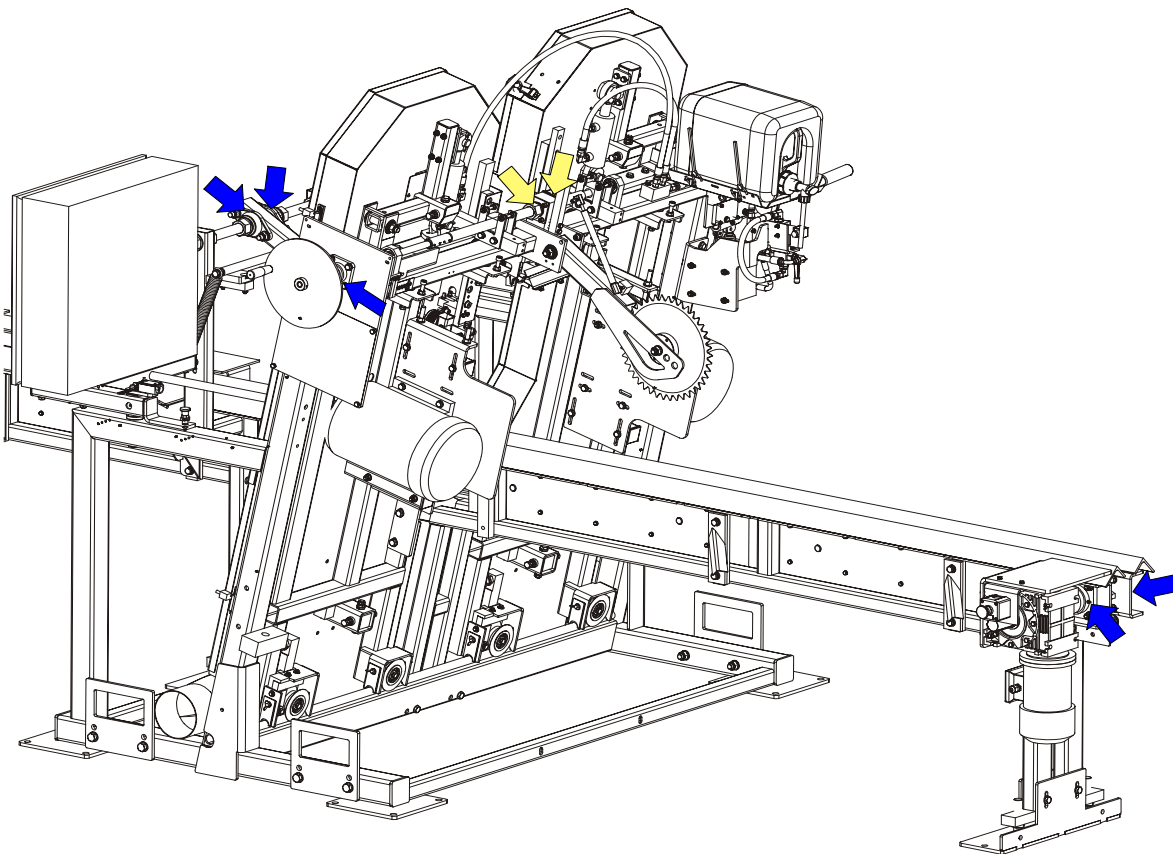

FIG. 5-2

3. If the TVS resaw is equipped with Log Deck and/or Cross Transfer Deck, lubricate the chain drive shaft bearings, using the grease nipples.

See Figure 5-3.

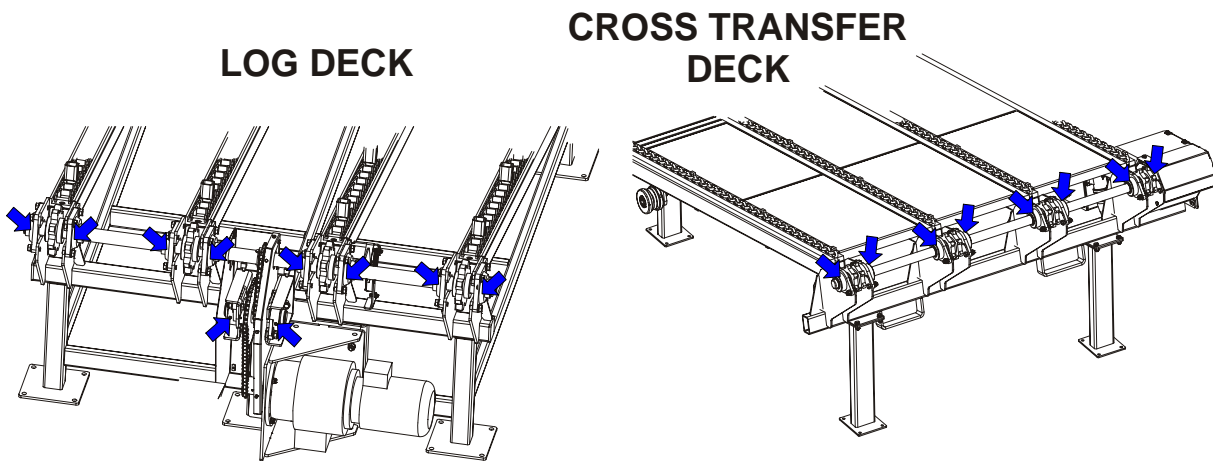

FIG. 5-3

4. Make sure all safety warning decals are readable. Remove sawdust and dirt. Replace any damaged or unreadable decals immediately. Order decals from your Customer Service Representative.

5.5 Belts

1. Check the blade wheel belts for wear every 50 hours of operation. Replace as needed.
2. Periodically check all belts for wear. Replace any damaged or worn belts as needed.

5.6 Drive Belt Adjustment



WARNING! Do not for any reason adjust the drive belt with the motor running. Doing so may result in serious injury.

See Table 5-2. Check the drive belt tension after the first 20 hours, and every 50 hours thereafter. See the table below for drive belt tension specifications for your resaw.

Motor	Belt Tension
E11, E15	17mm (0.67") deflection with 10 kG of deflection force

TABLE 5-2

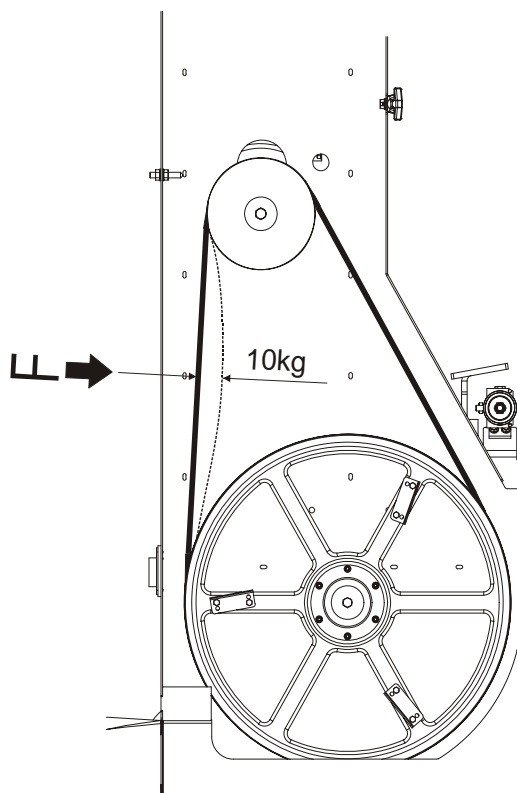

FIG. 5-3

To adjust the drive belt tension:

1. Loosen the four motor mounting bolts (see Figure 3-3).
2. Loosen the lock nuts on the adjustment bolts. Using the adjustment bolts move the motor mounting plate down to tension the drive belt, move the motor plate up to loosen the belt. Next tighten the lock nuts. **NOTE:** Be sure to adjust the bolts evenly so the motor remains in alignment.

3. Tighten the four motor mounting bolts.

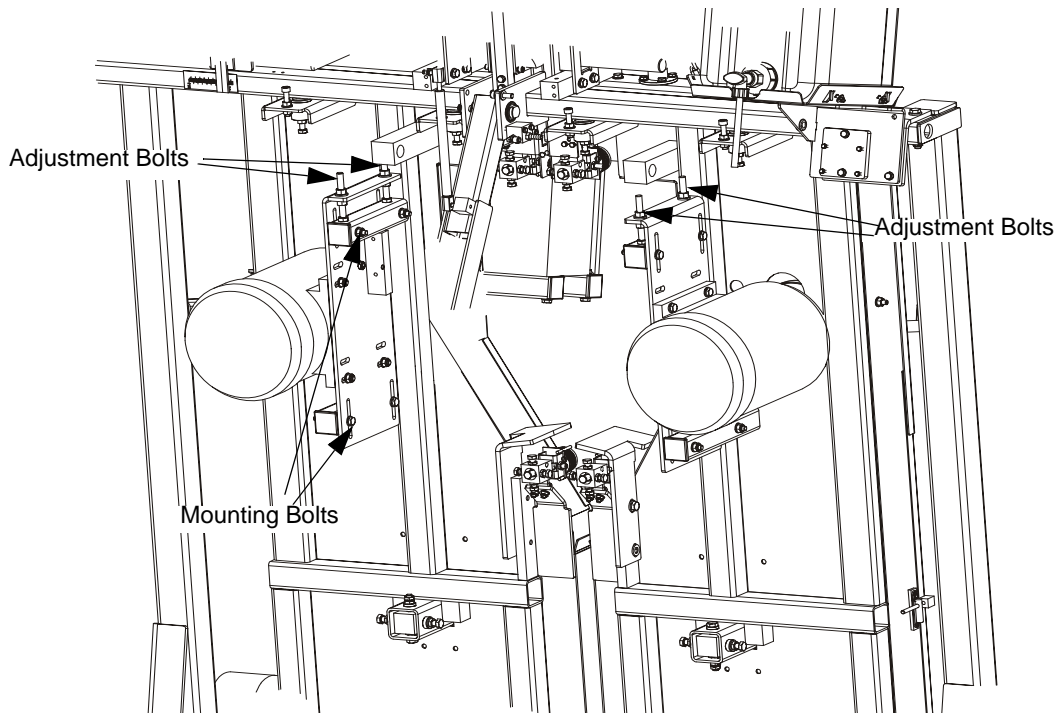

FIG. 5-3



Periodically check the belt for wear. Replace if damaged or worn.

See Figure 5-4. Keep the motor and drive pulleys aligned to prevent premature belt wear. To align the motor pulley to the drive pulley, loosen the mounting bolts on the motor plate and slide the motor plate in or out until it is in line with the drive pulley. After performing the alignment, make sure the

drive belt tension has not been changed.

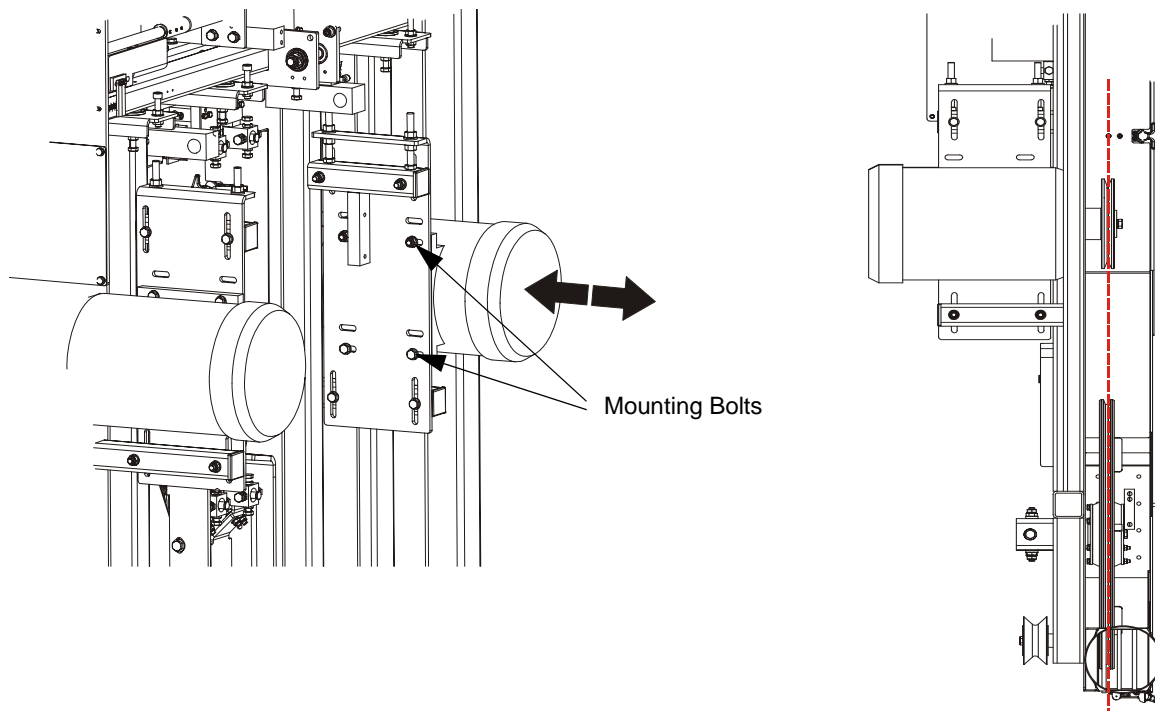

FIG. 5-4

5.7 Feed Track Chain Tension

See Figure 5-5. If necessary, use the adjustment bolts shown below to adjust the feed track chain tension. The chain should lay freely on the upper and lower bars.

CAUTION! Do not over-tension the TVS tables, Log Deck and Transfer Table chains. Over-tensioning may lead to early failure of the gear, bearings, rollers and chains.

See Figure 5-6. Infeed table chain tension adjustments. The bolts must be adjusted evenly.

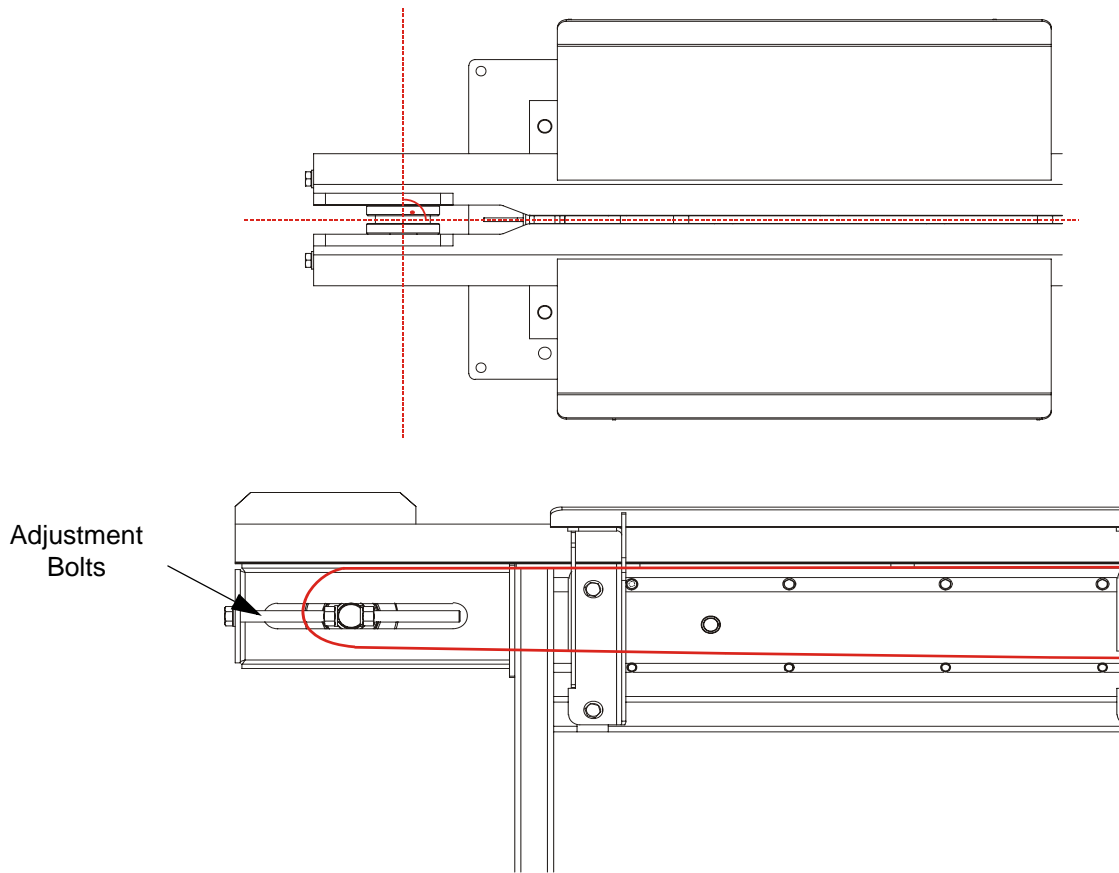

FIG. 5-6

See Figure 5-7. Incline Log Deck chain tension adjustments

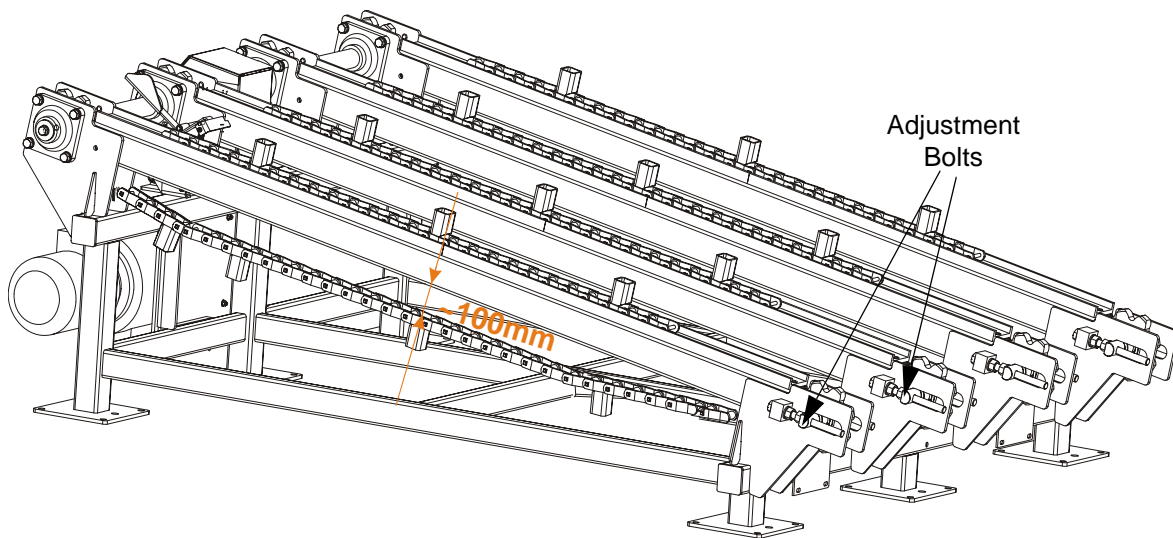

FIG. 5-7

See Figure 5-8. Adjust Cross Transfer Deck chain tension so that the chain lay freely, on the supporting roller.

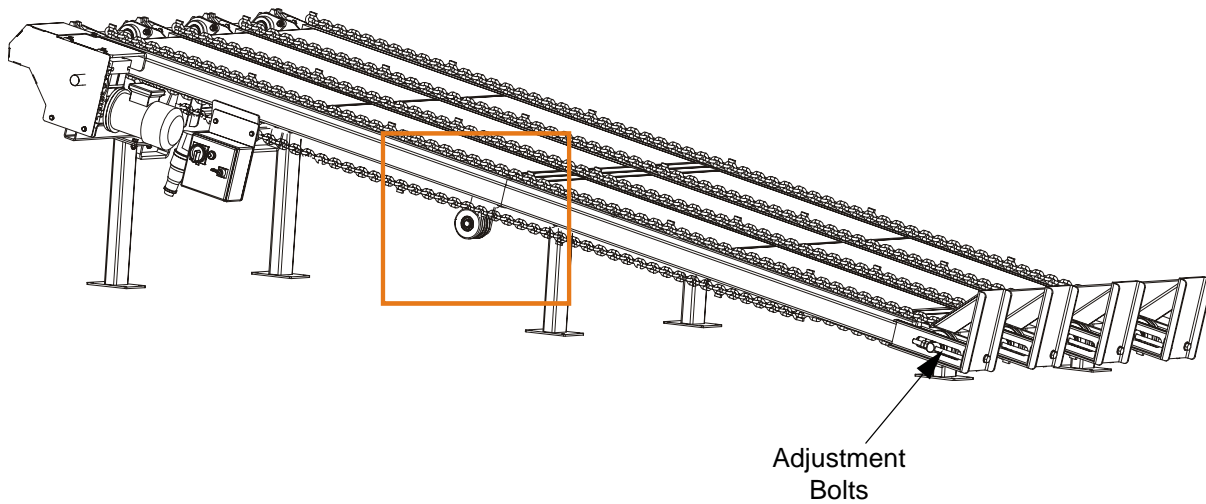

FIG. 5-8

5.8 Log Deck and Transfer Deck Drive Chain Tension

Check the drive chains for tension every 40 hours of operation and tension as necessary. The chains should have approximately 15mm (0,59”) of slack.

See Figure 5-9. Loosen mounting bolts and slide the motor with mounting plate in direction shown by arrows.

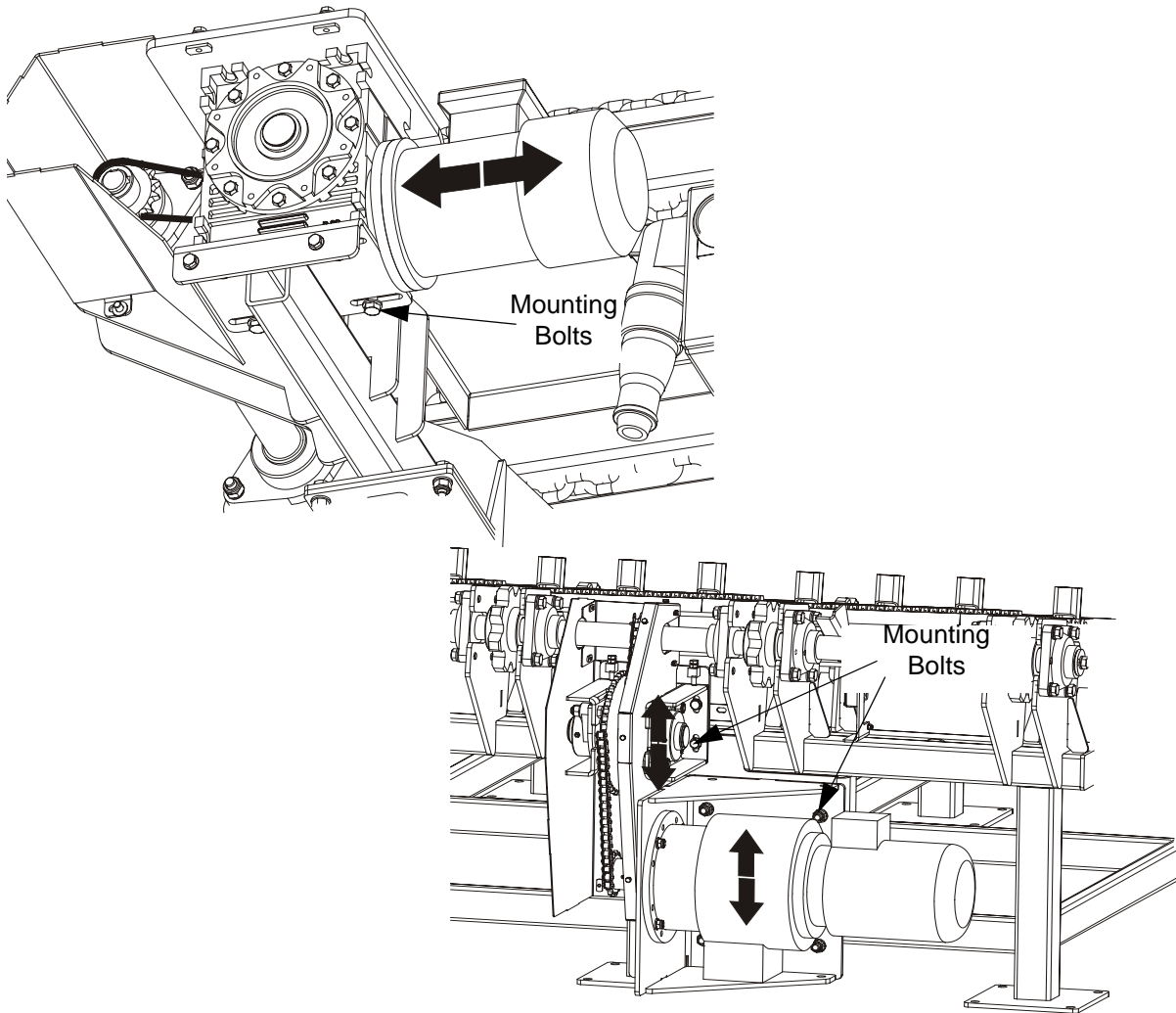

FIG. 5-9

5.9 Lube Mizer System

1. Clean the lube filter as needed.

To clean,

- Make sure the lube control is in the OFF position and the lube bottle valve is closed all the way.
- Unscrew the filter reservoir and flush with water.
- Remove the cylindrical mesh filter and gently flush with water.
- Replace the filter and reservoir.

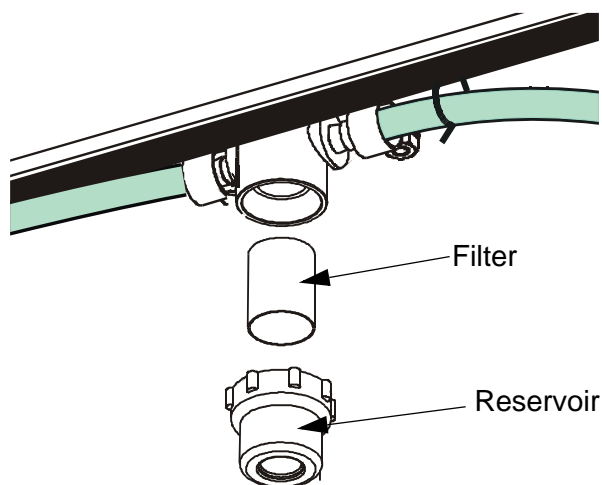

FIG. 5-9

2. Periodically check lube hoses and lines for buildup. Remove and flush with water as needed.
3. Periodically check the blade guide bracket nozzles for buildup. Remove and flush with water as needed.

5.10 Safety Devices Inspection

TVS – Safety Devices Inspection

Safety devices on the TVS machine which must be checked before every shift:

- E-STOP circuit inspection - control box
- E-STOP circuit inspection - table
- Safety switch circuit inspection - control box arm 1
- Safety switch circuit inspection - control box arm 2
- Saw heads minimum distance safety switch circuit inspection
- Saw heads maximum distance safety switch circuit inspection
- Motor brake and its circuit inspection

1. E-STOP circuit inspection - control box

- Turn on the blade motor;
- Press the E-STOP button located on the control box. Blade motor should be stopped. Blade motor shouldn't start until the E-STOP button is released.

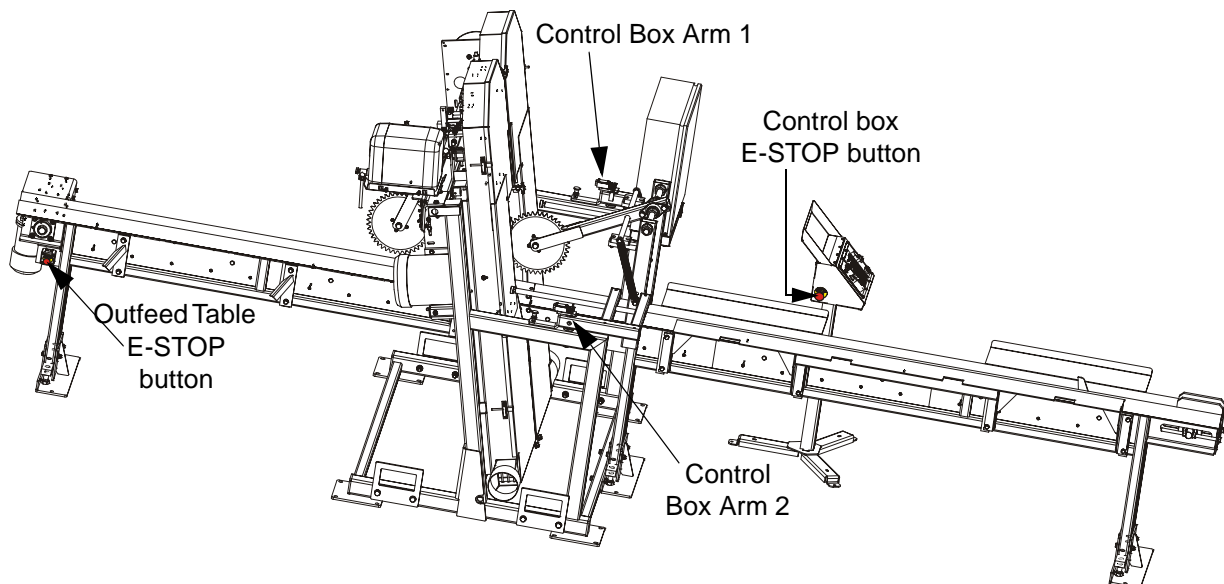

OBR. 5-10

2. E-STOP circuit inspection - outfeed table

- Turn on the blade motor;
- Push the E-STOP button located on the outfeed table. Blade motor should be stopped. Blade motor shouldn't start until the E-STOP button is released.

3. Limit switch circuit inspection - control box arm #1

- Turn on the blade motor;
- Open blade housing cover #1;
- Blade motor should be stopped;
- Try to start motor. The blade motor should remain stopped;
- Close blade housing cover #1;
- Blade motor should remain stopped;

4. Limit switch circuit inspection - control box arm #2

- Turn on the blade motor;
- Open blade housing cover #2;
- Blade motor should be stopped;
- Try to start motor. The blade motor should remain stopped;
- Close blade housing cover #2;
- Blade motor should remain stopped;

5. Saw heads minimum distance safety switch circuit inspection

- Push and hold LEFT button on the control box, till the power feed will automatically stop.
- Repeat for the LEFT button located on SETWORK.

5. Saw heads maximum distance safety switch circuit inspection

- Push and hold RIGHT button on the control box, till the power feed will automatically turn off.
- Repeat for the RIGHT button located on SETWORK.

6. Motor brake and its circuit inspection

- Turn on the blade motor. Stop the motor using STOP button. Measure the breaking time.

- Turn on the blade motor. Stop the motor by switching the to “0” position. Measure the breaking time.
- Turn on the blade motor. Stop the motor by switching the to “H” position. Measure the breaking time.
- Braking time should always be shorter then 10 seconds. If the braking time is longer it is necessary to adjust or replace motor disc brake. See your motor option manual.

SECTION 6 ALIGNMENT

The Wood-Mizer resaw is factory aligned. This section includes routine alignment instructions and also how to realign the resaw completely. Be scrupulous when performing all alignment steps as resaw alignment determines the accuracy of your cuts. The routine alignment procedure should be performed approximately every 1500 hours of operation. Complete alignment should be performed with the first resaw setup or after general repairs.

6.1 Routine Alignment Procedure

6.1.1 Blade Installation And Tracking

See Figure 6-1. Install a blades and apply the proper tension. [See Section 2.5.](#)

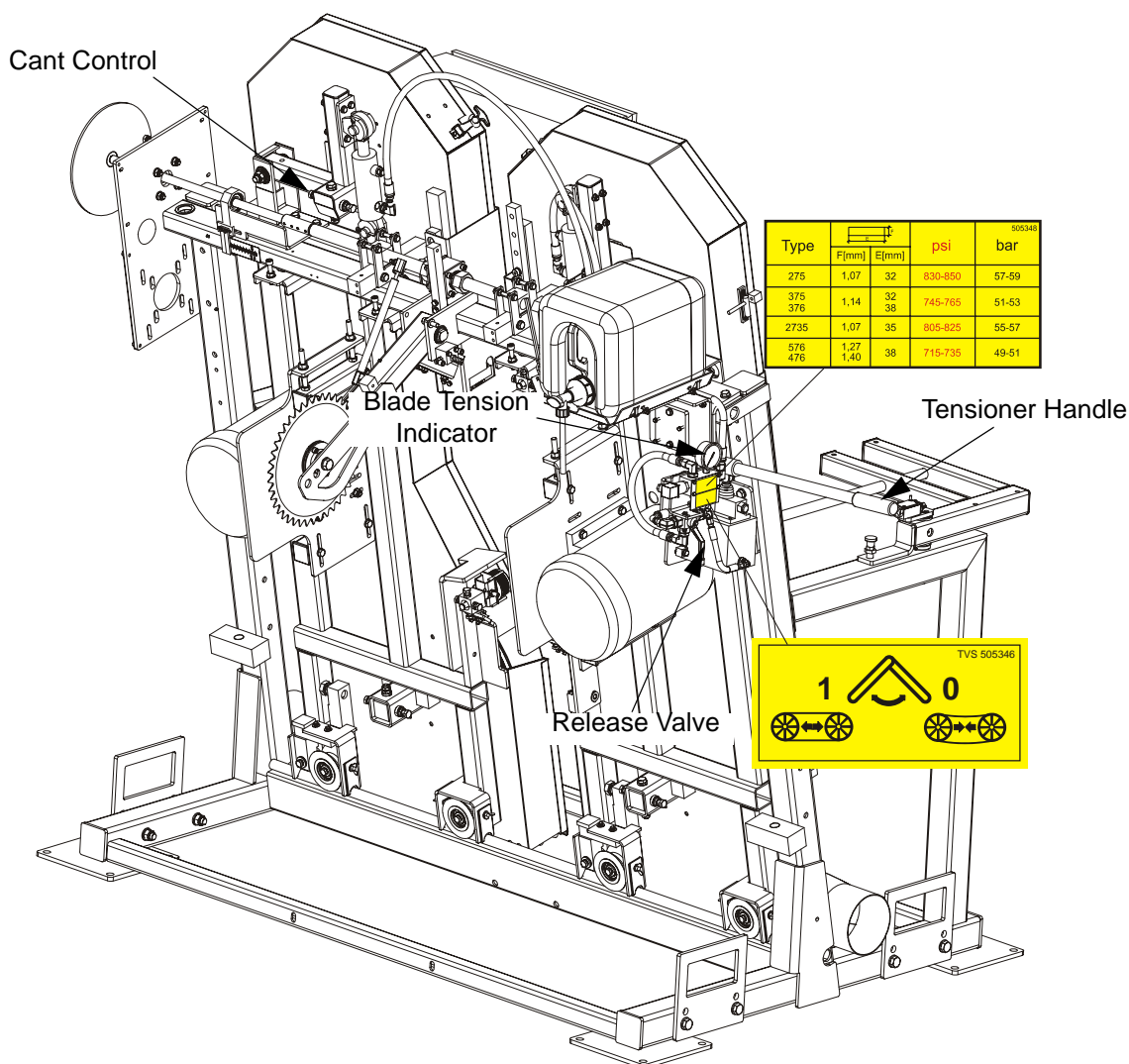

FIG. 6-1

1. Turn the key switch to the "H" position.

(H)

2. Open the blade housing covers.
3. Manually spin one of the blade wheels until the blade positions itself on the wheels.

See Figure 6-2. The blade wheels should be adjusted so that the gullet of 1 1/4" blades rides 3.0 mm (0.12") out from the front edge of the wheels (± 1.0 mm [0.04"]). The gullet of 1 1/2" blades should ride 4.5 mm (0.18") from the front edge of the wheels (± 1.0 mm [0.04"]). Do not let the teeth ride on the belt.

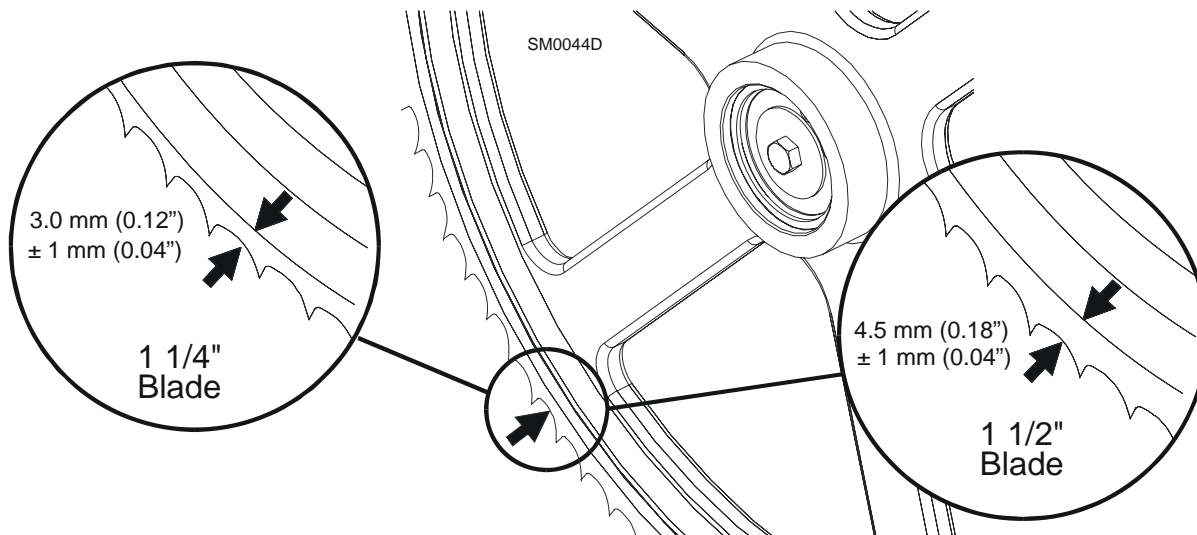

FIG. 6-2

To adjust where the blade travels on the idle-side blade wheel, use the cant control shown in **Figure 6-1**.

To move the blade out on the blade wheel, turn the cant adjustment bolt clockwise. To move the blade in on the blade wheel, turn the bolt counterclockwise.

Some adjustment in blade tension may be needed to compensate for adjustments made with the cant control.

Adjustment with the cant control is usually all that is required to track the blade properly on both blade wheels. The drive-side blade wheel will usually not have to be adjusted. If necessary, the drive-side wheel can be adjusted as follows:

Locate the adjusting bolt with lock nuts located on the drive-side of the cutting head. Turn the bolt clockwise to move the blade out on the wheel, turn it counterclockwise to move the blade in on the blade wheel. Make sure to tighten the lock nuts when adjustment is complete.

6.1.2 Blade Wheel Alignment

The blade wheels should be adjusted so they are level in the vertical and horizontal planes. If the blade wheels are tilted vertically, the blade will want to move in the tilted direction. If the blade wheels are tilted horizontally, the blade will not track properly on the wheels. The blade guide rollers should not touch and deflect the blade when adjusting the blade wheels.

1. Use the blade guide alignment tools to check the vertical alignment of each blade wheel. Attach the tools to the blade near the lower blade guide mounts as shown. Be sure the tools do not rest on a tooth or burr, and are lying flat against the blades.

See Figure 6-3.

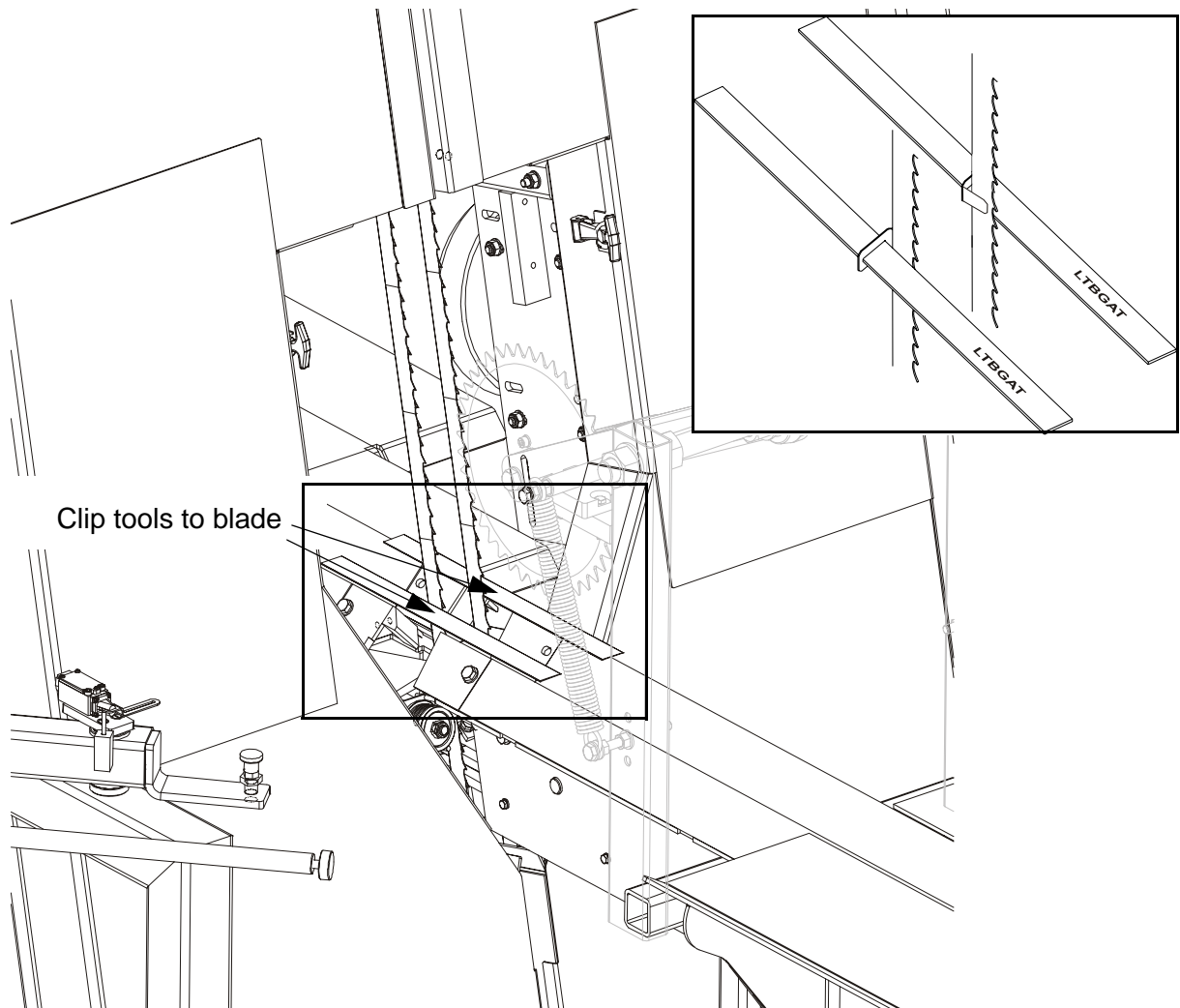

FIG. 6-3

2. Mount the alignment brackets to infeed and outfeed tables. Attach the rope to the lower holes of the alignment bracket as shown below.

See Figure 6-4.

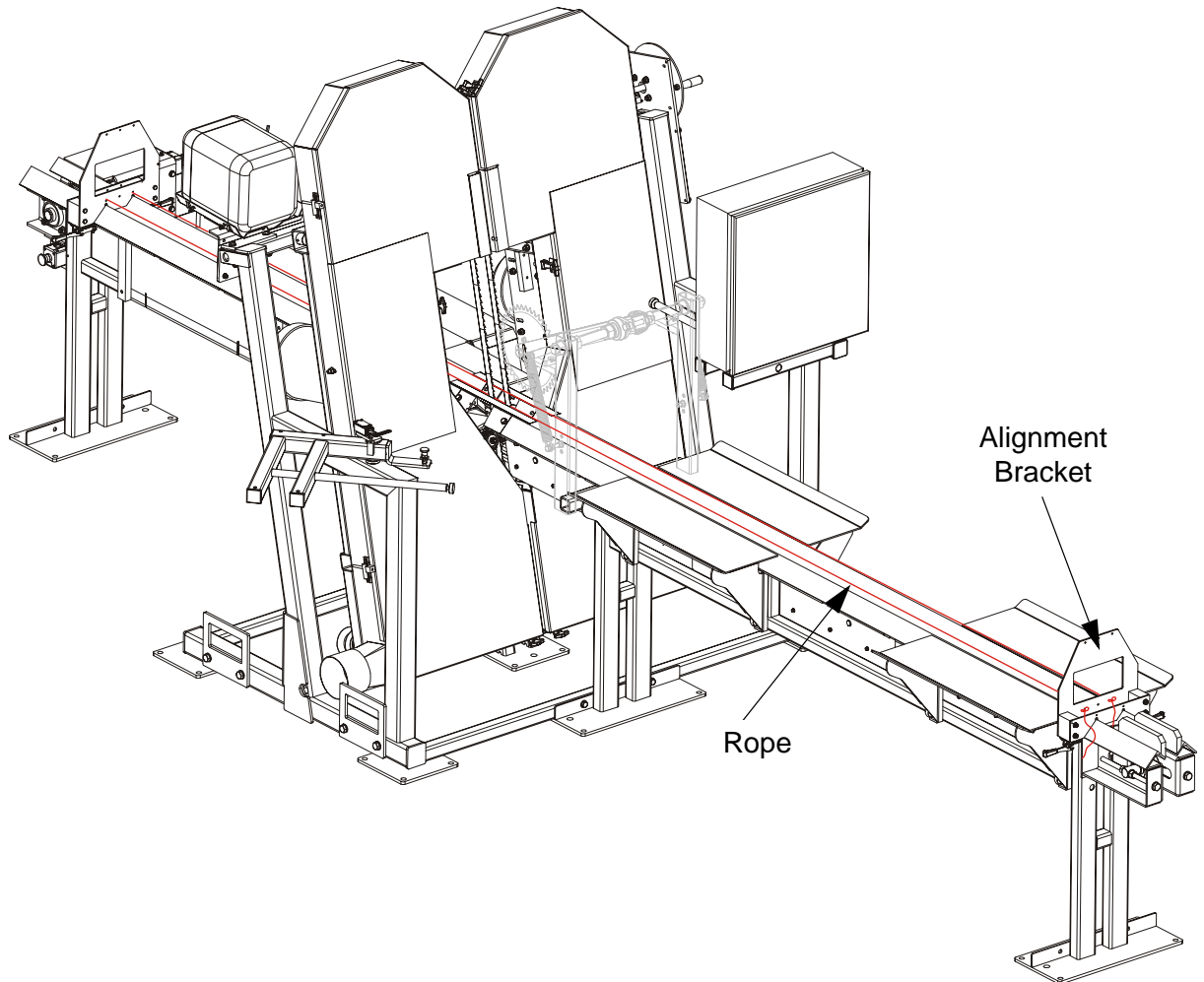

FIG. 6-4

3. Mount the alignment brackets to infeed and outfeed tables. Attach the rope to the lower or upper holes of the alignment bracket. Measure the distance from the rope to the infeed and outfeed tables in places shown below. Dimensions marked A, B and C must be equal. If they are not, use the tables legs adjustment bolts to correct it.

See Figure 6-5.

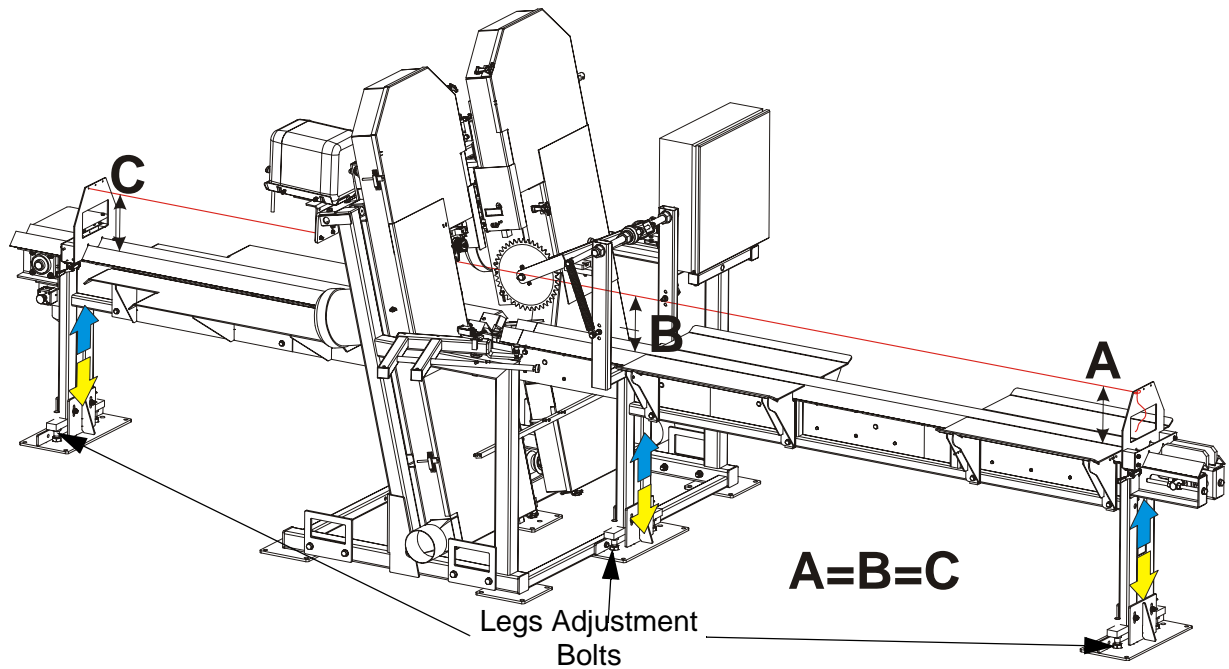

FIG. 6-5

4. Check if the ropes are aligned with top edges of the infeed and outfeed tables. Move the appropriate table end if necessary.

See Figure 6-6.

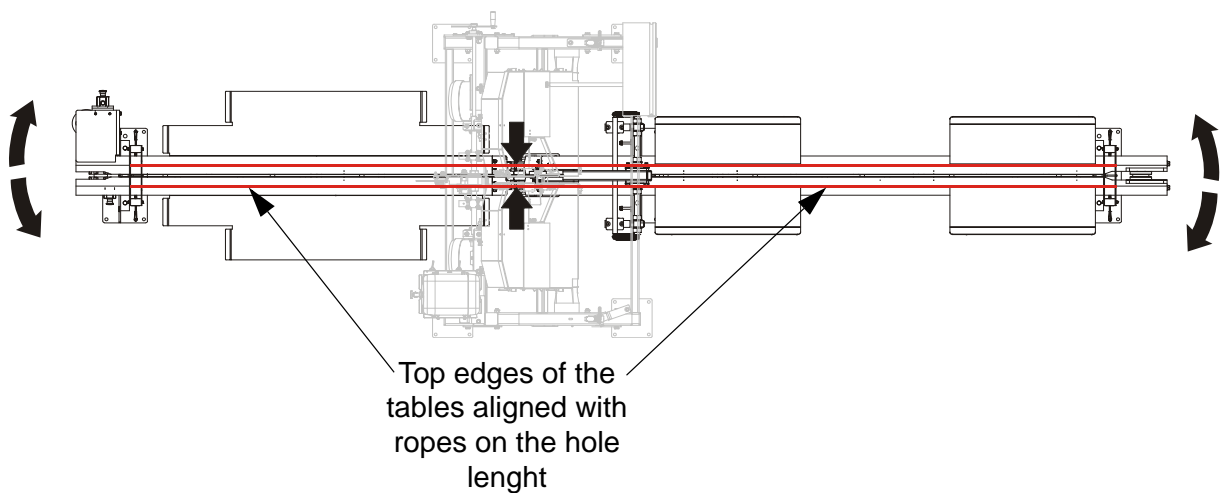

FIG. 6-6

5. Measure the distance from the edge of the tool to the rope. The distances marked A, B, C and D must be equal. If the measurements are different, use the drive side blade wheel adjustment bolts to correct its alignment.



IMPORTANT! Before adjusting the drive side wheel, loosen the drive belt. [See Section 5.6.](#)

See Figure 6-7.

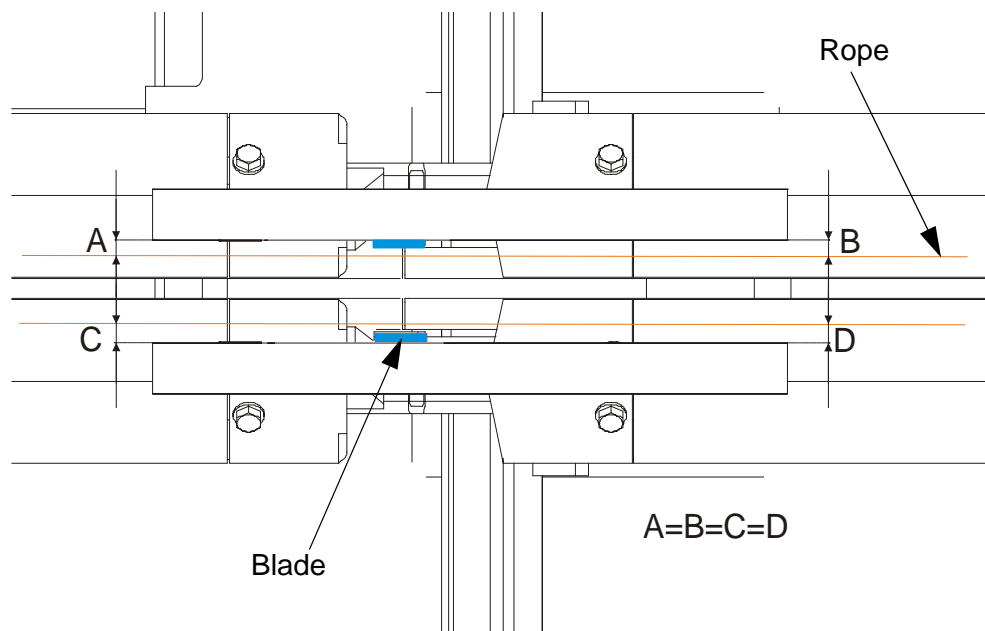

FIG. 6-7

See Figure 6-8. Loosen the lock nuts on the horizontal plane adjustment bolt. Next, use the vertical plane adjustment bolts to adjust the drive wheel so that the adjustment tool would be parallel to the

6

ALIGNMENT

Blade Wheel Alignment

rope.

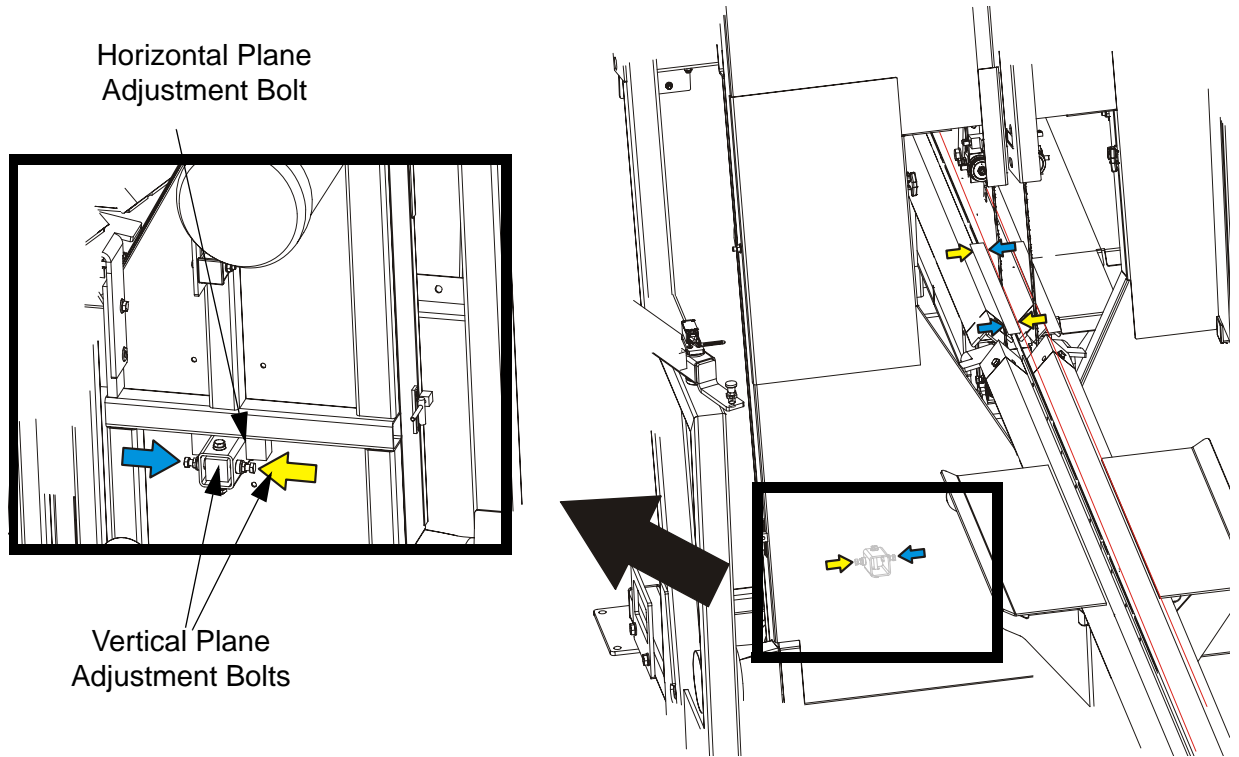

FIG. 6-8

6. Attach the rope to the upper holes of the alignment bracket as shown below. Next move the alignment tools up, at the height of the ropes. Use the idle side wheel adjustment bolts in vertical plane to correct its alignment. See the pictures below.

See Figure 6-9.

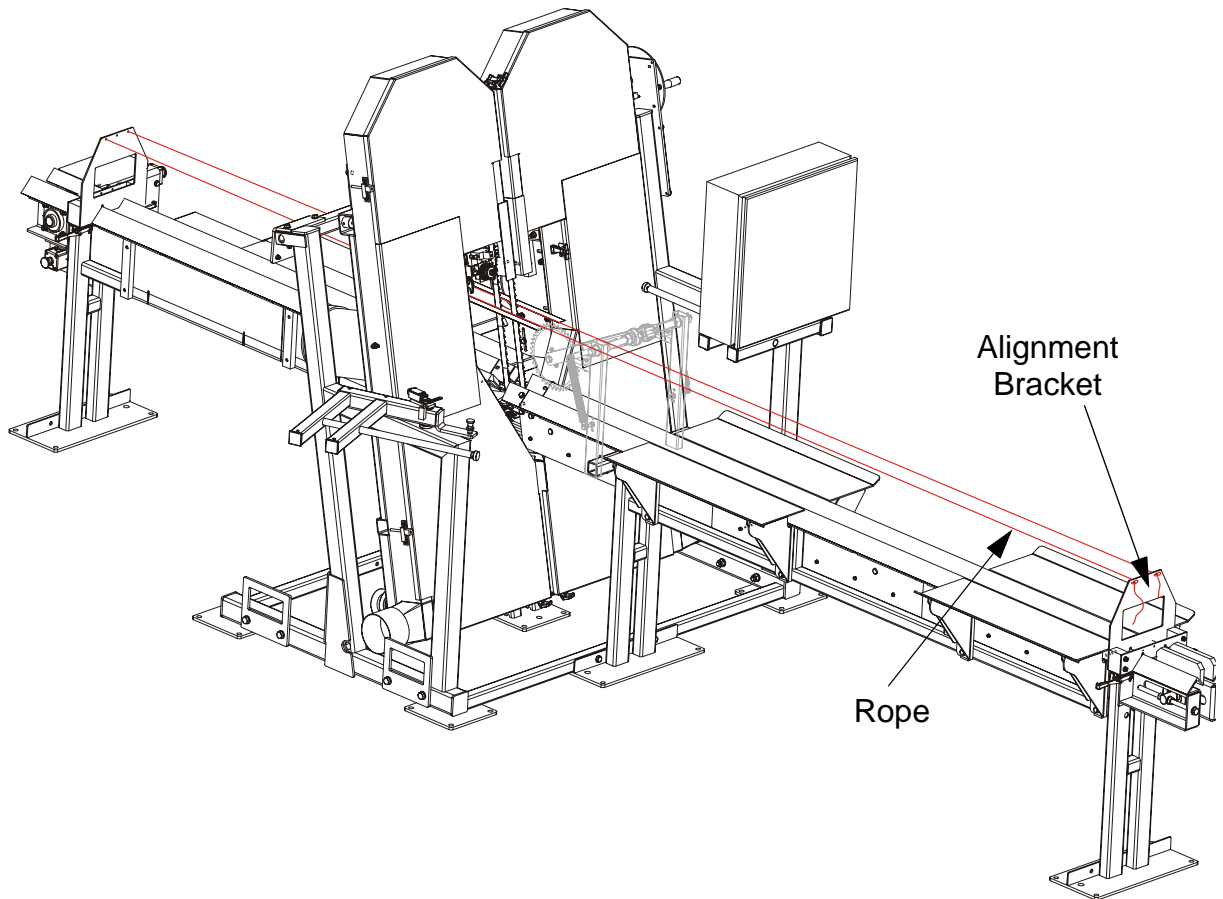

FIG. 6-9

See Figure 6-10. Loosen the lock nuts on the horizontal plane adjustment bolt. Next, use the vertical plane adjustment bolts to adjust the idle wheel so that the adjustment tool would be parallel to the

rope.

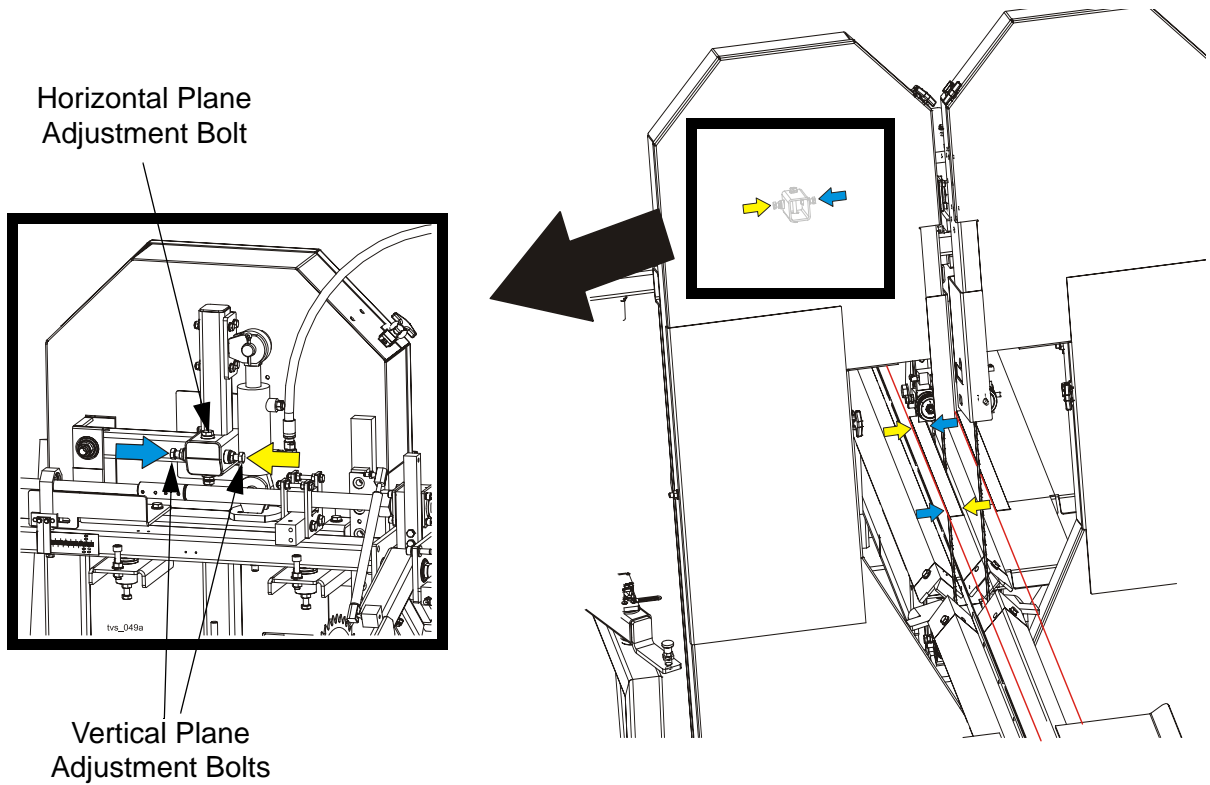

FIG. 6-10

7. Check the position of the blade on the idle-side blade wheel.

See Figure 6-11. The vertical tilt of the blade wheel should be adjusted so that the gullet of 1-1/4" blade is 3.0 mm (0.12") out from the front edge of the wheel (± 1.0 mm [0.04"]).

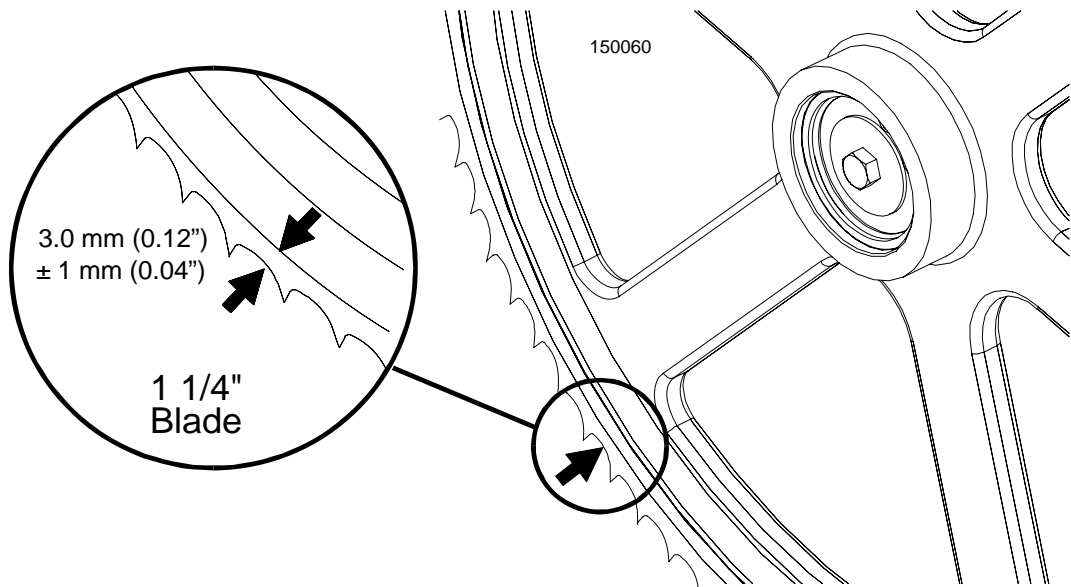

FIG. 6-11

See Figure 6-12. Use the cant control adjustment to adjust the idle-side blade wheel. If the blade is too far forward on the wheel, turn the cant control counterclockwise. If it is too far back on the wheel, turn the cant control clockwise.

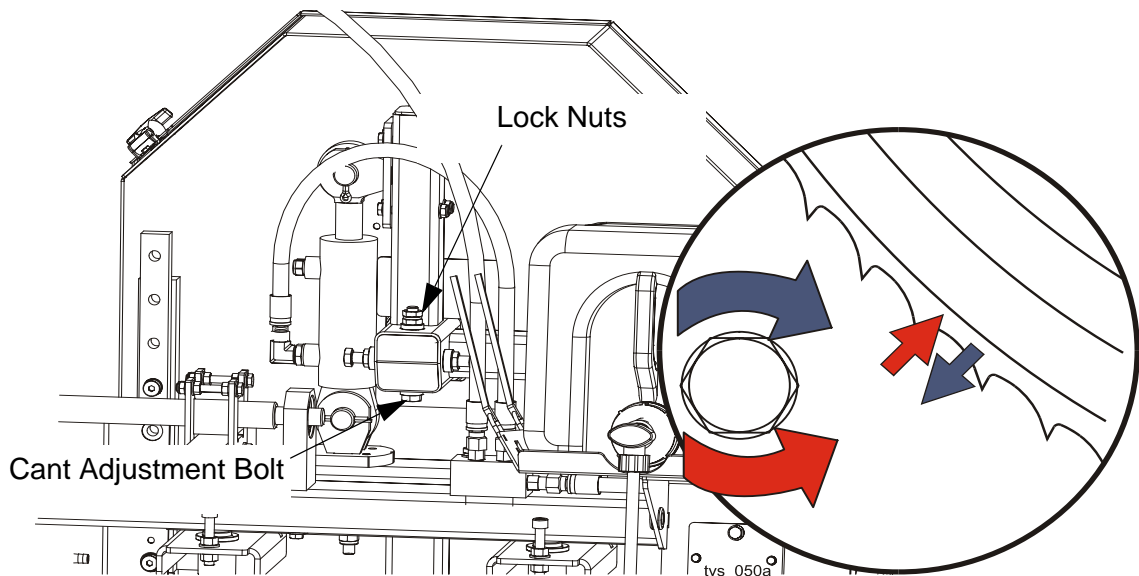

FIG. 6-12

6

ALIGNMENT

Aligning the Blade Guides

8. Check the position of the blade on the drive-side blade wheel. The blade should be positioned on the wheel as described for the idle-side blade wheel. Adjust the drive-side blade wheel if necessary.

See Figure 6-13. Use the cant control adjustment to adjust the drive-side blade wheel. If the blade is too far forward on the wheel, turn the cant control bolt clockwise. If it is too far back on the wheel, turn it counterclockwise.

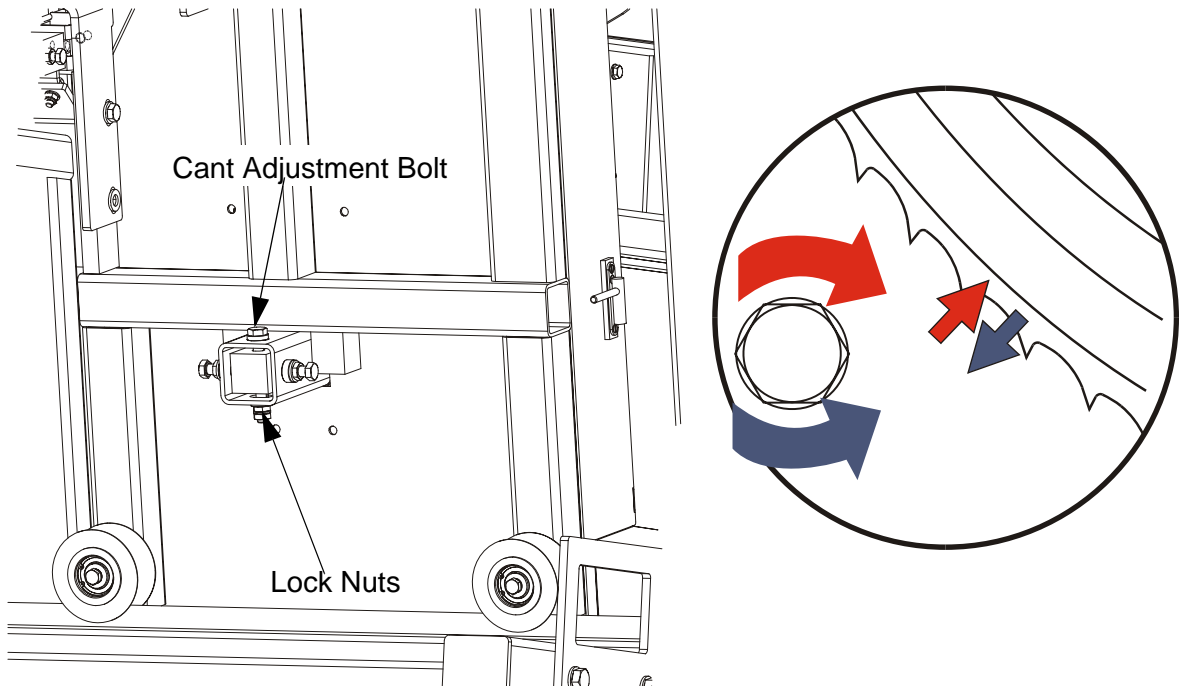

FIG. 6-13

6.1.3 Aligning the Blade Guides

[See Section 6.2.4.](#)

6.2 Complete Alignment Procedure

Perform all steps in this section to completely realign or align the resaw after first setup.

6.2.1 Blade Wheels Alignment

The blade wheels should be adjusted so they are level in the vertical and horizontal planes. If the blade wheels are tilted vertically, the blade will want to move in the tilted direction. If the blade wheels are tilted horizontally, the blade will not track properly on the wheels. The blade guide rollers should not touch and deflect the blade when adjusting the blade wheels.

1. Set the saw head distance at 100mm (3,937"). [See Section 2.8.](#)
2. Attach the blade wheels alignment tool (service no. 099330) to the lower blade wheels as shown on the picture below.

See Figure 6-14.

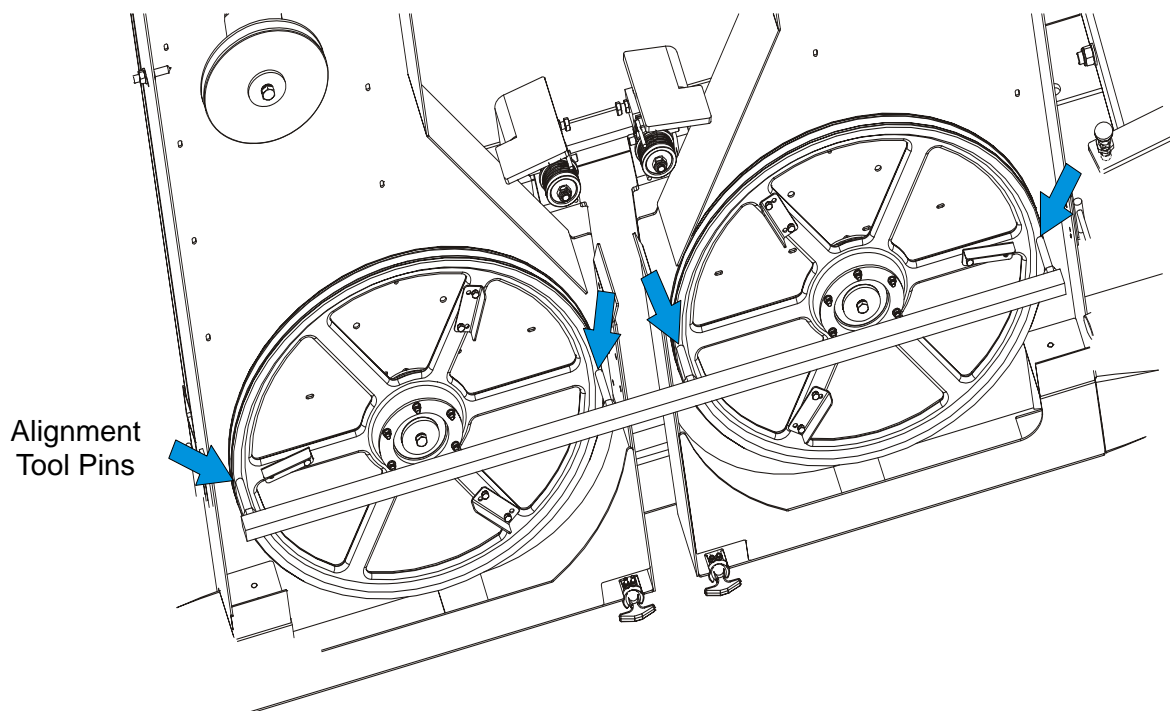

FIG. 6-14

All pins of the alignment tool must touch the blade wheels surface. If any of the pins does not touch the blade, use the vertical plane adjustment bolts to correct blade wheel alignment.

See Figure 6-15. Use the vertical plane adjustment bolts of the drive wheels, so that all the pins

6 ALIGNMENT

Blade Wheels Alignment

touch the blade wheels surface.

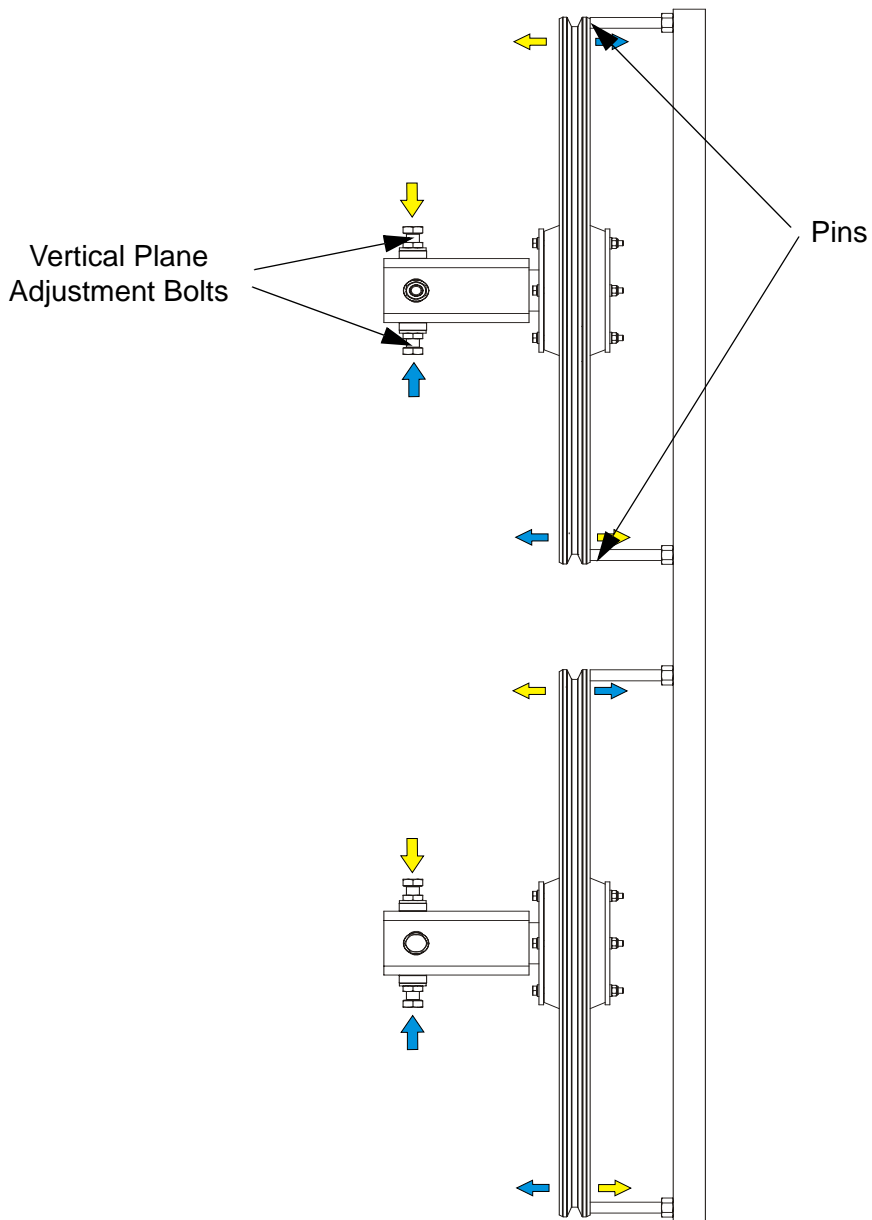

FIG. 6-15

3. Install a blades and apply the proper tension - [See Section 2.5](#).
4. Turn the key switch to the "H" position.

(H)

5. Manually spin the lower blade wheels. Observe how the blade rides on the blade wheels.

See Figure 6-16. The blade wheels should be adjusted so that the gullet of 1 1/4" blades rides 3.0 mm (0.12") out from the front edge of the wheels (± 1.0 mm[0.04"]).

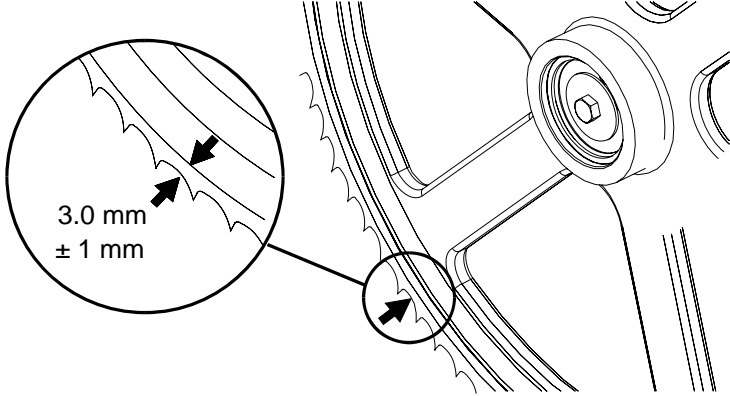

FIG. 6-16

6

ALIGNMENT

Blade Wheels Alignment

See Figure 6-17. Arrows show which bolts should be used to tilt the wheels in required direction.

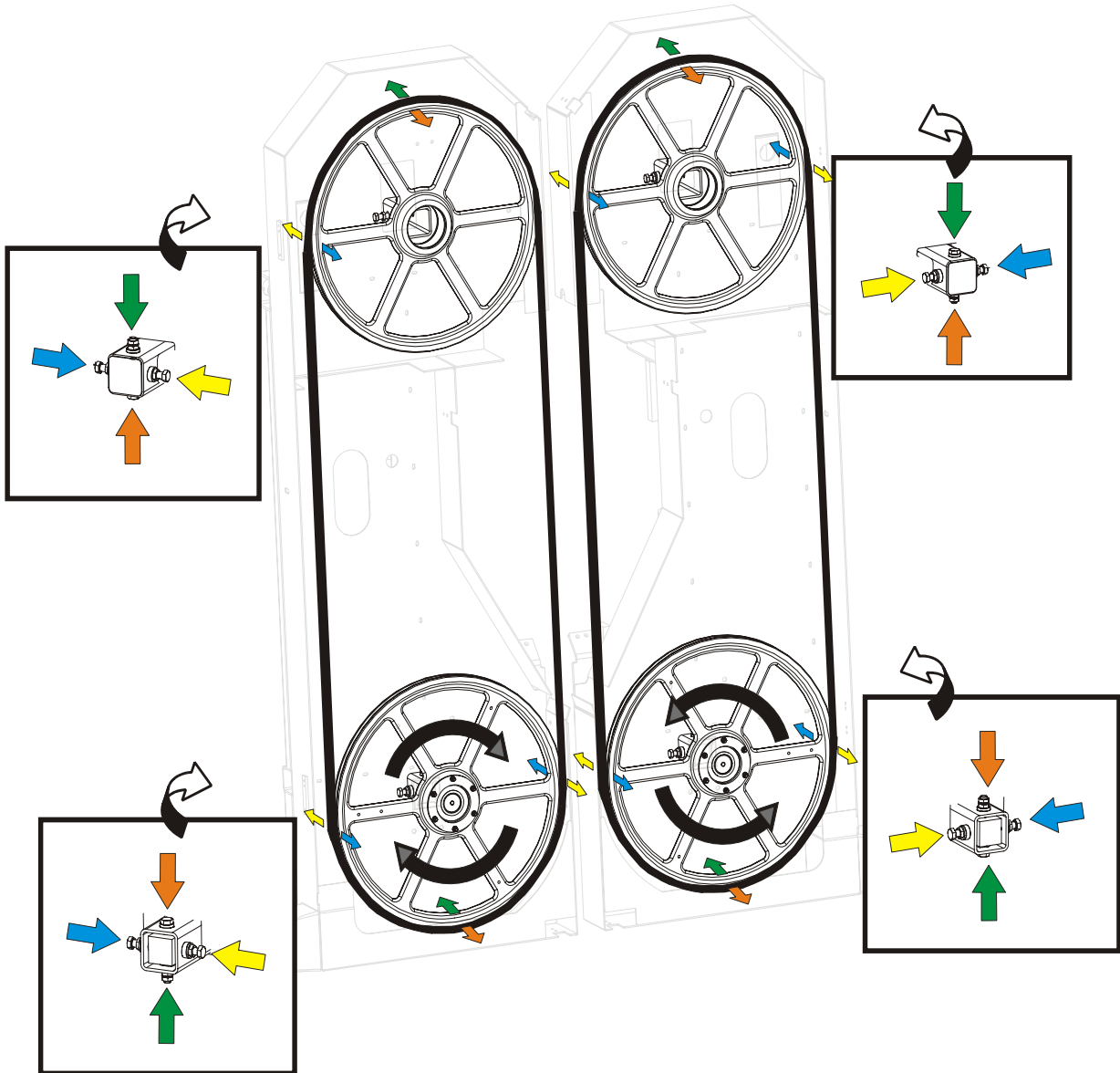

FIG. 6-17

6. Remove the blades from the blade wheels.

6.2.2 Saw Head Tilt Adjustment

The saw head blades should be perpendicular to the tables and parallel to each other.

First, set one of the blades so that it is perpendicular to the table and then set the other blade in relation to the first one. To do that, perform the following steps:

1. Make sure the rollers do not touch the blade. Set the blade perpendicularly to the table using a square and adjust using the adjustment bolt.

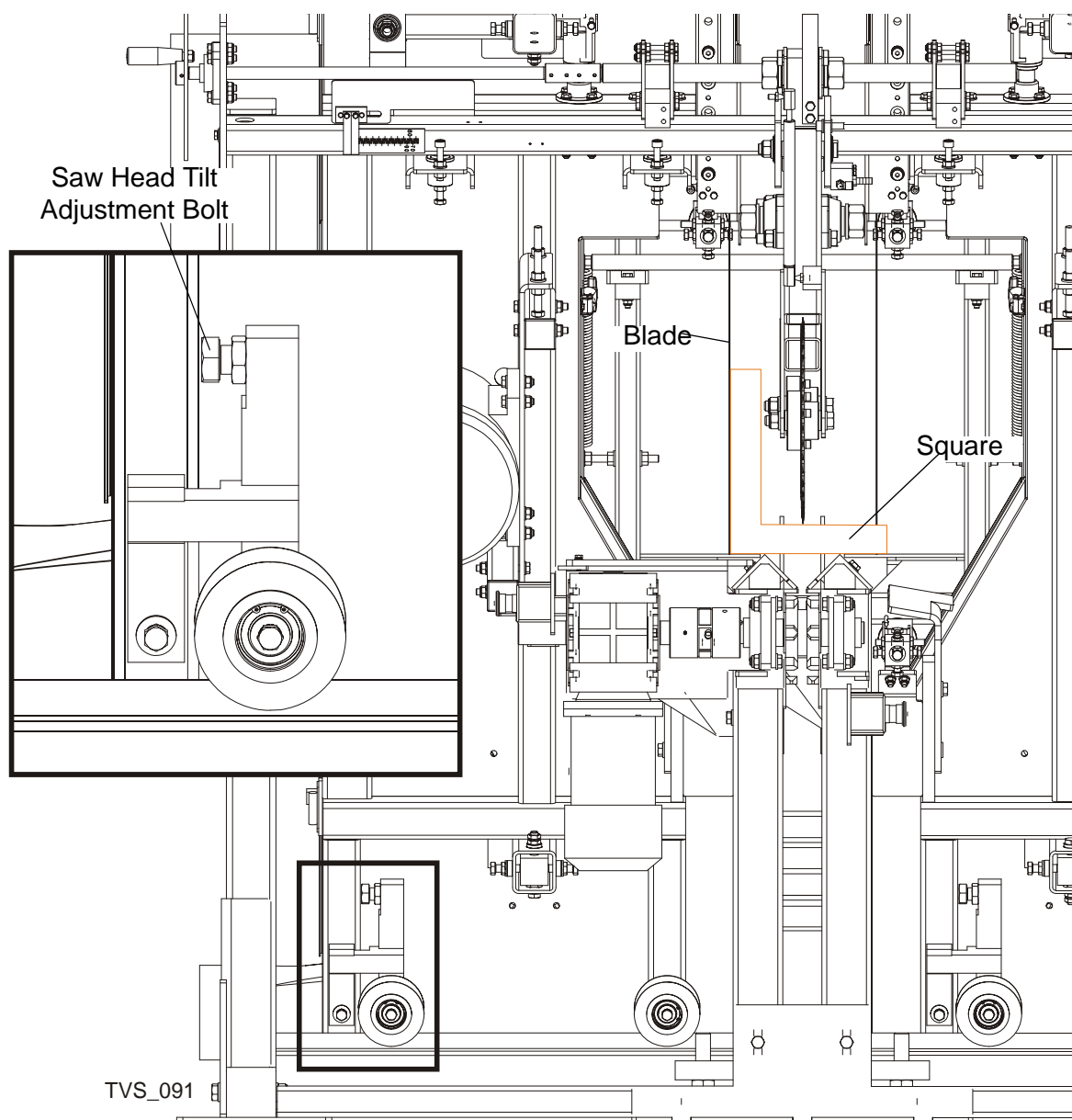

6

ALIGNMENT

Saw Head Tilt Adjustment

2. Measure distances between the blades at the lowest and the highest points. If the measurements are not the same, adjust the saw heads using the tilt adjustment bolts shown below.

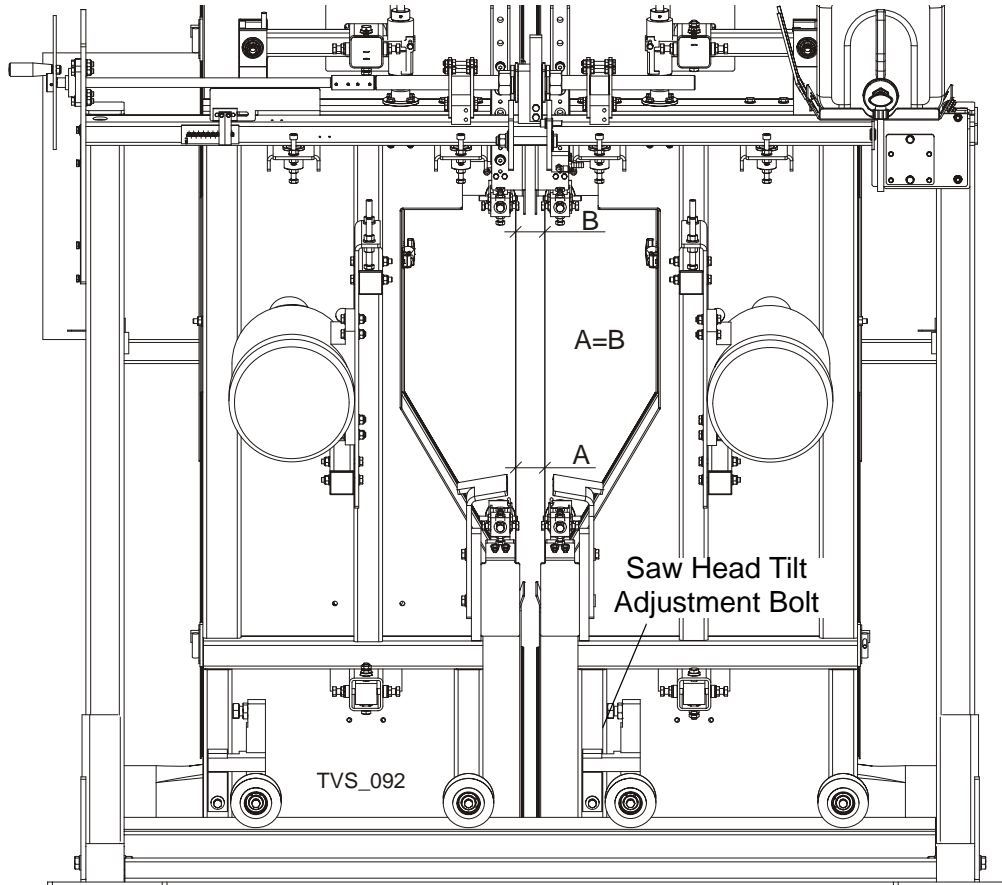

3. Use the square to check if the saw heads are perpendicular to the table. Adjust if necessary.

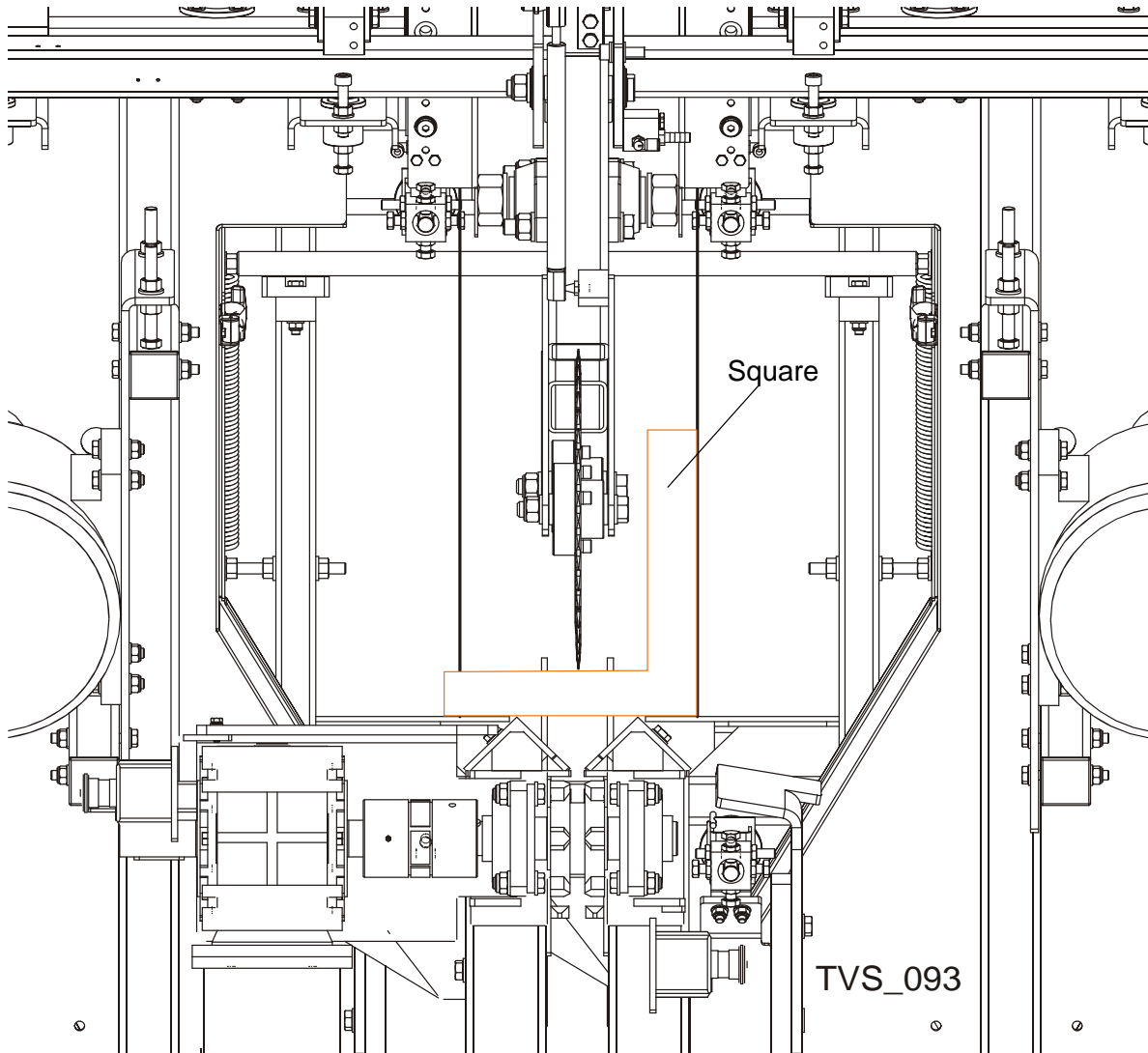

6.2.3 Installation of Tables

1. Mount the outfeed table.

See Figure 6-18. Move out the saw heads to the maximum width. Slide the front leg of the outfeed table under the TVS frame as shown. Next bolt the table with frame using the two M12x75 bolts and washers.

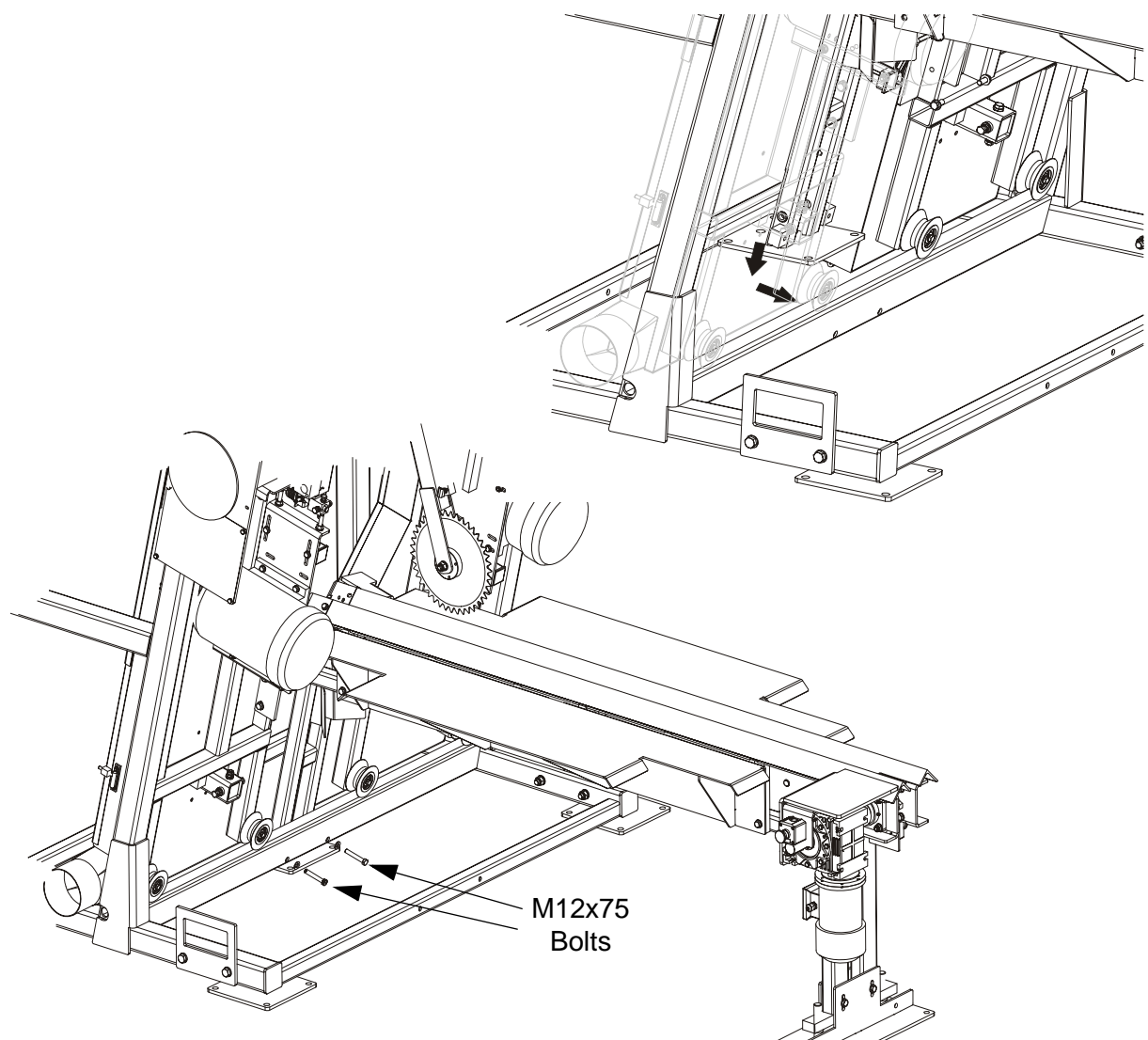

FIG. 6-18

2. Mount the infeed table.

See Figure 6-19. Attach the infeed table to the TVS frame. Use the mounting bar and M10x80 bolt to mount the infeed and outfeed tables together. Next bolt the infeed table with the TVS frame using the

two M12x75 bolts, washers and self-locking nuts.

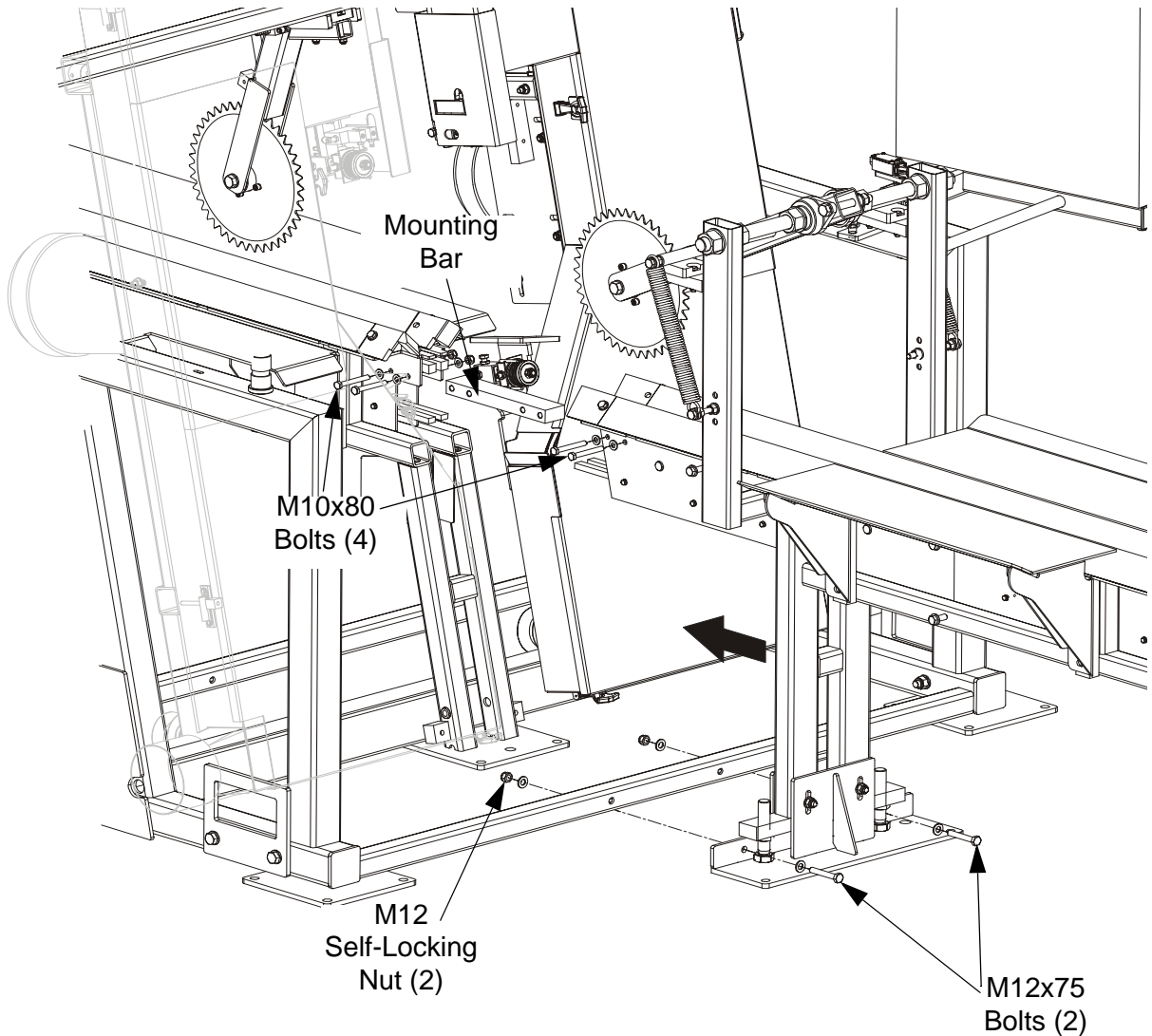

FIG. 6-19

- Place the level on the outfeed and infeed tables and check if they are level.

See Figure 6-20. Place the level in places shown below and check if the tables are level. If they need adjustment, use the appropriate adjustment bolts shown on picture. The front leg of the outfeed table

6

ALIGNMENT

Installation of Tables

is not adjustable.

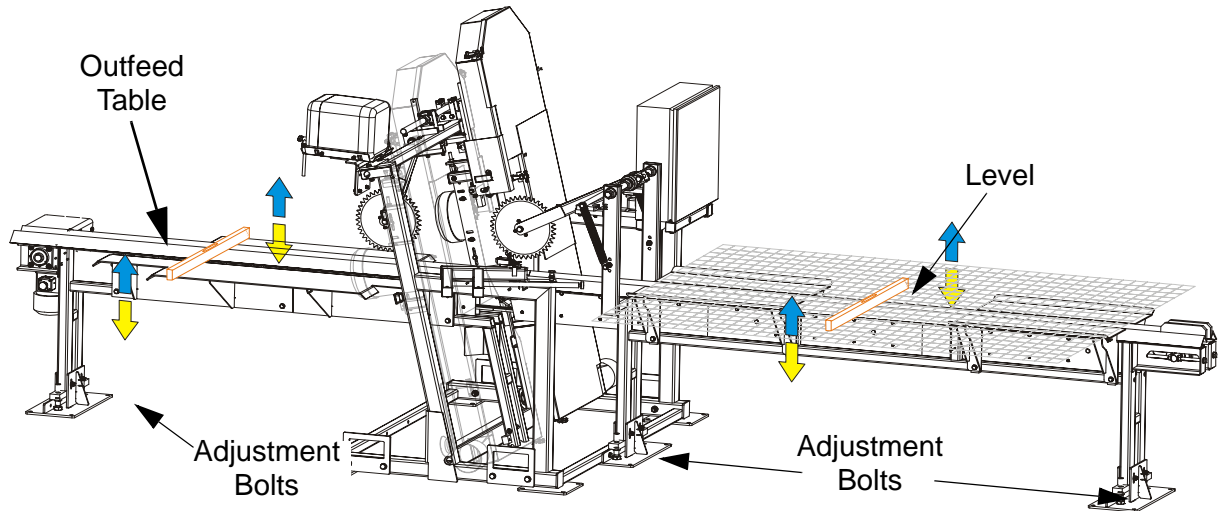

FIG. 6-20

4. Mount the alignment brackets to infeed and outfeed tables. Attach the rope to the lower or upper holes of the alignment bracket. Measure the distance from the rope to the infeed and outfeed tables in places shown below. Dimensions marked A, B and C must be equal. If they are not, use the tables legs adjustment bolts to correct it.

See Figure 6-21.

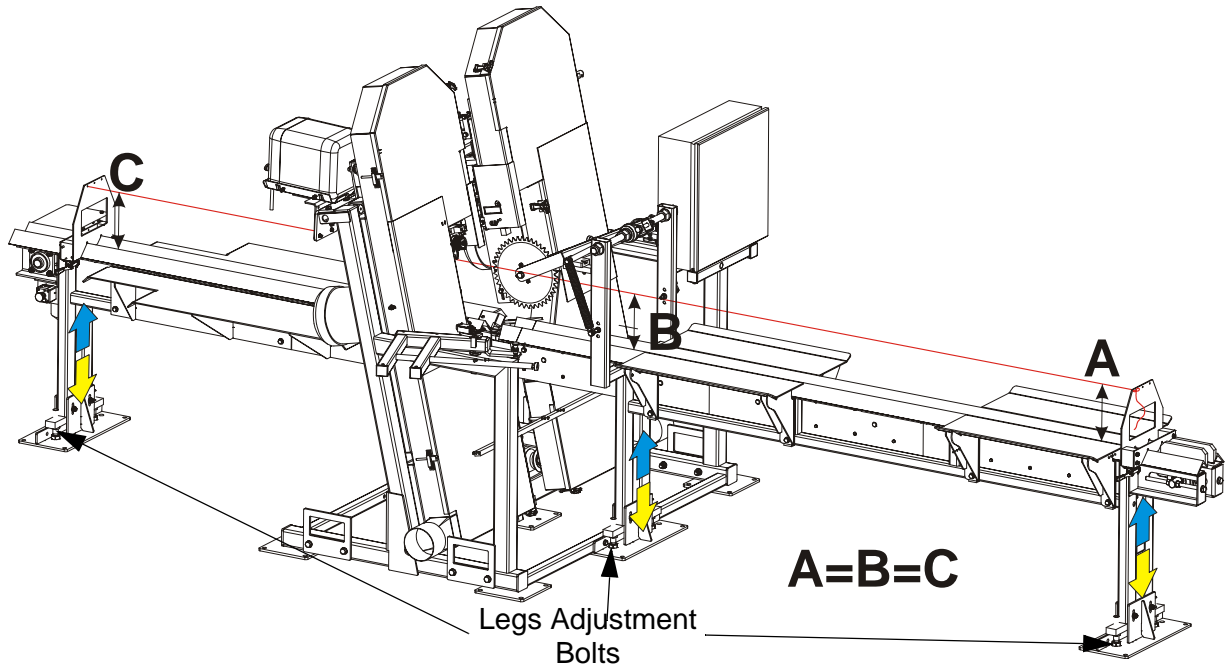

FIG. 6-21

5. Check if the ropes are aligned with top edges of the infeed and outfeed tables. Move the appropriate table end if necessary.

See Figure 6-22.

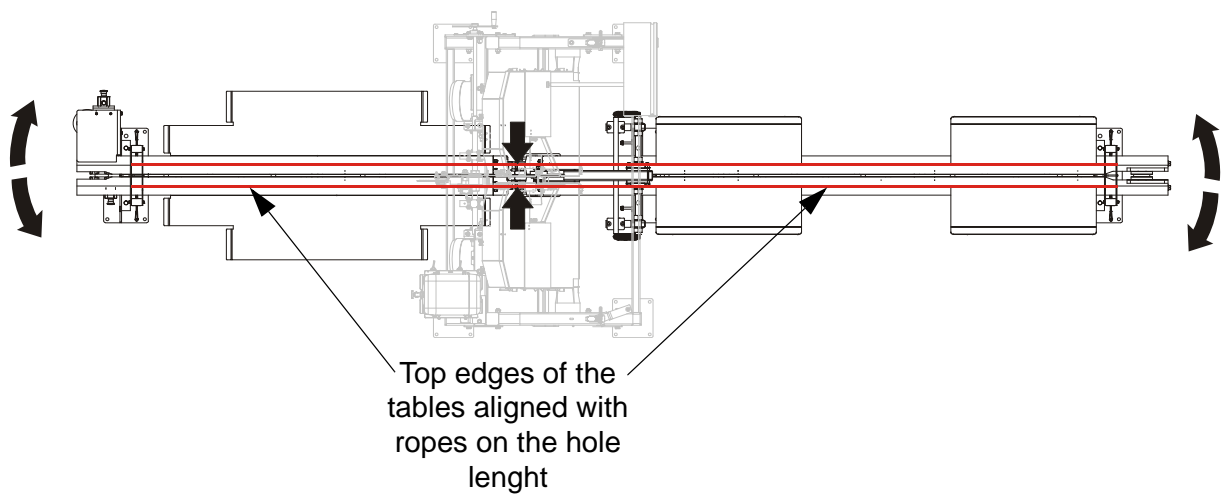

FIG. 6-22

6 ALIGNMENT

Installation of Tables

6. Install the blades and adjust the proper tension - [See Section 2.5](#)
7. Turn the key switch to the "H" position.

(H)

8. Using a square, check if the blades are perpendicular to the tables. If they are not, put a wedges under appropriate TVS frame legs.

See Figure 6-23.

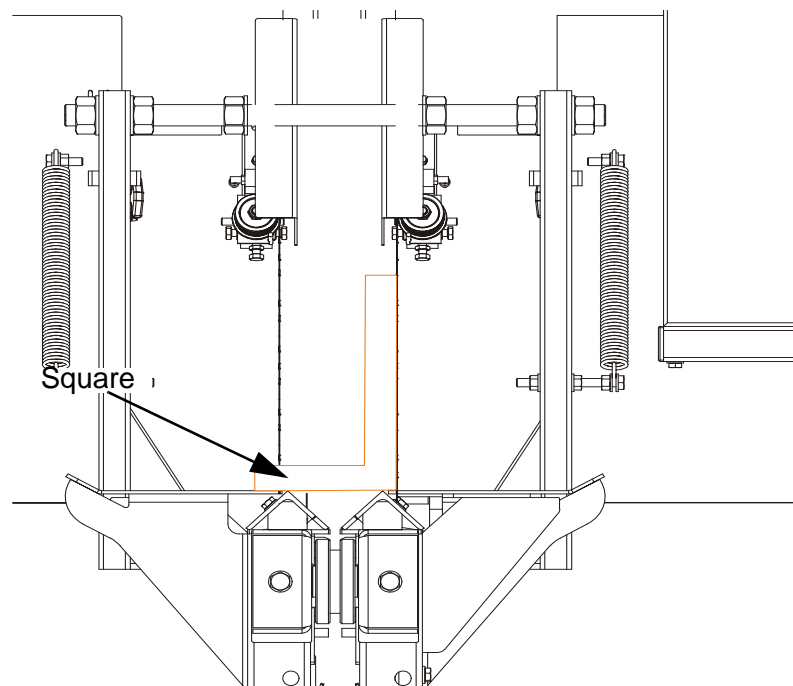

FIG. 6-23

9. Check if distance between blades and tables on the left and right saw heads is the same (saw heads centring).

See Figure 6-24. Set the saw head width to about 140mm (5.512"). Measure the distance from the blade on the left saw head to the left rope. Next measure the distance from the blade on the right saw head to the right rope. The measured distanced should be the same. If they are not, use the nuts on the saw head width adjustment screw and two #46 wrench (also available as WM part no.

099324-1) to move both saw heads left or right.

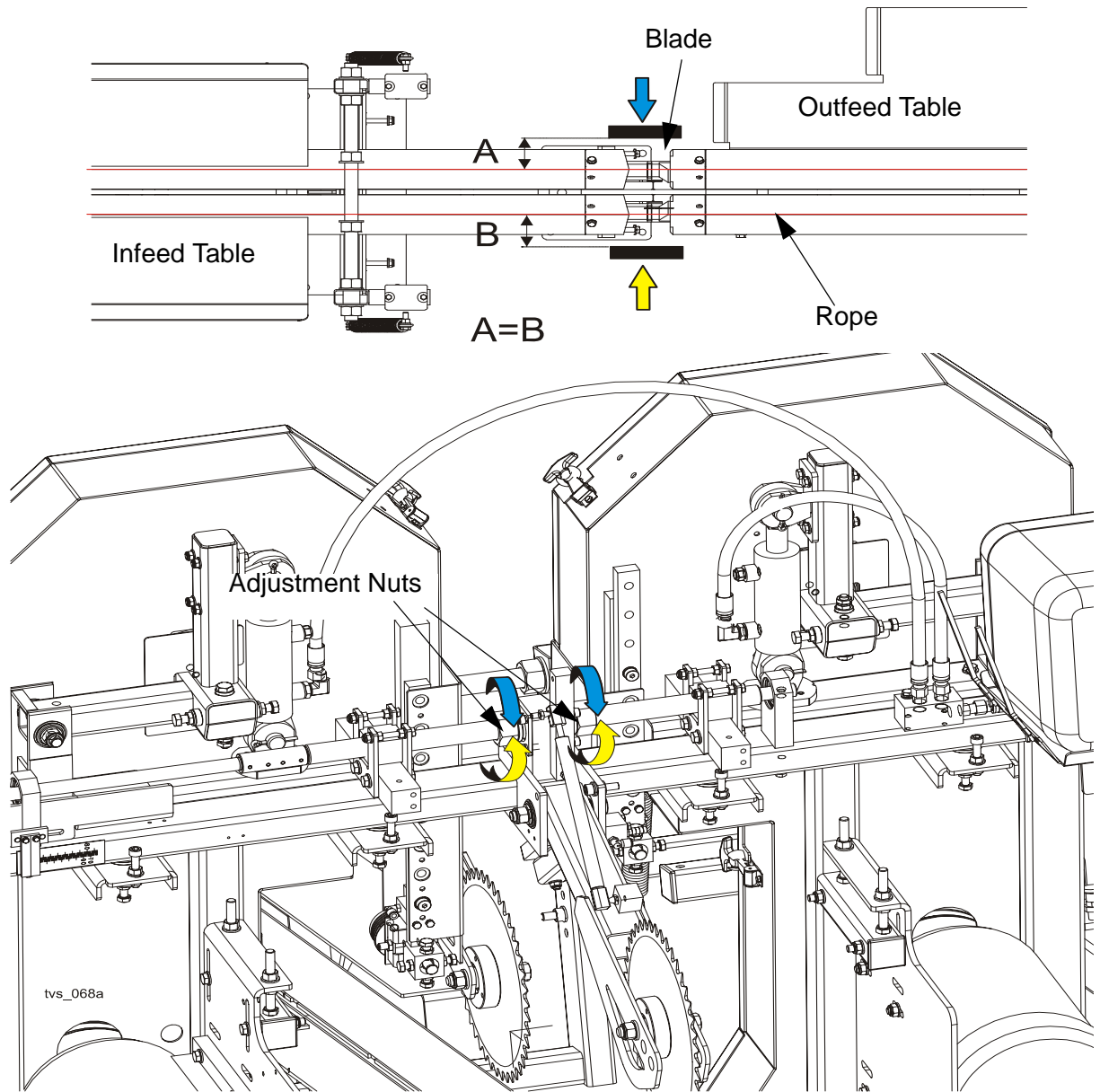

FIG. 6-24

6.2.4 Aligning the Blade Guides

Each Wood-Mizer resaw has two blade guide assemblies that help the blade maintain a straight cut. The two blade guide assemblies are positioned on the cutting head to guide the blade on each side of the material being cut.

One blade guide assembly is mounted in a stationary position on the drive side of the cutting head. This assembly is referred to as the "inner" blade guide assembly.

The other blade guide assembly is mounted on the idle side of the cutting head. It is referred to as the "outer" assembly and is adjustable for various widths of materials to be processed.

Blade guide alignment includes four steps:

- Blade Deflection,
- Blade Guide Vertical Tilt,
- Blade Guide Flange Spacing,
- Blade Guide Horizontal Tilt.

Perform the blade guide alignment after you have aligned the blade on the wheels. After blade guide alignment, check the scale indicator to make sure it is adjusted properly ([See Section 4.13](#)).

NOTE: During blade guide alignment, remove the blade guide adjusting screws and apply a lubricating oil such as 10W30 or Dexron III to each screw. This will prevent the screws and threaded holes from corroding and make screw adjustments easier.

6.2.5 Blade Deflection

Perform the following steps to achieve proper blade deflection with the blade guides.

1. Set the blade guide arms fully close.
2. If the blade wheels adjustment has been performed correctly, measure the actual distance with a tape from the rope to the bottom of the blade.
3. Install the blade guides. Make sure the two set screws shown are threaded into the blade guide shaft until they touch each other.

See Figure 6-25.

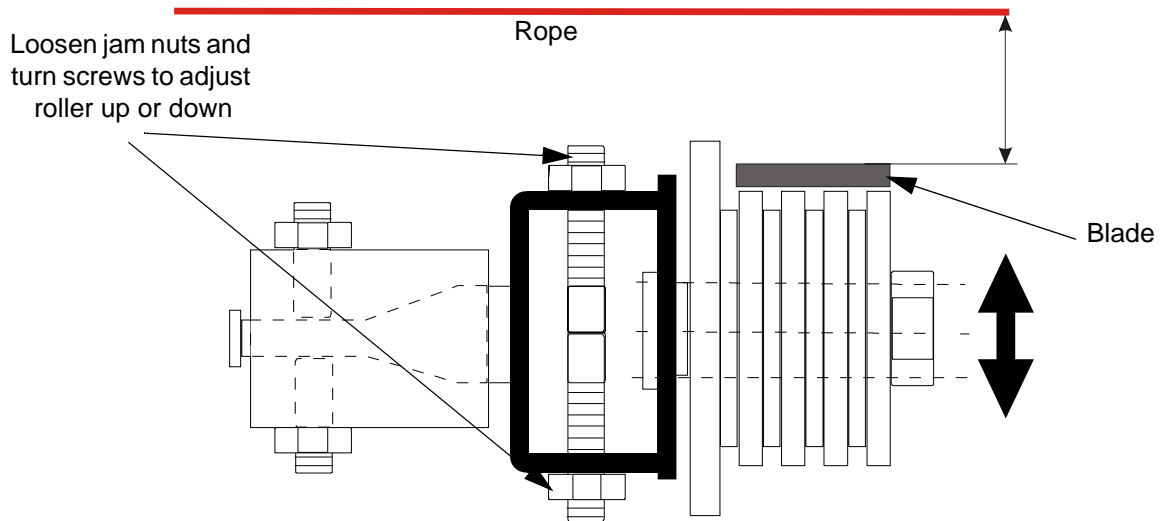

FIG. 6-25

4. Loosen the jam nut and tighten the appropriate screw until the blade guide deflects the blade 6.0 mm.
5. Repeat for the other blade guides.

NOTE: Be sure that the blade guide touches the blade in both guide assemblies.

6.2.6 Blade Guide Horizontal Tilt Adjustment

1. Attach ropes to the upper holes of the alignment bracket. Attach the tools to the blade near the upper blade guides mount as shown. Be sure the tools do not rest on a tooth or burr, and are lying flat against the blades.

See Figure 6-26.

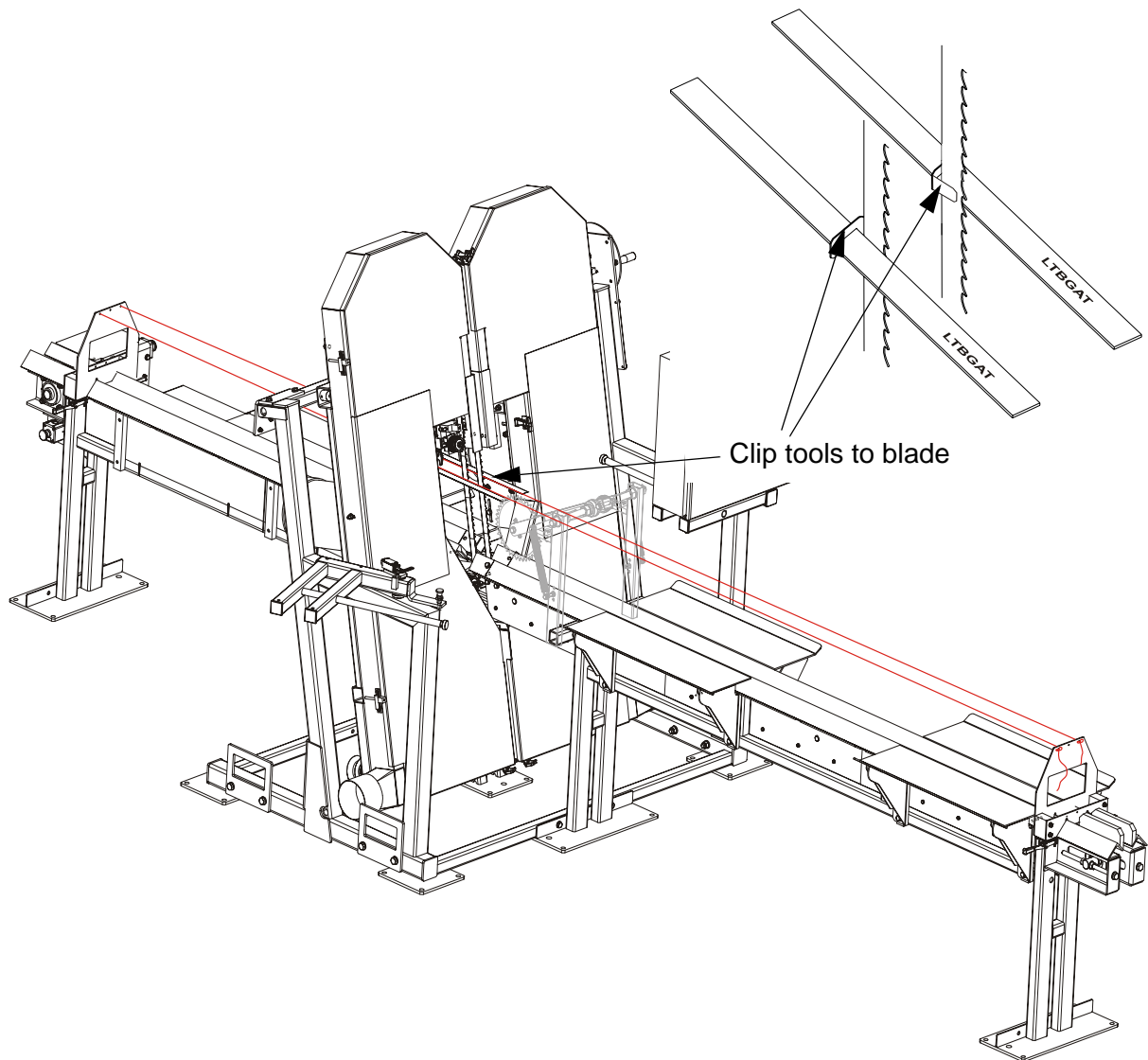

FIG. 6-26

Check that the blade guide does not tilt the blade left or right. A Blade Guide Alignment Tool (LTBGAT) is provided to help you measure the vertical tilt of the blade.

2. Position the tools near the upper blade guide.
3. Measure the distance from the edge of the tool to the ropes at the back end of the tool and then at the front end of the tool.

See Figure 6-27.

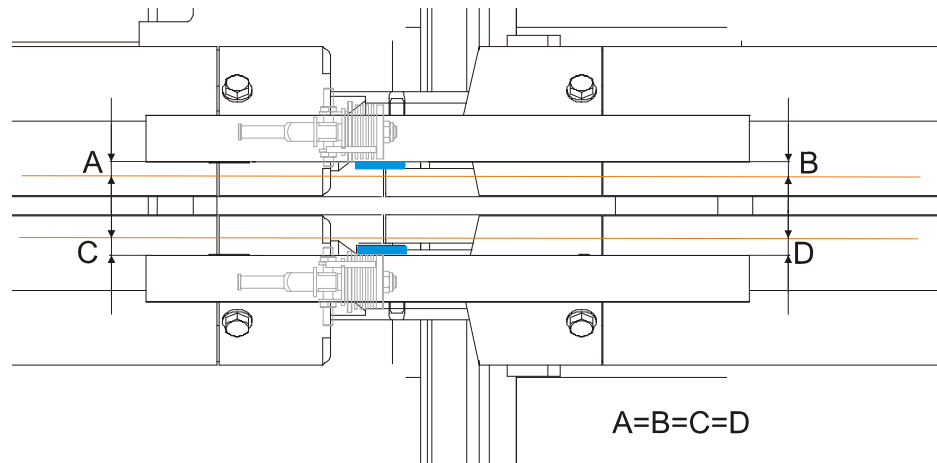

FIG. 6-27

4. The all four distances should be equal. If the distances A and C or B and D differ, it is necessary to check the saw heads centring ([See Step 9.](#) of the blade wheels adjustment procedure). If the distances A and B or C and D differ, adjust the horizontal tilt of the blade guide using the adjustment screws shown in the figure below.

See Figure 6-28. Loosen the jam nuts on the left and right horizontal tilt adjustment screws. To tilt the roller left, loosen the right screw and tighten the left screw. To tilt the roller right, loosen the left screw and tighten the right screw. Tighten the jam nuts and recheck the tilt of the blade.

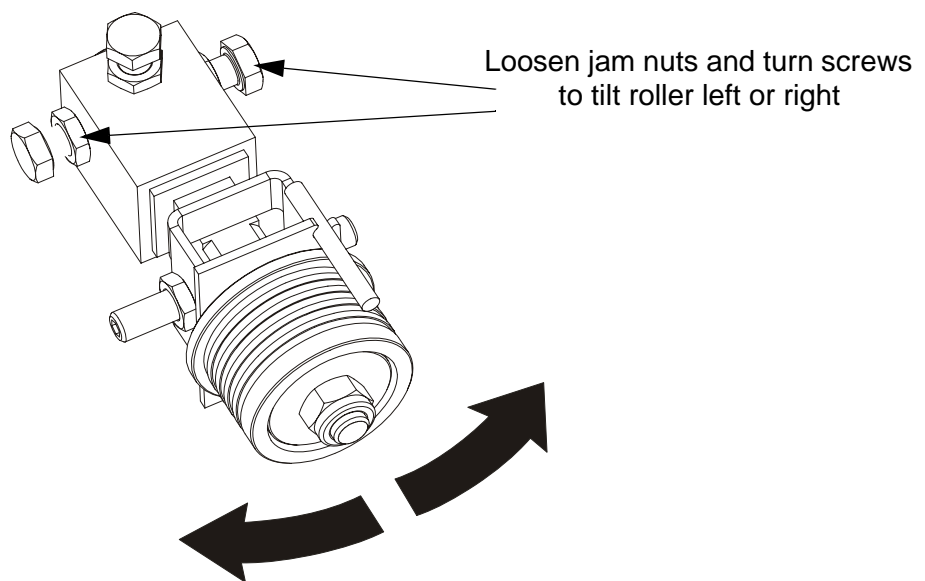

FIG. 6-28

5. Attach ropes to the lower holes of the alignment bracket. Attach the tools to the blade near the lower

blade guide mount blocks and repeat above steps. Adjust the horizontal tilt of this guide if necessary.

NOTE: If major adjustments to blade guide tilt were made, measure the actual distance with a tape from the rope to the bottom of the blade again to ensure the correct 6.0 mm (0.24") blade guide deflection. Adjust if necessary.

6.2.7 Blade Guide Spacing

HINT: When adjusting blade guide spacing, loosen the top set screw and one side set screw only. This will ensure horizontal and vertical tilt adjustments are maintained when the set screws are retightened.

1. Adjust the lower blade guide so the blade guide flange is approximately 1.5 – 3.0 mm (0.06 - 0.12") from the back of the blade.
2. Loosen one side and one top set screw shown. Tap the blade guide forward or backward until properly positioned.

See Figure 6-29.

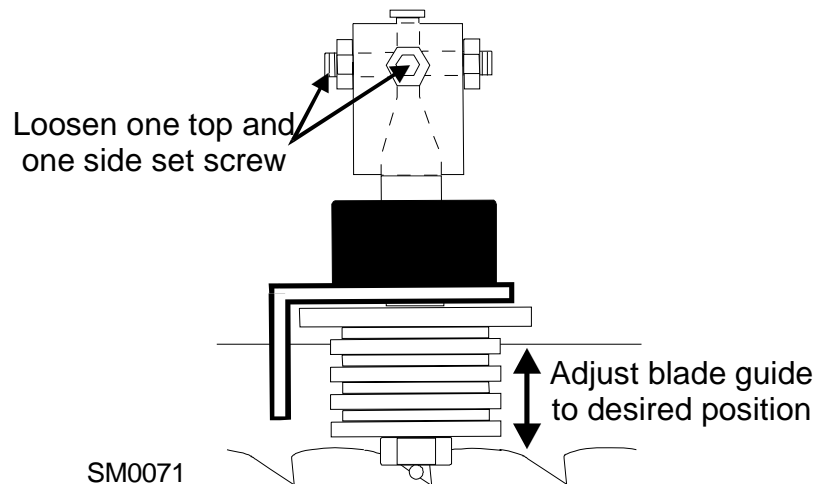

FIG. 6-29

3. Retighten the two set screws.
4. Adjust upper blade guide in the same way so the blade guide flange is approximately 1.5 – 3.0 mm (0.06 - 0.12") from the back of the blade.

6.2.8 Blade Guide Vertically Tilt Adjustment

1. Finally, both blade guides must be tilted vertically. Adjust the blade guide arm halfway in.

See Figure 6-30.

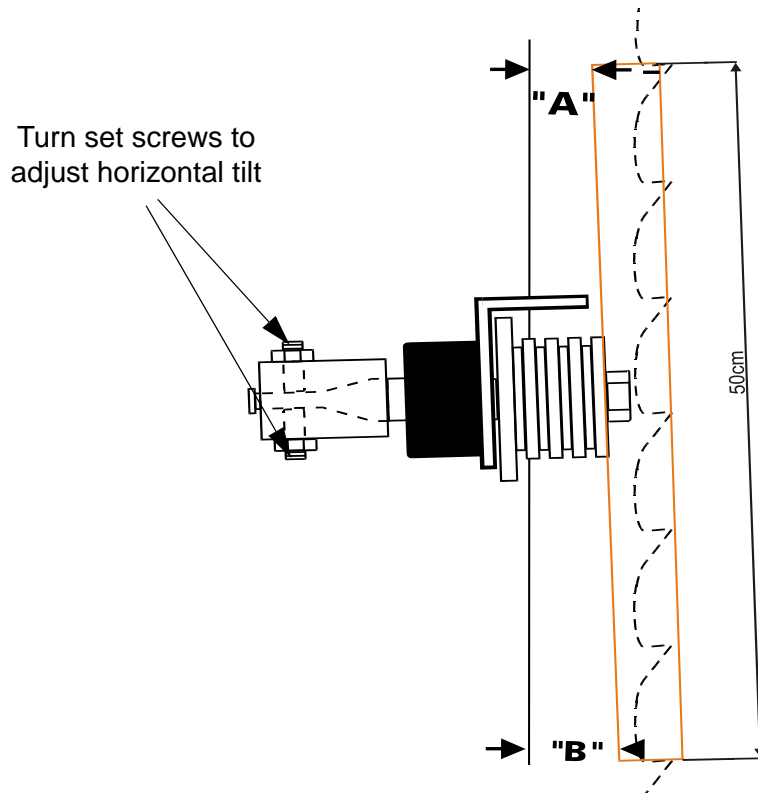

FIG. 6-30

2. Place the Blade Guide Alignment Tool against the face of the upper blade guide roller.
3. Center the tool on the roller and measure the distance between the back edge of the blade and the ruler at the end closest to the lower blade guide ("B").
4. Measure between the back edge of the blade and the other end of the ruler ("A").
5. The roller should be tilted slightly up ($A = B - 6.0 \text{ mm [0.24"]}$).
6. Use the set screws to adjust the horizontal tilt of the roller.
7. Repeat steps 3-7 for the lower blade guide roller.

NOTE: Once the blade guides have been adjusted, any cutting variances are most likely caused by the blade. See the **Wood-Mizer® Blade Handbook, Form #600**.

6.2.9 Blades Width Scale Adjustment

After the entire resaw has been aligned and all adjustments made, check that the blade height scale indicates the true distance between the blades.

1. Measure the distance between the blades.

See Figure 6-31.

2. View the distance between the blades on the scale with the indicator.

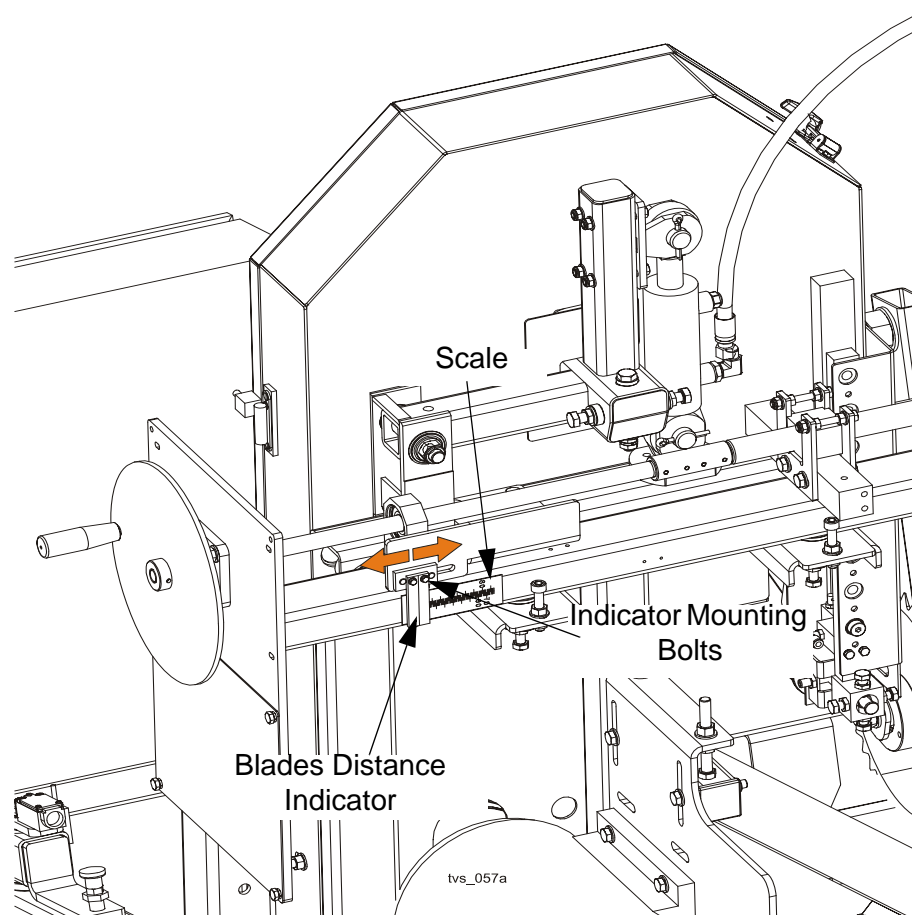



FIG. 6-31

3. Loosen the indicator bracket mounting bolts and adjust the bracket until the indicator is aligned with the correct mark on the scale. Retighten the bracket mounting bolts.

 **CAUTION!** Don't adjust saw head turnbuckle bracket nuts. Turnbuckles are factory set and should have a little gap between brackets.

See Figure 6-32.

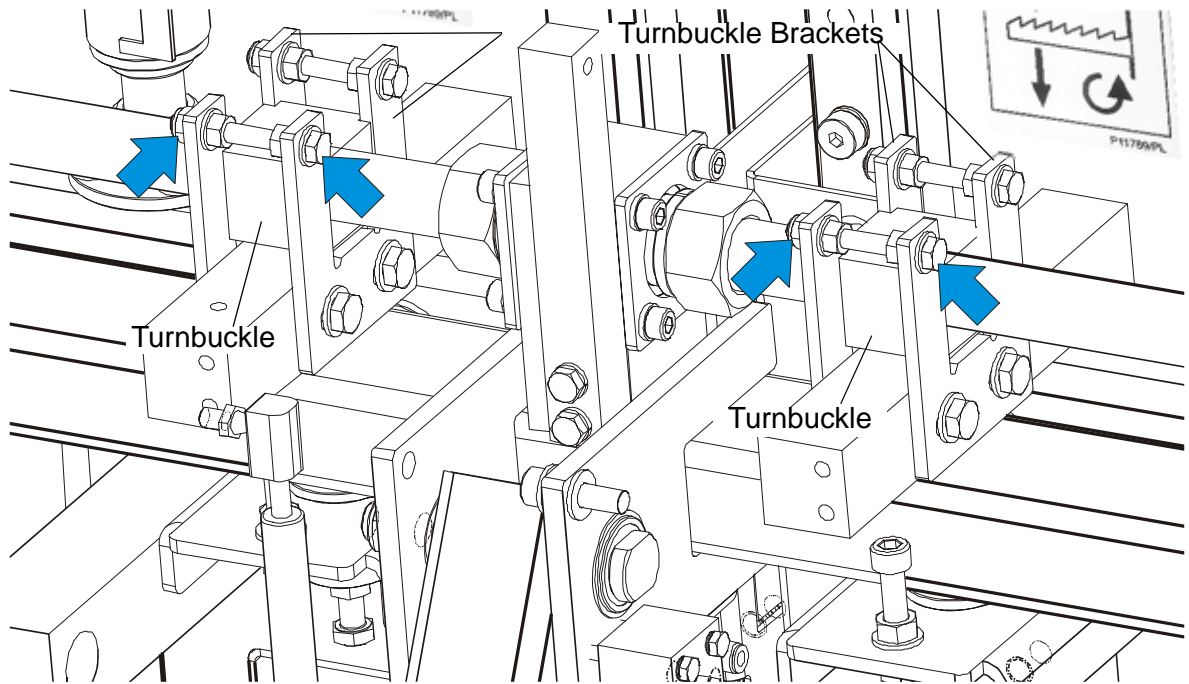

FIG. 6-32

6.2.10 Track Chain Mounting

Mount and tension the feed chain.

1. Loosen the chain tensioner.
2. Route the feed chain as shown on the picture below. Be sure the chain is mounted in correct direction.
3. Connect the chain using the chain link.
4. Tighten the chain. [See Section 5.7.](#)

See Figure 6-33.

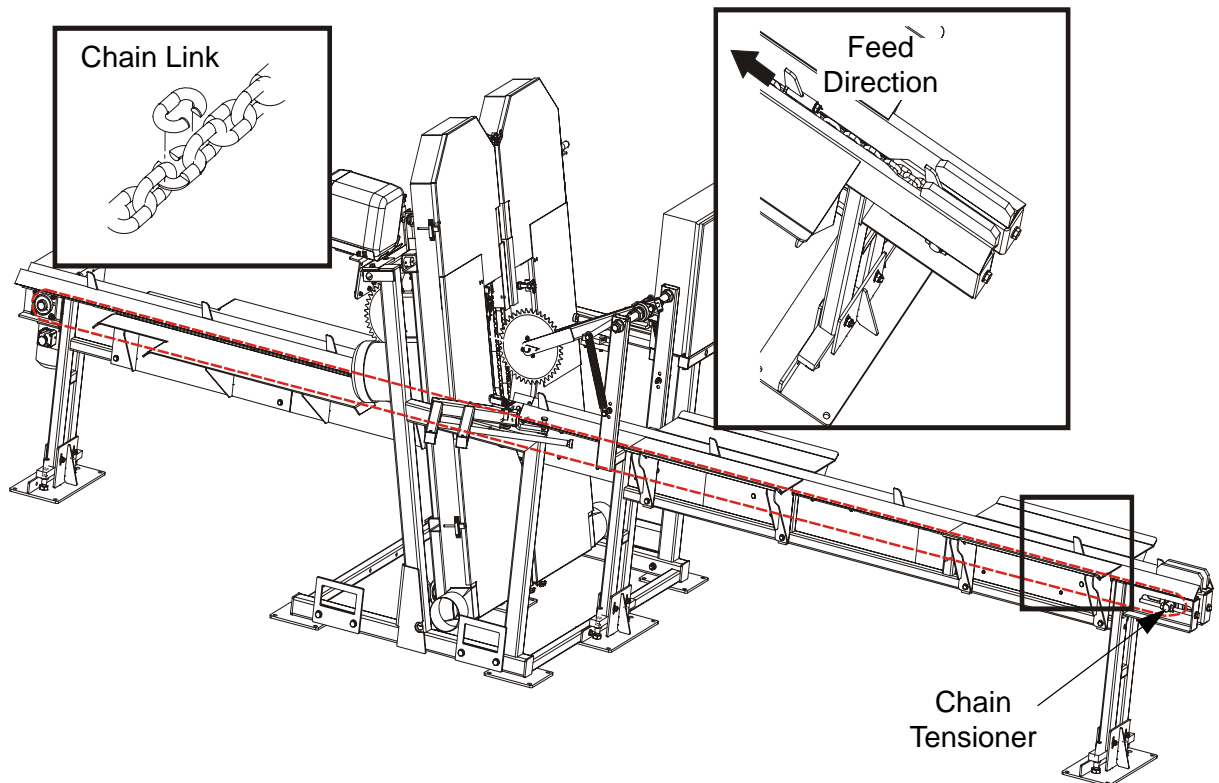

FIG. 6-33

SECTION 7 SPECIFICATIONS

7.1 Overall Dimensions

See Figure 7-1. The major dimensions of the Twin Vertical Saw are shown below (all dimensions are in millimeters).

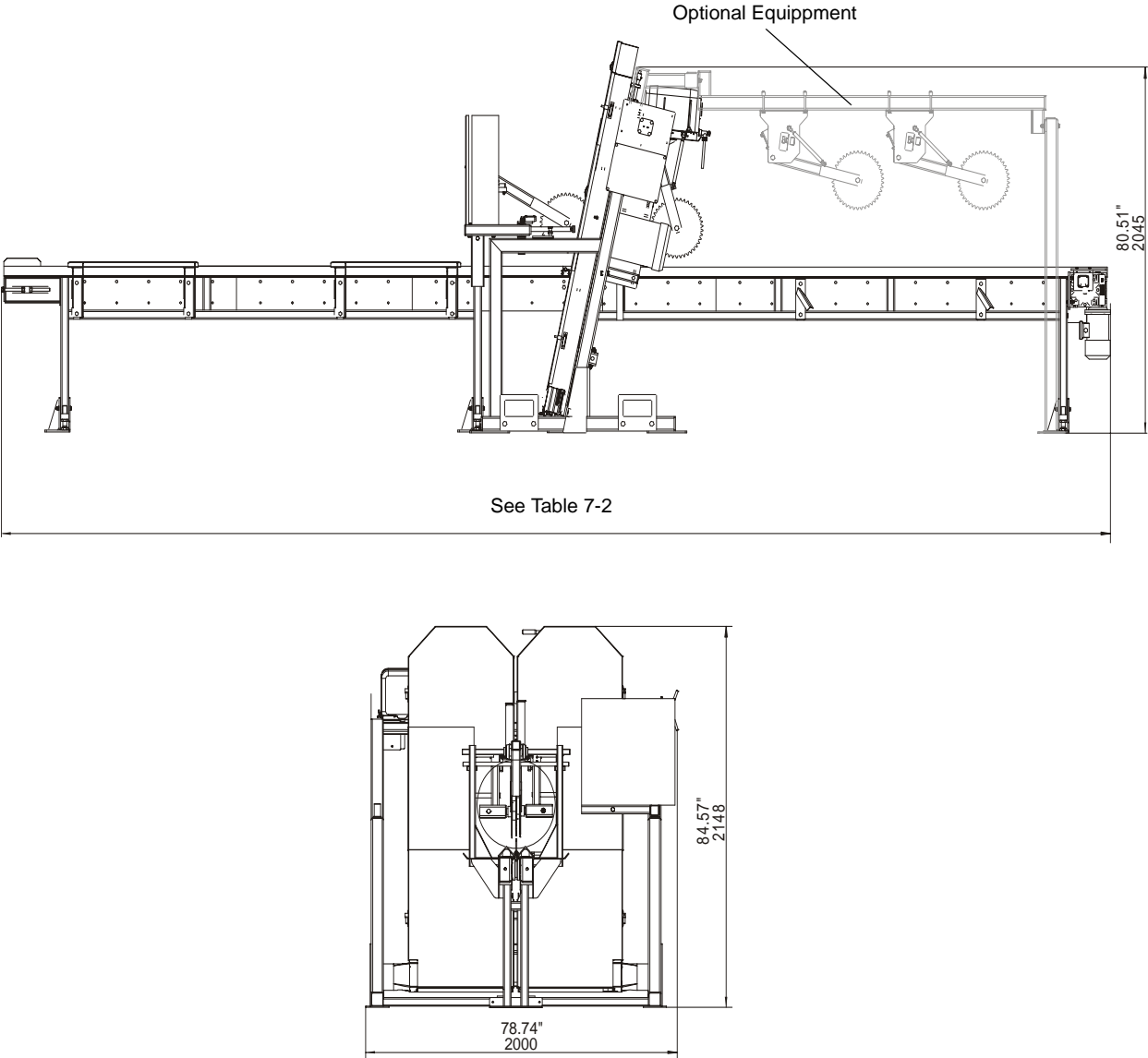

FIG. 7-1

7 SPECIFICATIONS

Overall Dimensions

See Table 7-1. The overall dimensions of the TVS are listed in the tables below.

Weights	Heads - 936kg / 2063 lb
	TVSIV2.4I - 318kg / 701 lb
	TVSIV3.6I - 400kg / 882 lb
	TVSOV4.8 - 486kg / 1071 lb
Height	2148 mm / 84.57"
Width	2000 mm / 78.74"

TABLE 7-1

See Table 7-2. The TVS length depending on table configuration.

Table Configuration	Length [m]
TVSIV2.4 + TVSOV2.4	4.8 / 15.75"
TVSIV2.4 + TVSOV3.6	6.0 / 19.68"
TVSIV2.4 + TVSOV4.8	7.2 / 23.62"
TVSIV3.6 + TVSOV2.4	6.0 / 19.68"
TVSIV3.6 + TVSOV3.6	7.2 / 23.62"
TVSIV3.6 + TVSOV4.8	8.4 / 27.56"

7 SPECIFICATIONS

Cutting Capacity

7.2 Cutting Capacity

See Table 7-3. The material size and performance capacities of the TVS are given below.

Cutting Length	1 - 3 m / 3.28- 9.84 ft
Cutting Width	70-250 mm / 2.75-9.84 "
Feed Speed	(0-25 m / 0-82 ft)/min
Minimum Log Width	100 mm / 3.937"
Maximum Log Width	400 mm / 11.81"

TABLE 7-3

See Table 7-4. Wood-Mizer offers three types of blades to provide efficient sawing. The type of wood you saw should determine which blade you choose for optimum performance.

Motor Size	Recommended Blade Type		
	Softwood	Medium Hardwood	Frozen Timber or Dense Hardwood
5 HP - 15 HP	.042 x 7/8 x 1 1/4"x184"	.042 x 7/8 x 1 1/4 "x184"	.045 x 7/8 x 1 1/4" F1 x184"

7.3 Blade Motor Specifications

See Table 7-5. See the table below for motor specifications for TVS.

Motor Type	Manufacturer	Model	Power	Other Specifications
Blade Motor	Indukta, Poland	SG132S -2B HM	7,5kW	400 V/50Hz; 13,9 Amp; 2920 r.p.m.
	Indukta, Poland	PSg-132 S2 - HM	11kW	400 V/50Hz; 20,3 Amp; 2920 r.p.m.
	Siemens, Germany	1LE1002 1DA33-4AA0	15kW	460V/60Hz; 26,5A 3530 r.p.m.
Feed Track Motor	Besel, Poland	SKh80X-4C1 IMB14/1-162	1,1kW	400 V/50Hz; 2,3 Amp; 1380 r.p.m.

TABLE 7-5

See Table 7-6. The noise levels of the Wood-Mizer TVS are listed below¹².

	Noise Level L _{EX8}
TVS	89,5 dB (A)

TABLE 7-6

1. The noise level measurement was taken in accordance with PN-EN ISO 3746 Standard . The noise exposure level given above concerns an 8-hour work day.
2. The measured values refer to emission levels, not necessarily to noise levels in the workplace. Although there is a relation between emission levels and exposure levels, it is not possible to determine with certainty if preventives are needed or are not needed. The factors affecting a current level of noise exposure during work are inter alia room characteristics and characteristics of other noise sources, e.g. number of machines and machining operations nearby. Also, the permissible exposure level value may vary depending on country. This information enables the machine's user to better identify hazards and a risk .

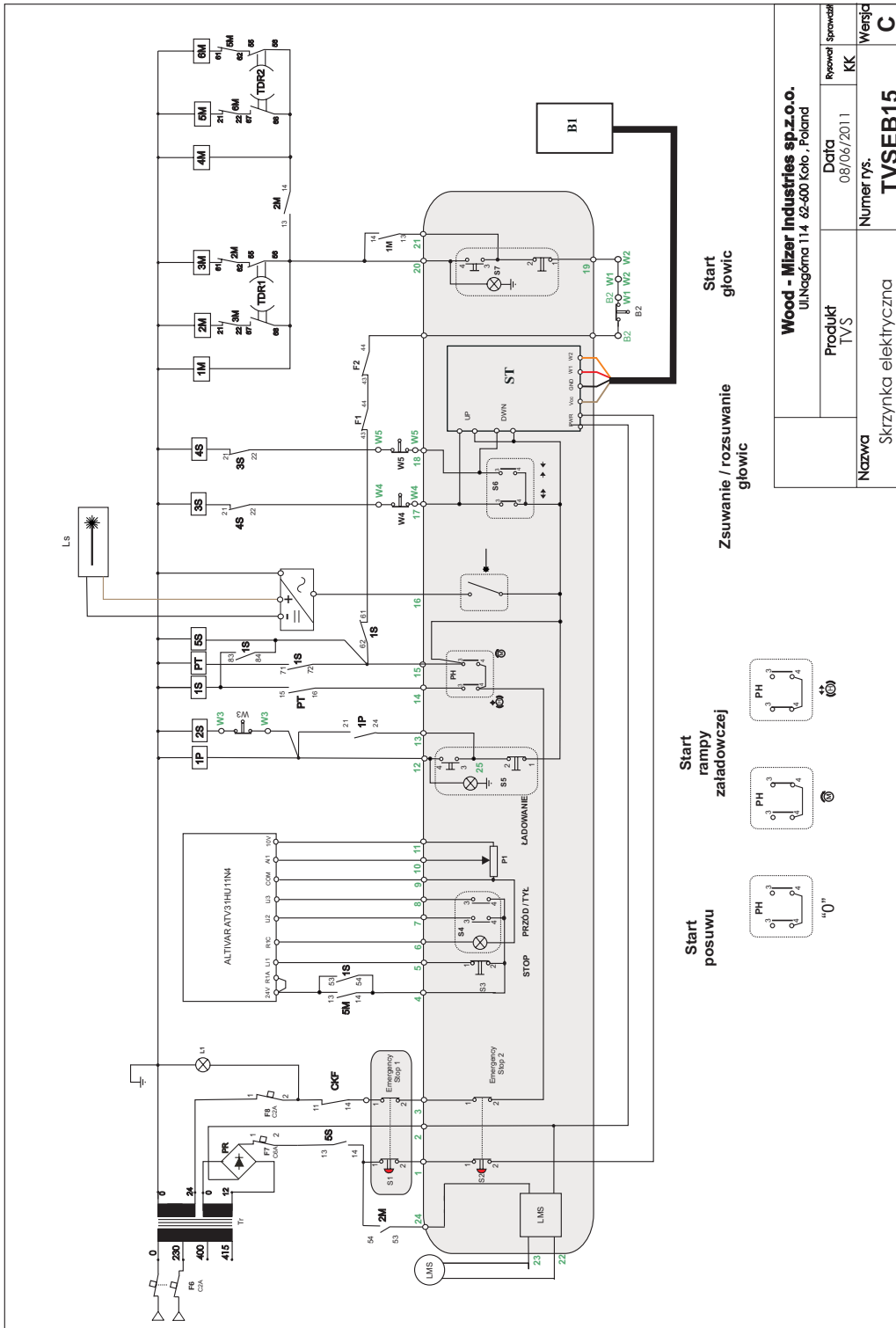
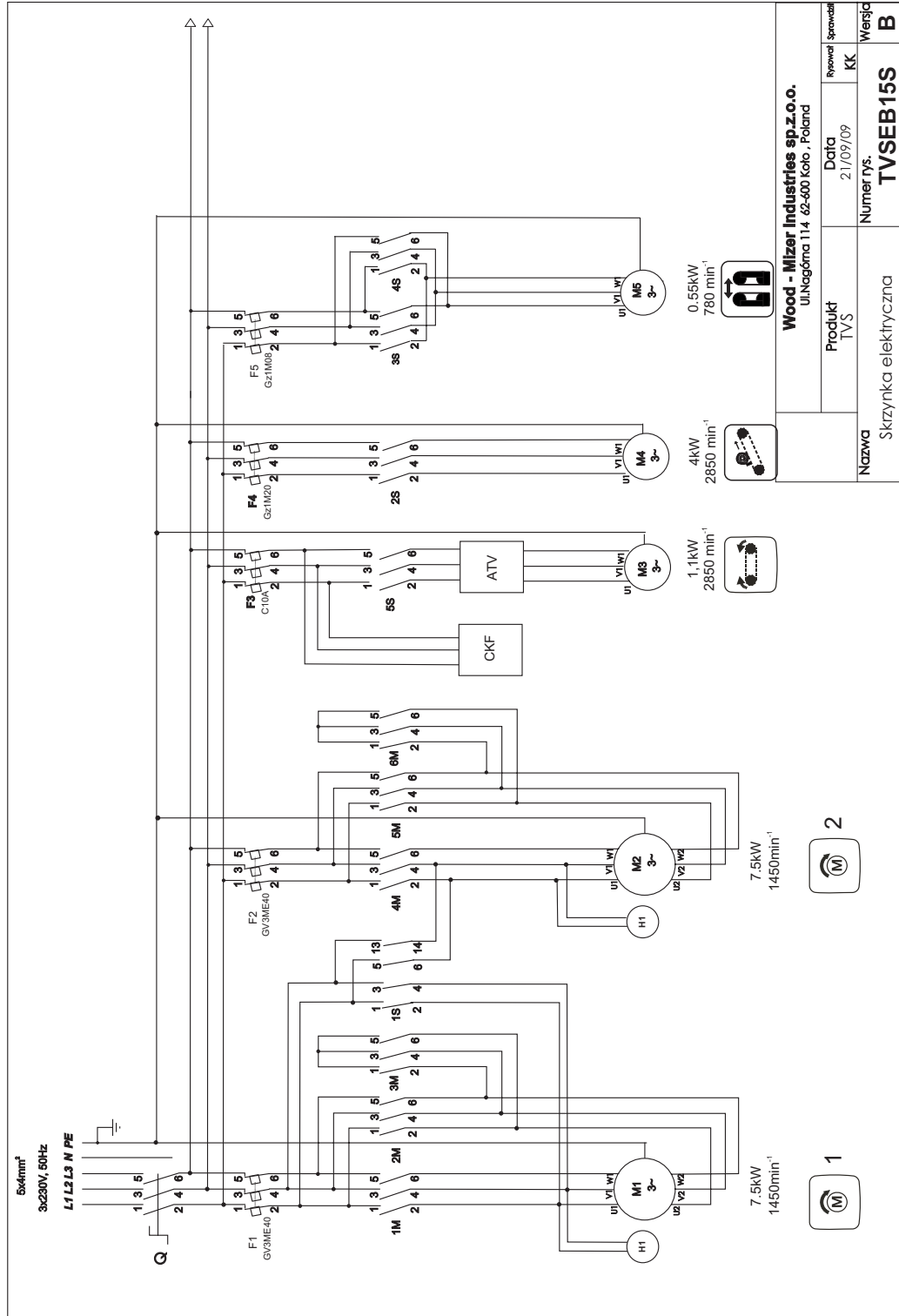

FIG. 7-2

7.5 Electrical Diagram, TVS EB15S



Wood - Mizer Industries sp.z.o.o. ul.Nagórna 114 62-600 Koło, Poland		Revizja	Sprawdził
Produkt	TVS	Data	21/09/09
Nazwa	Skryzynka elektryczna	Numer rys.	TVSEB15S
		Wersja	B

FIG. 7-2

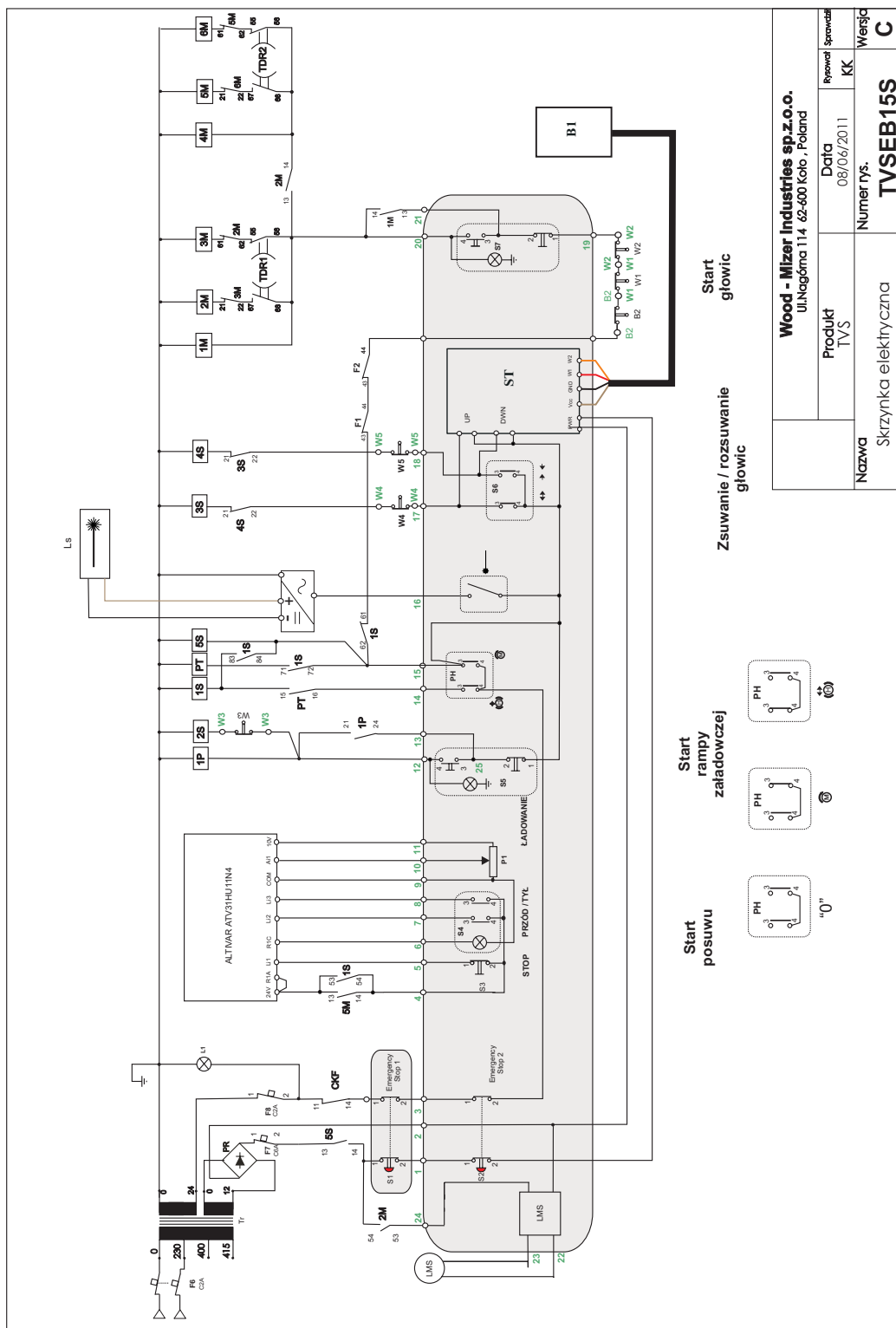

Wood - Mizer Industries sp.z.o.o. Ul.Nagólna 114 62-600 Koło, Poland		Rysował / Sprawdził
Produkt	TVS	KK
Data	08/06/2011	
Nazwa	Skrzynka elektryczna	Numer rys.
		TVSEB15S
		Wersja
		C

FIG. 7-2

7.6 Electrical Component List, TVS EB15S

Symbol	Description	Wood-Mizer Part No.	Manufacturer
Q	Switch ABB OT100 E3	501017	ABB
F1, F2	Motor Circuit Breaker GV3P40	090436	SCHNEIDER ELECTRIC
1M, 2M, 4M, 5M	Contactora LC1 D25 B7	090923	SCHNEIDER ELECTRIC
3M, 6M	Contactora LC1 D18B7	084306	SCHNEIDER ELECTRIC
1S, 2S	Contactora LC1 D0610B7	084308	SCHNEIDER ELECTRIC
3S, 4S, 5S	Contactora LC1 D0601B7	084309	SCHNEIDER ELECTRIC
F3	Circuit Breaker C60N 3P C10	084317	SCHNEIDER ELECTRIC
F4	Circuit Breaker Gz1 M14	090561	SCHNEIDER ELECTRIC
F5	Circuit Breaker Gz1 M08	083659	SCHNEIDER ELECTRIC
F6	Circuit Breaker C60N 2P C2 24332		SCHNEIDER ELECTRIC
F7	Circuit Breaker C60N 1P C6 24399	095842	SCHNEIDER ELECTRIC
F8	Circuit Breaker C60N 1P C2 24396	088278	SCHNEIDER ELECTRIC
TR	Transformer TSM160		INDEL
TDR1, TDR2	Relay, Time Delay LAD S2	084037	SCHNEIDER ELECTRIC
L1	Control Light M22 White-LED24V	090448	MOELLER
ATV	Speed Controller ATV31HU11M3	093489	SCHNEIDER ELECTRIC
CKF	Phase Failure Relay 72.31.8.400.0000	501016	FINDER
M1, M2	Motor SG132S -2PC HM	089049	INDUKTA
S1	Switch, XB4 BS542 Emergency	086556	SCHNEIDER ELECTRIC
S2	Switch M22 WRLK3-G	091359	MOELLER
S3	Button M22 WRLK3-G	091467	MOELLER
S4,	Switch M22-DDL-S-X7/X7		MOELLER
S5, S6	START-STOP Switch M22 DDL-GR-X1/X0/K11/230-W	090452	MOELLER
PH	Key Switch M22-WRS3	091361	MOELLER
PT	Time Relay D6DA	094989	Tele Haase

7.7 Electrical Diagram, TVS EC15

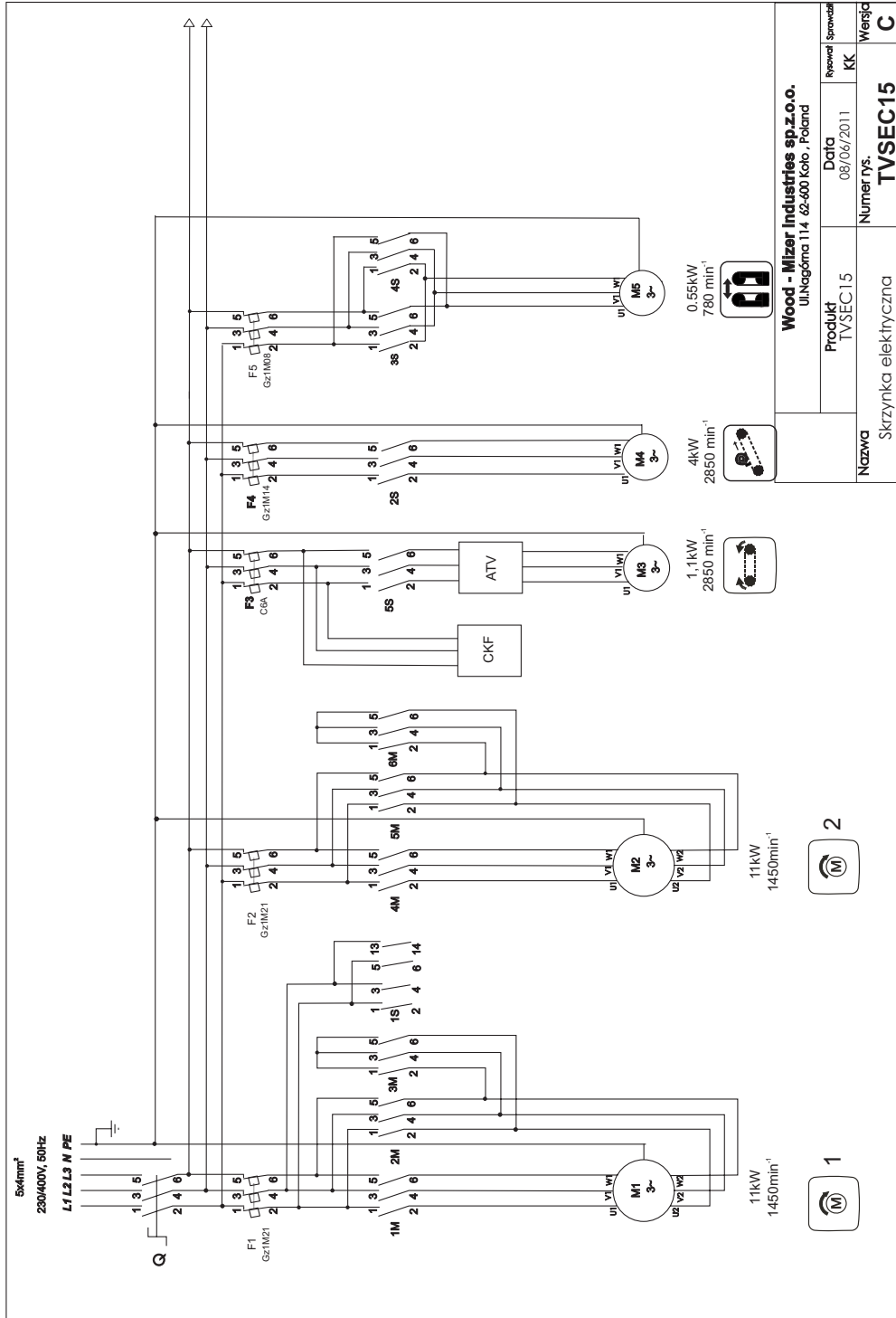

FIG. 7-2

7 SPECIFICATIONS

Electrical Diagram, TVS EC15

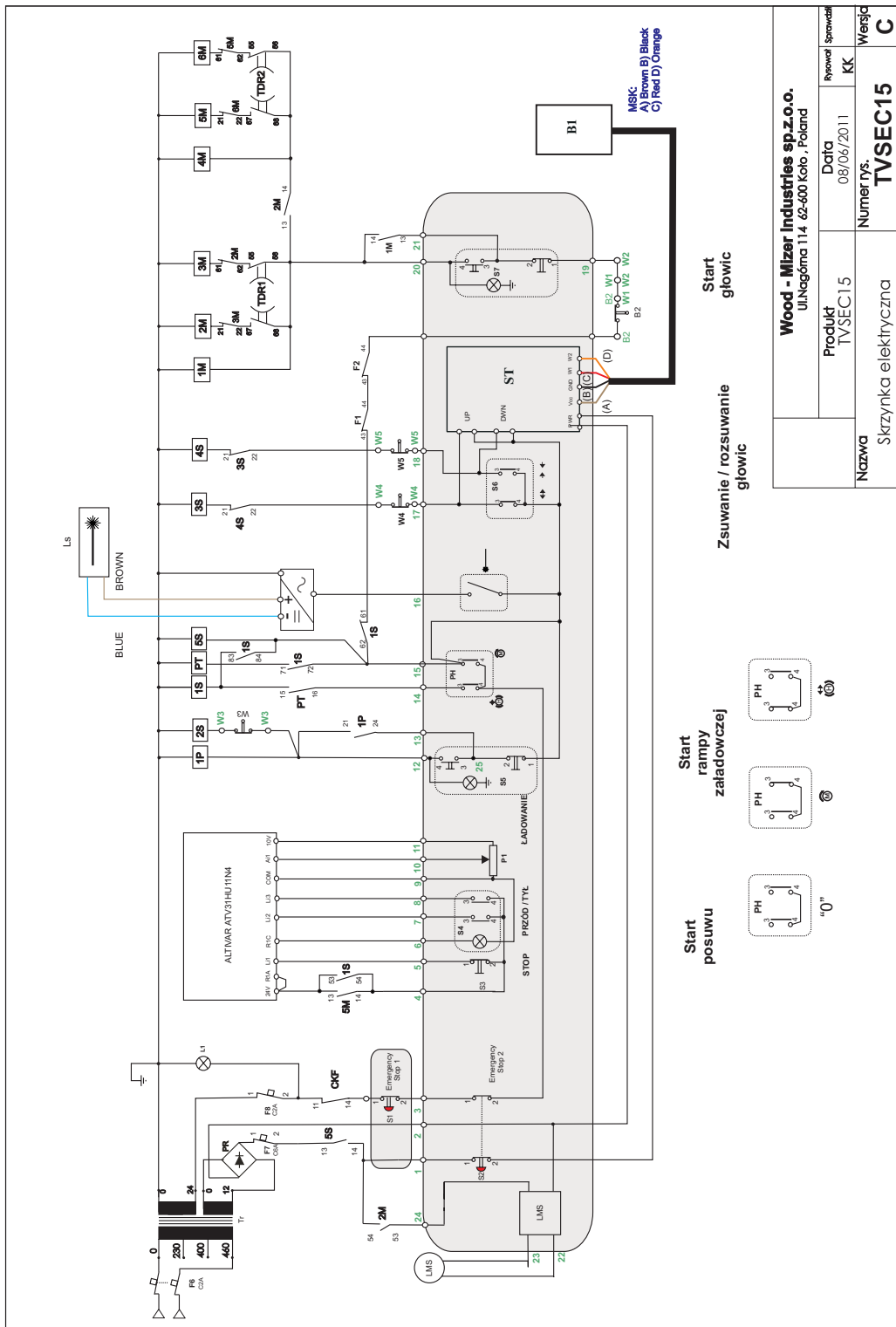

FIG. 7-2

7.8 Electrical Component List, TVS EC15S

Symbol	Description	Wood-Mizer Part No.	Manufacturer
Q	Switch ABB OT40 F3	502312	ABB
F1, F2	Motor Circuit Breaker Gz1 M21	084330	SCHNEIDER ELECTRIC
1M, 2M, 4M, 5M	Contactor LC1 D18B7	084306	SCHNEIDER ELECTRIC
3M, 6M	Contactor LC1 D09B7	084305	SCHNEIDER ELECTRIC
1S, 2S	Contactor LC1 D0610B7	084308	SCHNEIDER ELECTRIC
3S, 4S	Contactor LC1 D0601B7	084309	SCHNEIDER ELECTRIC
F3	Circuit Breaker C60N 3P C6	091554	SCHNEIDER ELECTRIC
F4	Circuit Breaker Gz1 M14	093905	SCHNEIDER ELECTRIC
F5	Circuit Breaker Gz1 M08	083659	SCHNEIDER ELECTRIC
F6	Circuit Breaker C60N 2P C2 24332		SCHNEIDER ELECTRIC
F7	Circuit Breaker C60N 1P C6 24399	095842	SCHNEIDER ELECTRIC
F8	Circuit Breaker C60N 1P C2 24396	088278	SCHNEIDER ELECTRIC
TR	Transformer TSM160		INDEL
TDR1, TDR2	Relay, Time Delay LAD S2	084037	SCHNEIDER ELECTRIC
L1	Control Light M22 White-LED24V	090448	MOELLER
ATV	Speed Controller ATV31HU11N4	093488	SCHNEIDER ELECTRIC
CKF	Phase Failure Relay 72.31.8.400.0000	501016	FINDER
S1	Switch, XB4 BS542 Emergency	086556	SCHNEIDER ELECTRIC
S2	Switch M22 WRLK3-G	091359	MOELLER
S3	Button M22 WRLK3-G	091467	MOELLER
S4,	Switch M22-DDL-S-X7/X7		MOELLER
S5, S6	START-STOP Switch M22 DDL-GR-X1/X0/K11/230-W	090452	MOELLER
PH	Key Switch M22-WRS3	091361	MOELLER
PT	Time Relay D6DA	094989	Tele Haase

7.9 Electrical Diagram, TVS EH11

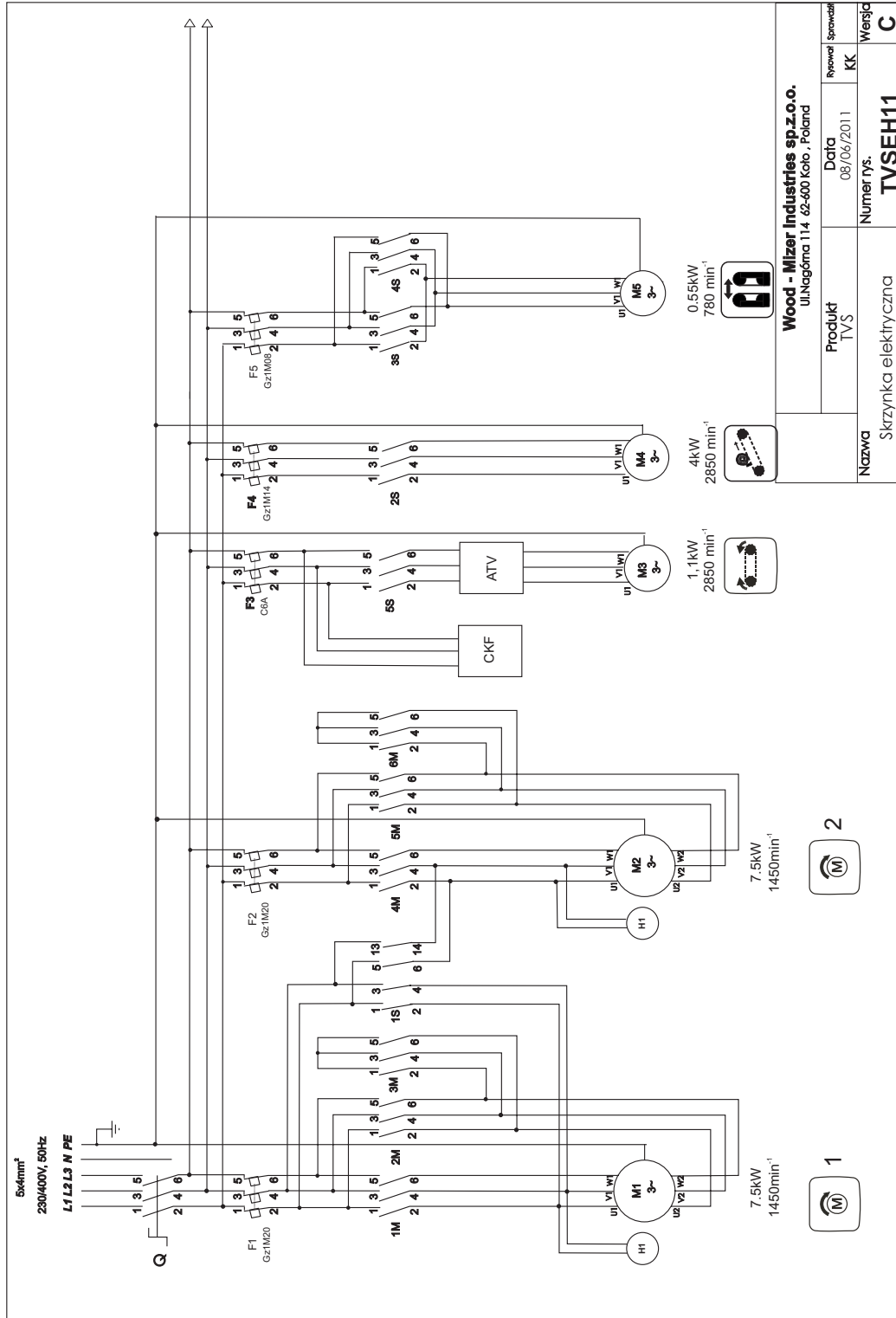

FIG. 7-2

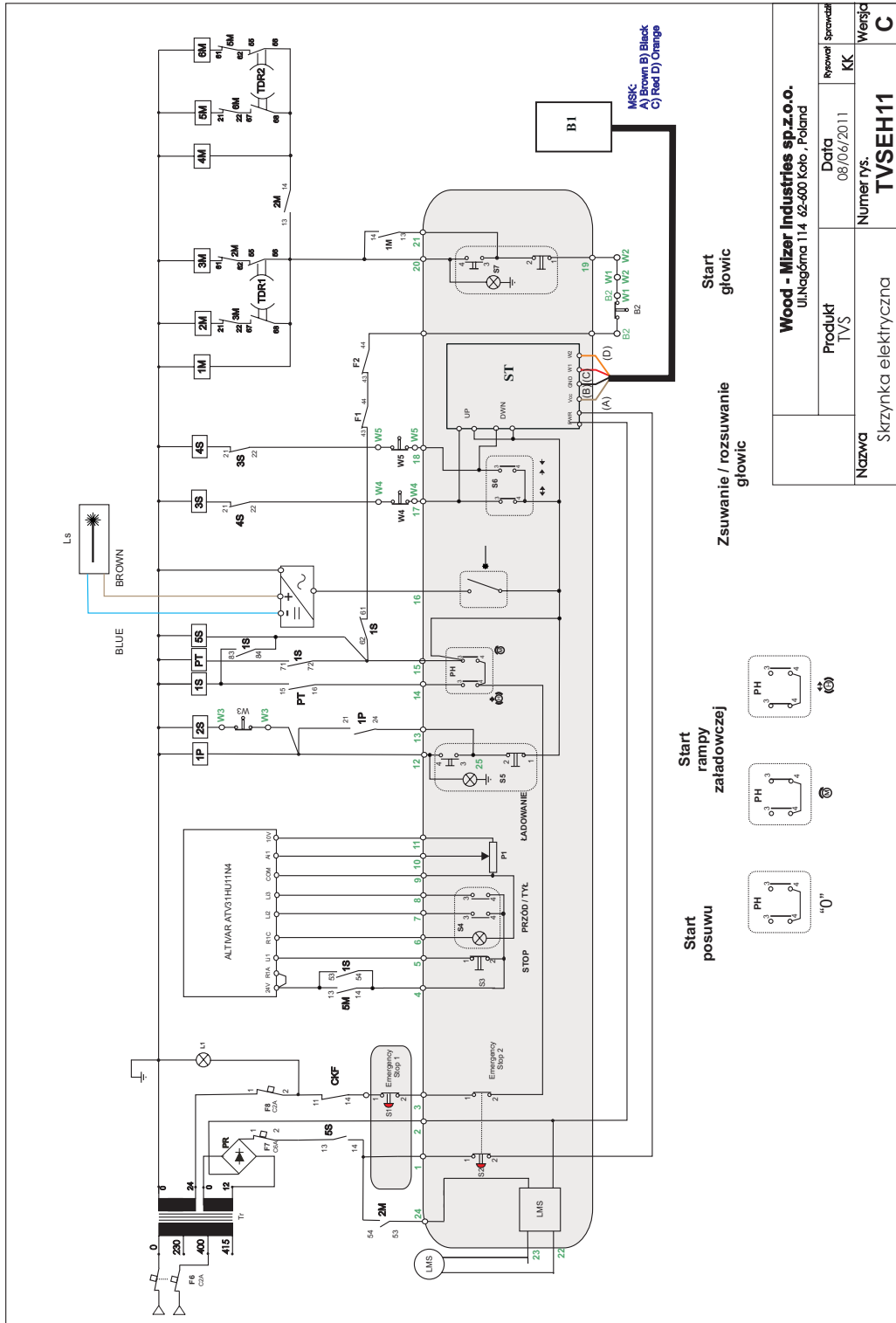

FIG. 7-2

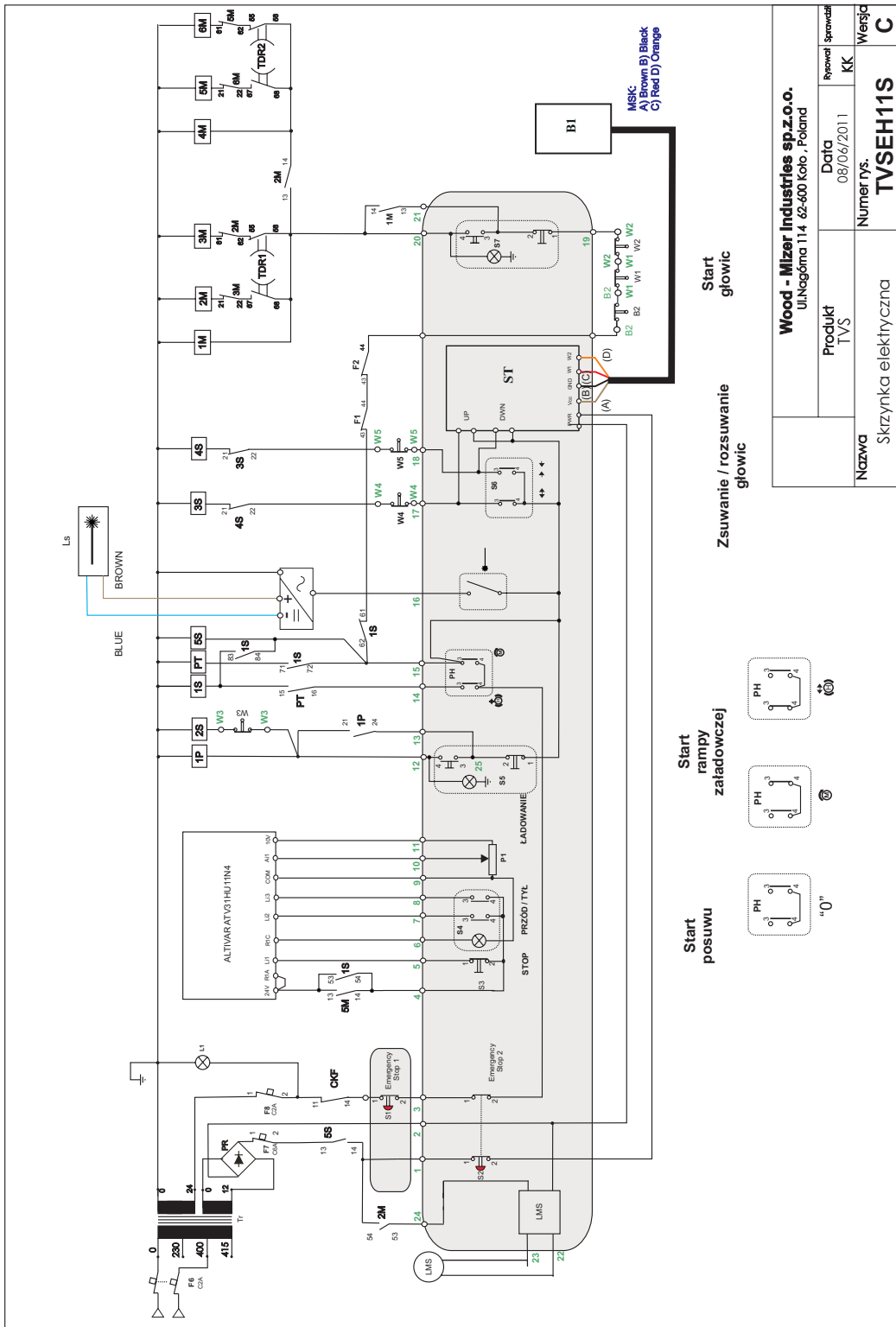
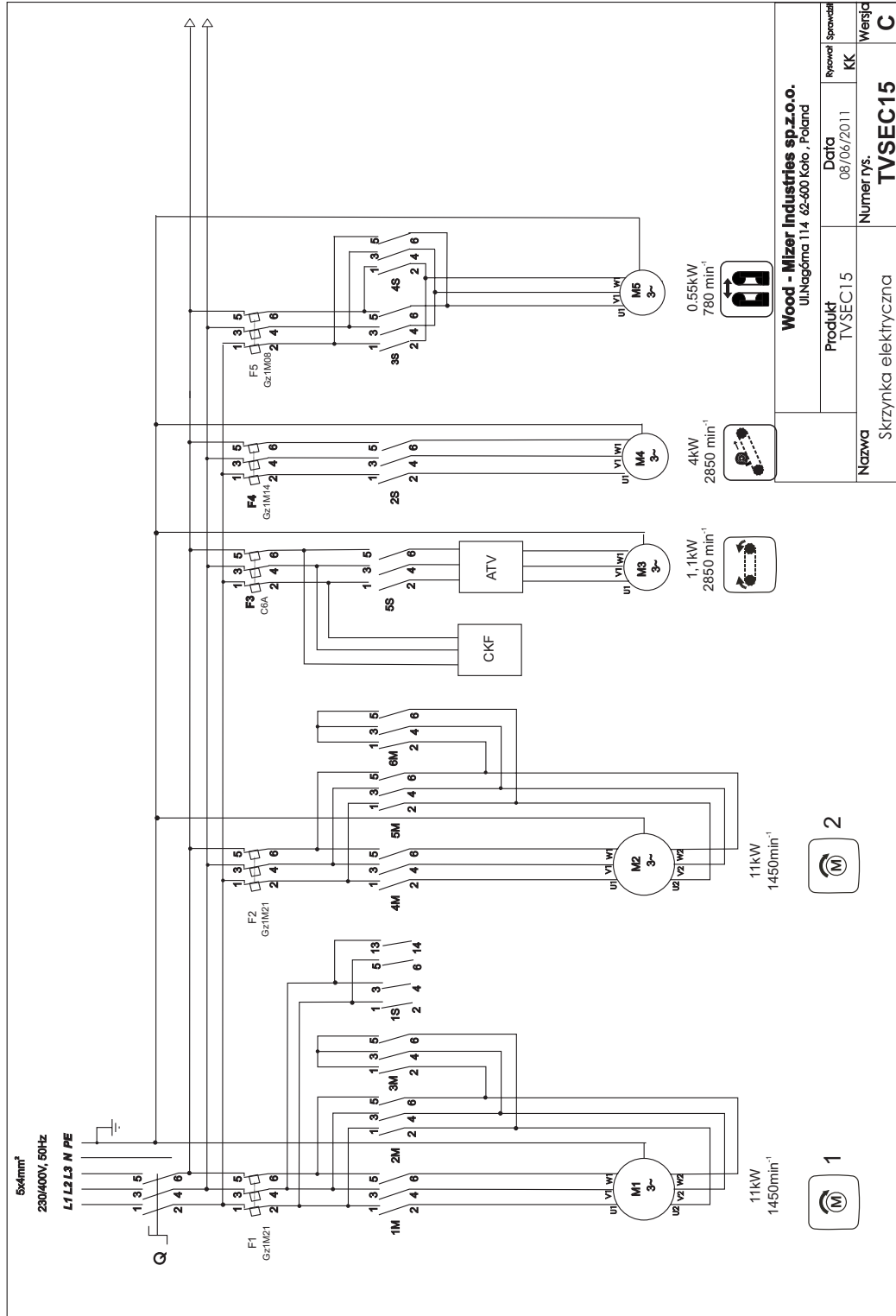

FIG. 7-2

7.11 Electrical Diagram, TVS EH15



Wood - Mizer Industries sp.z.o.o. Ul.Nagõna 114 62-600 Kolo , Poland	
Produkt	TVSEC15
Data	08/06/2011
Revised	KK
Numer Ivs.	TVSEC15
Nazwa	Skrzynka elektryczna
Wersja	C

FIG. 7-2

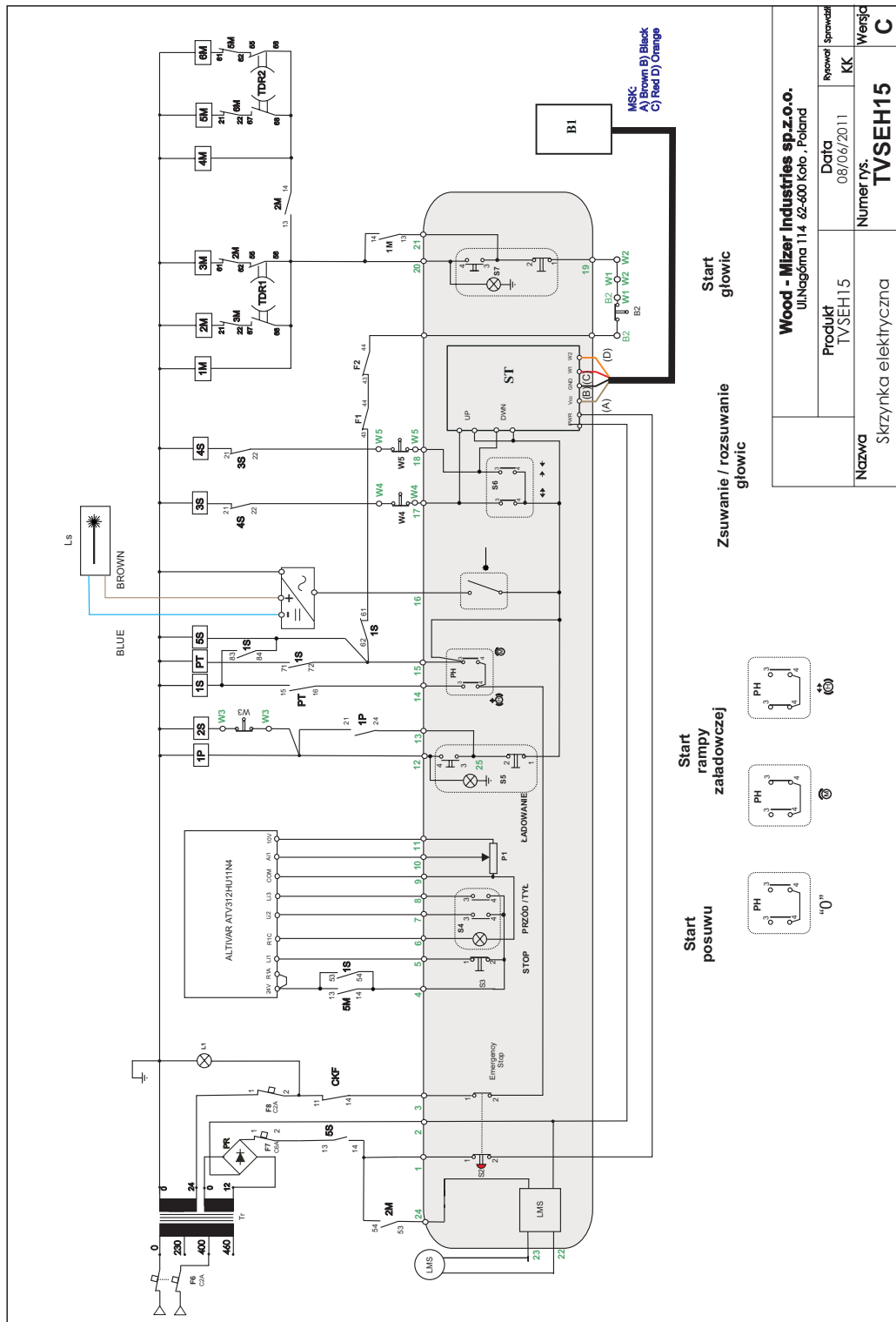

FIG. 7-2

7.12 Electrical Diagram, TVS EH15S

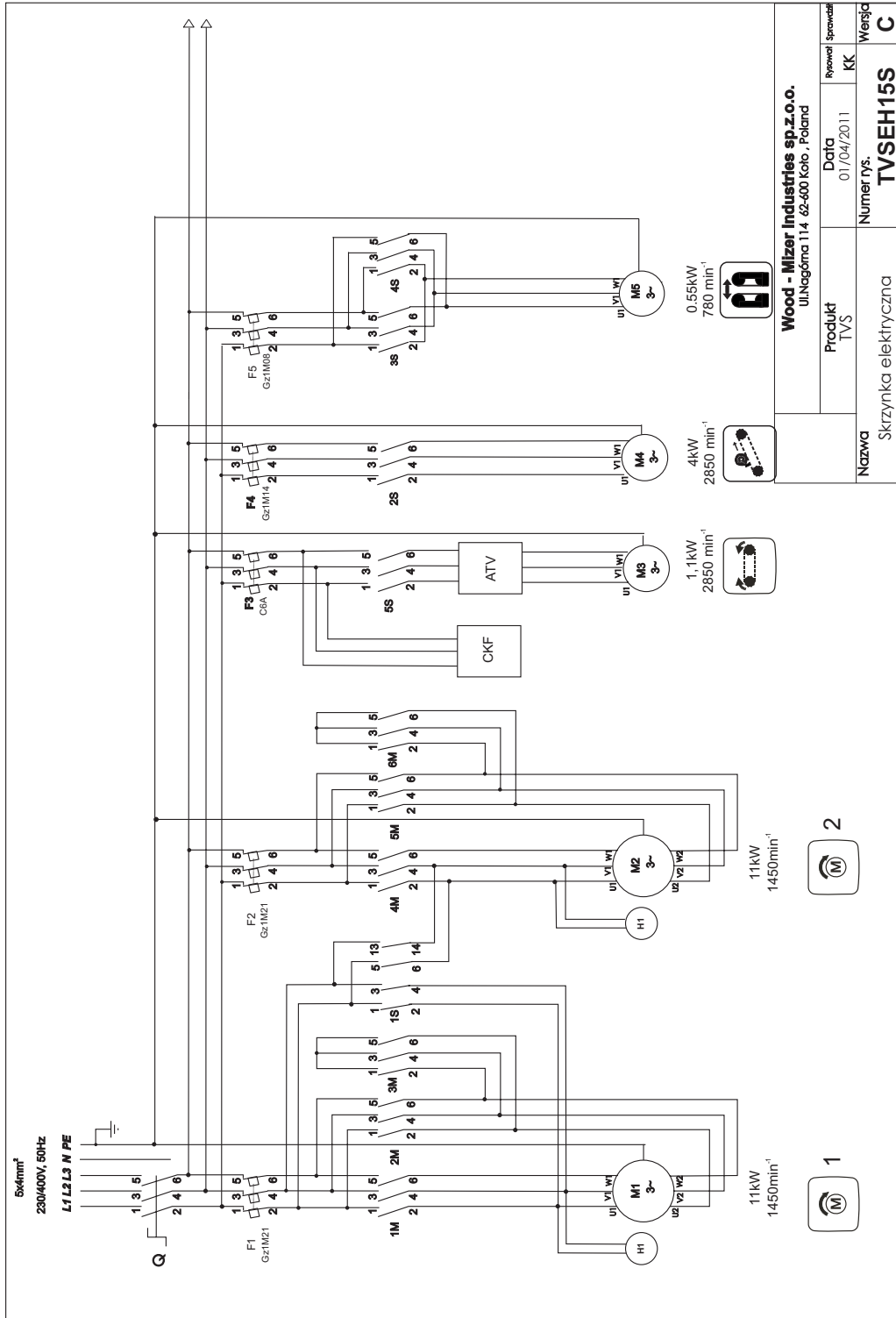

FIG. 7-2

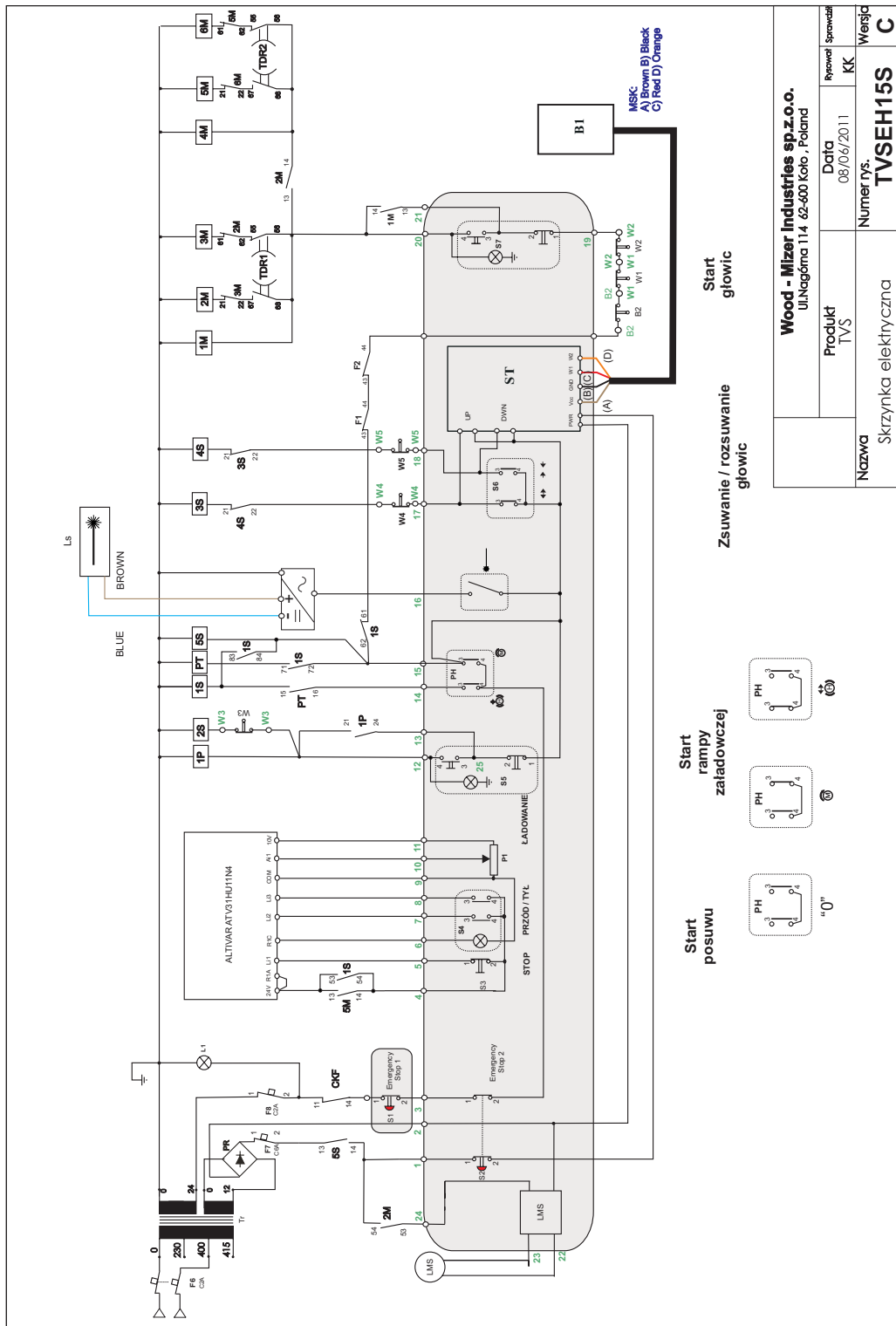

FIG. 7-2

7.13 Electrical Component List, TVS EH15S

Symbol	Description	Wood-Mizer Part No.	Manufacturer
Q	Switch ABB OT100 E3	502312	ABB
F1, F2	Motor Circuit Breaker Gz1 M21	084330	SCHNEIDER ELECTRIC
1M, 2M, 4M, 5M	Contactor LC1 D18 B7	084306	SCHNEIDER ELECTRIC
3M, 6M	Contactor LC1 D09B7	084305	SCHNEIDER ELECTRIC
1S, 2S	Contactor LC1 D0610B7	084308	SCHNEIDER ELECTRIC
3S, 4S	Contactor LC1 D0601B7	084309	SCHNEIDER ELECTRIC
F3	Circuit Breaker C60N 3P C6	091554	SCHNEIDER ELECTRIC
F4	Circuit Breaker Gz1 M14	093905	SCHNEIDER ELECTRIC
F5	Circuit Breaker Gz1 M08	083659	SCHNEIDER ELECTRIC
F6	Circuit Breaker C60N 2P C2 24332		SCHNEIDER ELECTRIC
F7	Circuit Breaker C60N 1P C6 24399	095842	SCHNEIDER ELECTRIC
F8	Circuit Breaker C60N 1P C2 24396	088278	SCHNEIDER ELECTRIC
TR	Transformer TSM160		INDEL
TDR1, TDR2	Relay, Time Delay LAD S2	084037	SCHNEIDER ELECTRIC
L1	Control Light M22 White-LED24V	090448	MOELLER
ATV	Speed Controller ATV31HU11N4	093488	SCHNEIDER ELECTRIC
CKF	Phase Failure Relay 72.31.8.400.0000	501016	FINDER
M1, M2	Motor SG132S -2PC HM	089049	INDUKTA
S1	Switch, XB4 BS542 Emergency	086556	SCHNEIDER ELECTRIC
S2	Switch M22 WRLK3-G	091359	MOELLER
S3	Button M22 WRLK3-G	091467	MOELLER
S4,	Switch M22-DDL-S-X7/X7		MOELLER
S5, S6	START-STOP Switch M22 DDL-GR-X1/X0/K11/230-W	090452	MOELLER
PH	Key Switch M22-WRS3	091361	MOELLER
PT	Time Relay D6DA	094989	Tele Haase

7.14 Dust Extractor Specifications

See Table 7-7. Specifications of the dust extractors used on the TVS are listed below.

Airflow	2400 m ³ /h 7874 ft ³ /h
Inlet diameter	150 mm / 5,9"
Motor power	2x1,5 kW
Number of sacks	2 pcs
Sack capacity	0.25 m ³ 0,82 ft ³
Weight	110 kg / 242,5 lb
Recommended conveying air velocity in the duct	20 m/s 65,6 ft/s

TABLE 7-7



IMPORTANT! The dust extractor hoses must be grounded or made with materials not accumulating electrostatic charge.

SECTION 8 DC ELECTROMAGNETIC BRAKE

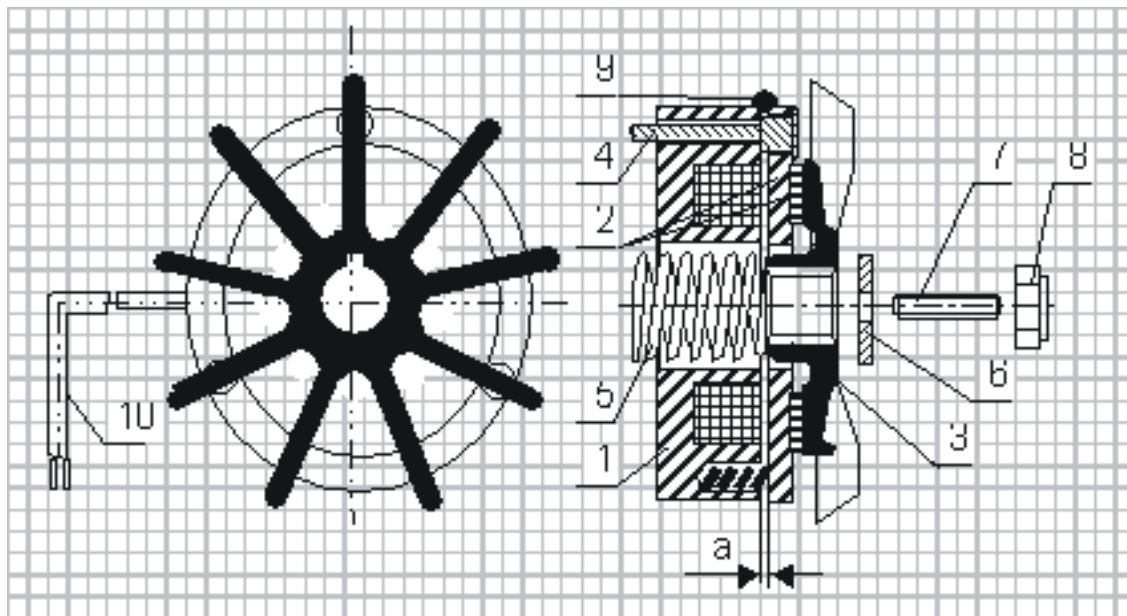

- 1 - Electromagnet,
- 2 - Armature complete with brake linings,
- 3 - Fan,
- 4 - Retaining bolt
- 5 - Central spring,
- 6 - Special washer,
- 7 - Set screw,
- 8 - Self-locking nut,
- 9 - Sealing ring,
- 10 - Output cable.

8.1 Design and principle of operation

The DC electromagnetic brake type H consists of 3 main subassemblies:

- electromagnet (1),
- armature complete (2)
- cast iron fan (3).

Electromagnet (1) energised: The DC voltage from the motor applied via the rectifying circuit causes the attraction of the armature (2) releasing the brake and thus the fan (3) is free to rotate.

Electromagnet (1) de-energised: The electromagnet stops to attract the armature (2) and spring presses the armature with brake linings (2) against the fan and the brake is thus applied.

8.2 Service

During normal operation and at the routine inspections verify the air gap and check if all screws are tight. In case when any symptoms of inefficient braking are observed, then use the self-locking nut (8) to re-adjust the air gap to the value corresponding to Table 1.

Such readjustment may be repeated until the brake linings are completely worn out. When this will occur, a complete armature with brake linings (2) must be replaced.

If the air gap of the brake is correctly adjusted and despite of it the brake does not operate properly (the brake fails to release), it may be caused by:

- the electromagnet (1): burned coil or defected output cable (10),
- rectifying circuit (installed in the electric motor terminal box).

The above mentioned subassemblies should be checked and defected part replaced.

Table 1:

TYPE	H-63	H-71	H-80	H-90	H-100	H-112	H-132	H-160
Nominal Gap „a”	0.2 ±0,05	0.2 ±0,05	0.2 ±0,05	0.2 ±0,05	0.2 ±0,1	0.2 ±0,1	0.2 ±0,1	0.2 ±0,1

EC declaration of conformity according to EC Machinery Directive 2006/42/EC

We herewith declare,

Wood-Mizer Industries sp. Z O.O.
114 Nagorna street, 62-600 Kolo; Poland.

That the following described machine in our delivered version complies with the appropriate basic safety and health requirements of the EC Machinery Directive 2006/42/EC based on its design and type, as brought into circulation by us. In case of alteration of the machine, not agreed by us, this declaration is no longer valid.

Designation of the machine:	Twin Vertical Saw
TYPE:	TVS
Models	TVSE15S; TVSE11S; TVSE15S-FT; TVSE11S-FT; TVSE15S-SC; TVSE11S-SC
No. of manufacturer:
Applicable EC Directives:	EC Machinery Directive 2006/42/EC EC Low-Voltage Directive 73/23/EEC EC Electromagnetic Compatibility Directive 2004/108/EC
Applicable Harmonized Standards:	EN ISO 12100-1; EN 12100-2; EN 1807-4 ; EN 60204-1;
Notified Body according to annex IV :	TUV Product Service GmbH Gottlieb-Daimler Strasse 7 70794 Filderstadt
Responsible for:	EC type examination
Responsible for Technical Documentation:	Roman Frontczak / R&D Director
Date/Authorized Signature:	18. 08. 2011 
Title :	R&D Director