

Single Head Resaw SHR-F

Safety, Operation, Maintenance & Parts Manual

SHRE11S-F
SHRE15S-F

rev.A1.01
rev.A1.01



Safety is our #1 concern! Read and understand all safety information and instructions before operating, setting up or maintaining this machine.

January 2005

Form #1000

Table of Contents

Section-Page

SECTION 1	SAFETY	1-1
1.1	Safety Symbols.....	1-1
1.2	Safety Instructions.....	1-2
SECTION 2	OPERATION	2-1
2.1	Control Overview.....	2-1
2.2	Resaw Setup.....	2-3
2.3	Replacing The Blade.....	2-5
2.4	Tensioning The Blade.....	2-7
2.5	Tracking The Blade.....	2-8
2.6	Machine Start.....	2-10
2.7	Blade Height Location Setting.....	2-13
2.8	Guide Fence Adjustment.....	2-14
2.9	Water Lube Operation.....	2-15
2.10	Operation Procedure.....	2-16
SECTION 3	MAINTENANCE	3-1
3.1	Wear Life.....	3-1
3.2	Blade Guides.....	3-2
3.3	Sawdust Removal.....	3-2
3.4	Vertical Mast.....	3-2
3.5	Miscellaneous Lubrication.....	3-3
3.6	Blade Tensioner.....	3-4
3.7	Belts.....	3-4
3.8	Drive Belt Adjustment.....	3-5
SECTION 4	ALIGNMENT	4-1
4.1	Alignment Procedures.....	4-1
4.2	Blade Installation And Tracking.....	4-2
4.3	Blade Wheel Alignment.....	4-4
4.4	Saw Head Adjustment.....	4-9
4.5	Blade Guide Arm Vertical Adjustment.....	4-10
4.6	Blade Guide Arm Horizontal Adjustment.....	4-12
4.7	Aligning the Blade Guides.....	4-14
4.8	Blade Deflection.....	4-15
4.9	Blade Guide Vertical Tilt Adjustment.....	4-16
4.10	Blade Guide Spacing.....	4-18
4.11	Blade Guide Horizontal Tilt Adjustment.....	4-19
4.12	Blade Height Scale Adjustment.....	4-20
4.13	Infeed And Outfeed Tables.....	4-21
SECTION 5	SPECIFICATIONS	5-1
5.1	Overall Dimensions.....	5-1
5.2	Cutting Capacity.....	5-3
5.3	Blade Motor Specifications.....	5-4
5.4	Electrical Diagram, CE version.....	5-5

Table of Contents

Section-Page

5.5	Electrical Diagram, African version.....	5-6
5.6	Electrical Component Layout Diagram.....	5-7
5.7	Electrical Component List, SHR-F.....	5-8
5.8	V-Belt Sizes.....	5-9
5.9	Dust Extractor Specifications.....	5-9
SECTION 6 REPLACEMENT PARTS		6-1
6.1	How To Use The Parts List.....	6-1
6.2	Sample Assembly.....	6-1
6.2	Blade Guide Assembly, Idle Side.....	6-2
6.3	Blade Guide Assembly, Drive Side.....	6-3
6.4	Blade Guide Arm Assembly.....	6-5
6.5	Blade Wheel Assembly, Drive Side.....	6-6
6.6	Idle Side Blade Wheel Assembly.....	6-8
6.7	Blade Tensioner Assembly.....	6-10
6.8	Middle Throat Screw.....	6-11
6.9	Water Lube Assembly.....	6-12
6.10	Saw Head Safety Decals.....	6-14
6.11	Blade Housing Cover.....	6-16
6.12	Control Panel.....	6-18
6.13	Saw Head Height Adjustment Screw.....	6-19
6.14	Mast Tilt Adjustment Screw.....	6-20
6.15	Vertical Mast Slide Pads.....	6-21
6.16	Motor Assembly.....	6-23
6.17	Feed Track Assembly (SHR-F).....	6-24
6.18	Hold-Down Roller Assembly, SHR-F.....	6-26
6.19	Guide Fence Assembly, SHR-F.....	6-27
6.20	Infeed, Outfeed & Return Tables.....	6-28
SECTION 7 DC ELECTROMAGNETIC BRAKE		7-1
7.1	Design and Principle of Operation.....	7-1
7.2	Service.....	7-2

SECTION 1 SAFETY

1.1 Safety Symbols

The following symbols and signal words call your attention to instructions concerning your personal safety. Be sure to observe and follow these instructions.



DANGER! indicates an imminently hazardous situation which, if not avoided, will result in death or serious injury.



WARNING! suggests a potentially hazardous situation which, if not avoided, could result in death or serious injury.



CAUTION! refers to potentially hazardous situations which, if not avoided, may result in minor or moderate injury or damage to equipment.



IMPORTANT! indicates vital information.

NOTE: gives helpful information.



Warning stripes are placed on areas where a single decal would be insufficient. To avoid serious injury, keep out of the path of any equipment marked with warning stripes.

1.2 Safety Instructions

NOTE: ONLY safety instructions regarding personal injury are listed in this section. Caution statements regarding only equipment damage appear where applicable throughout the manual.

Observe Safety Instructions



IMPORTANT! Read the entire Operator's Manual before operating the resaw. Take notice of all safety warnings throughout this manual and those posted on the machine. Keep this manual with this machine at all times, regardless of ownership.

Also read any additional manufacturer's manuals and observe any applicable safety instructions including dangers, warnings, and cautions.

Only persons who have read and understood the entire operator's manual should operate the resaw. The resaw is not intended for use by or around children.

IMPORTANT! It is always the owner's responsibility to comply with all applicable federal, state and local laws, rules and regulations regarding the ownership and operation of your Wood-Mizer resaw. All Wood-Mizer resaw owners are encouraged to become thoroughly familiar with these applicable laws and comply with them fully while using the machine.



Wear Safety Clothing



WARNING! Secure all loose clothing and jewelry before operating the resaw. Failure to do so may result in serious injury or death.

WARNING! Always wear gloves and eye protection when handling bandsaw blades. Changing blades is safest when done by one person! Keep all other persons away from area when coiling, carrying or changing a blade. Failure to do so may result in serious injury.

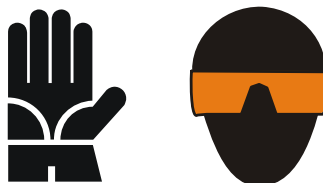

WARNING! Always wear eye, ear, respiration, and foot protection when operating or servicing the resaw.



Keep Resaw And Area Around Resaw Clean



DANGER! Maintain a clean and clear path for all necessary movement around the resaw and lumber stacking areas. Failure to do so will result in serious injury.

Dispose Of Sawing By-Products Properly



IMPORTANT! Always properly dispose of all sawing by-products, including sawdust and other debris.

Check Resaw Before Operation

 **DANGER!** Make sure all guards and covers are in place and secured before operating the resaw. Failure to do so may result in serious injury.



Keep Persons Away

 **DANGER!** Keep all persons out of the path of moving equipment and lumber when operating the resaw. Failure to do so will result in serious injury.

DANGER! Always be sure all persons are out of the path of the blade before starting the motor. Failure to do so will result in serious injury.

 **WARNING!** Allow blade to come to a complete stop before opening the blade housing cover. Failure to do so will result in serious injury.

Keep Hands Away



DANGER! Always shut off the blade motor before changing the blade. Failure to do so will result in serious injury.

DANGER! Motor components can become very hot during operation. Avoid contact with any part of a hot motor. Contact with hot motor components can cause serious burns. Therefore, never touch or perform service functions on a hot motor. Allow the motor to cool sufficiently before beginning any service function.

DANGER! Always keep hands away from moving bandsaw blade. Failure to do so will result in serious injury.

DANGER! Always be aware of and take proper protective measures against rotating shafts, pulleys, fans, etc. Always stay a safe distance from rotating members and make sure that loose clothing or long hair does not engage rotating members resulting in possible injury.



WARNING! Use extreme caution when spinning the blade wheels by hand. Make sure hands are clear of blade and wheel spokes before spinning. Failure to do so may result in serious injury.

Use Proper Maintenance Procedures



DANGER! Make sure all electrical installation, service and/or maintenance work is performed by a qualified electrician and is in accordance with applicable electrical codes.

DANGER! Hazardous voltage inside the electric boxes and at the motor can cause shock, burns, or death. Disconnect and lock out power supply before servicing! Keep all electrical component covers closed and securely fastened during resaw operation.



WARNING! Consider all electrical circuits energized and dangerous.

WARNING! Disconnect and lock out power supply before servicing the resaw! Failure to do so may result in serious injury.

WARNING! Never assume or take the word of another person that the power is off; check it out and lock it out.

WARNING! Do not wear rings, watches, or other jewelry while working around an open electrical circuit.

WARNING! Remove the blade before performing any service to the motor or resaw. Failure to do so may result in serious injury.

1 Safety

Keep Safety Labels In Good Condition

Keep Safety Labels In Good Condition



IMPORTANT! Always be sure that all safety decals are clean and readable. Replace all damaged safety decals to prevent personal injury or damage to the equipment. Contact your local distributor, or call your Customer Service Representative to order more decals.

IMPORTANT! If replacing a component which has a safety decal affixed to it, make sure the new component also has the safety decal affixed.

SECTION 2 OPERATION

2.1 Control Overview

1. Control Panel

See Figure 2-1. The control panel includes switches to start and stop the feed track and the saw head.

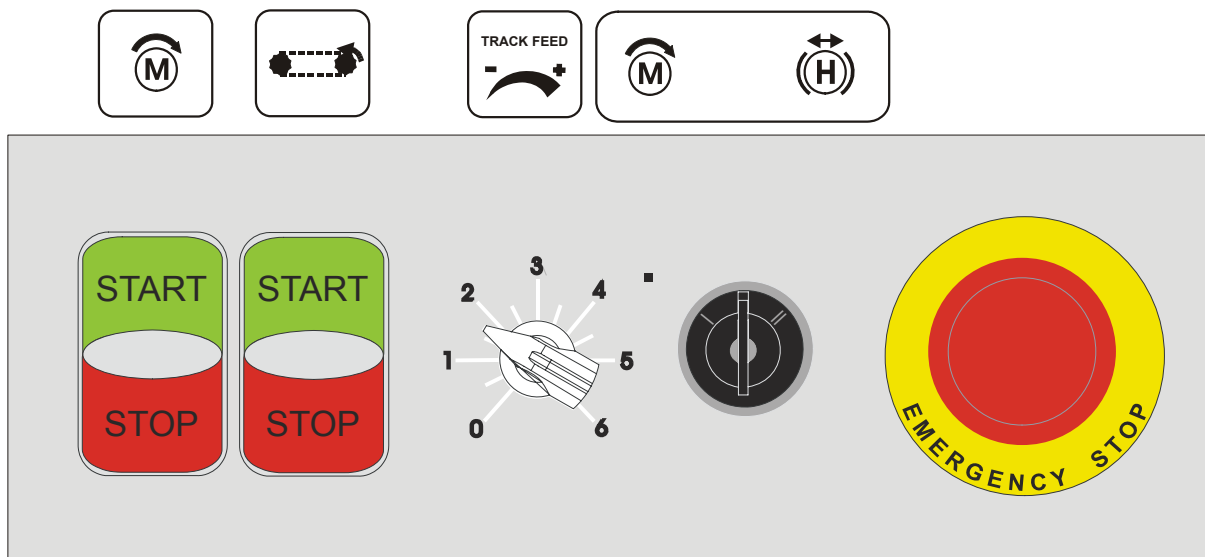





FIG. 2-1 CONTROL PANEL COMPONENTS

2. Blade Drive

 To start the blade motor, turn the key switch to the  position. Then place the START/STOP switch in the START position (press on START) and release the switch. To stop the blade motor, place the START/STOP switch in the STOP position and then release the switch.

3. Feed Track

 To start the feed track, place the START/STOP switch in the START position (press on START) and then release the switch. To stop the feed track, place the START/STOP switch in the STOP position and release.



4. Feed Track Speed Adjustment



The feed track speed switch controls the speed at which the feed track moves. Turn the switch clockwise to increase the speed, counterclockwise to reduce the speed.

5. Key Switch

The key switch has three positions:

- “0” position - all electrical circuits are off,
-  position - all electrical circuits are on,
-  position - releases the motor disk brake, the blade and the track feed motors are off.

6. Emergency Stop

Push the emergency stop button to stop the blade and the track feed motors. Turn the emergency stop clockwise to release the stop. The resaw will not restart until the emergency stop is released.

2.2 Resaw Setup



IMPORTANT! Before starting to use the resaw you have to meet the following conditions:

- Set up the resaw on firm and level ground.
- The resaw can be operated with the sawdust collection system only.
- The resaw can be operated under roof only.
- The resaw can be operated in temperature range from 5° C to 40° C only.
- The resaw operator's position is shown below.

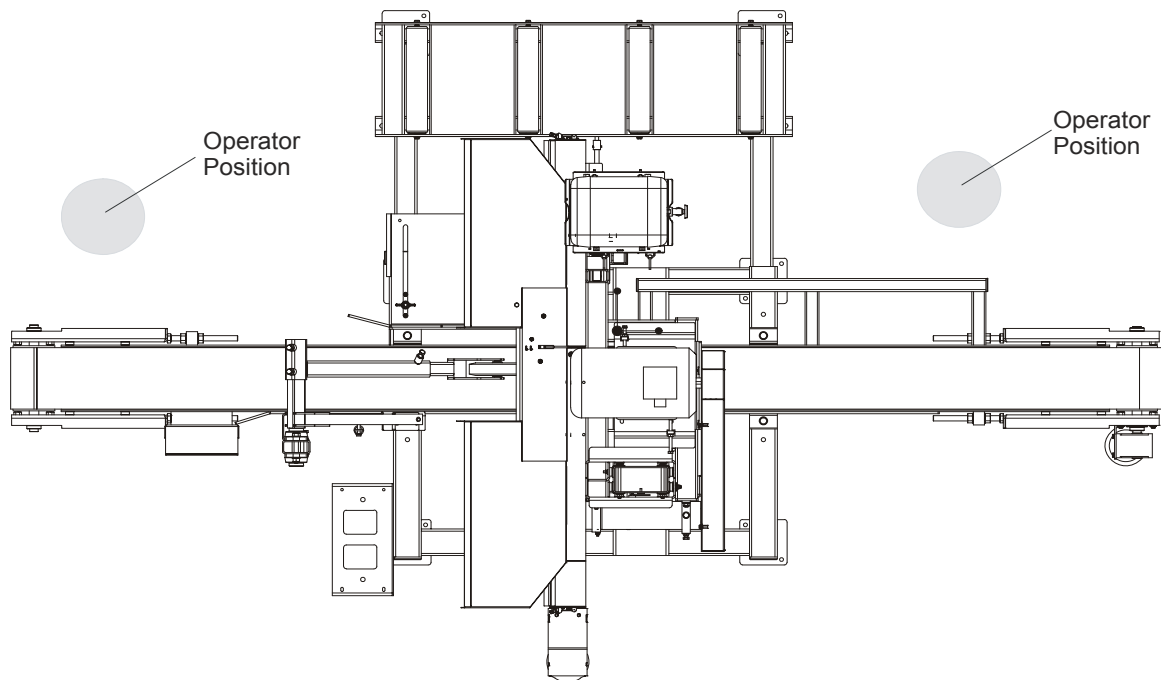

- Have a qualified electrician install the power supply (according to EN 60204 Standard). The power supply must meet the specifications given in the table below.

3-Phase Volts	Fuse Disconnect	Suggested Wire Size
400 VAC	32 Amps	4 mm ² , up to 15 m long

TABLE 2-0



IMPORTANT! When starting the machine for the first time, check that main motor rotation direction is as indicated by the arrow located on the motor body (fan guard). If the rotation direction is incorrect, invert the phases in the phase inverter located in the power socket (electric box). Setting the phases in the phase inverter correctly will ensure correct rotation directions of all sawmill motors.

2.3 Replacing The Blade



DANGER! Always shut off the resaw motor before changing the blade. Failure to do so may result in serious injury.



WARNING! Always wear gloves and eye protection whenever handling bandsaw blades. Changing blades is safest when done by one person! Keep all other persons away from work area when changing blades. Failure to do so may result in serious injury.

Raise the blade housing cover. Turn the blade tension handle to release the blade tension until the wheel is pulled in and the blade is lying loose in the blade housing. Lift the blade out of the blade housing.

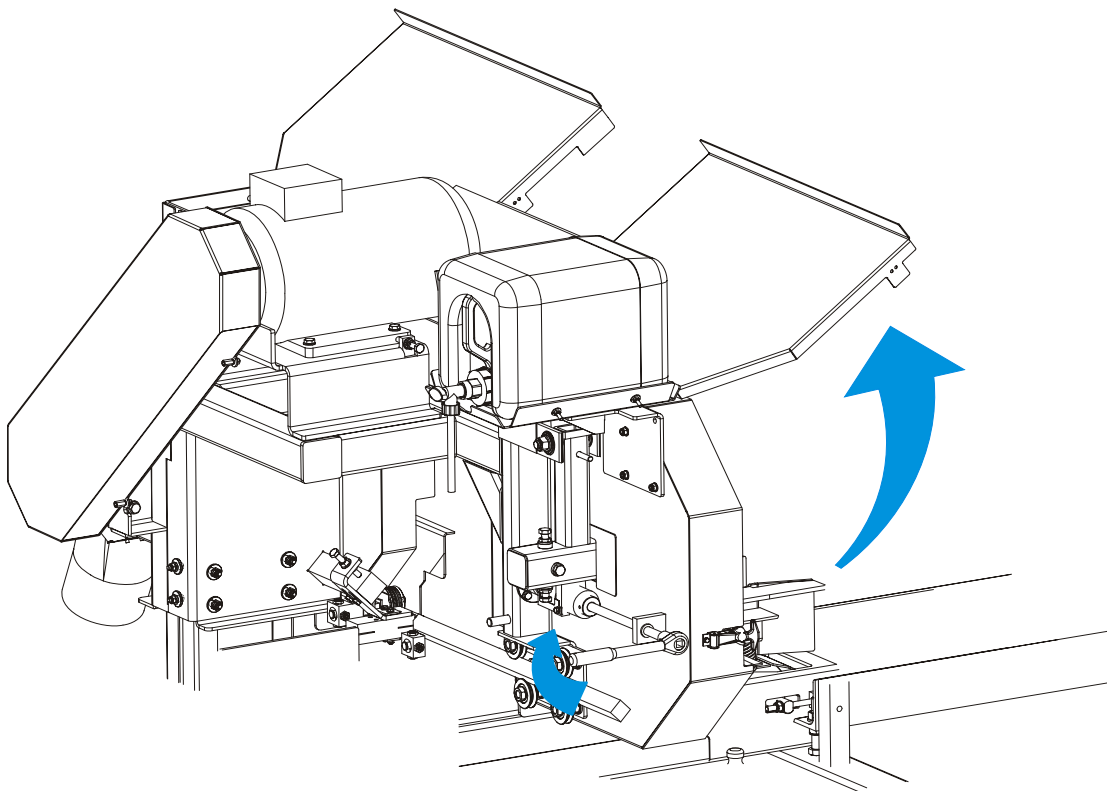

Install a new blade around the two blade wheels so that the teeth located between the blade guide assemblies point to the drive side of the machine. Make sure the teeth are pointing the correct direction.

Position 1 1/4" wide blades on the wheels so the gullet is 3.0 mm (± 1.0 mm) out from the front edge of the wheel.

2 *Replacing The Blade*

Close the blade housing cover.

Next, tension the blade as described in the following instructions.

2.4 Tensioning The Blade

See **Figure 2-2**. Place the provided ratchet on the blade tensioner shaft. Turn the ratchet clockwise until the outside face of the rubber spring washer is even with the indicator (see the figure below). Check the blade tension occasionally when adjusting the cant control or while cutting and adjust if necessary. As the blade and belts heat up and stretch, the blade tension will change. Also, ambient temperature changes can cause tension to change.

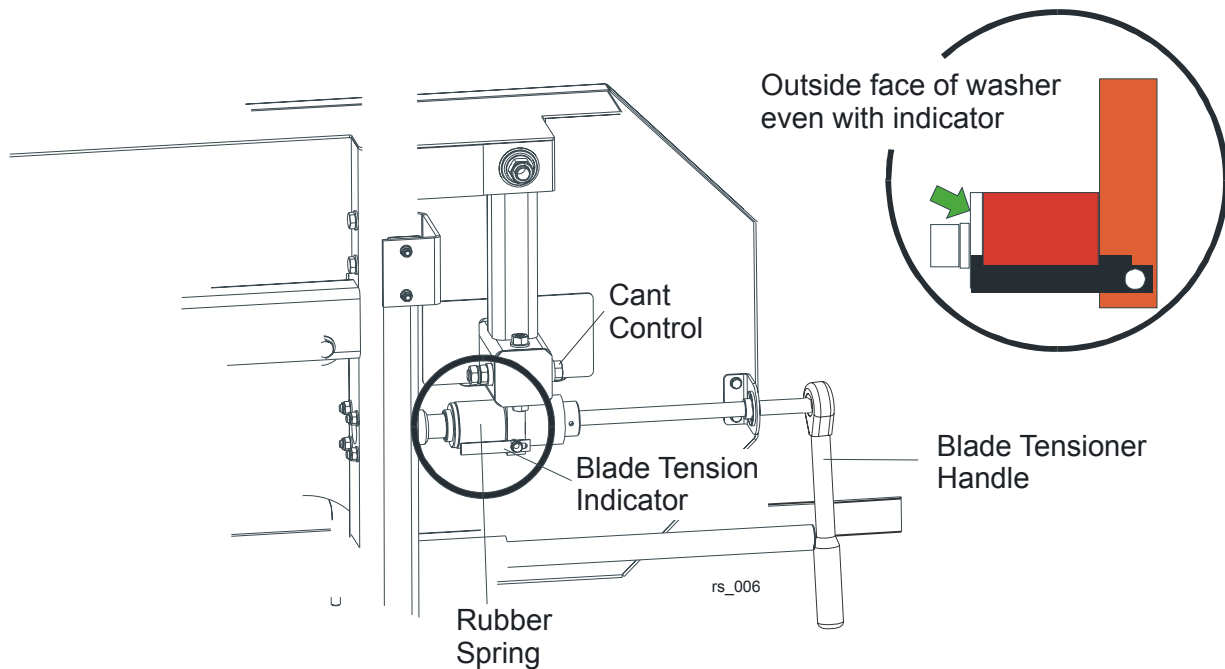

FIG. 2-2



CAUTION! Release the blade tension when the resaw is not in use.

2.5 Tracking The Blade

1. Open the blade housing cover.
2. Turn the key switch to the "H" position.



3. Manually spin one of the blade wheels until the blade positions itself on the blade wheels.
4. Check that the blade is properly positioned on the blade wheels.

See **Figure 2-3**. 1 1/4" wide blades should be placed on the blade wheels so that the

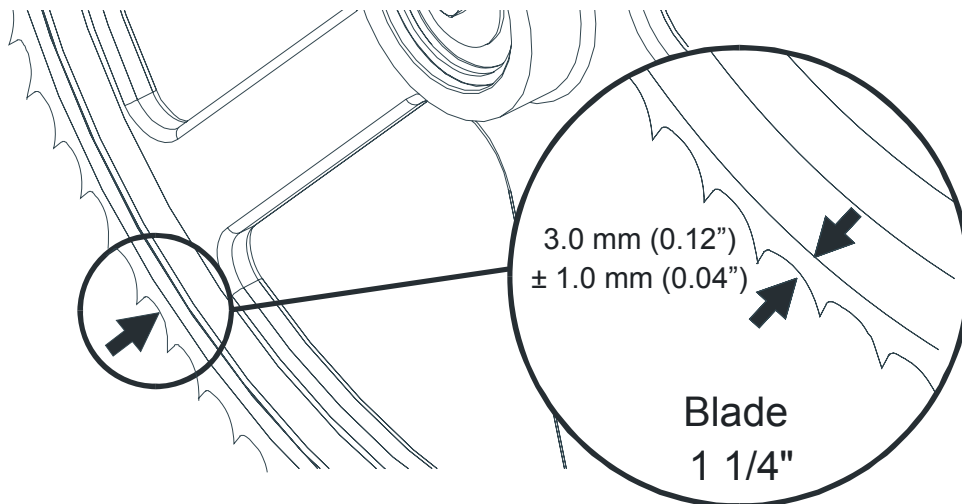

FIG. 2-3

gullet is 3.0 mm (0.12") ± 1.0 mm (0.04") out from the front edge of the wheel.

5. Use the cant adjustment bolt, shown in **Figure 2-2**, to adjust where the blade travels on the blade wheels.

To move the blade out on the blade wheel, turn the cant adjustment bolt clockwise. To move the blade in on the blade wheel, turn the bolt counterclockwise.

6. Adjust the blade tension if necessary to compensate for any changes that may have occurred while adjusting the cant control.
7. Close the blade housing cover.



CAUTION! Make sure all guards and covers are in place and secured before operating or towing the resaw. Failure

to do so may result in serious injury. Be sure the blade housing cover is in place and secured.

NOTE: After aligning the blade on the wheels, always check the blade guide spacing and location.

2.6 Machine Start

 **DANGER!** Before starting the resaw, perform these steps to avoid injury and/or damage to the equipment:

- Close the blade housing cover and replace any guards removed for service.
- Check the feed track and remove all loose objects such as tools, wood, etc.
- Check that the blade is properly tensioned.
- Make sure all persons are a safe distance from the machine.
- Check that the emergency stops are released.

NOTE: The resaw will not start if either of the emergency stops is on.

Before starting the saw head, check that the main power switch servicing the resaw is on.

See Figure 2-4. Start the blade motor. To do this, turn the key switch to the  position and then push the Blade Start button on the control panel (see the figure below). The motor should start and the blade should start spinning.

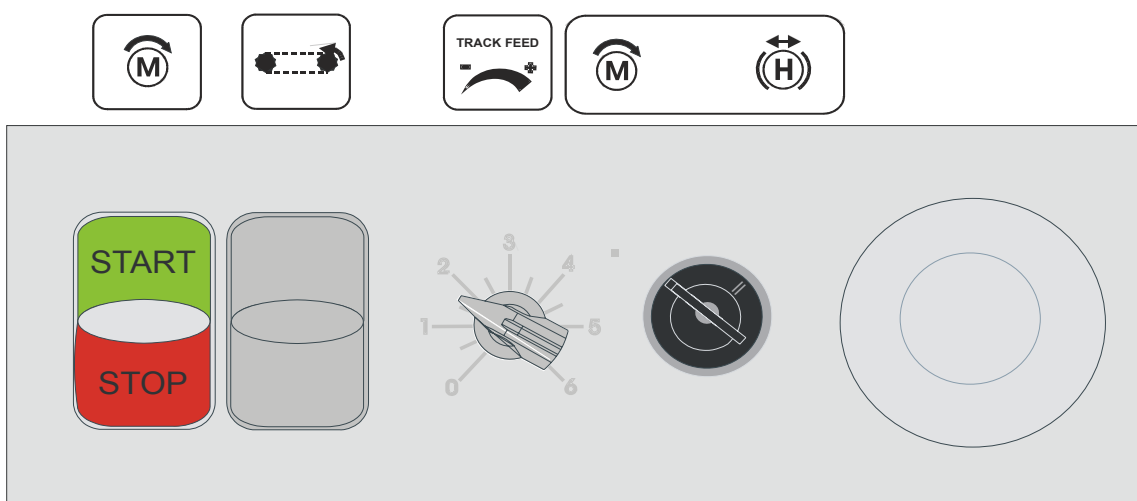

FIG. 2-4

To stop the blade motor, push the Blade/Track Stop button shown in the figure above. The blade motor also may be stopped by pushing either of the emergency stop buttons.

If either of the emergency stops has been used to stop the blade motor, rotate the switch

clockwise before restarting the saw head. The saw head cannot be restarted until the emergency stop button is released.

See Figure 2-5. After the saw head has been successfully started, the feed track can be

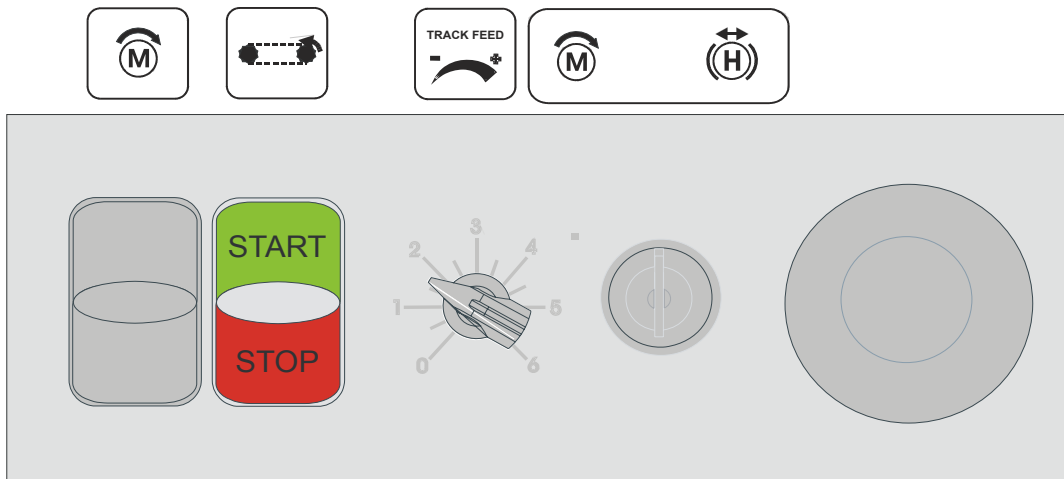

FIG. 2-5

started. To start the track feed motor, push the Track Start button shown in Figure 2-5.

The feed track can be stopped by pressing either the Track Stop button, shown in Figure 2-5, or one of the emergency stop buttons. The emergency stop will also stop the blade motor.

NOTE: The feed track cannot be started if the blade motor is not started.

See Figure 2-6. The speed at which the feed track moves is adjustable. The feed track

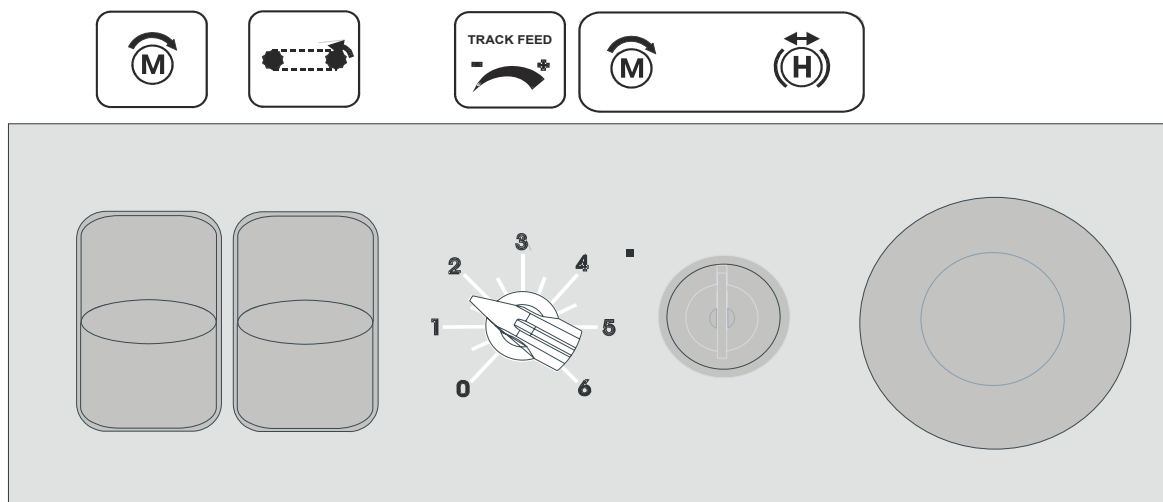

FIG. 2-6

speed switch, located on the control panel, allows the operator to adjust the feed rate from 0 to ca. 30 m per minute.

Turn the switch clockwise to increase the feed rate, counterclockwise to slow the feed rate down.

Factors that will determine what feed rate you can use include:

- Width of material to be cut. Eight-inch material will require a slower feed rate than 1" material.
- Hardness of material to be cut. Some woods that are seasoned or naturally very hard will require slower feed rates.
- Sharpness of blades. Dull or improperly sharpened blades will require slower feed rates than sharp and properly maintained blades.
- Off-bearing capability. Your ability to feed end-to-end will also determine what feed rate you can use.

2.7 Blade Height Location Setting

1. Install a blade if needed and check for correct blade tension. ([Section 2.4](#))
2. Set the saw head at the desired height. (The blade height scale shows the height of the blade above the feed track.)

See Figure 2-7. To raise or lower the saw head, use the acme screw as shown in the figure. Turn the screw clockwise to raise the saw head, counterclockwise to lower the saw head.

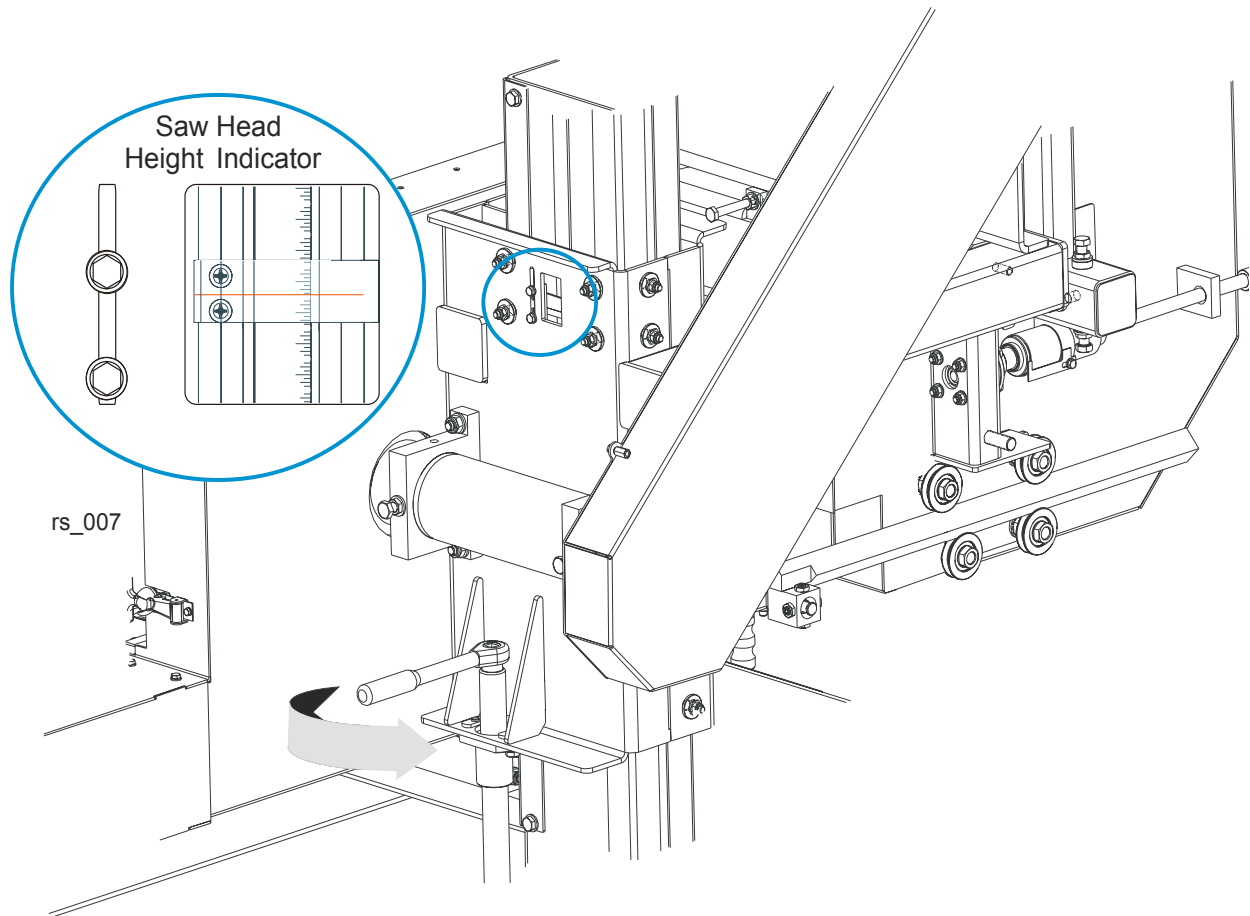

FIG. 2-7

2.8 Guide Fence Adjustment

Patrz rysunek 2-8. Loosen the wing nuts. Move the guide fence to the desired cant width.

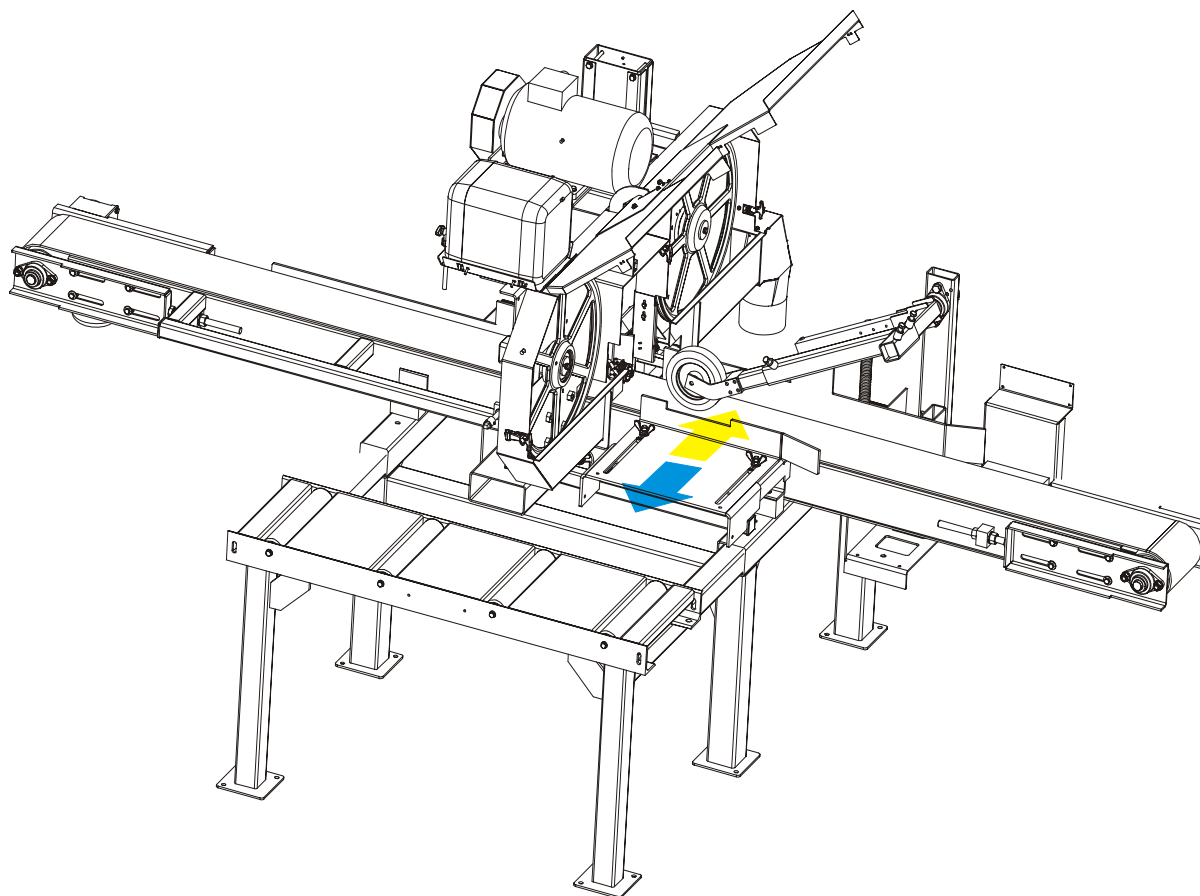

FIG. 2-8

2.9 Water Lube Operation

See **Figure 2-9**. The Water Lube System keeps the blade clean. Water flows from a 5-gallon (18.9 liter) bottle through a hose to the blade guide where the blade enters the log. A valve in the bottle cap controls the amount of water flow.

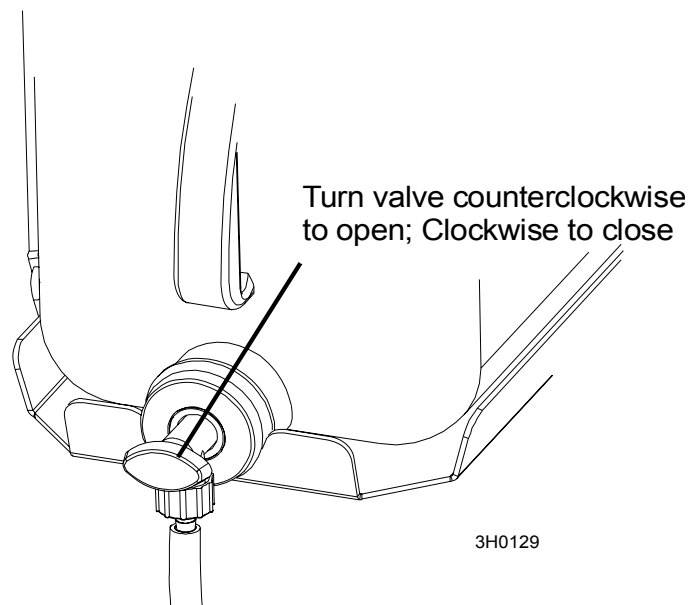

FIG. 2-9

Not all types of wood require the use of the Water Lube System. When it is needed, use just enough water to keep the blade clean. This saves water, and lowers the risk of staining the boards with water. Usual flow will be 1-2 gallons (3.8-7.6 liters) per hour (on average, the bottle content is sufficient for 4-hour-long cutting). A squirt of liquid dishwashing detergent in the water bottle will help clean the blade when cutting wood with a high sap content. Before you start cutting, check the water level in the bottle.



WARNING! Use **ONLY** water with the water lube accessory. Never use flammable fuels or liquids. If these types of liquids are necessary to clean the blade, remove it and clean with a rag. Failure to do so may result in serious injury or death.

Before removing the blade, start the blade motor with the START button. Let the blade spin with water running on it for about 15 seconds. This will clean the blade of sap buildup. Wipe the blade dry with a rag before storing or sharpening.

If you are sawing in freezing temperatures, remove the water lube bottle from the resaw when done sawing and store it in a warm place. Blow any remaining water from the water lube hose.

2.10 Operation Procedure

1. Install a blade if necessary.



WARNING! Always wear gloves and eye protection when handling bandsaw blades. Changing blades is safest when done by one person! Keep all other persons away from area when coiling, carrying or changing a blade. Failure to do so may result in serious injury.

2. Close the blade housing cover.
3. Tension the blade as described in [Section 2.4](#).
4. Spin the blade wheel by hand.



WARNING! Use extreme caution when spinning the blade wheel by hand. Make sure hands are clear of blade and wheel spokes before spinning. Failure to do so may result in serious injury.

5. Check alignment of the blade on the blade wheels and blade guides. Adjust as necessary.
6. Raise or lower the saw head to the desired setting.
7. Adjust the clamp roller guide to the width of material to be cut.



DANGER! Make sure all guards and covers are in place and secured before operating the resaw. Failure to do so may result in serious injury.

8. Perform pre-start check.
9. Start the blade motor.
10. Using the feed track speed switch, set the feed rate as desired.



DANGER! Always be sure all persons are out of the path of the blade before starting the motor. Failure to do so will result in serious injury.



WARNING! Always wear eye, ear, respiration and foot protection when operating or servicing your resaw.

11. Place the test material on the feed track and start the feed track.



DANGER! Always be aware of and take proper protective measures against rotating shafts, pulleys, fans, etc. Always stay a safe distance from rotating members and make sure that loose clothing or long hair does not engage rotating members resulting in possible injury.

12. Shut off the blade and feed track. Measure the finished material and adjust the saw head up or down as necessary. Repeat with the test material until the desired finished dimension is obtained.
13. Restart the blade and feed track.
14. Place material on the infeed table. Return unfinished material to be re-fed into the resaw, i.e. place it on the return table.
15. Monitor blade tension as operation continues. Adjust blade tension if required.
16. If material jam occurs, stop the blade motor and feed track.



WARNING! Allow blade to come to a complete stop before servicing. Failure to do so will result in serious injury.

17. After operation is complete, shut off the blade motor and feed track.
18. Release blade tension if done sawing for the day.



CAUTION! Remove tension from the blade when the resaw is not in use.

SECTION 3 MAINTENANCE

This section lists the maintenance procedures that need to be performed.



This symbol identifies the interval (hours of operation) at which each maintenance procedure should be performed.

Be sure to refer to the motor manual for maintenance procedures concerning the blade motor.

3.1 Wear Life

See Table 3-1. This chart lists estimated life expectancy of common replacement parts if proper maintenance and operation procedures are followed. Due to the many variables which exist during resaw operation, actual part life may vary significantly. This information is provided so that you may plan ahead in ordering replacement parts.

Part Description	Estimated Life
B57 Blade Wheel Belts	500 hours
Blade Guide Rollers	1000 hours
Drive Belt	1250 hours

TABLE 3-1

3.2 Blade Guides

1. Check the rollers for performance and wear every blade change. Make sure the rollers are clean and spinning freely. If not, rebuild them. Replace any rollers which have worn smooth or have become cone shaped. See the Parts manual for blade guide rebuild kits and complete roller assemblies.

3.3 Sawdust Removal

1. Remove the excess sawdust from the blade wheel housing and sawdust chute every blade change.

3.4 Vertical Mast



Clean the vertical mast angles, wipe them dry and lubricate with a WD40 oil every 50 hours of operation.



CAUTION! Never use grease on the mast angles as it will collect sawdust.

3.5 Miscellaneous Lubrication

1. Apply a thin film of a lithium grease to the blade guide arm to help prevent it from rusting.
50
2. Lubricate the feed track chain with an easily penetrating oil such as WD-40.
50



CAUTION! Never apply grease to the feed track chain.
It causes sawdust buildup in chain links.

3. Make sure all safety warning decals are readable. Remove sawdust and dirt. Replace any damaged or unreadable decals immediately. Order decals from your Customer Service Representative.
4. Lubricate the two acme screws (screws for saw head tilting and raising or lowering) with a lithium grease every 50 hours of operation.
50

3.6 Blade Tensioner

1. Grease the screw on the blade tensioner shaft with a lithium grease every fifty hours of operation, but at least once a week.

50

See Figure 3-1.

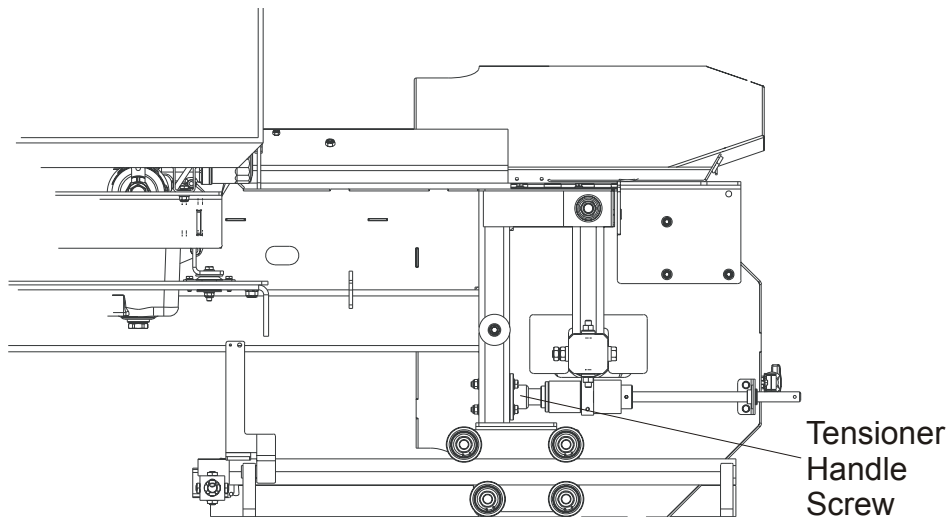

20_006

FIG. 3-1

3.7 Belts

1. Check the blade wheel belts for wear every 50 hours of operation. Replace as needed.
2. Periodically check all belts for wear. Replace any damaged or worn belts as needed.

50

3.8 Drive Belt Adjustment

WARNING! Do not for any reason adjust the drive belt with the motor running. Doing so may result in serious injury.

See **Table 3-2**. Check the drive belt tension after the first 20 hours, and every 50 hours thereafter. See the table below for drive belt tension specifications for your resaw.

Motor	Belt Tension
E11	7/16" (11mm) deflection with 8 lbs. (3.6 KG) of deflection force
E15	7/16" (11mm) deflection with 16 lbs. (7.2 KG) of deflection force

TABLE 3-2

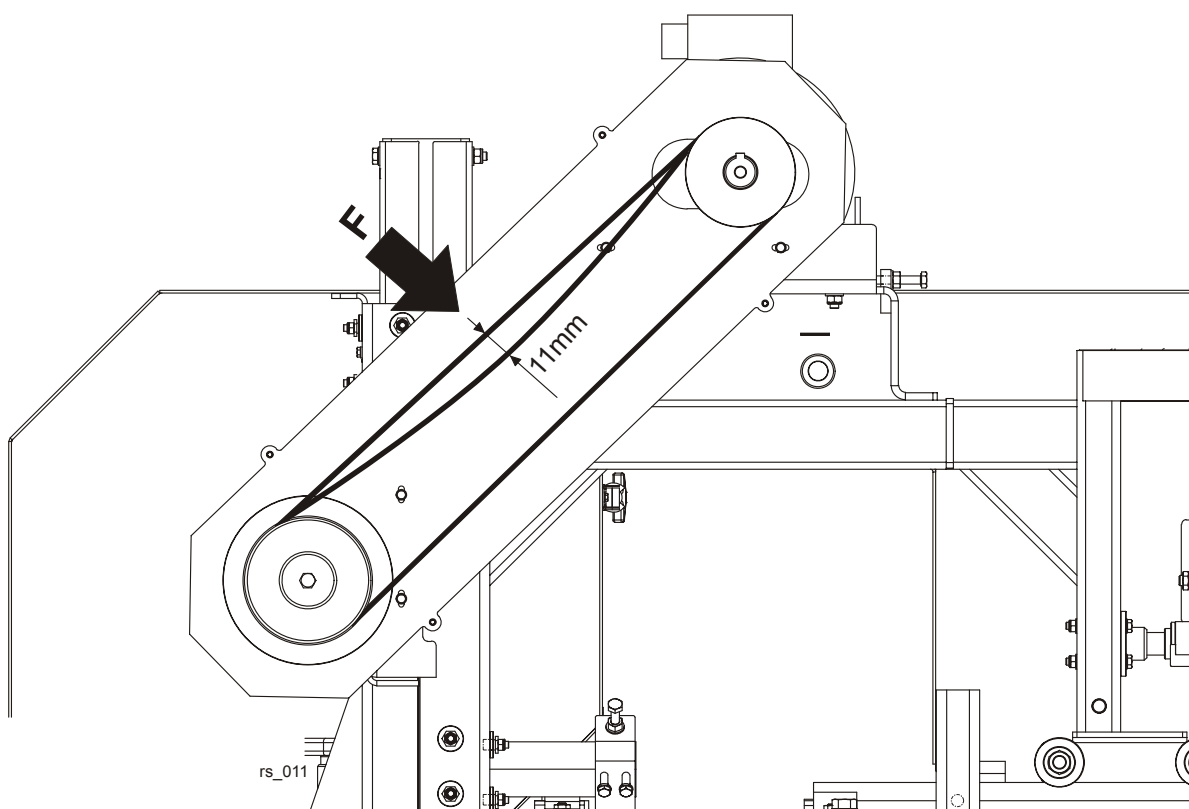

FIG. 3-1

To adjust the drive belt tension:

1. Remove the drive belt guard.
2. Loosen the four motor mounting bolts (see Figure 3-3).
3. Loosen one of the adjustment bolts, shown in Figure 3-3, and turn the other until the belt has proper deflection. (To increase the belt tension, you must loosen the right bolt and

turn appropriately the left one.) **NOTE:** Be sure to adjust the bolts evenly so the motor remains in alignment.

4. Tighten the four motor mounting bolts.

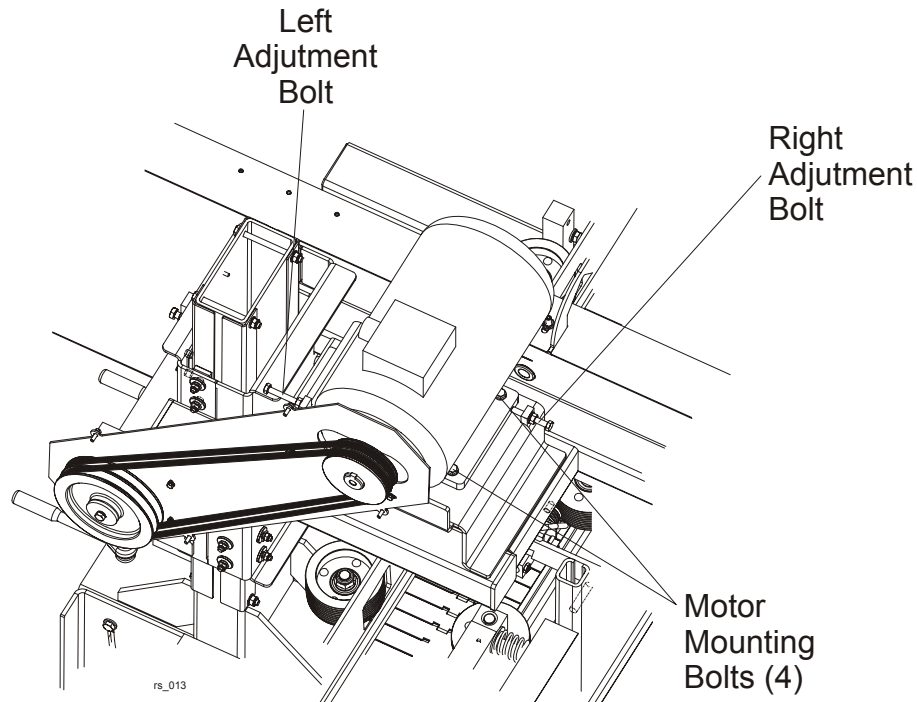

FIG. 3-1



Periodically check the belt for wear. Replace if damaged or worn.

See Figure 3-2. Keep the motor and drive pulleys aligned to prevent premature belt wear. To align the motor pulley to the drive pulley, loosen the set screw in the motor pulley groove and slide the motor pulley on the shaft until it is in line with the drive pulley.

3

MAINTENANCE

Drive Belt Adjustment

After performing the alignment, make sure the drive belt tension has not been changed.

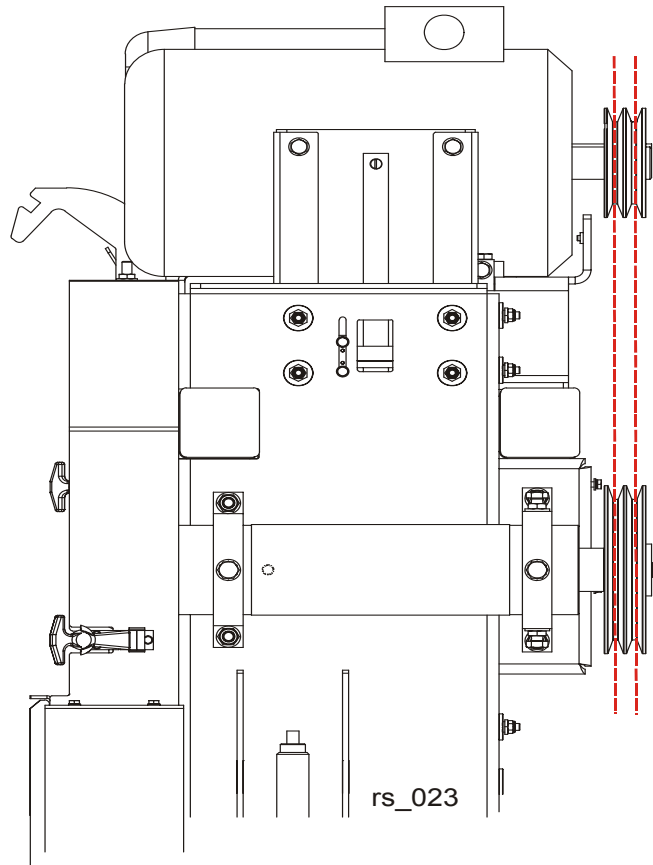

FIG. 3-2

SECTION 4 ALIGNMENT

4.1 Alignment Procedures

The Wood-Mizer resaw is factory aligned. This section includes instructions on how to realign the resaw completely. Be scrupulous when performing all alignment steps as resaw alignment determines the accuracy of your cuts. The alignment procedure should be performed approximately every 1500 hours of operation.

Routine Alignment Procedure:

1. Install and track the blade ([See Section 4.2](#)).
2. Check and adjust the vertical alignment of the blade guide arm ([See Section 4.5](#)).
3. Check and adjust the horizontal alignment of the blade guide arm ([See Section 4.6](#)).
4. Check and adjust the vertical angle of the blade guides ([See Section 4.9](#)).
5. Check and adjust the horizontal angle of the blade guides ([See Section 4.11](#)).
6. Check and adjust the spacing between the blade guide flanges and the back of the blade ([See Section 4.10](#)).
7. Check that the blade height scale accurately displays the actual distance from the bottom of the blade to the feed track and adjust if necessary ([See Section 4.13](#)).

Complete Alignment Procedure:

Perform all steps in this section to completely realign the resaw.

4.2 Blade Installation And Tracking

See Figure 4-1. Install a blade and apply the proper tension as shown below. [See Section 2.4](#)

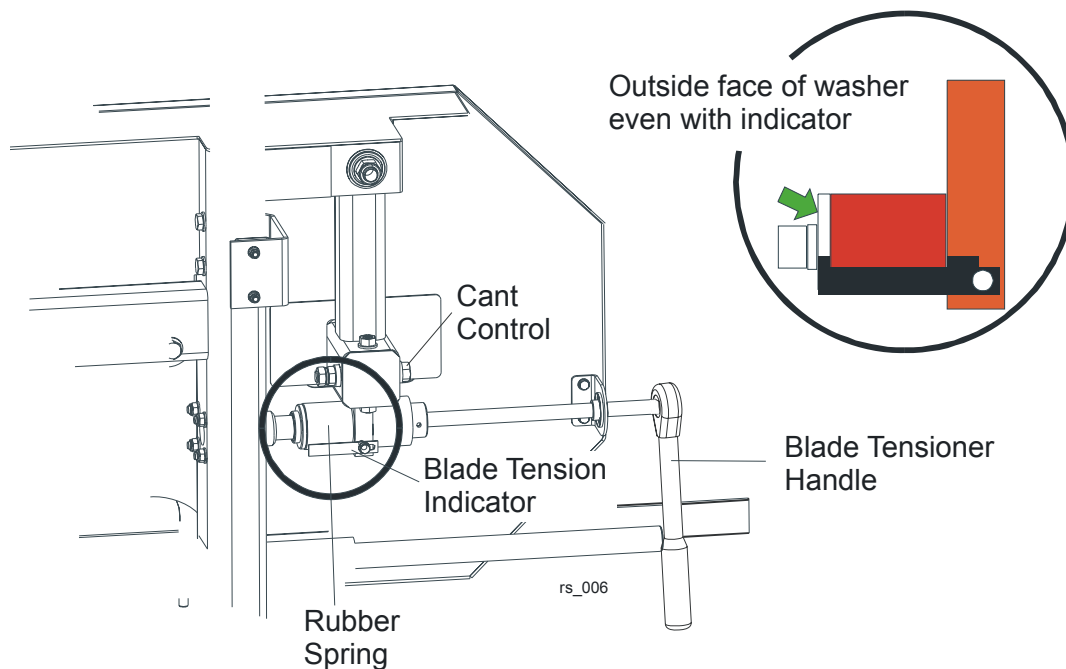

FIG. 4-1

1. Turn the key switch to the "H" position.

(H)

2. Open the blade housing cover.
3. Manually spin one of the blade wheels until the blade positions itself on the wheels.

See Figure 4-2. The blade wheels should be adjusted so that the gullet of 1 1/4" blades rides 3.0 mm (0.12") out from the front edge of the wheels (± 1.0 mm [0.04"]). The gullet of 1 1/2" blades should ride 4.5 mm (0.18") from the front edge of the wheels (± 1.0 mm

[0.04"]). Do not let the teeth ride on the belt.

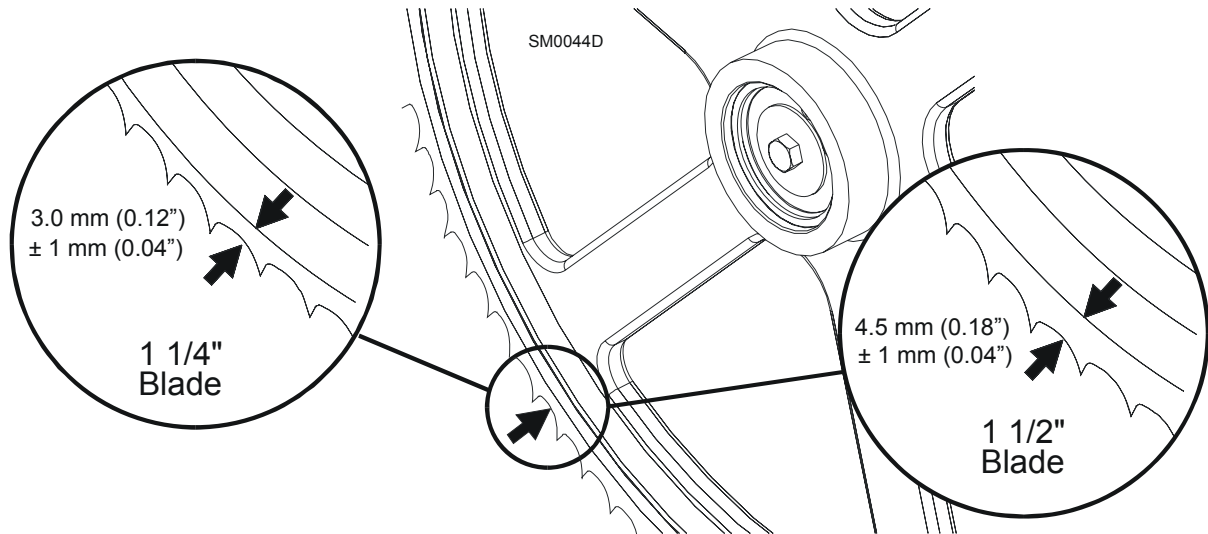

FIG. 4-2

To adjust where the blade travels on the idle-side blade wheel, use the cant control shown in **Figure 4-7**.

To move the blade out on the blade wheel, turn the cant adjustment bolt clockwise. To move the blade in on the blade wheel, turn the bolt counterclockwise.

Some adjustment in blade tension may be needed to compensate for adjustments made with the cant control.

Adjustment with the cant control is usually all that is required to track the blade properly on both blade wheels. The drive-side blade wheel will usually not have to be adjusted. If necessary, the drive-side wheel can be adjusted as follows:

Locate the nuts and the clamping screws located on the drive-side of the cutting head. If the blade is too far forward on the wheel, turn the screw located on the inside of the head counterclockwise and turn the screw located on the outside of the head clockwise. Make sure to tighten the nuts against the shaft housing when adjustment is complete.

4.3 Blade Wheel Alignment

The blade wheels should be adjusted so they are level in the vertical and horizontal planes. If the blade wheels are tilted up or down, the blade will want to travel in the tilted direction. If the blade wheels are tilted horizontally, the blade will not track properly on the wheels.

1. Use the blade guide alignment tool to check the vertical alignment of each blade wheel. Attach the tool to the blade near the inner blade guide mount. Be sure the tool does not rest on a tooth or burr, and is lying flat against the blade.

See Figure 4-3.

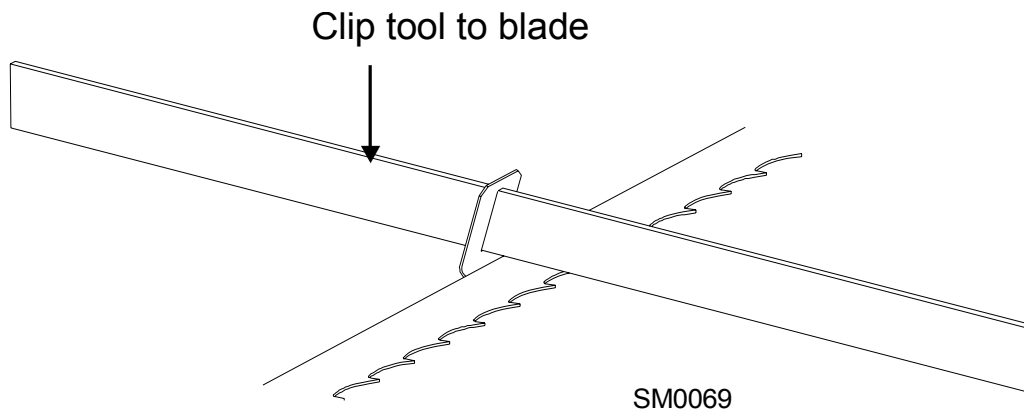

FIG. 4-3

2. Measure from the bottom of the tool to the top of the feed track.
3. If the two measurements differ by more than (± 1.0 mm), adjust the vertical tilt of the drive-side blade wheel.

See Figure 4-4. Use the vertical adjustment screws (marked with the blue and yellow arrows in the figure below) to adjust the drive-side blade wheel. Before adjusting the wheel, loosen the drive belt using the adjustment bolts marked with the orange arrows in the figure. Loosen the jam nut and the hex socket head screw marked with the red arrow in the figure and adjust the wheel with the vertical adjustment screws. To tilt the wheel down, loosen the top adjustment screw one quarter turn. Loosen the jam nut on the bottom adjustment screw and tighten the screw. Tighten the top and bottom jam nuts. To tilt the wheel up, loosen the bottom adjustment screw one quarter turn. Loosen the jam nut on the top adjustment screw and tighten the screw. Tighten the top and bottom jam nuts. Tension the drive belt properly ([See Section 3.8](#)).

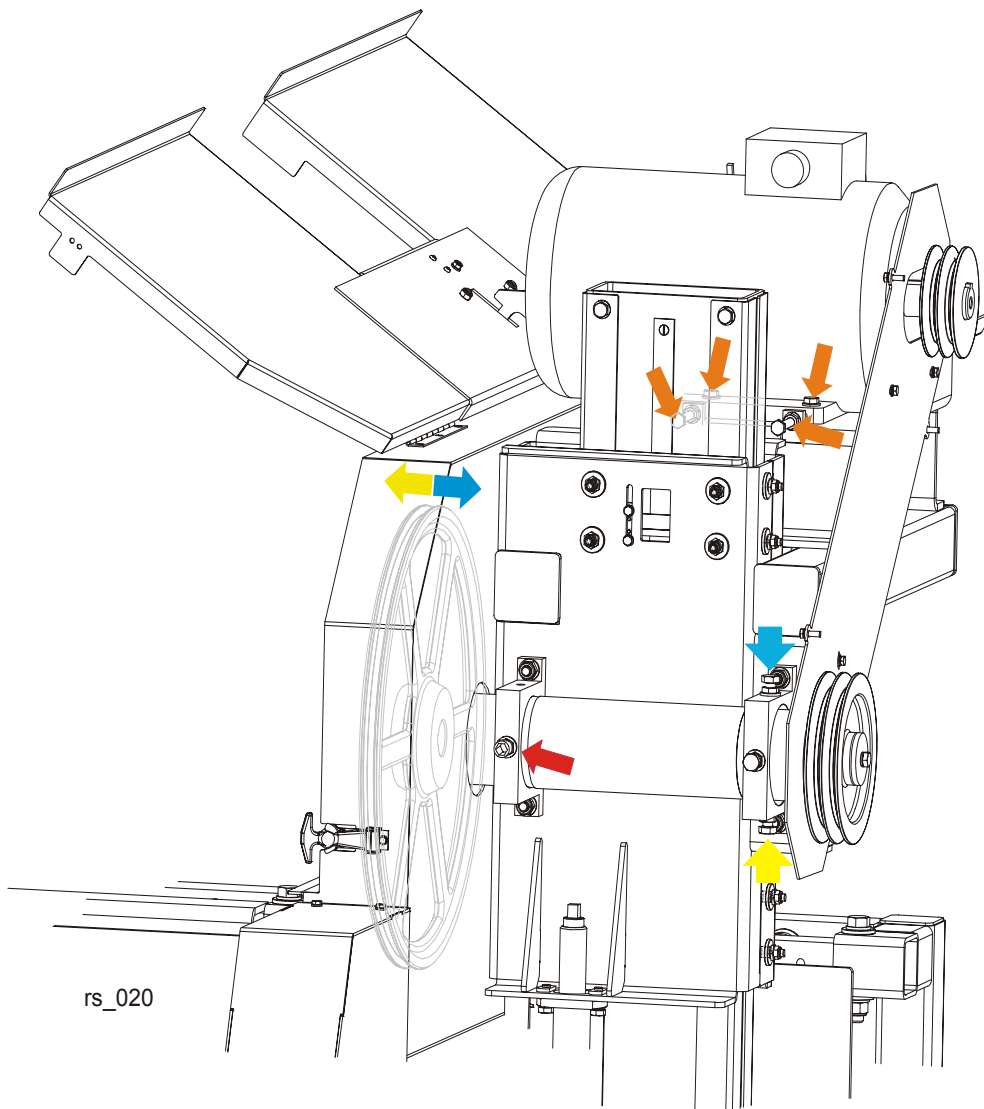

FIG. 4-4

4

Blade Wheel Alignment

4. Recheck the vertical tilt of the drive-side blade wheel with the blade guide alignment tool. Readjust the blade wheel as necessary until the front and rear of the tool are the same distance from the feed track (± 1.0 mm).
5. Remove the tool from the blade and reattach it near the outer blade guide assembly.
6. Measure from the tool to the feed track at both ends of the tool. If the measurements at the front and rear ends of the tool differ by more than (± 1.0 mm), adjust the vertical tilt of the idle-side blade wheel.

See Figure 4-5. Use the vertical adjustment screws to adjust the idle-side blade wheel. To tilt the wheel up, loosen the bottom adjustment screw one quarter turn. Loosen the jam nut on the top adjustment screw and tighten the screw. Tighten the top and bottom jam nuts.

To tilt the wheel down, loosen the top adjustment screw one quarter turn. Loosen the jam nut on the bottom adjustment screw and tighten the screw. Tighten the top and bottom jam nuts.

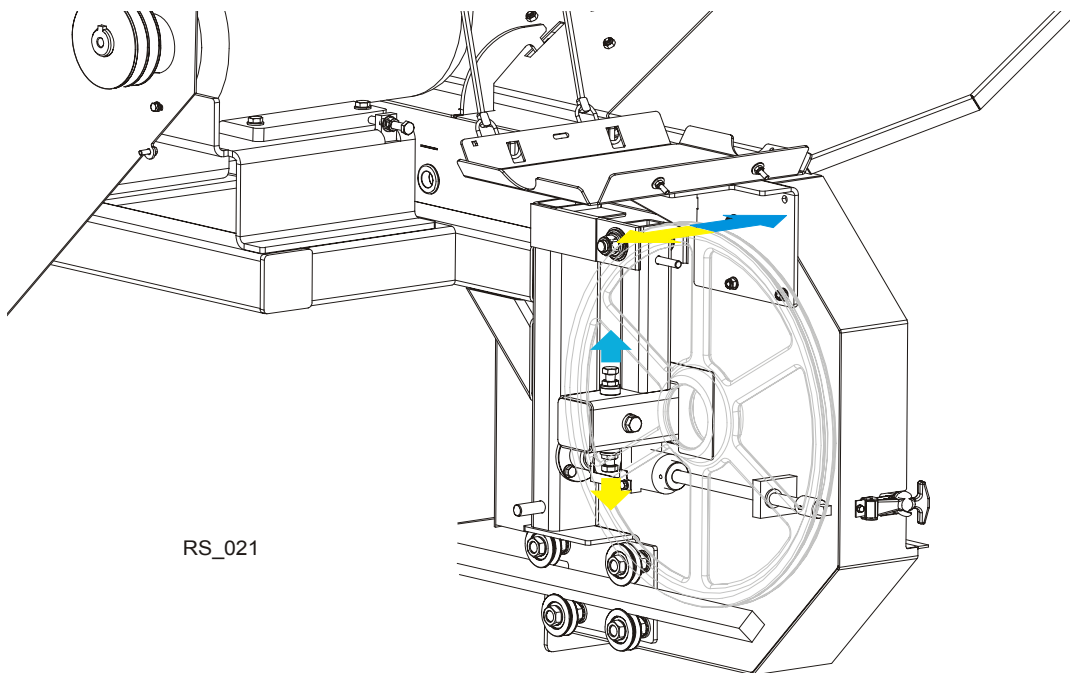

FIG. 4-5

7. Recheck the vertical tilt of the idle-side blade wheel with the blade guide alignment tool. Readjust the blade wheel as necessary until the front and rear of the tool are the same distance from the feed track.

8. Check the position of the blade on the idle-side blade wheel.

See Figure 4-6. The horizontal tilt of the blade wheel should be adjusted so that the gullet of an 1-1/4" blade is 3.0 mm out from the front edge of the wheel (± 1.0 mm).

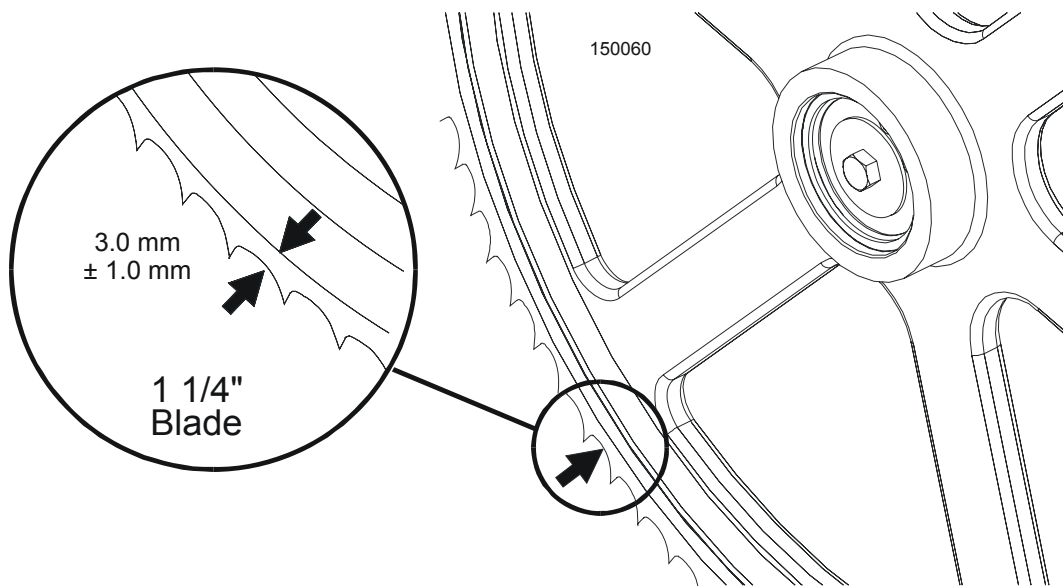

FIG. 4-6

See Figure 4-7. Use the cant control adjustment to adjust the idle-side blade wheel. If the blade is too far forward on the wheel, turn the cant control counterclockwise. If it is too far back on the wheel, turn the cant control clockwise.

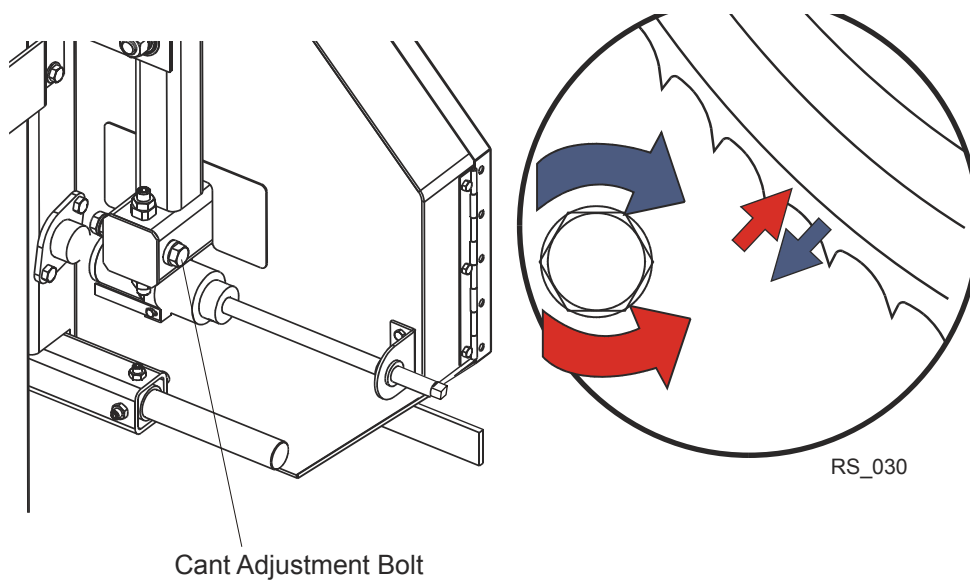

FIG. 4-7

9. Check the position of the blade on the drive-side blade wheel. The blade should be positioned on the wheel as described for the idle-side blade wheel. Adjust the drive-side blade wheel if necessary.

See Figure 4-8. Use the horizontal adjustment screws (marked with the blue and yellow arrows in the figure below) to adjust the drive-side blade wheel. Before adjusting the wheel, loosen the drive belt using the adjustment bolts marked with the orange arrows in the figure.

To move the blade back on the wheel, loosen the right adjustment screw one quarter turn. Loosen the jam nut on the left adjustment screw and tighten the screw. Tighten the left and right jam nuts.

To move the blade out on the wheel, loosen the left adjustment screw one quarter turn. Loosen the jam nut on the right adjustment screw and tighten the screw. Tighten the left and right jam nuts. When the adjustment is complete, tension the drive belt properly ([See Section 3.8](#)).

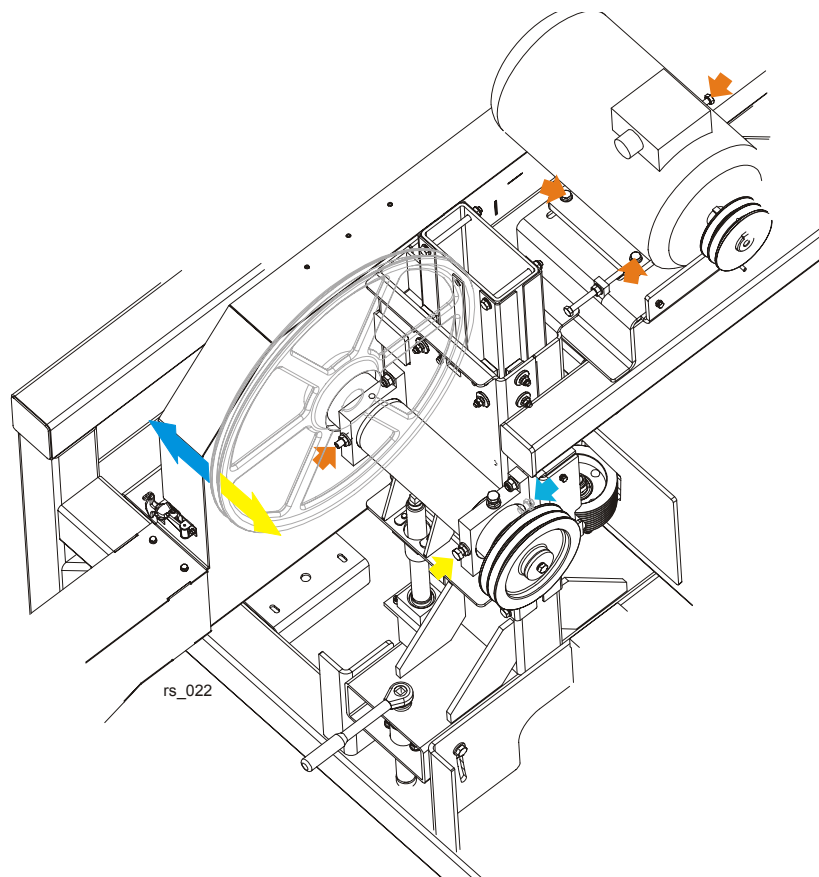

FIG. 4-8

4.4 Saw Head Adjustment

See Figure 4-9. The saw head should be set perpendicular to the vertical mast. Using the two sets of adjustment screws in the mast slide pads, you can adjust the saw head in relation to the mast. To raise or lower the outside of the saw head, loosen the locking nuts on either of the sets of screws. Then turn the adjustment nuts clockwise to raise the outside of the saw head or counterclockwise to lower the outside of the saw head. **NOTE:** Be sure to adjust the nuts evenly so the slide pad is parallel to the mast tube. If further adjustment is needed and one set of the nuts has been fully adjusted, use the other.

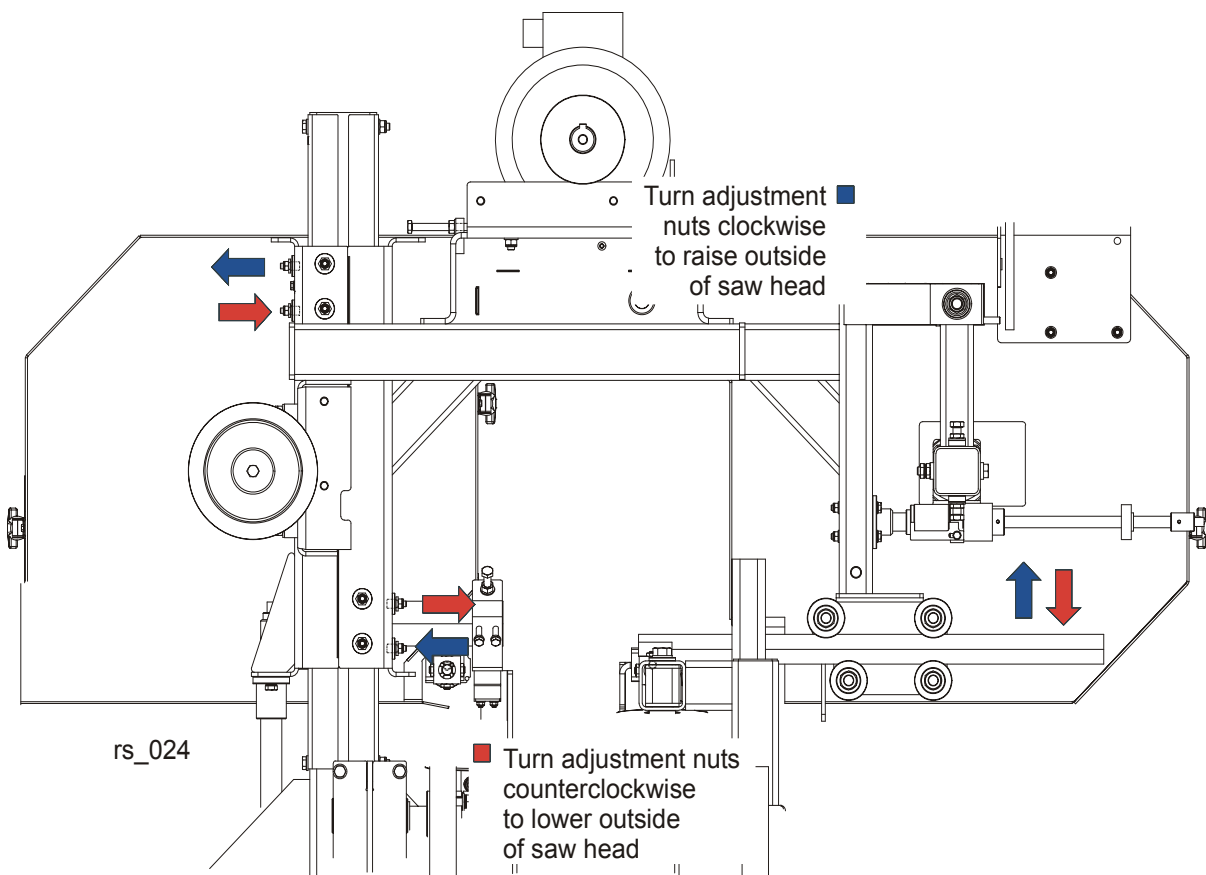

FIG. 4-9

4.5 Blade Guide Arm Vertical Adjustment

1. Adjust the blade guide arm out to within 1/2" (15 mm) of full open.
2. Measure the distance from the top surface of the feed track to the arm.

See Figure 4-10.

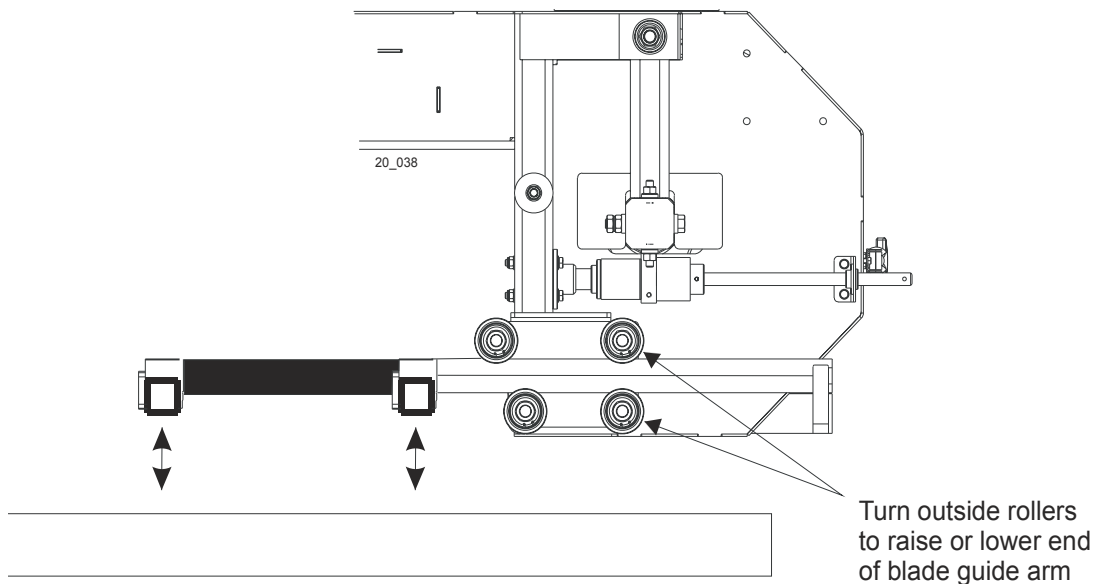

FIG. 4-10

3. Adjust the blade guide arm in to within 1/2" (15 mm) of full closed. Measure again the distance between the arm and the feed track.
4. Adjust the arm so that the measurement from the top of the track feed to the arm in the closed position is the same as the measurement from the top of the track feed to the arm in the open position.

If the arm is too low in the closed position, loosen the lower outside roller and tighten the upper outside roller. (See Step 5.)

If the arm is too high in the closed position, loosen the upper outside roller and tighten the lower outside roller. (See Step 5.)

5. The rollers are mounted on cam bolts that raise or lower the arm when turned.

To adjust the rollers, locate the cam bolt inside the housing and turn until the arm is lowered or raised as needed. Recheck the arm in both the open and closed positions.

Repeat adjustments until the arm is the same distance from the track feed in the open and closed position.

6. The blade guide arm should be snug, but not too tight, in the rollers. You should be able to move it in and out with firm hand pressure. There should be no side-to-side play.

4.6 Blade Guide Arm Horizontal Adjustment

1. Put the blade guide assembly back in the arm (if you took it out). Put the assembly back so that the flanged collar on the roller is about 3.0 mm (0.04") from the back of the blade when the arm is 15 mm (0.6") from full open.
2. Close the throat to within 15 mm (0.6") from fully closed. Check to see that the flange is the same distance from the back of the blade.

See Figure 4-11.

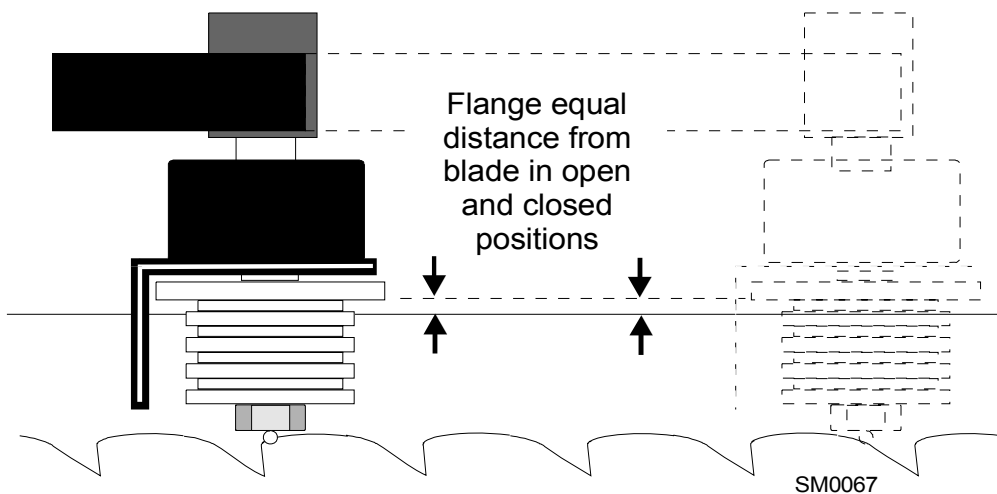

FIG. 4-11

3. If adjustment is needed, the guide rollers can be adjusted in or out on the threaded mounts to open or close the gap.

See Figure 4-12.

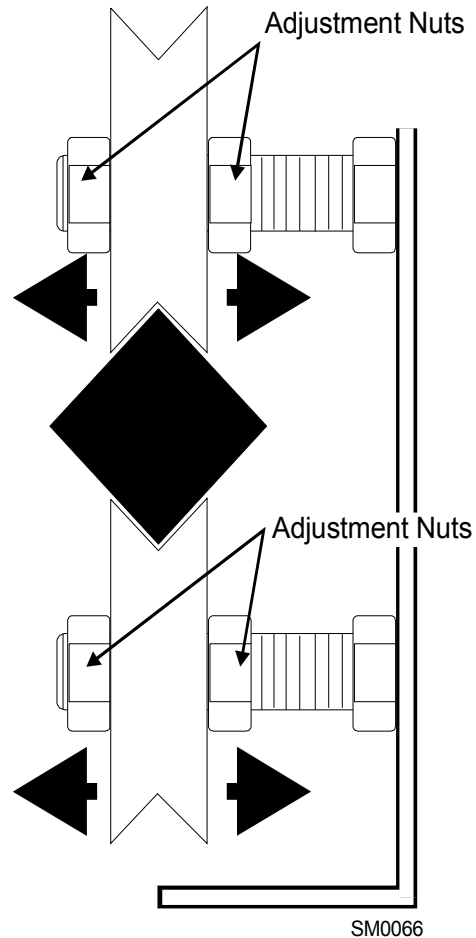

FIG. 4-12

4. Adjusting the outside two rollers inward will cause the flange to move away from the blade.
5. Adjusting the two outside rollers outward will cause the flange to move toward the blade.
6. Adjust until the roller flange is the same distance from the back of the blade in the open and closed position.

4.7 Aligning the Blade Guides

Each Wood-Mizer resaw has two blade guide assemblies that help the blade maintain a straight cut. The two blade guide assemblies are positioned on the cutting head to guide the blade on each side of the material being cut.

One blade guide assembly is mounted in a stationary position on the drive side of the cutting head. This assembly is referred to as the "inner" blade guide assembly.

The other blade guide assembly is mounted on the idle side of the cutting head. It is referred to as the "outer" assembly and is adjustable for various widths of materials to be processed.

Blade guide alignment includes four steps:

- Blade Deflection,
- Blade Guide Vertical Tilt,
- Blade Guide Flange Spacing,
- Blade Guide Horizontal Tilt.

Perform the blade guide alignment after you have aligned the blade on the wheels. After blade guide alignment, check the scale indicator to make sure it is adjusted properly ([See Section 4.13](#)).

NOTE: During blade guide alignment, remove the blade guide adjusting screws and apply a lubricating oil such as 10W30 or Dexron III to each screw. This will prevent the screws and threaded holes from corroding and make screw adjustments easier.

4.8 Blade Deflection

Perform the following steps to achieve proper blade deflection with the blade guides.

1. Raise the carriage until the blade is 200 mm above the feed track. Measure the actual distance with a tape from the top of the track to the bottom of the blade.
2. Install the blade guides. Make sure the two set screws shown are threaded into the blade guide shaft until they touch each other.

See Figure 4-13.

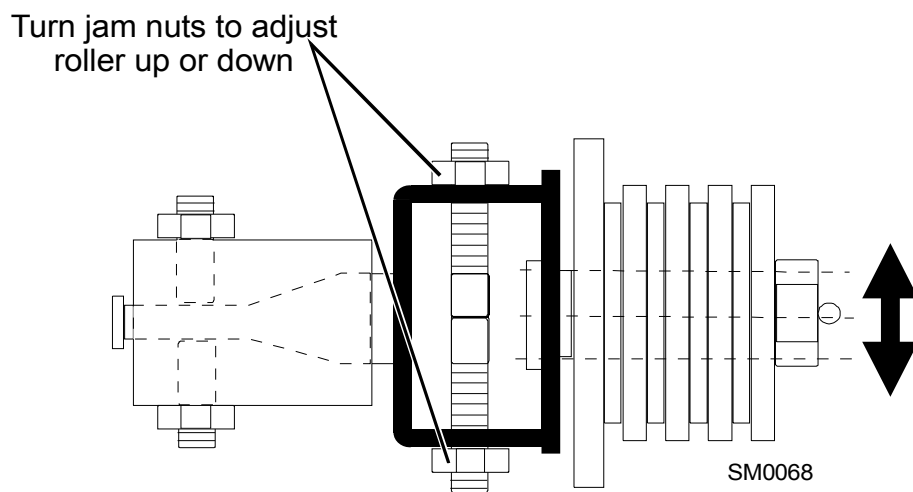

FIG. 4-13

3. Loosen the bottom jam nut and tighten the top jam nut until the blade guide deflects the blade down 6.0 mm (0.24").
4. Repeat for the other blade guide.

NOTE: Be sure that the blade guide touches the blade in both guide assemblies. The outer blade guide should be checked with the arm all the way in and all the way out.

4.9 Blade Guide Vertical Tilt Adjustment

Check that the blade guide does not tilt the blade up or down. A Blade Guide Alignment Tool (BGAT) is provided to help you measure the vertical tilt of the blade.

1. Open the blade guide arm 15 mm (0.6") from full open.
2. Clamp the alignment tool on the blade. Position the tool close to a blade guide roller. Be sure the tool does not rest on a tooth or burr, and is lying flat on the blade.

See Figure 4-14.

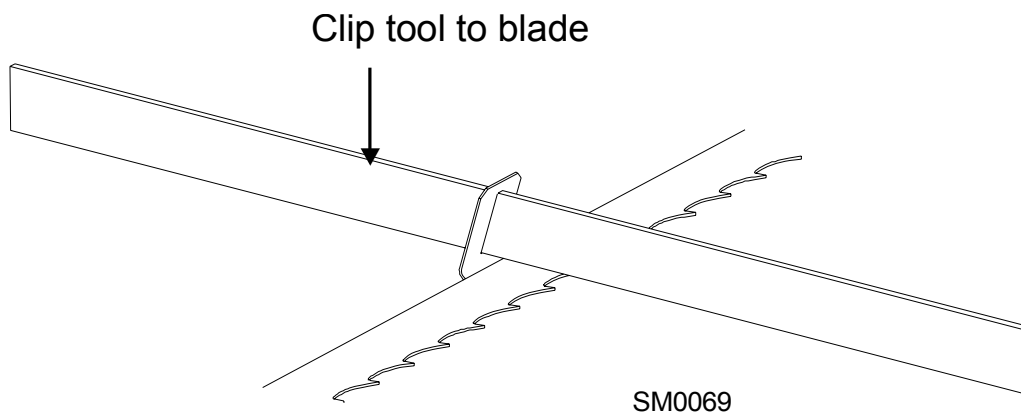

FIG. 4-14

3. Measure the distance from the bottom of the tool to the feed track chain at the center of the tool and then at the front end of the tool.
4. The two distances should be equal. If they differ, adjust the vertical tilt of the blade guide using the adjustment screws shown in the figure below.

See Figure 4-15. Loosen the jam nuts on the top and bottom vertical tilt adjustment screws. To tilt the roller up, loosen the bottom screw and tighten the top screw. To tilt the roller down, loosen the top screw and tighten the bottom screw. Tighten the jam nuts and

recheck the tilt of the blade.

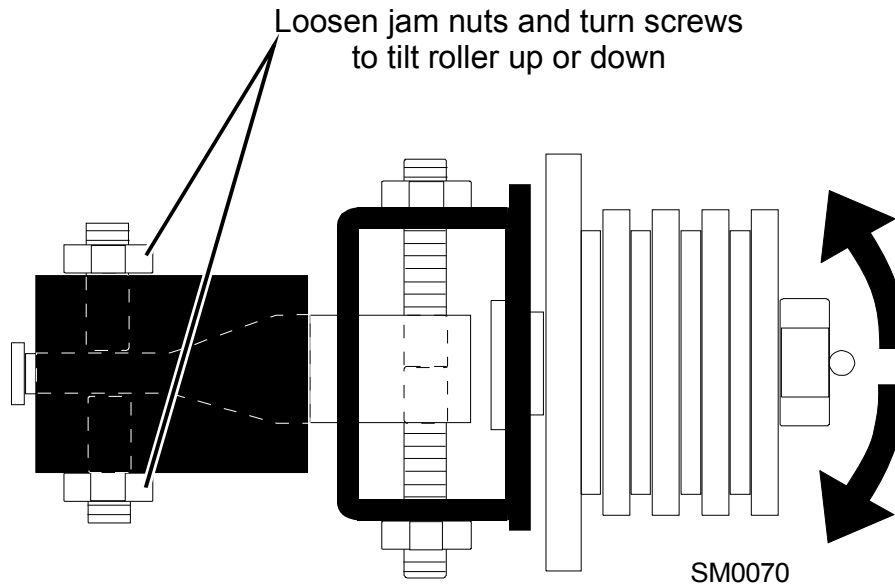

FIG. 4-15

5. Measure the distance from the bottom of the tool to the top of the feed track chain at the rear end of the tool. If the measurement does not equal the other two measurements taken, readjust the vertical tilt of the blade guide.
6. Move the blade guide alignment tool close to the other blade guide and repeat the above steps. Adjust the vertical tilt of this guide if necessary.

NOTE: If major adjustments to blade guide tilt were made, measure the distance between the blade and the feed track chain again to ensure the correct 6.0 mm (0.24") blade guide deflection. Adjust if necessary.

4.10 Blade Guide Spacing

HINT: When adjusting blade guide spacing, loosen the top set screw and one side set screw only. This will ensure horizontal and vertical tilt adjustments are maintained when the set screws are retightened.

1. Adjust the inner blade guide so the blade guide flange is approximately 1.5 – 3.0 mm (0.06 - 0.12") from the back of the blade.
2. Loosen one side and one top set screw shown. Tap the blade guide forward or backward until properly positioned.

See Figure 4-16.

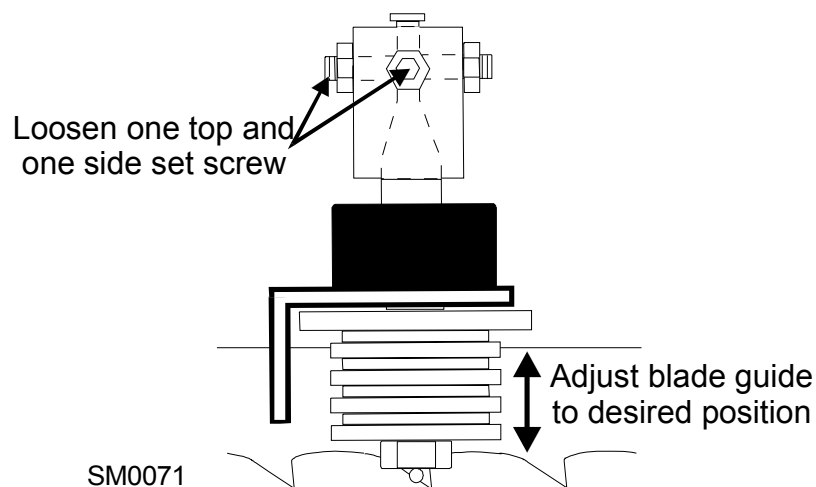

FIG. 4-16

3. Retighten the two set screws.
4. Adjust the outer blade guide in the same way so the blade guide flange is approximately 1.5 – 3.0 mm (0.06 - 0.12") from the back of the blade.

4.11 Blade Guide Horizontal Tilt Adjustment

1. Finally, both blade guides must be tilted horizontally. Adjust the blade guide arm halfway in.

See Figure 4-17.

FIG. 4-17

2. Place the Blade Guide Alignment Tool against the face of the outer blade guide roller.
3. Center the tool on the roller and measure between the back edge of the blade and the ruler at the end closest to the inner blade guide ("B").
4. Measure between the back edge of the blade and the other end of the ruler ("A").
5. The roller should be tilted slightly to the left ($A = B - 6.0 \text{ mm [0.24"]}$).
6. Use the side set screws to adjust the horizontal tilt of the roller.
7. Repeat steps 3-7 for the inner blade guide roller.

NOTE: Once the blade guides have been adjusted, any cutting variances are most likely caused by the blade. **See the Wood-Mizer® Blade Handbook, Form #600.**

4.12 Blade Height Scale Adjustment

After the entire resaw has been aligned and all adjustments made, check that the blade height scale indicates the true distance from the blade to the feed track chain.

1. Measure from the bottom edge on a down-set tooth of the blade to the top of the feed track chain.

See Figure 4-18.

2. View the blade height scale with eyes level with the indicator.

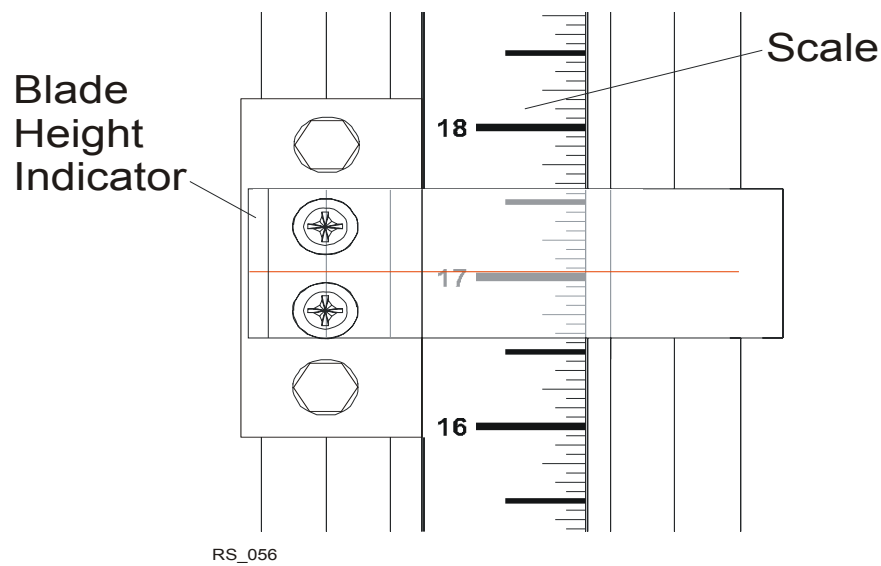

FIG. 4-18

3. Loosen the indicator bracket mounting bolts and adjust the bracket until the indicator is aligned with the correct mark on the scale. Retighten the bracket mounting bolts.

For example, if the measurement from blade to feed track chain was 100 mm, make sure the indicator reads 100 mm on the scale.

4.13 Infeed And Outfeed Tables

Check that the infeed and outfeed tables are level with the feed track chain. If not, adjust the height of the tables using the adjustment bolts shown in the figure below.

See Figure 4-19. To adjust the height of the table, loosen the locking nuts on the table

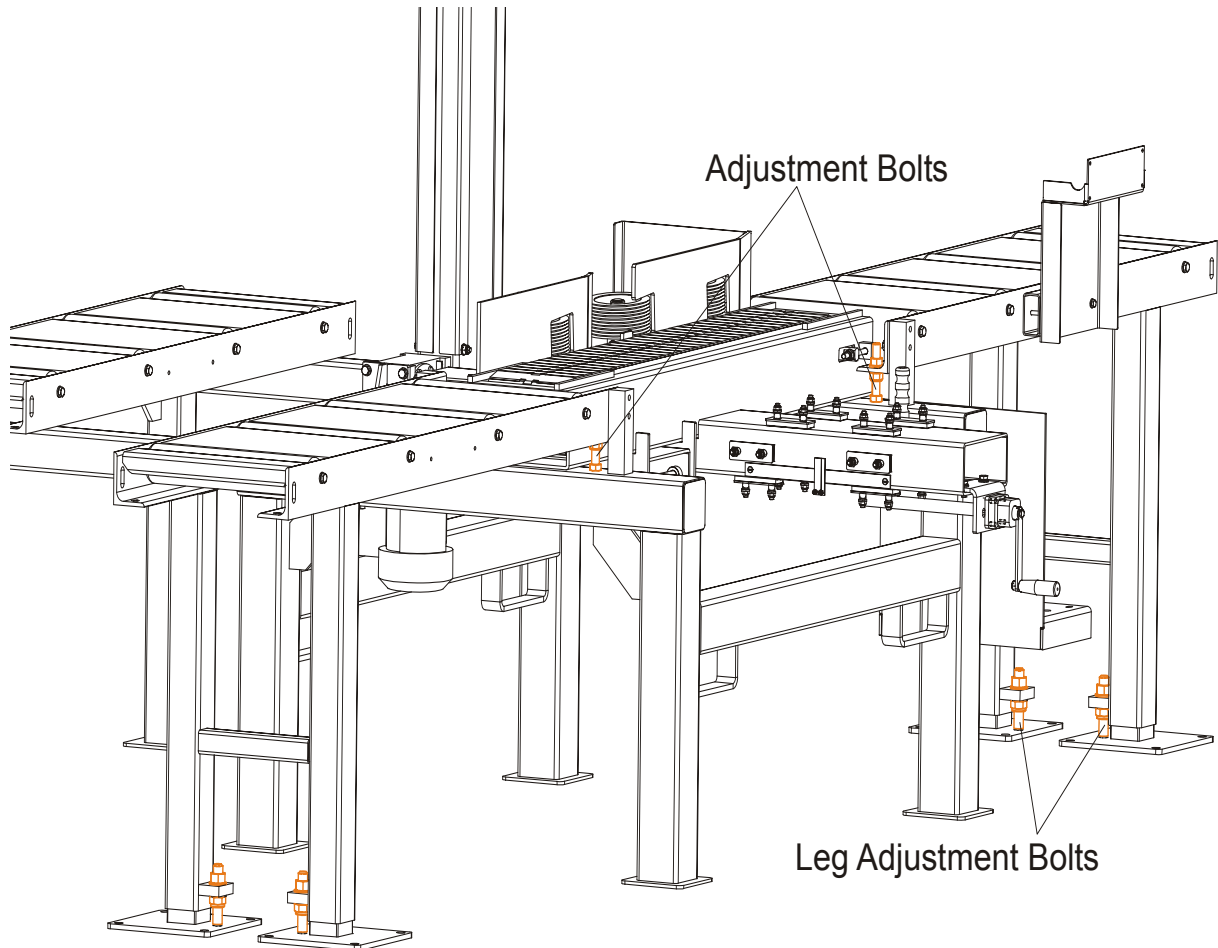

FIG. 4-19

adjustment bolts and turn appropriately the adjustment nuts.

SECTION 5 SPECIFICATIONS

5.1 Overall Dimensions

See Figure 5-1. The major dimensions of the resaw are shown below (all dimensions are in millimeters).

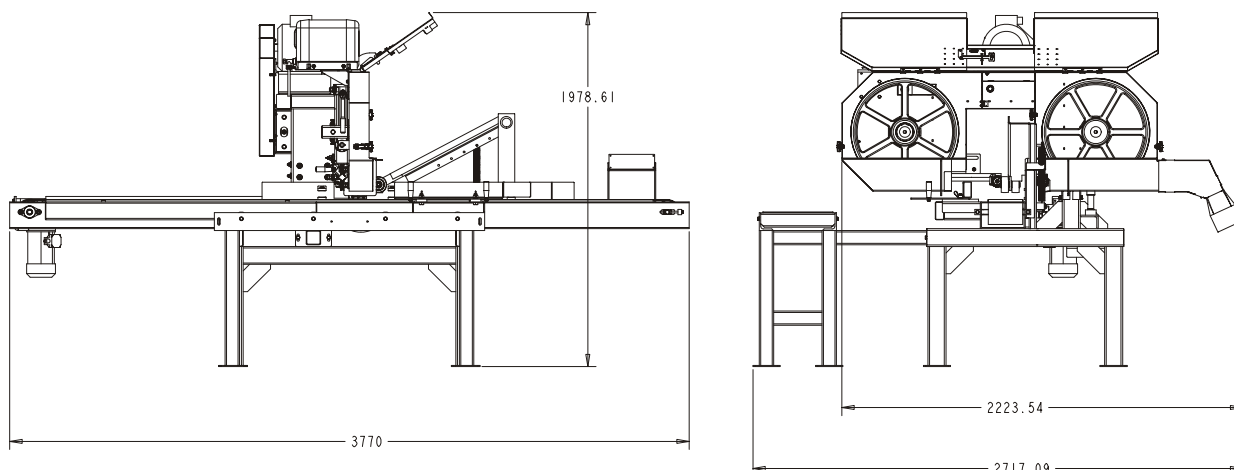

FIG. 5-1

See Table 5-1. The overall dimensions of the resaw are listed in the table below.

Weight	875 kg
Height	2110 mm
Width	2720 mm
Length	3770 mm

TABLE 5-1

See Figure 5-2. The figure shows the locations of resaw legs.

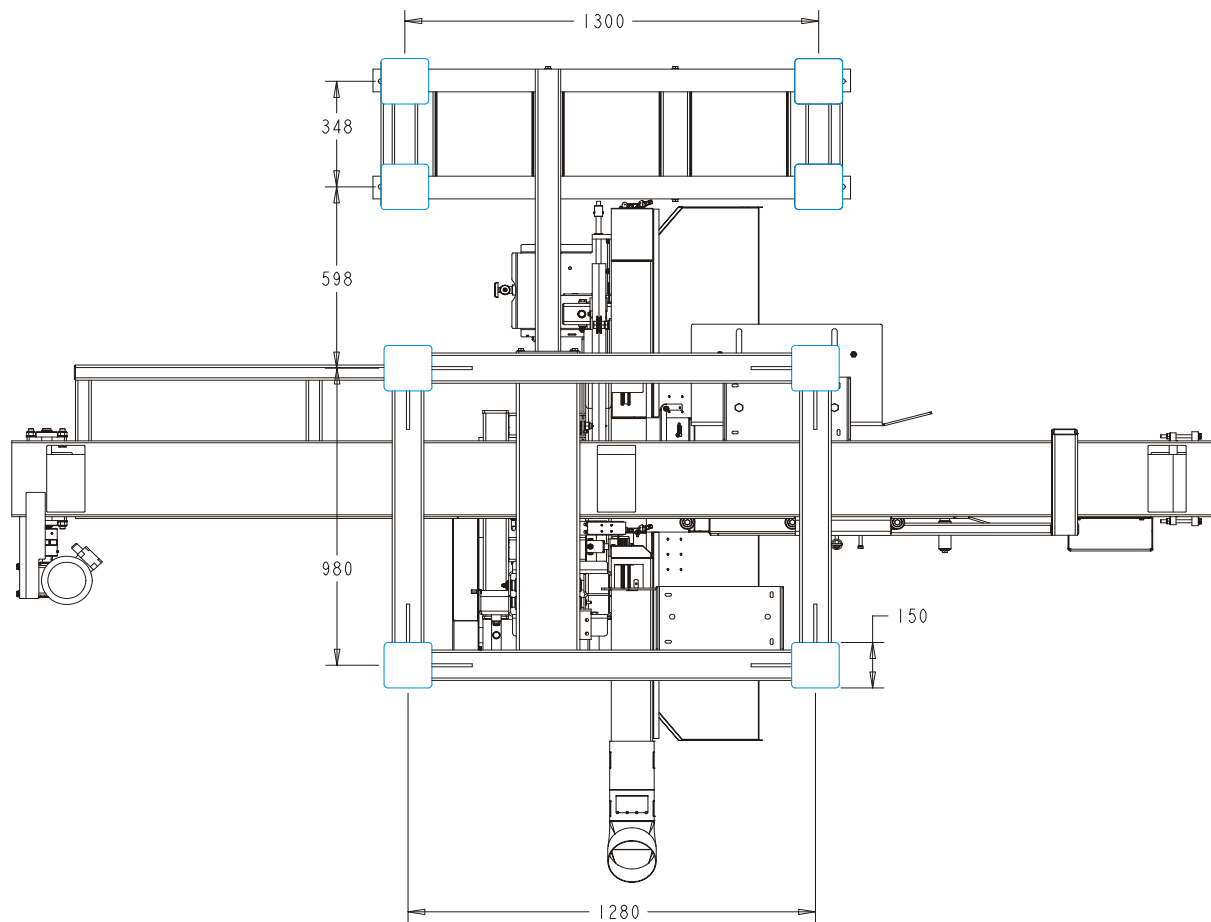

FIG. 5-2

5.2 Cutting Capacity

See Table 5-2. The material size and performance capacities of the resaw are given below.

Cutting Length	0.9 - 2.5 m
Material Height	10-400 mm
Material Width	75-300 mm
Feed Speed	0-30 m/min
Minimum Cutting Height	4 mm
Maximum Cutting Height	200 mm

TABLE 5-2

See Table 5-3. Wood-Mizer TRU•SHARP™ offers three types of blades to provide efficient sawing. The type of wood you saw should determine which blade you choose for optimum performance.

Motor Size	Recommended Blade Type		
	Softwood	Medium Hardwood	Frozen Timber or Dense Hardwood
5 HP - 15 HP	.042 x 7/8 x 1 1/4"	.042 x 7/8 x 1 1/4 "	.045 x 7/8 x 1 1/4" F1

5.3 Blade Motor Specifications

See Table 5-4. See the table below for blade motor specifications for your resaw model.

Motor Type	Manufacturer	Model	Power	Other Specifications
E11 Electric	Tamel SA, Poland	Sg 132M-4B HM	7,5kW	400 V/50Hz; 15 Amp; 1450 r.p.m.
E15 Electric	Tamel SA, Poland	Pssg 132M-4A	11kW	400 V/50Hz; 23 Amp; 1450 r.p.m.

TABLE 5-4

See Table 5-5. The noise levels of the Wood-Mizer resaw are listed below.

	Idle	Engaged
Resaw Equipped With Electric Motor	81,1 dB (A)	95,3 dB (A)

TABLE 5-5

5.4 Electrical Diagram, CE version

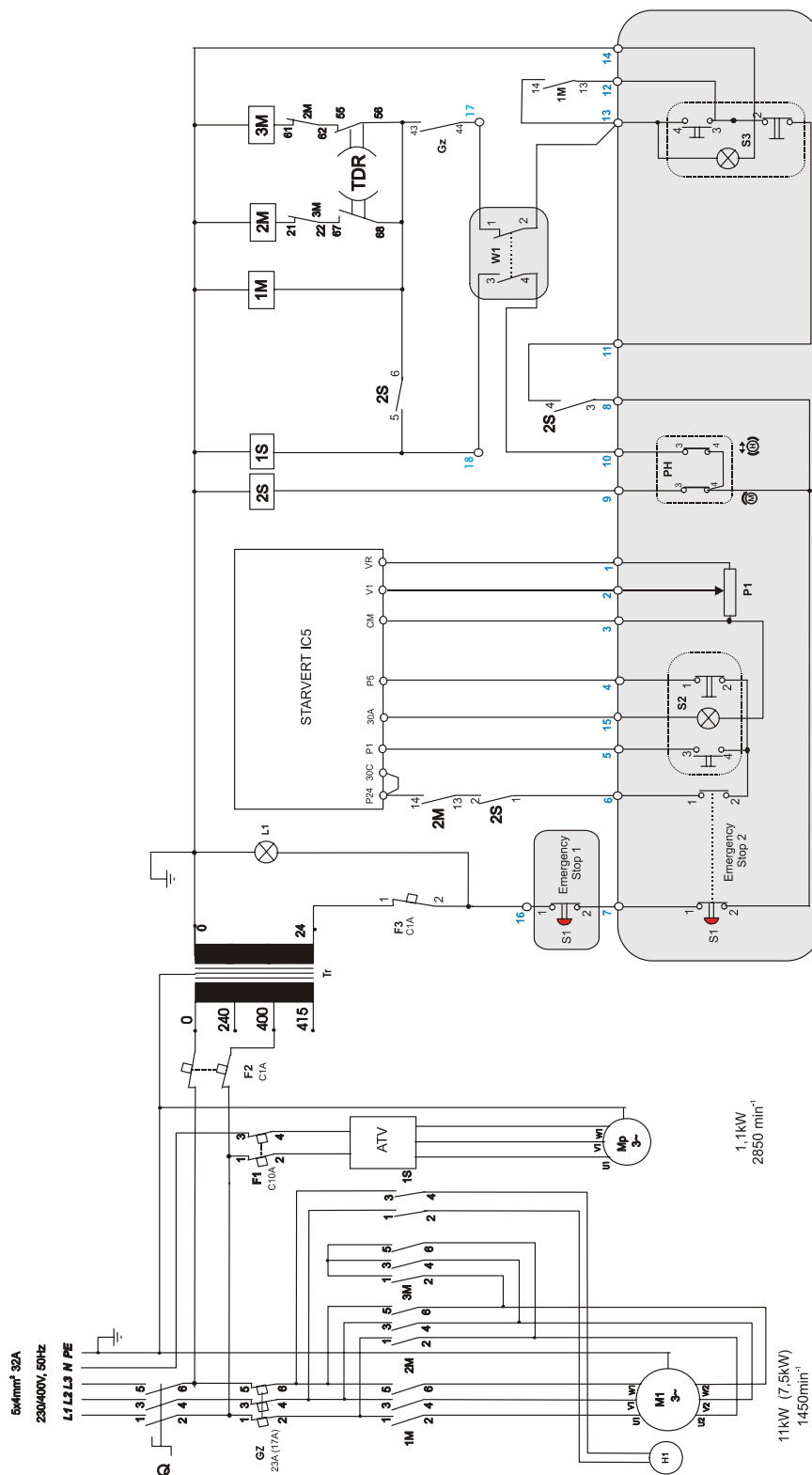

FIG. 5-2

5.5 Electrical Diagram, African version

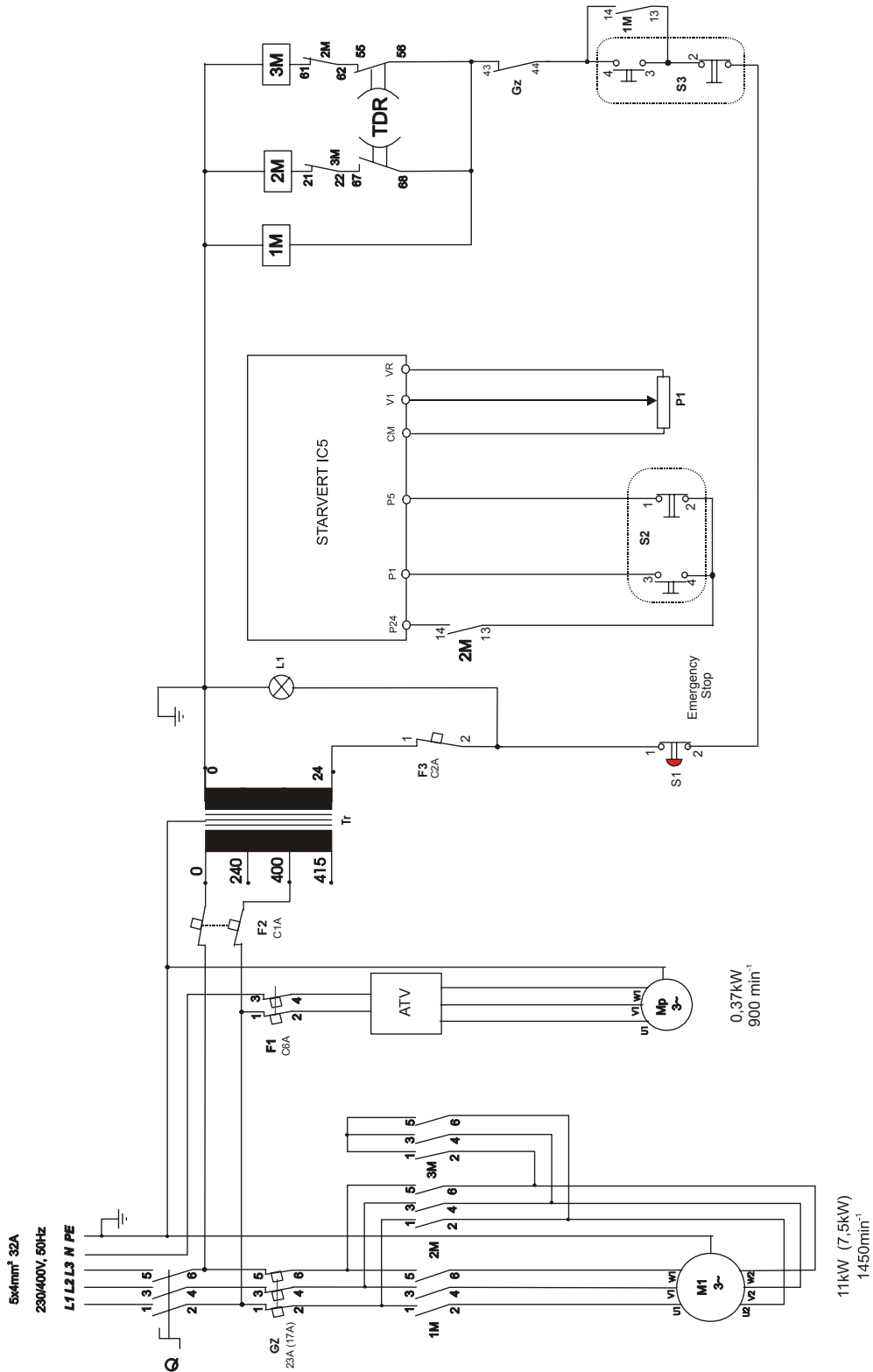

FIG. 5-2

5.6 Electrical Component Layout Diagram

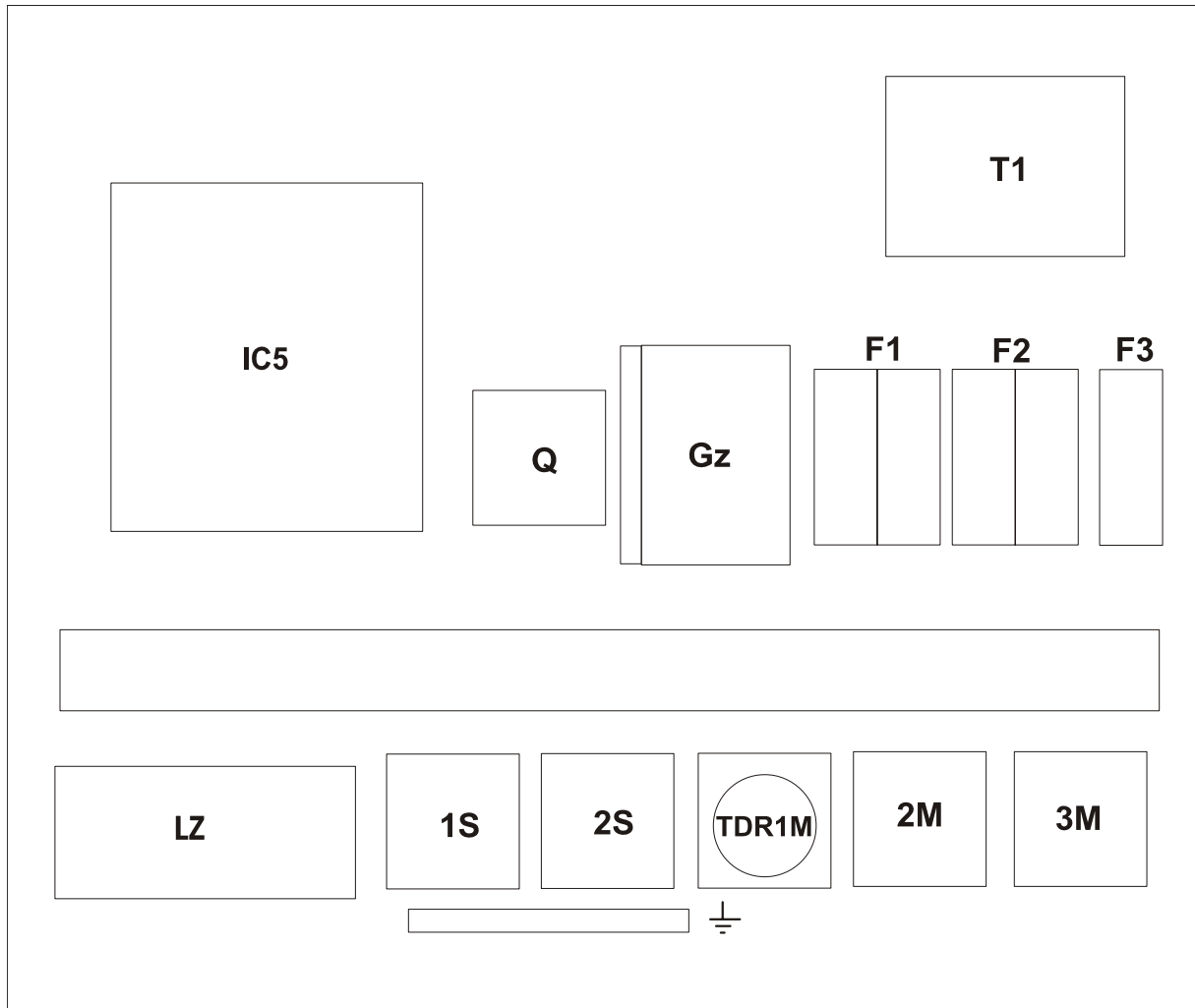

FIG. 5-2

5.7 Electrical Component List, SHR-F

Symbol	Wood-Mizer Part No.	Description	Manufacturer
Tr	094487	Transformer, TMM/63/A 240/400/440/24	BREVE
Q	088265	Switch, ABB OT32E3	ABB
GZ	084330	Motor Switch, GZ1 M21	SCHNEIDER ELECTRIC
F1	093904	Circuit Breaker, C60N 2P C16 24337	SCHNEIDER ELECTRIC
F2	093905	Circuit Breaker, C60N 2P C1 24331	SCHNEIDER ELECTRIC
F3	088278 084454	Circuit Breaker, C60N 1P C2 24396 - E11 Circuit Breaker, C60N 1P C2 24396 - E15	SCHNEIDER ELECTRIC
1M, 2M	084306	Contactor, LC1 D18	SCHNEIDER ELECTRIC
3M	084305	Contactor, LC1 D09	SCHNEIDER ELECTRIC
1S, 2S	084309	Contactor, LC1K0601	SCHNEIDER ELECTRIC
TDR	084037	Time Relay, LAD S2	SCHNEIDER ELECTRIC
S1	086556	Emergency Stop Button, XB4BS542	MOELLER
S2,S3	090452	START-STOP Switch, M22	MOELLER
P1	093749	Potentiometer, M22 R1K (229489)	MOELLER
L1	090448	Control Light, M22 White	MOELLER
M1 (H1)	094996 093219 095003 094994	Motor, Sg132M-4B HM (motor brake) - E11 (CE) Motor, Sg132M-4PC HM (motor brake) - E15 (CE) Motor, Sg132M-4B - E11 (RSA) Motor, Sg132M-4PC - E15 (RSA)	INDUKTA
M2	090104	Track Feed Motor, SKh80X-4C1	BESEL
W1 ¹	094232 087650	Safety Switch, AZ17-11ZRK - E11 Safety Switch, GKMC03W2 - E15	SCHMERSAL HONEYWELL
IC5	096225	Speed Controller, LG STARVERT SV004 IC5-1F	LG
PH ²	091361 091362	Key Switch, M22 3-Position Contact, M22-K10 (2)	MOELLER

¹ used in CE version only

² used in CE version only

5.8 V-Belt Sizes

See Table 5-6. Belt sizes for the resaw are shown.

Belt Description	Belt Size	Wood-Mizer Part No.
Drive Belt (E11)	B72	095079
Drive Belt (E15)	2BX70	P04857-2
Blade Wheel Belt	B72.5	017922

TABLE 5-6

5.9 Dust Extractor Specifications

See Table 5-7. Specifications of the dust extractors used on the resaw are listed below.

Airflow	1200 m ³ /h
Inlet diameter	150 mm
Motor power	1,5 kW
Number of sacks	1 pcs
Sack capacity	0.25 mp
Weight	110 kg
Recommended conveying air velocity in the duct	20 m/s

TABLE 5-7

SECTION 6 REPLACEMENT PARTS

6.1 How To Use The Parts List

- Go to the appropriate section and locate the part in the illustration.
- Use the number pointing to the part to locate the correct part number and description in the table.
- Parts shown indented under another part are included with that part.
- Parts marked with a diamond (◆) are only available in the assembly listed above the part.

See the sample table below. Sample Part #A01111 includes part F02222-2 and subassembly A03333. Subassembly A03333 includes part S04444-4 and subassembly K05555. The diamond (◆) indicates that S04444-4 is not available except in subassembly A03333. Subassembly K05555 includes parts M06666 and F07777-77. The diamond (◆) indicates M06666 is not available except in subassembly K05555.

6.2 Sample Assembly				
REF	DESCRIPTION (◆ Indicates Parts Available In Assemblies Only)	PART #	QTY.	
	Sample Assembly, Complete (Includes All Indented Parts Below)	A01111	1	
1	Sample Part	F02222-22	1	
2	Sample Subassembly (Includes All Indented Parts Below)	A03333	1	
	Sample Part (◆ Indicates Part Is Only Available With A03333)	S04444-4	1	◆
3	Sample Subassembly (Includes All Indented Parts Below)	K05555	1	
	Sample Part (◆ Indicates Part Is Only Available With K05555)	M06666	2	◆
4	Sample Part	F07777-77	1	

To Order Parts:

From Europe call our European Headquarters and Manufacturing Facility in Kolo, Poland at **+48-63-2626000** or **+48-3912-1319**. From the continental U.S., call our toll-free Parts hotline **1-800-448-7881**. Have your customer number, vehicle identification number, and part numbers ready when you call. From other international locations, contact the Wood-Mizer distributor in your area for parts.

6 Replacement Parts

Blade Guide Assembly, Idle Side

6.2 Blade Guide Assembly, Idle Side

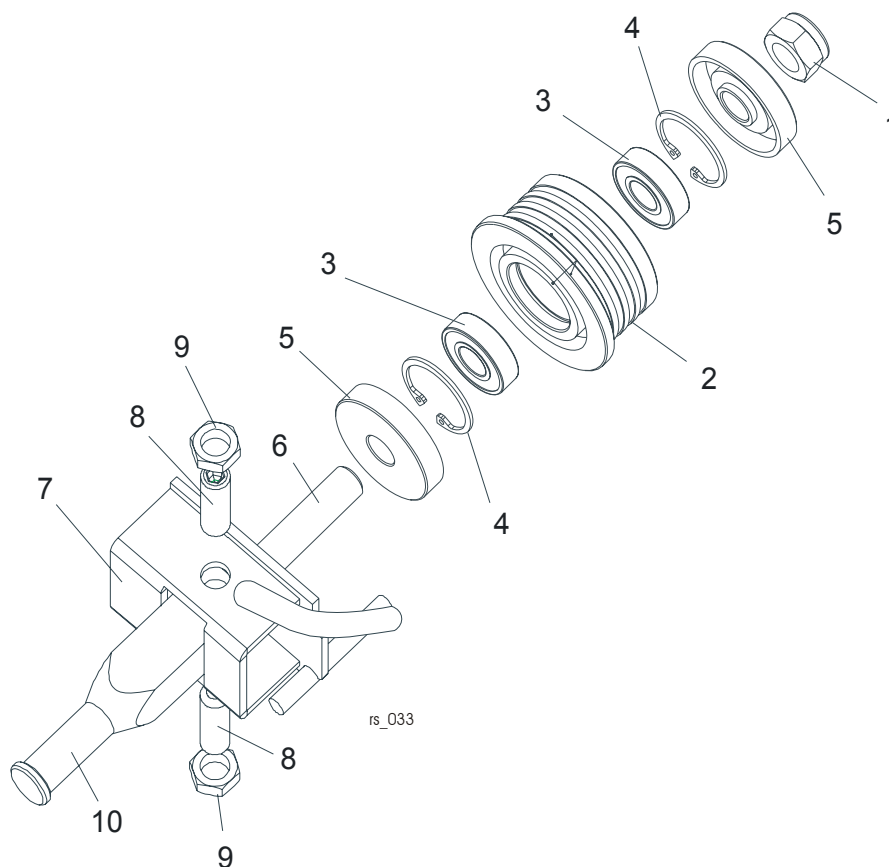

REF	DESCRIPTION (◆ Indicates Parts Available In Assemblies Only)	PART #	QTY.	
	BLADE GUIDE ASSEMBLY, IDLE SIDE	A08191	1	
	Roller Assembly, Standard Blade Guide	087887	1	
1	Nut, M12-8 Hex Nylon Zinc Lock	F81034-2	1	
2	Roller, Blade Guide Narrow	087889	1	◆
3	Bearing, 6001 2RSR NACHI	087893	2	
4	Ring, W28 Interior Retaining	F81090-9	2	
5	Washer, Zinc-Plated Spacer	087891-1	2	
6	Bolt, Blade Guide Roller Mounting Zinc-Plated	087763-1	1	
7	Bracket, Blade Guide Idle Side With Water Tube	W08495	1	
	Screw Kit, Blade Guide Adjustment w/Nuts (for two blade guide assemblies)	K09942	1	
8	Screw, 3/8-24 x 1 1/4" Socket Head Flat Point Stainless Steel Set	F05007-96	2	
9	Nut, 3/8-24 UNC Hex Zinc	F05010-22	2	
10	Shaft, Blade Guide Mount	S08196	1	

6.3 Blade Guide Assembly, Drive Side

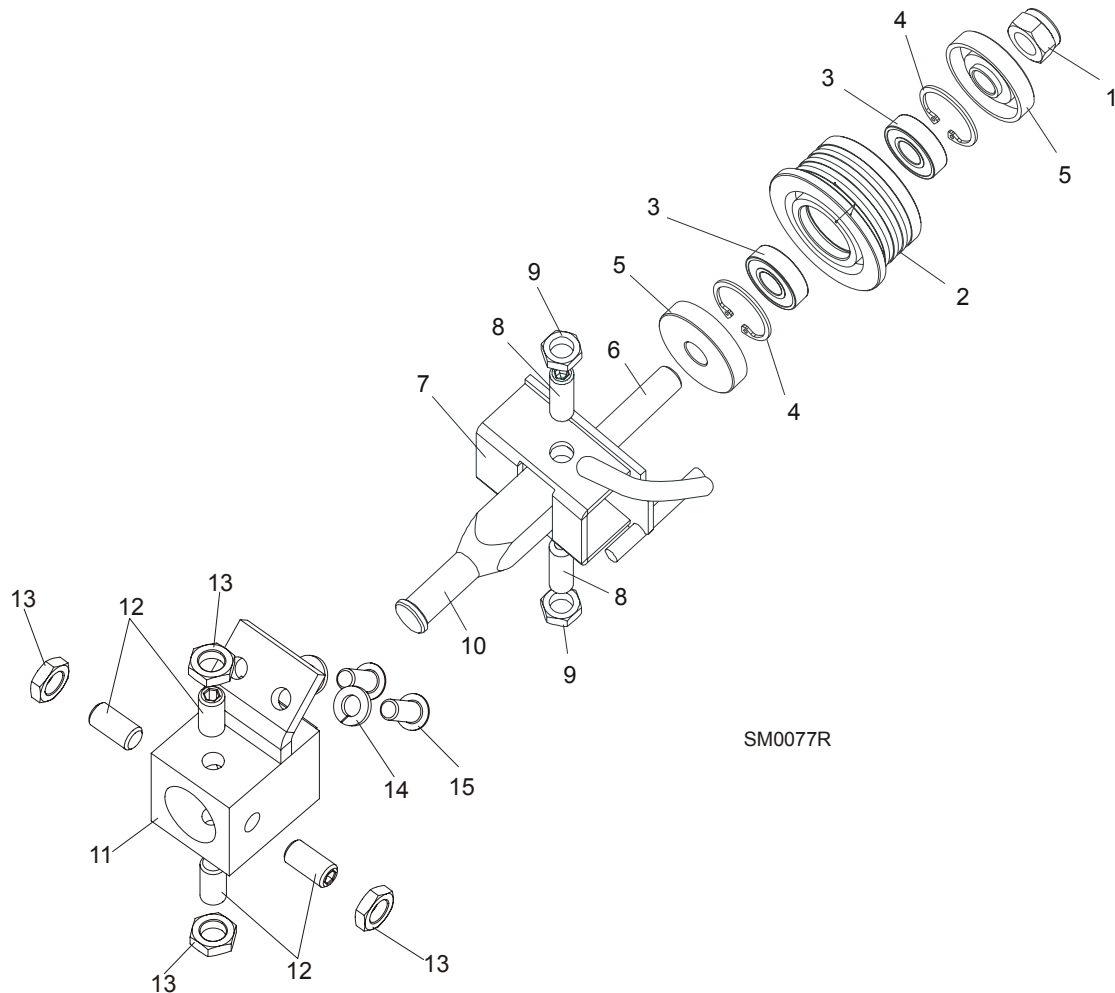

REF	DESCRIPTION (◆ Indicates Parts Available in Assemblies Only)	PART #	QTY.	
	BLADE GUIDE ASSEMBLY, DRIVE SIDE	A08197	1	
	Roller Assembly, Standard Blade Guide	087887	1	
1	Nut, M12-8 Hex Nylon Zinc Lock	F81034-2	1	
2	Roller, Blade Guide Narrow	087889	1	◆
3	Bearing, 6001 2RSR NACHI	087893	2	
4	Ring, W28 Inside Retaining	F81090-9	2	
5	Washer, Zinc-Plated Spacer	087891-1	2	
6	Bolt, Blade Guide Roller Mounting Zinc-Plated	087763-1	1	
7	Bracket Weldment, Blade Guide Painted	W08482	1	
	Screw Kit, Blade Guide Adjustment w/Nuts (for two blade guide assemblies)	K09942	1	
8	Screw, 3/8-24 x 1 1/4" Socket Head Flat Point Stainless Steel Set	F05007-96	2	
9	Nut, 3/8-24 UNC Hex Zinc	F05010-22	2	
10	Shaft, Blade Guide Mount	S08196	1	
11	BLOCK WELDMENT, BLADE GUIDE MOUNT PAINTED	088292-1	1	

6**Replacement Parts***Blade Guide Assembly, Drive Side*

12	SCREW, M10 X 1 X 20 DIN913 STAINLESS STEEL SET	F81015-1	4	
13	NUT, M10x1-04-ST-A2 ISO 8675 THIN	F81033-10	4	
14	WASHER, 8.2 SPLIT LOCK ZINC	F81054-4	2	
15	SCREW, 5/16-18X3/4 SOCKET BUTTON HEAD CAP BLACK OXIDE	F05006-7	2	

6.4 Blade Guide Arm Assembly

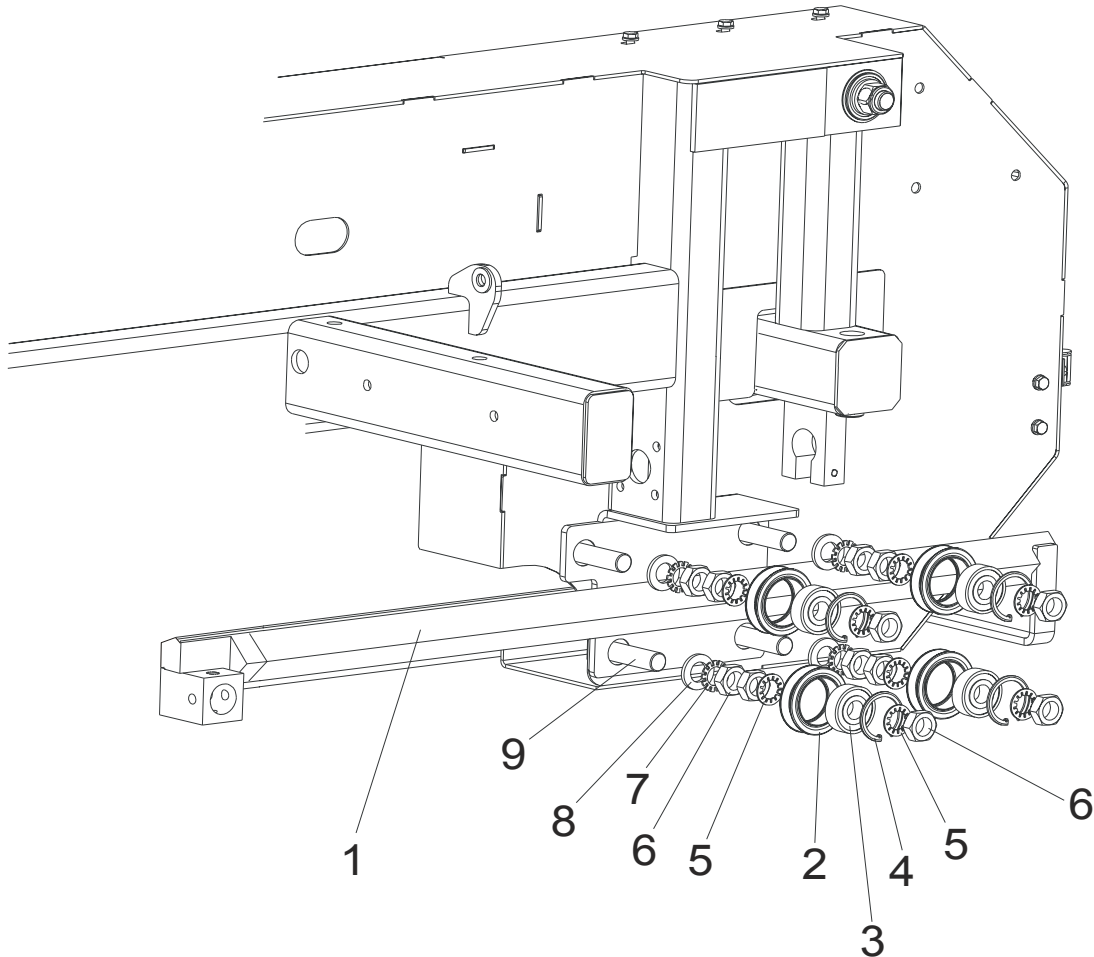

REF	DESCRIPTION (◆ Indicates Parts Available In Assemblies Only)	PART #	QTY.
1	ARM, RESAW BLADE GUIDE	093243-1	1
	ROLLER ASSEMBLY, V-GROOVE	A09059	4
2	Roller, V-Groove	S07989	4
3	Bearing, 6203-2 NSL 5/8	P06030-1	4
4	Ring, Retaining	F04254-8	4
5	WASHER, 5/8" INTERNAL STAR	F05011-25	8
6	NUT 5/8"-18 ZINC-PLATED	F05010-11	8
7	WASHER, 5/8" EXTERNAL STAR	F05011-26	4
8	WASHER, 17 FLAT ZINC	F81058-1	4
9	ROD, 5/8-18 THREADED	S12092	4

6

Replacement Parts Blade Wheel Assembly, Drive Side

6.5 Blade Wheel Assembly, Drive Side

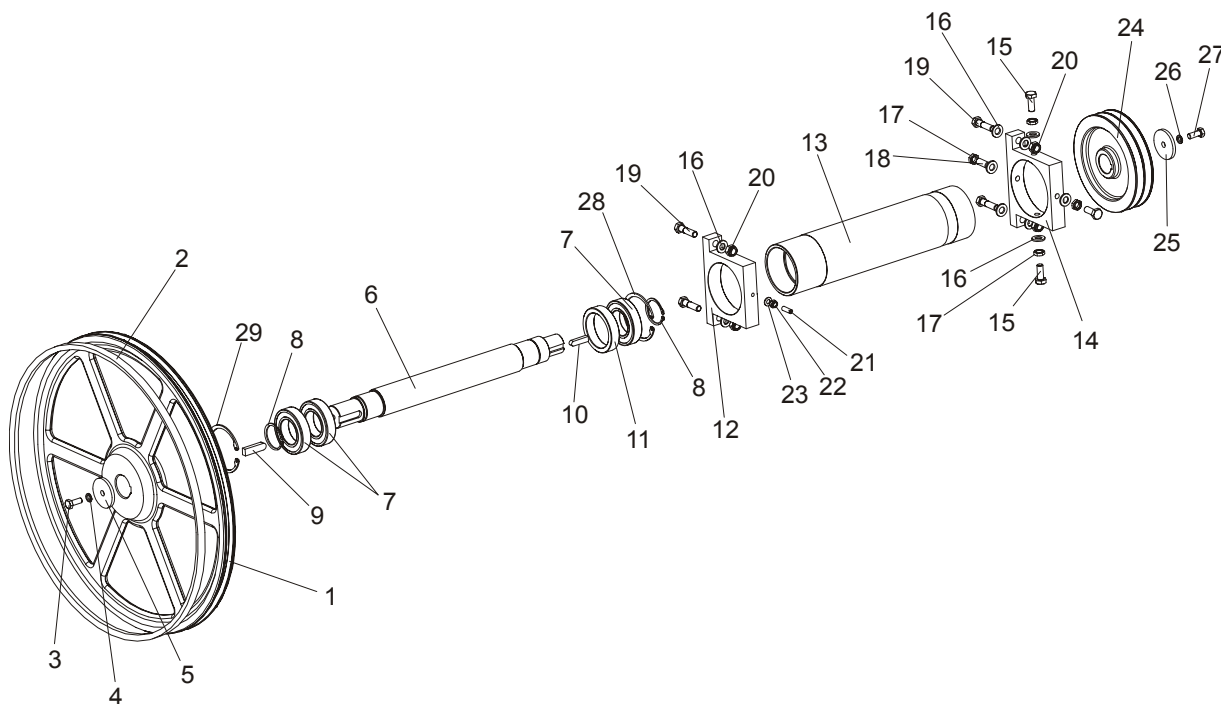

REF	DESCRIPTION (◆ Indicates Parts Available in Assemblies Only)	PART #	QTY.
1	WHEEL, BLADE DRIVE SIDE PAINTED	093218-1	1
2	V-BELT, B72.5	017922	1
3	BOLT, M10X25 8.8 HEX HEAD FULL THREAD	F81003-31	1
4	WASHER, 10.2 SPLIT LOCK ZINC	F81055-2	1
5	WASHER, BLADE WHEEL RETAINING ZINC-PLATED	088957-1	1
	SHAFT ASSEMBLY, RESAW DRIVE SIDE BLADE WHEEL	093239	1
6	Shaft, Resaw Drive Side Blade Wheel	093238	1
7	Bearing, 6210 2RSR FAG	093237	3
8	Ring, Z50 Outside Retaining	F81090-28	2
9	Key, AB 14x9x50 Parallel	093266	1
10	Key, AB 10x8x40 Parallel	091990	1
11	Bushing, Main Shaft Spacer	094439	1
12	Bracket, Drive Shaft Bushing Mount Zinc-Plated	093255-1	1
13	Bushing, Drive Shaft Housing Painted	093234-1	1
14	Bracket, Drive Shaft Adjustment Zinc-Plated	094535-1	1
15	Bolt, M12x1,25x30 DIN933 A2-70 Stainless Steel	F81004-44	3
16	Washer, 13 Flat Zinc	F81056-1	10
17	Nut, M12x1,25 DIN439 Thin Stainless Steel	F81034-9	3
18	Screw, M12x1,25x30 DIN913 Set Stainless Steel	F81016-1	1
19	Bolt, M12x45-8.8 Hex Head Zinc	F81004-32	4
20	Nut, M12-8 Hex Nylon Zinc Lock	F81034-2	4
21	Screw, M8x25 A2-70 DIN 913 Set Stainless Steel	F81014-3	1

Replacement Parts

Blade Wheel Assembly, Drive Side

6

22	Nut, M8-8-B Hex Nylon Zinc Lock	F81032-2	1	
23	WASHER, 8.4 FLAT ZINC	F81054-1	1	
24	PULLEY, SPB 224x1 2012/38 (E11) W/BUSHING	095078	1	
	PULLEY, RESAW (E15) 2-GROOVE	093254	1	
25	WASHER, BLADE WHEEL RETAINING ZINC-PLATED	088957	1	
26	WASHER, 10.2 SPLIT LOCK ZINC	F81055-2	1	
27	BOLT, M10X25 8.8 HEX HEAD FULL THREAD	F81003-31	1	
28	RING, Z50 OUTSIDE RETAINING	F81090-28	1	
29	RING, W90 INSIDE RETAINING	F81090-29	1	

6

Replacement Parts Idle Side Blade Wheel Assembly

6.6 Idle Side Blade Wheel Assembly

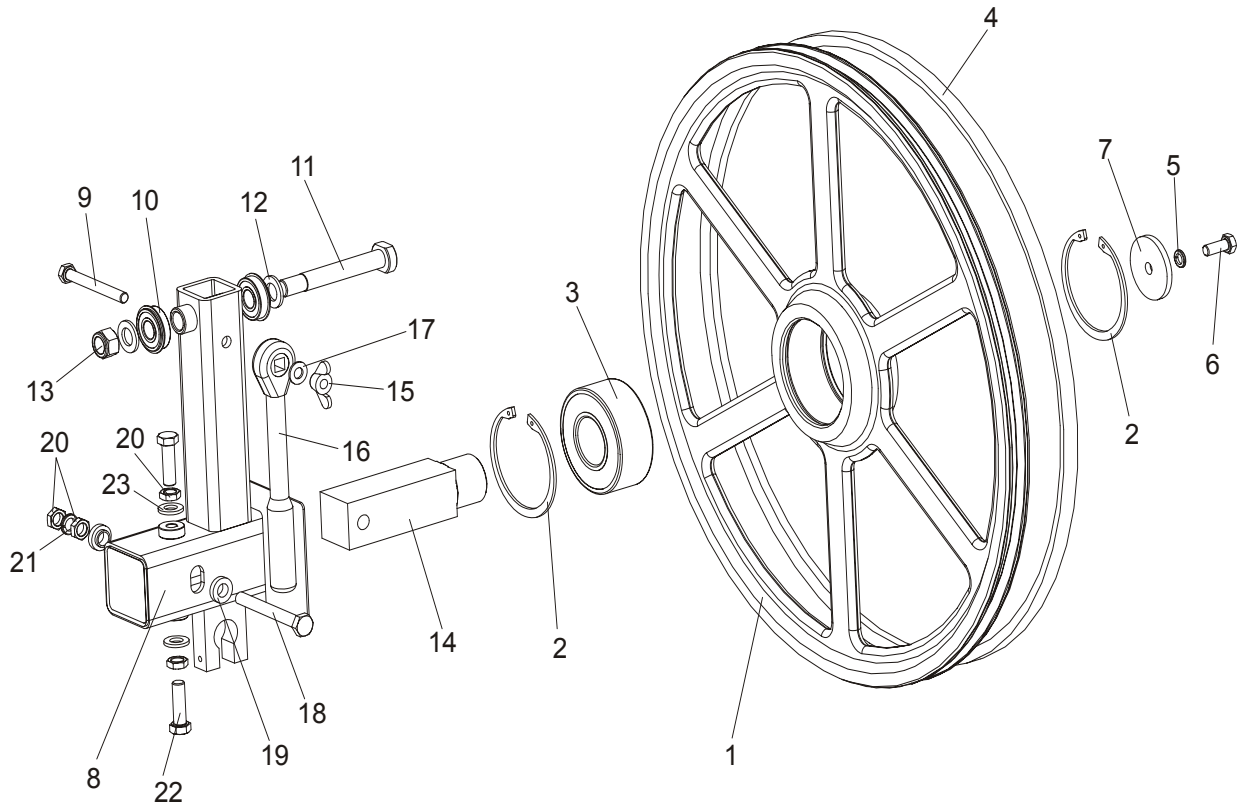

REF	DESCRIPTION (◆ Indicates Parts Available in Assemblies Only)	PART #	QTY.
	WHEEL ASSEMBLY, IDLE SIDE BLADE	088764	1
1	Wheel, Idle Side Blade	088419-1	1
2	Ring, W100 Inside Retaining	F81090-10	2
3	Bearing, 3309B.2RSR.TVH FAG	086428	1
4	V-BELT, B72.5	017922	1
5	WASHER, 10.2 SPLIT LOCK ZINC	F81055-2	1
6	BOLT, M10X25 8.8 HEX HEAD FULL THREAD	F81003-31	1
7	WASHER, BLADE WHEEL RETAINING ZINC-PLATED	088957-1	1
8	ARM WELDMENT, RESAW IDLE SIDE BLADE WHEEL	094539-1	1
9	Bolt, M10x90-8.8-B Hex Head Zinc	F81003-66	1
10	BEARING, 6203-2RS NR NSK W/SNAP RING	086395	2
11	BOLT, ARM BEARING MOUNT	086404	1
12	WASHER, 17 FLAT ZINC	F81058-1	2
13	NUT, M16-8 HEX NYLON ZINC LOCK	F81036-2	1
14	SHAFT, IDLE SIDE BLADE WHEEL	088474	1
15	NUT, M10 WING ZINC	F81033-8	1
16	SPANNER, BLADE TENSION ADJUSTMENT	091620	1
17	WASHER, 10.5 FLAT ZINC	F81055-1	1
18	BOLT, M12X1.25X100-8.8 HEX HEAD FULL THREAD ZINC	F81004-41	1

Replacement Parts
Idle Side Blade Wheel Assembly

6

19	WASHER, FLANGED ZINC-PLATED	086769-1	2	
20	NUT, M12X1.25 8.8 HEX THIN ZINC	F81034-5	4	
21	WASHER, Z12.2 SPLIT LOCK ZINC	F81056-2	1	
22	BOLT, M12X1.25X40-8.8 HEX HEAD FULL THREAD ZINC	F81004-42	1	
23	WASHER, 13 FLAT ZINC	F81056-1	2	

6

Replacement Parts Blade Tensioner Assembly

6.7 Blade Tensioner Assembly

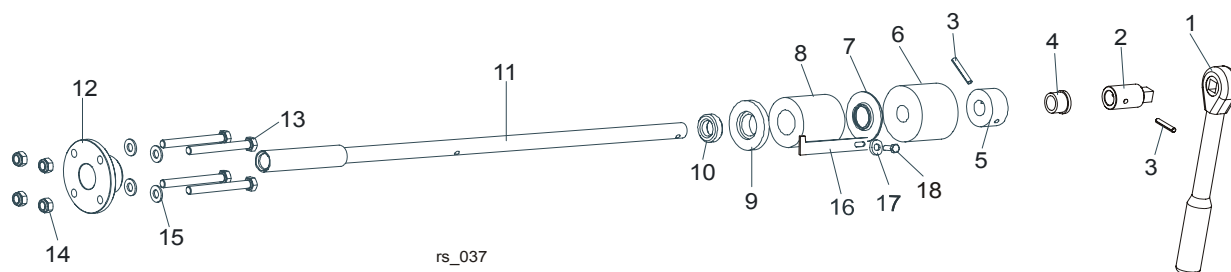

REF	DESCRIPTION (◆ Indicates Parts Available In Assemblies Only)	PART #	QTY.	
	BLADE TENSIONER - COMPLETE	090587	1	
1	Spanner, Blade Tension Adjustment	091620	1	
2	End, Blade Tensioner Shaft Zinc-Plated	091606-1	1	
3	Pin, 5 x 30 Roll Zinc	F81044-21	2	
4	Bushing, 5/8 I.D. Bronze	P05135	1	
5	Collar, Blade Tensioner Retaining	086712-1	1	
6	Bushing, Rubber Stop	P12165	1	
7	Guide, Tension Handle	014925	1	
8	Spring, Blade Tensioner	014828	1	
9	Housing, Thrust Bearing	086674-1	1	
10	Bearing, 51103 FLT Thrust Ball	086675	1	
11	Shaft, Blade Tensioner Zinc-Plated	086669-1	1	
12	Nut, Blade Tensioner	086672-1	1	
13	Bolt, M8x70 8.8 Hex Head Zinc	F81002-71	4	
14	Nut, M8-8-B Hex Nylon Zinc Lock	F81032-2	4	
15	Washer, 8.4 Flat Zinc	F81054-1	8	
16	Indicator, Blade Tension Zinc-Plated	092467-1	1	
17	Washer, 6.4 Flat Zinc	F81053-1	1	
18	Bolt, M6x16 8.8 Hex Head Full Thread Zinc	F81001-15	1	

6.8 Middle Throat Screw

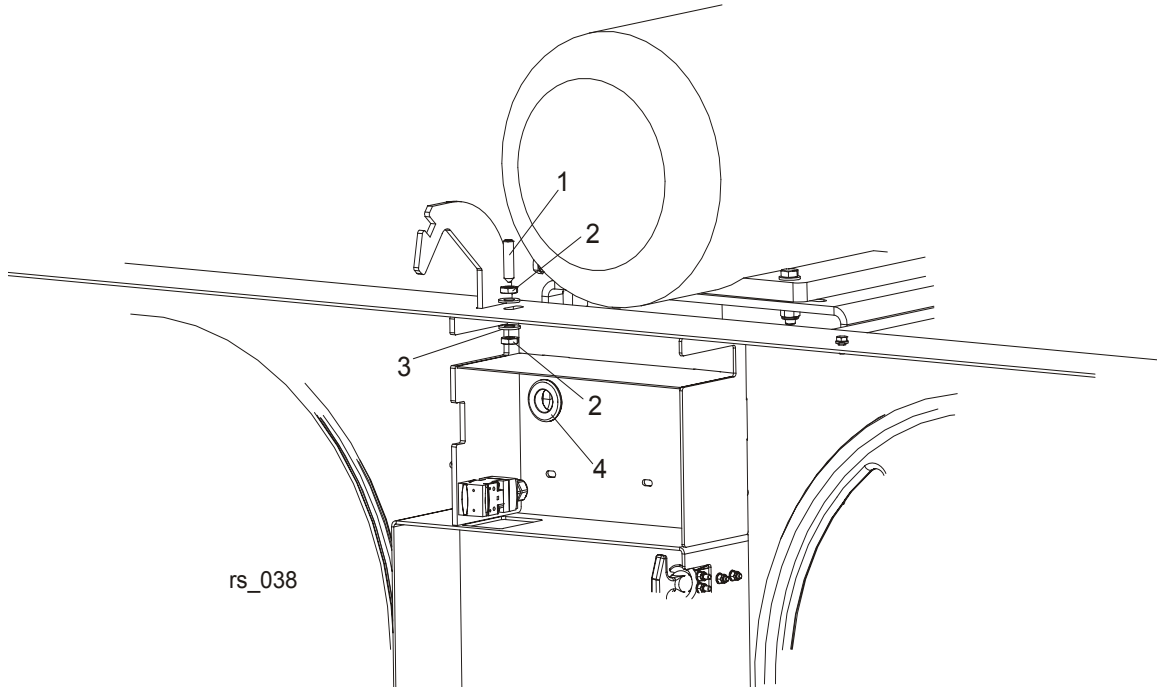

REF	DESCRIPTION (◆ Indicates Parts Available in Assemblies Only)	PART #	QTY.	
1	SCREW, M10X40-45H HEX SOCKET SET CONE POINT ZINC	F81003-61	1	
2	NUT, M10-8-B HEX ZINC	F81033-6	2	
3	WASHER, 10.5 FLAT ZINC	F81055-1	2	
4	GROMMET, 22mm DIA.	087400	1	

6 Replacement Parts

Water Lube Assembly

6.9 Water Lube Assembly

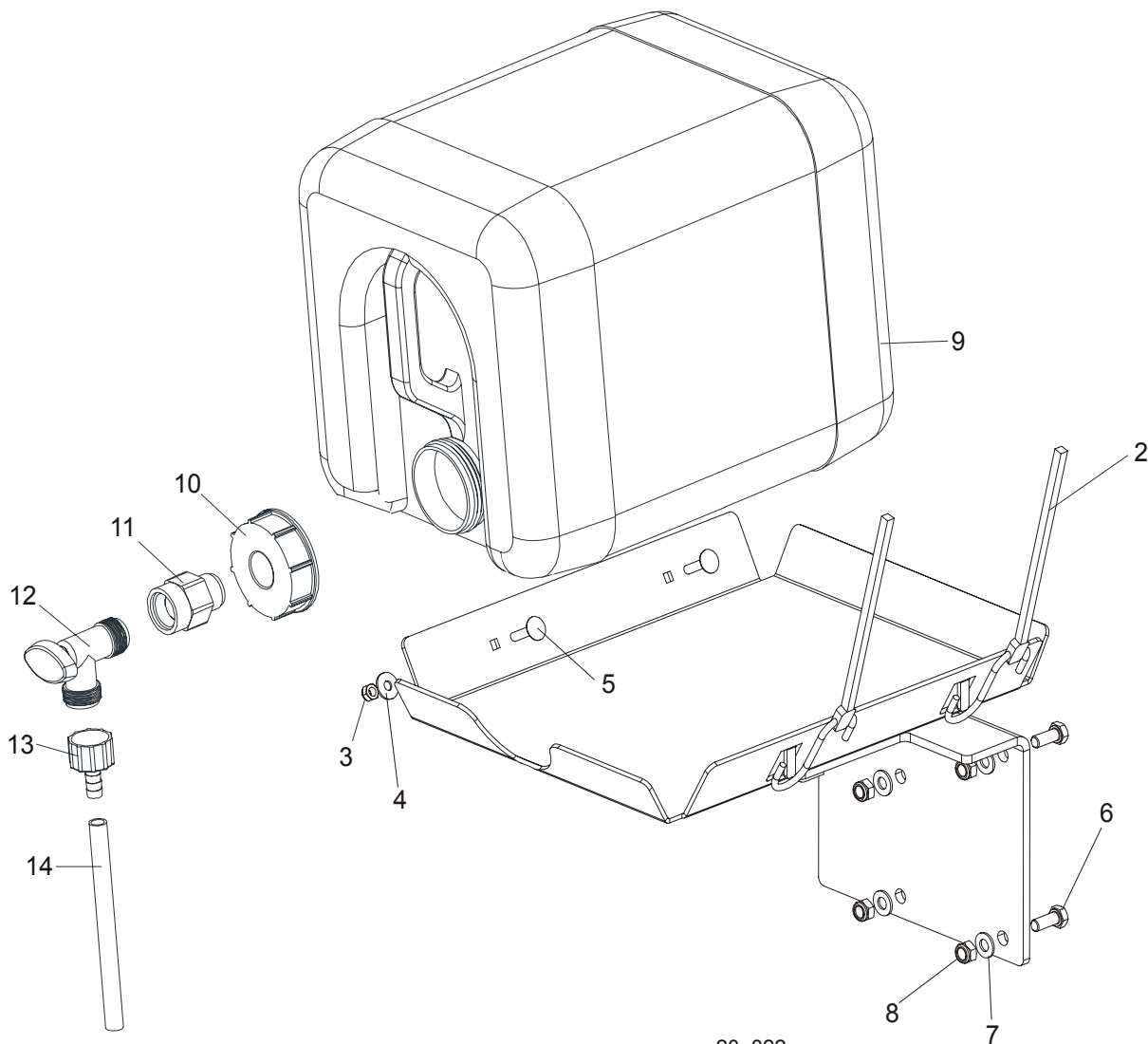

20_022

REF	DESCRIPTION (◆ Indicates Parts Available In Assemblies Only)	PART #	QTY.
	WATER LUBE ASSEMBLY	091036	1
1	Tray, Water Lube Bottle	091033-1	1
2	Strap, 20" Rubber w/Hook	P11668	2
3	Nut, M6-8-B Hex Nylon Lock Zinc	F81031-2	2
4	Washer, 6.5 Special Flat Zinc	F81053-11	2
5	Bolt, M6x25-8.8 Carriage Head Zinc	F81001-20	2
6	Bolt, M8x20-5.8 Hex Head Full Thread Zinc	F81002-1	2
7	Washer, 8.4 Flat Zinc	F81054-1	2
8	Nut, M8-8-B Hex Nylon Zinc Lock	F81032-2	2
	Water Lube Bottle Assembly	014642	1
9	Bottle, 19l Water Lube	014637	1

10	Cap, Water Lube Bottle	014773	1	
	Cap, 70 mm Buttress Thread Water Lube Bottle	014754	1	
11	Fitting, 3/4FPT x 3/4MPT	014636	1	
12	Fitting, Water Lube Shutoff Valve	014100	1	
13	Reducer, 5/8" NPT to 3/8" Hose Barb	014113	1	
14	Tubing, 3/8" I.D. Water Lube	R01885	2.1 m	

6 Replacement Parts

Saw Head Safety Decals

6.10 Saw Head Safety Decals

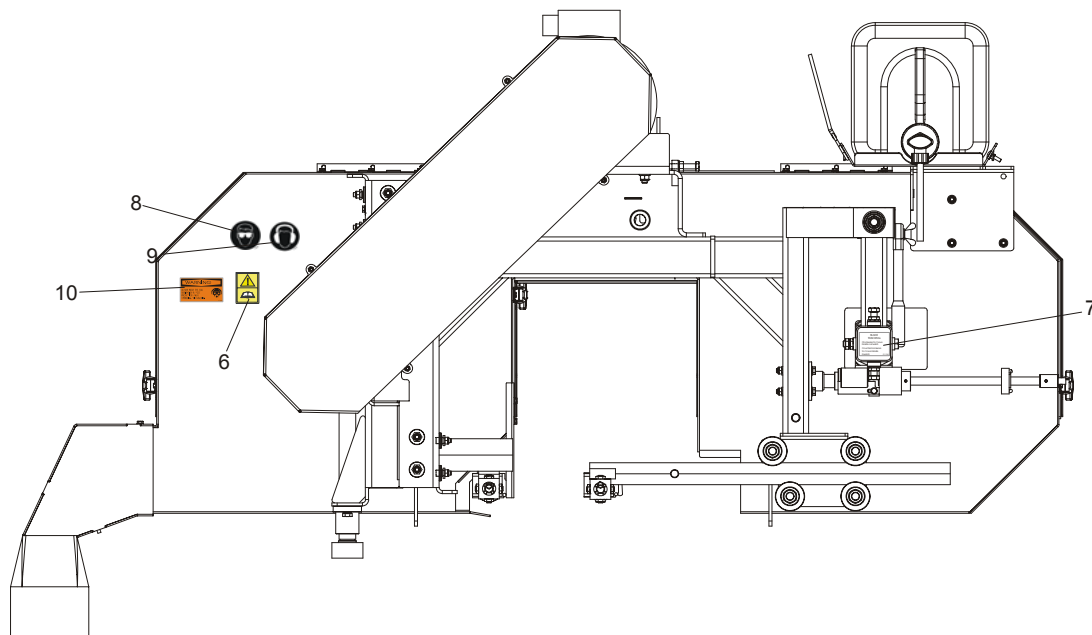
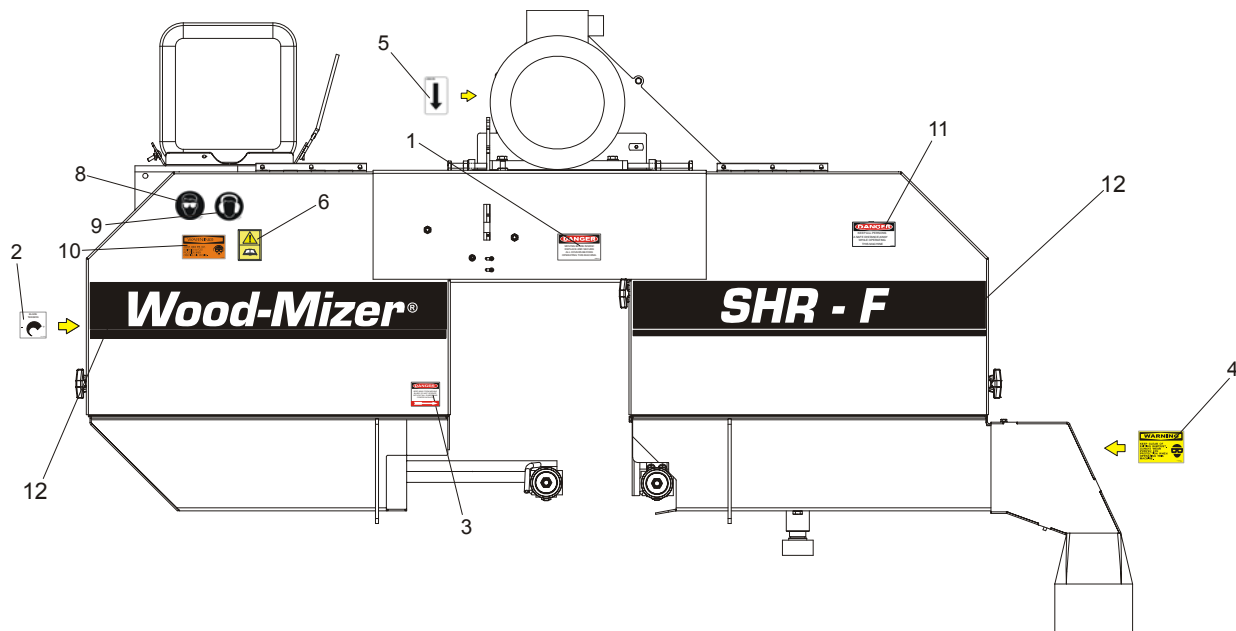

REF	DESCRIPTION (◆ Indicates Parts Available in Assemblies Only)	PART #	QTY.
	DECAL KIT, RESAW - COMPLETE	094944	1
1	DECAL, BLADE COVER DANGER	S20039	1
2	DECAL, TENSION SCREW	P11790	1
3	DECAL, BLADE DANGER ARROW	S11752	1
4	DECAL, SAWDUST CHUTE WARNING	P11754	1
5	DECAL, MOTOR DIRECTION	S20097	1

6	DECAL, "READ THE MANUAL"	091629	2	
7	DECAL, BLADE ALIGNMENT	P11789	1	
8	DECAL, EYE WARNING	S12004	2	
9	DECAL, EAR WARNING	S12005	2	
10	DECAL, EYE/EAR PROTECTION WARNING	S11753	2	
11	DECAL, KEEP AWAY DANGER	S09851	1	
12	DECAL KIT, MACHINE NAME (SHR-F)	094945	1	
	DECAL KIT, MACHINE NAME (SHR-T)	095014	1	

6 Replacement Parts *Blade Housing Cover*

6.11 Blade Housing Cover

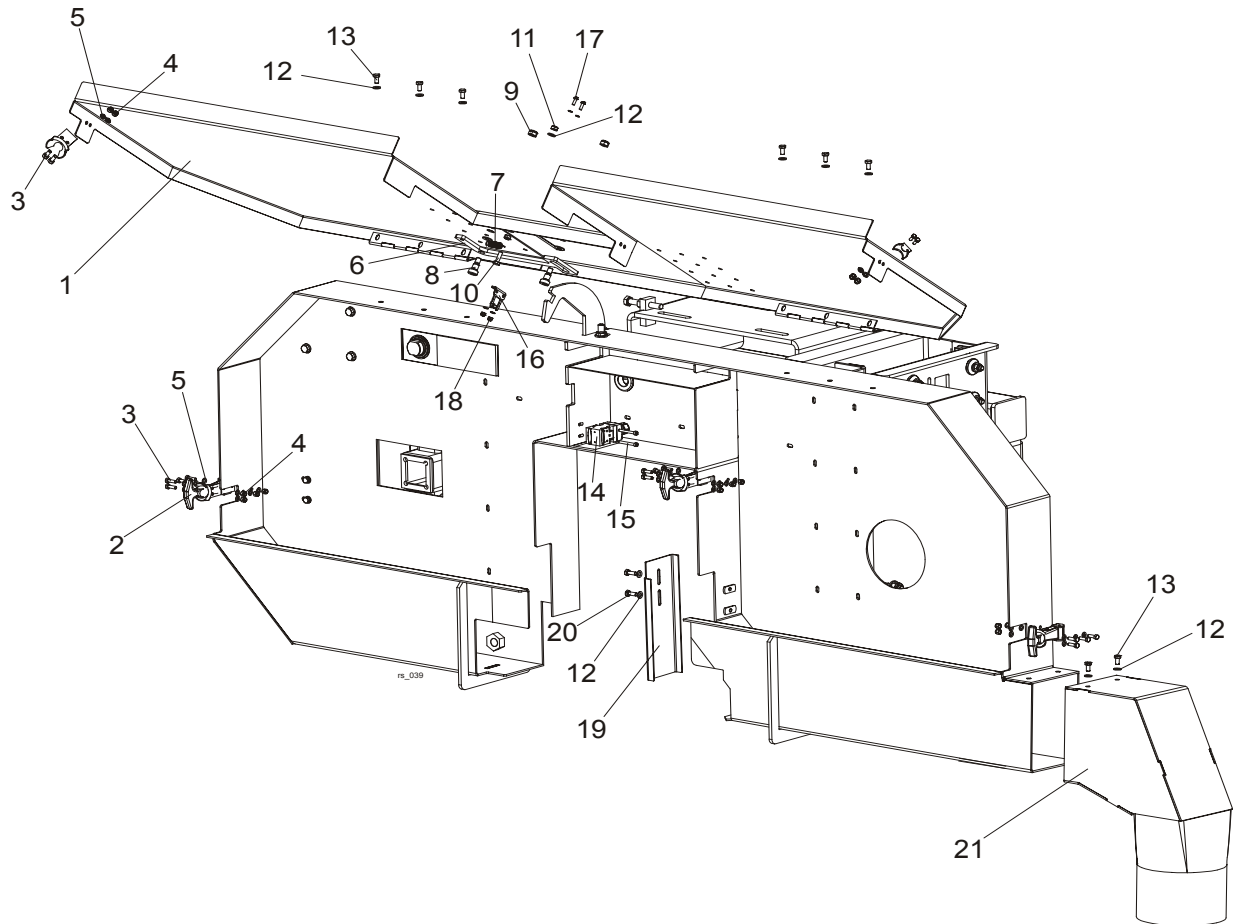

REF	DESCRIPTION (◆ Indicates Parts Available In Assemblies Only)	PART #	QTY.
1	COVER WELDMENT, RESAW BLADE HOUSING	093251-1	1
2	LATCH, FLEXIBLE DRAW	014829	3
3	BOLT, M5 X 16-5.8 HEX HEAD FULL THREAD ZINC	F81000-51	12
4	NUT, M5-8 DIN 985 ZINC	F81030-2	12
5	WASHER, 5.3 FLAT ZINC	F81052-1	24
6	PAWL, LOCKING PAINTED	090643-1	1
7	SPRING, 1.6 X 12 X 38 EXTENSION	092208	1
8	BOLT, 10/M8X12-12.9 ISO-7379 SHOULDER	F81003-62	2
9	NUT, M8-8-B HEX NYLON ZINC LOCK	F81032-2	2
10	BOLT, M6X20-8.8 HEX HEAD FULL THREAD ZINC	F81001-2	1
11	NUT, M6-8-B HEX NYLON ZINC LOCK	F81031-2	2
12	WASHER, 6.4 FLAT ZINC	F81053-1	12
13	BOLT, M6X12-8.8 HEX HEAD FULL THREAD ZINC	F81001-7	8
14	SWITCH, AZ17-11ZRK SAFETY	094232	1
15	SCREW, M4X35-8.8 HEX SOCKET HEAD CAP ZINC	F81011-34	2
16	KEY, AZ17/170-B5 SAFETY SWITCH	094422	1
17	SCREW, M4X12-5.8-B CROSS RECESSED PAN HEAD ZINC	F81011-43	2

Replacement Parts
Blade Housing Cover

6

18	NUT, M4-B HEX NYLON ZINC LOCK	F81029-1	2	
19	GUARD, BLADE GUIDE ROLLER PAINTED	094737-1	1	
20	BOLT, M6X16 8.8 HEX HEAD FULL THREAD ZINC	F81001-15	2	
21	CHUTE, RESAW SAWDUST	094059-1	1	

6 Replacement Parts

Control Panel

6.12 Control Panel

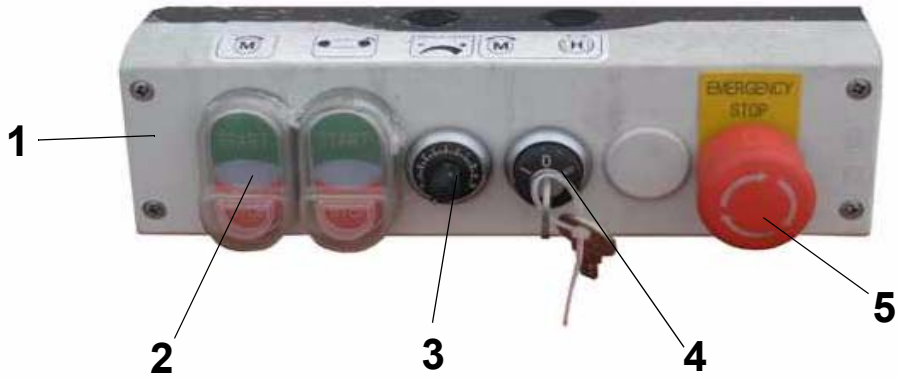

REF	DESCRIPTION (◆ Indicates Parts Available in Assemblies Only)	PART #	QTY.	
1	BOX, M22-I6 (216540) CONTROL	093750	1	
2	OPERATOR, M22-DDI-GR-GB1/GB0 SWITCH	094997	2	
	Contact Element, M22-KC10	094314	1	
	Contact Element, M22-KC01	094998	1	
	LED Element, M22-LEDC-W	094999	1	
3	POTENTIOMETER, M22-R1K (229489)	093749	1	
4	OPERATOR, M22-WRS3 KEY SWITCH	095001	1	
5	OPERATOR, M22-PV E-STOP	095002	1	
	Contact Element, M22-KC01	094998	2	
	Legend Plate, E-Stop	094332	1	

6.13 Saw Head Height Adjustment Screw

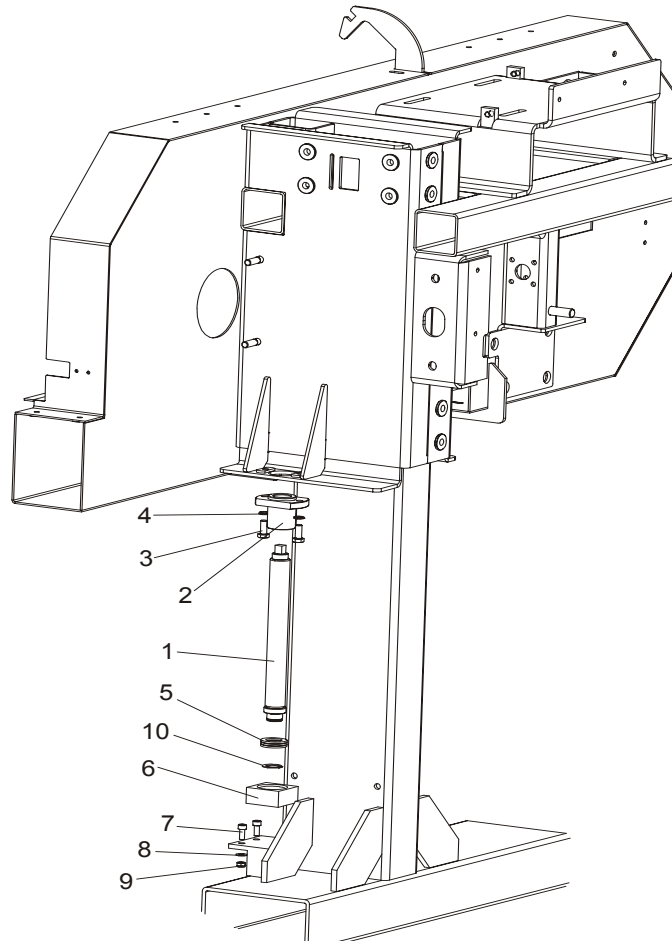

REF	DESCRIPTION (◆ Indicates Parts Available In Assemblies Only)	PART #	QTY.	
1	SCREW, ACME ZINC-PLATED (SAW HEAD HEIGHT ADJUSTMENT)	093263-1	1	
2	NUT, ACME SCREW FLANGED ZINC-PLATED	093264-1	1	
3	BOLT, M10X25 8.8 HEX HEAD FULL THREAD	F81003-31	2	
4	WASHER, 10.2 SPLIT LOCK ZINC	F81055-2	2	
5	BEARING, 51105 THRUST	088033	1	
6	BLOCK, ACME SCREW REST ZINC-PLATED	093265-1	1	
7	SCREW, M8X20-8.8 HEX SOCKET HEAD CAP ZINC	F81002-30	2	
8	WASHER, 8.4 FLAT ZINC	F81054-1	2	
9	NUT, M8-8-B HEX NYLON ZINC LOCK	F81032-2	2	
10	RING, 25Z OUTSIDE RETAINING	F81090-22	1	

6 Replacement Parts

Mast Tilt Adjustment Screw

6.14 Mast Tilt Adjustment Screw

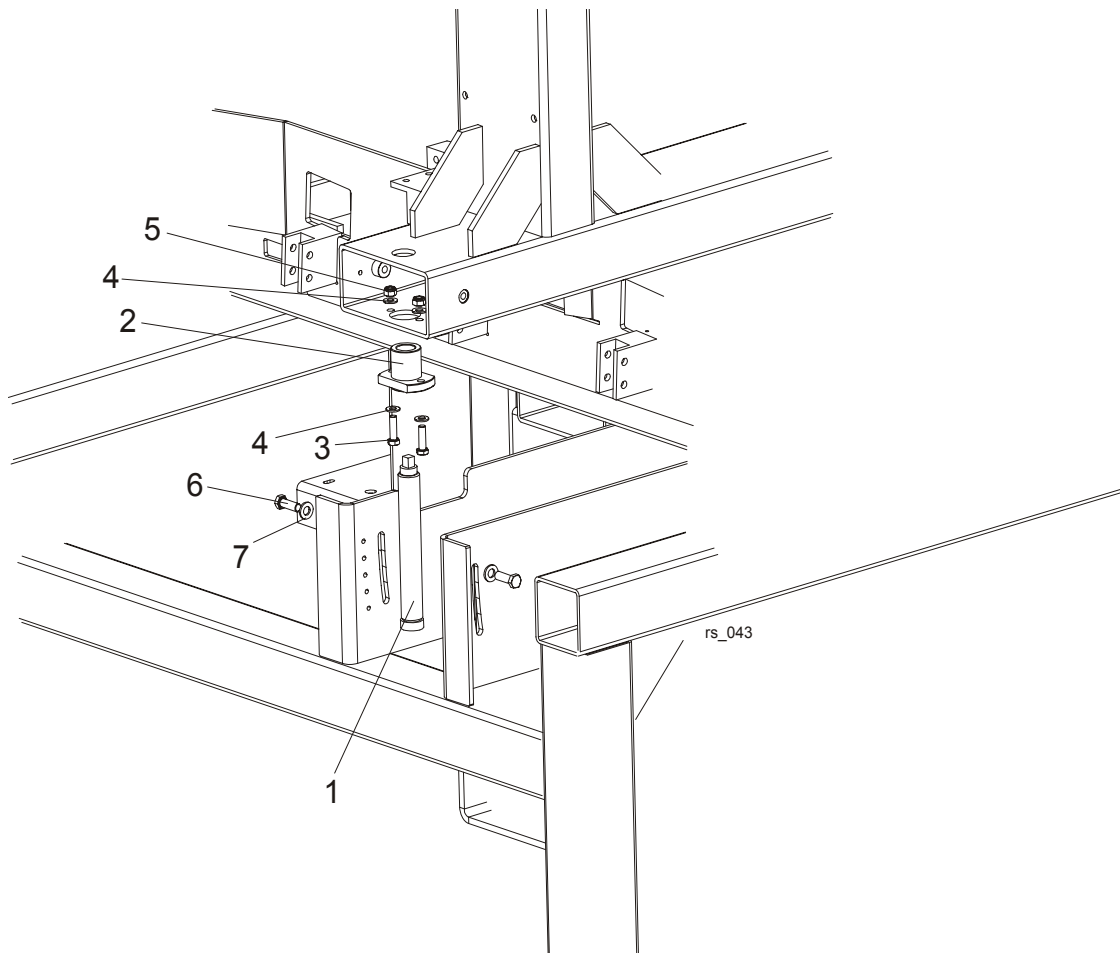

REF	DESCRIPTION (◆ Indicates Parts Available In Assemblies Only)	PART #	QTY.	
1	ACME SCREW, MAST TILT ADJUSTMENT	093509-1	1	
2	NUT, ACME SCREW FLANGED ZINC-PLATED	093264-1	1	
3	BOLT, M10X35-8.8 HEX HEAD FULL THREAD ZINC	F81003-17	2	
4	WASHER, 10.5 FLAT ZINC	F81055-1	4	
5	NUT, M10-8-B HEX NYLON ZINC LOCK	F81033-1	2	
6	BOLT, M12X35-8.8 HEX HEAD FULL THREAD ZINC	F81004-24	2	
7	WASHER, 13 FLAT ZINC	F81056-1	2	

6.15 Vertical Mast Slide Pads

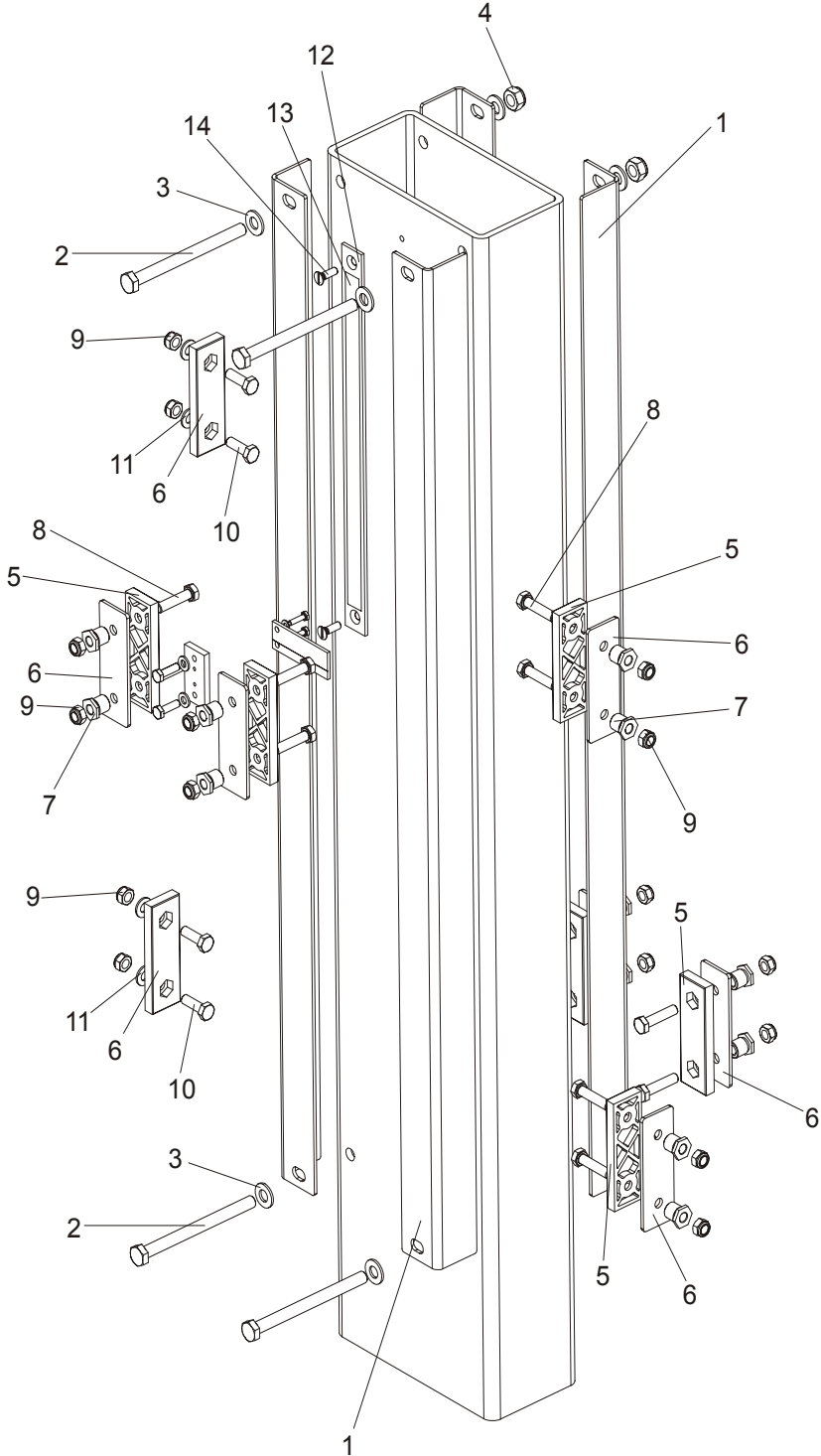

REF	DESCRIPTION (◆ Indicates Parts Available In Assemblies Only)	PART #	QTY.	
1	ANGLE, VERTICAL MAST TUBE	093890	4	
2	BOLT, M10X125-8.8 HEX HEAD ZINC	F81003-18	4	
3	WASHER, 10.5 FLAT ZINC	F81055-1	8	

6

Replacement Parts*Vertical Mast Slide Pads*

4	NUT, M10-8-B HEX NYLON ZINC LOCK	F81033-1	4	
5	PADS, DELRIN UP/DOWN SLIDE	M04096	8	
6	PLATE, SLIDE PAD MOUNTING PAINTED	093246-1	6	
7	NUT, SLIDE PAD ADJUSTMENT ZINC-PLATED	086683	12	
8	BOLT, M8X35-8.8 HEX HEAD FULL THREAD ZINC	F81002-13	12	
9	NUT, M8-8-B HEX NYLON ZINC LOCK	F81032-2	16	
10	BOLT, M8X25-8.8-B HEX HEAD FULL THREAD ZINC	F81002-5	4	
11	WASHER, 8.4 FLAT ZINC	F81054-1	4	
	SCALE ASSEMBLY, RESAW PL BLADE HEIGHT	094820	1	
12	Bar, Resaw Blade Height Scale	094818	1	
13	Scale, 0-30 cm. Resaw Metric	094819	1	
14	SCREW, M6X20-4.8-B SLOTTED COUNTERSUNK HEAD ZINC	F81001-31	2	

6.16 Motor Assembly

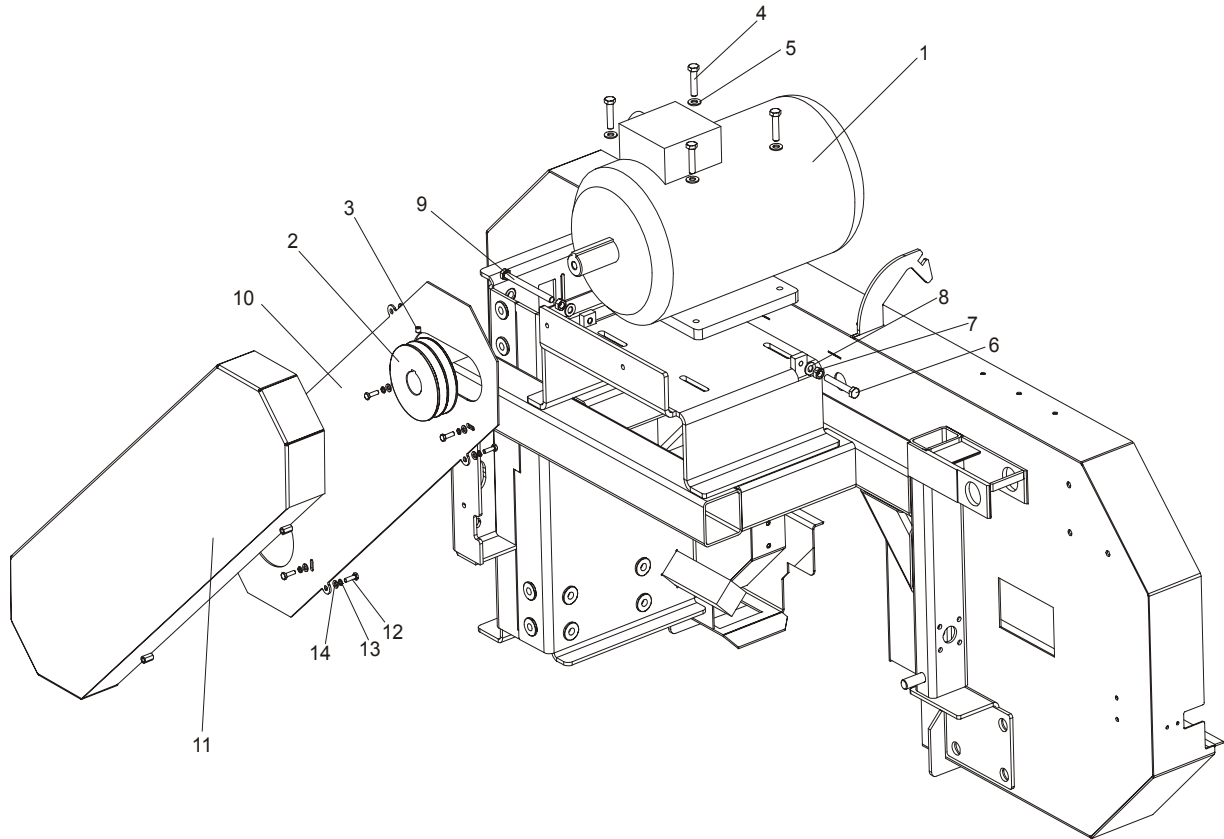

REF	DESCRIPTION (◆ Indicates Parts Available in Assemblies Only)	PART #	QTY.	
1	MOTOR, 7.5kW Sg132M-4B - HM	094996	1	
	MOTOR, 11kW Sg132M-4PC-HM	093219	1	
2	PULLEY, SPB 112X1 1610/38 (E11) W/BUSHING	095077	1	
	PULLEY, E15 2-GROOVE	091560	1	
3	SCREW, M8X8-33H HEX SOCKET SET FLAT POINT ZINC	F81014-1	1	
4	BOLT, M10X45-8.8 HEX HEAD FULL THREAD ZINC	F81003-3	4	
5	WASHER, 10.5 FLAT ZINC	F81055-1	4	
6	BOLT, M10X70-8.8 HEX HEAD FULL THREAD ZINC	F81003-20	1	
7	NUT, M10-8-B HEX ZINC	F81033-3	2	
8	WASHER, 10.5 FLAT ZINC	F81055-1	2	
9	BOLT, M10X120 8.8 HEX HEAD FULL THREAD ZINC	F81003-47	1	
10	COVER, DRIVE BELT GUARD PAINTED	093259-1	1	
11	GUARD WELDMENT, RESAW DRIVE BELT PAINTED	093262-1	1	
12	BOLT, M6X20-8.8 HEX HEAD FULL THREAD ZINC	F81001-2	8	
13	WASHER, Z 6.1 SPLIT LOCK ZINC	F81053-3	8	
14	WASHER, 6.4 FLAT ZINC	F81053-1	8	
	V-BELT, B72 (1829li) Good-Year (E11)	095079	1	
	BELT, 2BX70 11kW (E15) MOTOR DRIVE	P04857-2	1	

6 Replacement Parts

Feed Track Assembly (SHR-F)

6.17 Feed Track Assembly (SHR-F)

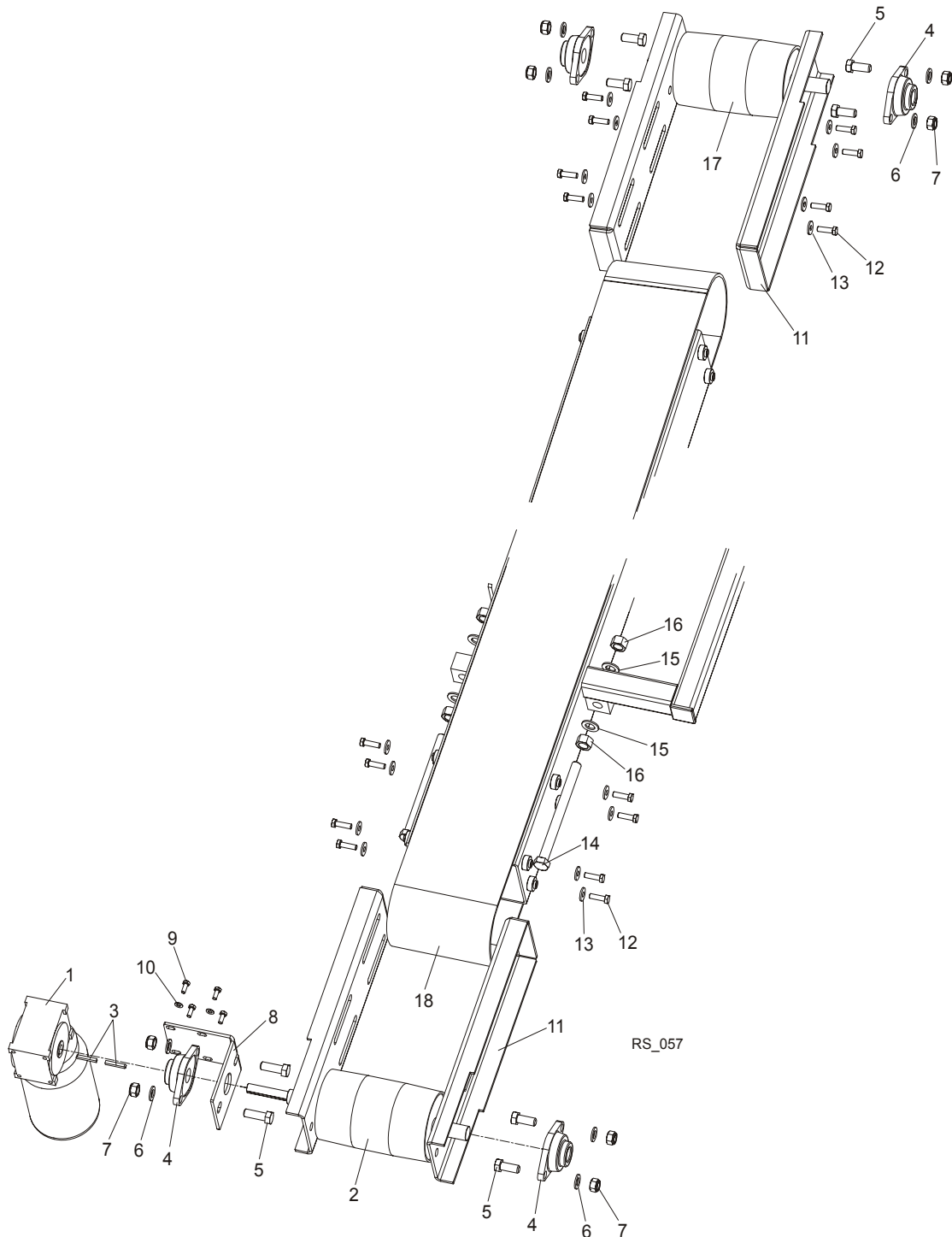

REF	DESCRIPTION (◆ Indicates Parts Available In Assemblies Only)	PART #	QTY.
1	MOTOR & GEAR BOX, MRA-04/15.5/D4/STN 0.37KW 900RPM	094897	1
2	PULLEY, SHR-F DRIVE SIDE PAINTED	094891-1	1
3	KEY, AB 6X6X45 PARALLEL	089229	2

Replacement Parts

Feed Track Assembly (SHR-F)

6

4	BEARING, UCFL 206 CX BALL	090851	4	
5	BOLT, M16X50-8.8 HEX HEAD FULL THREAD ZINC	F81006-7	8	
6	WASHER, 17 FLAT ZINC	F81058-1	8	
7	NUT, M16-8 HEX NYLON ZINC LOCK	F81036-2	8	
8	BRACKET, SHR-F GEAR BOX MOUNT PAINTED	094898-1	1	
9	BOLT, M8X20-5.8 HEX HEAD FULL THREAD ZINC	F81002-1	4	
10	WASHER, 8.4 FLAT ZINC	F81054-1	4	
11	BRACKET, SHR-F PULLEY MOUNT PAINTED	094889-1	4	
12	BOLT, M10X35-8.8 HEX HEAD FULL THREAD ZINC	F81003-17	16	
13	WASHER, 10.5 SPECIAL FLAT ZINC	F81055-6	16	
14	BOLT, M20X240-8.8 HEX HEAD FULL THREAD ZINC	F81007-1	2	
15	WASHER, 21 FLAT ZINC	F81059-2	4	
16	NUT, M20-8 HEX ZINC	F81037-1	4	
17	PULLEY, SHR-F IDLE SIDE PAINTED	094892-1	1	
18	TAPE, A33 QF L=8450 B=230	094911	1	
	COVERING FOR PULLEYS	R00100	3.00 m	
	RIVET, P AL/FE 4X10 TUBULAR W/CORE	F81021-11	2	

6.18 Hold-Down Roller Assembly, SHR-F

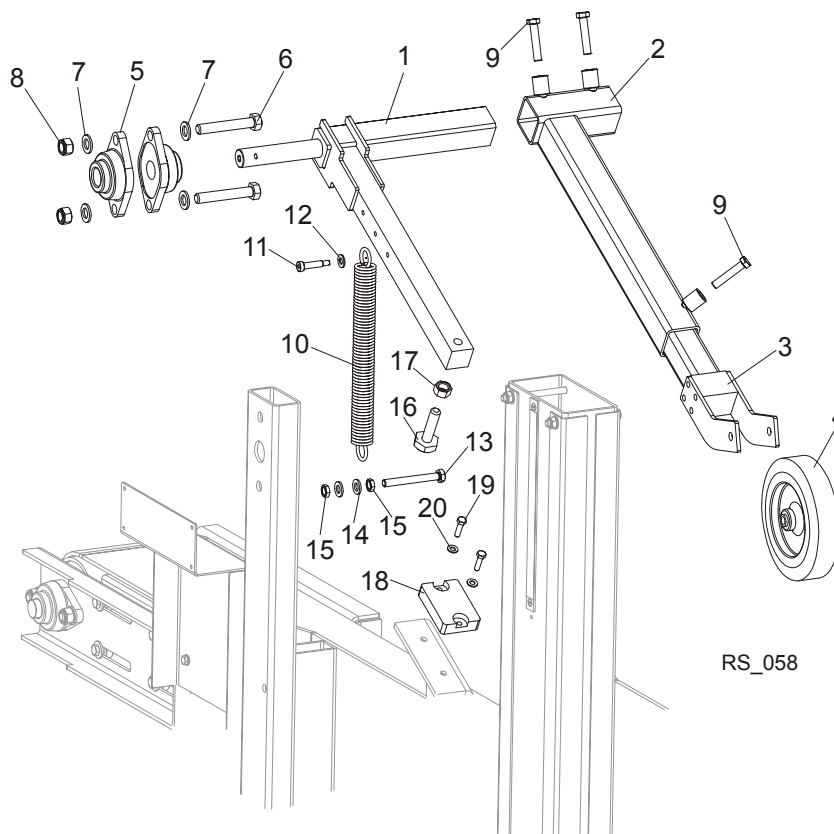

REF	DESCRIPTION (◆ Indicates Parts Available in Assemblies Only)	PART #	QTY.
1	ARM, SHR-F HOLD-DOWN ROLLER PIVOT	094965-1	1
2	ARM, SHR-F HOLD-DOWN ROLLER OUTSIDE	094960-1	1
3	ARM WELDMENT, SHR-F HOLD-DOWN ROLLER INSIDE PAINTED	094913-1	1
4	WHEEL, FI 200 MG 61N (SHR-F) W/BUSHING	094465	1
5	BEARING, UCFL 206 CX BALL	090851	2
6	BOLT, M16X100-8.8 HEX HEAD FULL THREAD ZINC	F81006-2	2
7	WASHER, 17 FLAT ZINC	F81058-1	4
8	NUT, M16-8 HEX NYLON ZINC LOCK	F81036-2	2
9	BOLT, M12X60-8.8 HEX HEAD FULL THREAD ZINC	F81004-51	3
10	SPRING, FI 4.5X FI 35X303	091863	1
11	BOLT, 10/M8X35 12.9 ISO7379 SHOULDER	F81003-63	1
12	WASHER, 10.5 FLAT ZINC	F81055-1	1
13	BOLT, M12X1.25X100-8.8 HEX HEAD FULL THREAD ZINC	F81004-41	1
14	WASHER, 13 FLAT ZINC	F81056-1	2
15	NUT, M12X1.25 8.8 HEX THIN ZINC	F81034-5	2
16	BOLT, M16 BED RAIL ADJUSTMENT	086809	1
17	NUT, M16-5-B HEX	F81036-5	1
18	BUMPER, GRENE 70 3201 0010. SHR RUBBER	094969	1
19	BOLT, M8X30-5.8 HEX HEAD FULL THREAD ZINC	F81002-2	2
20	WASHER, 8.4 FLAT ZINC	F81054-1	2

6.19 Guide Fence Assembly, SHR-F

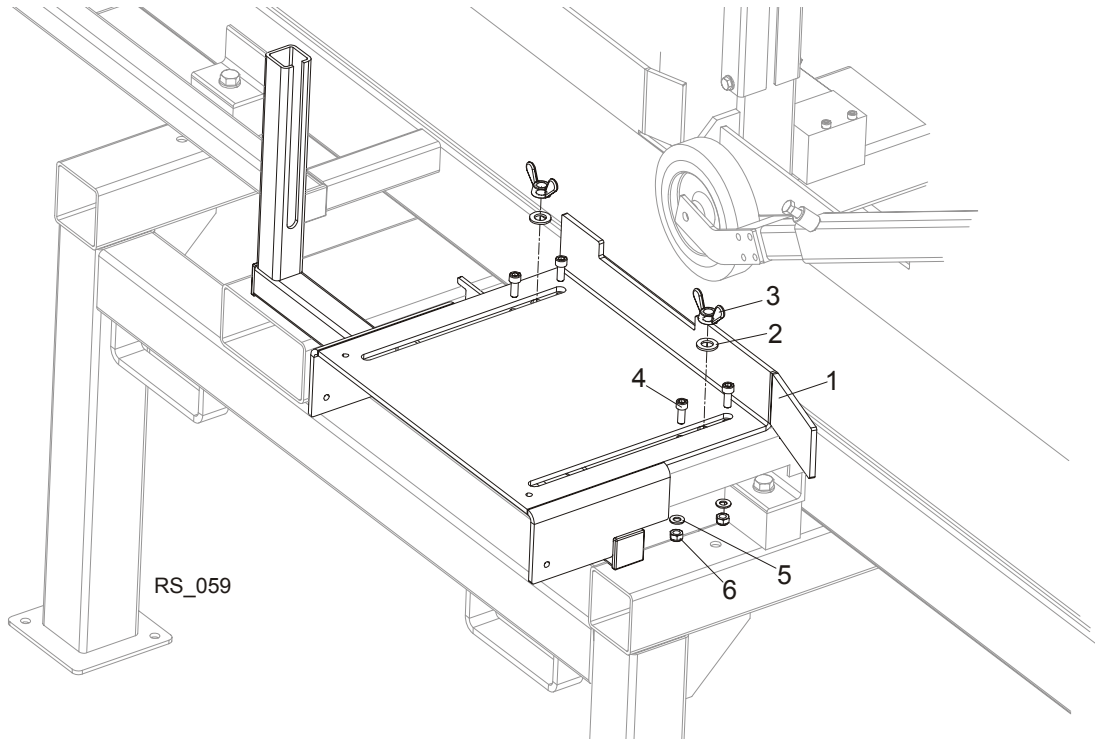

REF	DESCRIPTION (◆ Indicates Parts Available in Assemblies Only)	PART #	QTY.
1	FENCE WELDMENT, SHR-F LOG GUIDE PAINTED	094901-1	1
2	WASHER, 17 FLAT ZINC	F81058-1	2
3	NUT, M16 WING ZINC	F81036-3	2
4	SCREW, M10X25 8.8 HEX SOCKET HEAD CAP ZINC	F81003-32	4
5	WASHER, 10.5 FLAT ZINC	F81055-1	4
6	NUT, M10-8-B HEX NYLON ZINC LOCK	F81033-1	4

6

Replacement Parts Infeed, Outfeed & Return Tables

6.20 Infeed, Outfeed & Return Tables

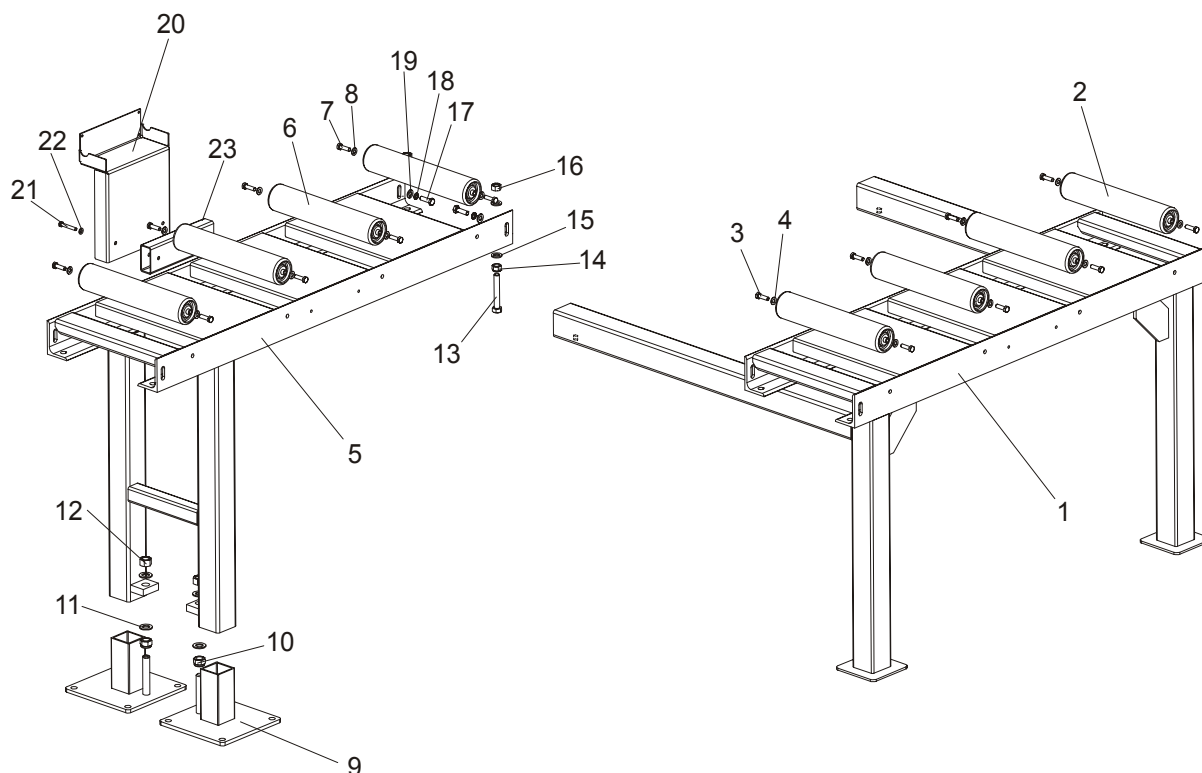

REF	DESCRIPTION (◆ Indicates Parts Available in Assemblies Only)	PART #	QTY.	
	TABLE ASSEMBLY, RESAW RETURN	094721	1	
1	Table Weldment, Return Painted	094515-1	1	
2	Roller, 76 Dia. x 400 w/Internal Thread Table Painted	093787-1	4	
3	Bolt, M10x35-8.8 Hex Head Full Thread Zinc	F81003-17	8	
4	Washer, 10.5 Flat Zinc	F81055-1	8	
	TABLE ASSEMBLY, RESAW FEED (SHR-T)	093790	2	
5	Table Weldment, Feed Painted	094831-1	1	
6	Roller, 76 Dia. x 400 w/Internal Thread Table Painted	093787	4	
7	Bolt, M10x35-8.8 Hex Head Full Thread Zinc	F81003-17	8	
8	Washer, 10.5 Flat Zinc	F81055-1	8	
9	Plate Weldment, Leg Foot Painted	089283-1	2	
10	Nut, M20-8-A Hex Nylon Zinc Lock	F81037-2	2	
11	Washer, 21 Flat Zinc	F81059-2	4	
12	Nut, M20-8 Hex Zinc	F81037-1	2	
13	Bolt, M16x100-8.8 Hex Head Full Thread Zinc	F81006-2	2	
14	Nut, M16-8 Hex Nylon Zinc Lock	F81036-2	2	
15	Washer, 17 Flat Zinc	F81058-1	4	
16	Nut, M16-5.8 Hex Zinc	F81036-1	2	
17	Bolt, M12x40-8.8 Hex Head Full Thread Zinc	F81004-4	2	
18	Washer, Z12.2 Split Lock Zinc	F81056-2	2	
19	Washer, 13 Flat Zinc	F81056-1	2	

20	BRACKET, RESAW CONTROL BOX MOUNT PAINTED	094075-1	1	
21	BOLT, M8X55 8.8 HEX HEAD ZINC	F81002-8	2	
22	WASHER, 8.4 FLAT ZINC	F81054-1	2	
23	TUBE, RESAW CONTROL BOX SPACER PAINTED	094738-1	1	

SECTION 7 DC ELECTROMAGNETIC BRAKE

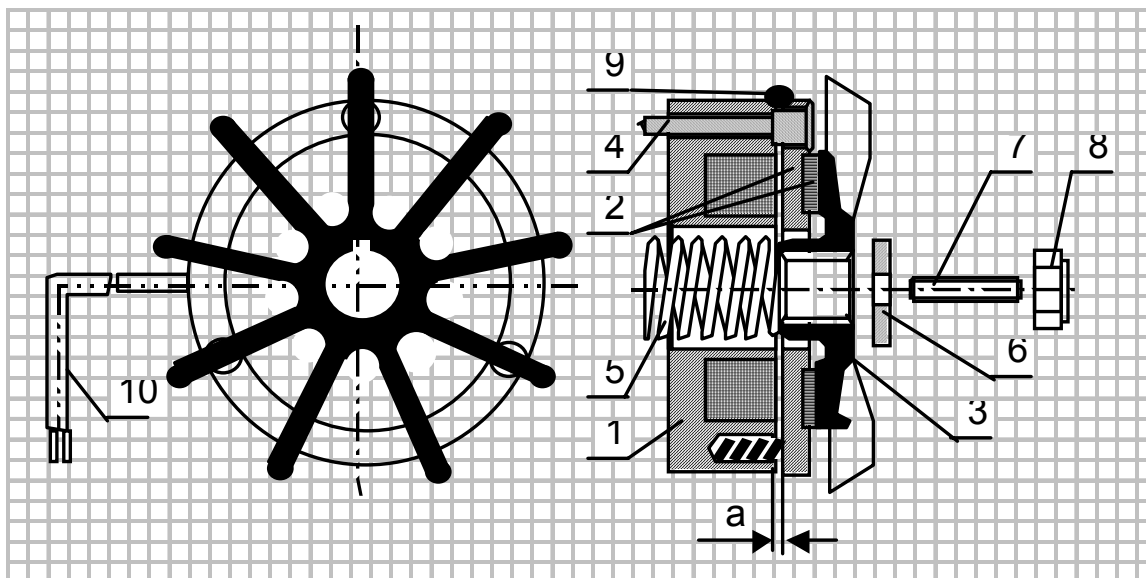

- 1 - Electromagnet,
- 2 - Armature complete with brake linings
- 3 - Fan,
- 4 - Retaining bolt
- 5 - Central spring,
- 6 - Special washer,
- 7 - Set screw,
- 8 - Self-locking nut,
- 9 - Sealing ring,
- 10 - Output cable.

7.1 Design and principle of operation

The DC electromagnetic brake type H consists of 3 main subassemblies:

- electromagnet (1),
- armature complete (2)
- cast iron fan (3).

Electromagnet (1) energised: The DC voltage from the motor applied via the rectifying circuit causes the attraction of the armature (2) releasing the brake and thus the fan (3) is free to rotate.

Electromagnet (1) de-energised: The electromagnet stops to attract the armature (2) and spring presses the armature with brake linings (2) against the fan and the brake is thus applied.

7.2 Service

During normal operation and at the routine inspections verify the air gap and check if all screws are tight. In case when any symptoms of inefficient braking are observed, then use the self-locking nut (8) to re-adjust the air gap to the value corresponding to Table 1.

Such readjustment may be repeated until the brake linings are completely worn out. When this will occur, a complete armature with brake linings (2) must be replaced.

If the air gap of the brake is correctly adjusted and despite of it the brake does not operate properly (the brake fails to release), it may be caused by:

- the electromagnet (1): burned coil or defected output cable (10),
- rectifying circuit (installed in the electric motor terminal box).

The above mentioned subassemblies should be checked and defected part replaced.

Table 1:

TYPE	H-63	H-71	H-80	H-90	H-100	H-112	H-132	H-160
Nominal Gap „a”	0.2 ±0,05	0.2 ±0,05	0.2 ±0,05	0.2 ±0,05	0.2 ±0,1	0.2 ±0,1	0.2 ±0,1	0.2 ±0,1